

THIS DRAWING IS UNPUBLISHED. RELEASED FOR PUBLICATION
 © COPYRIGHT - TE Connectivity Ltd. ALL RIGHTS RESERVED.

P	LTR	DESCRIPTION	DATE	DWN	APVD
	B	TRANSFER ECOC	07/03	-	CA
	B1	REVISED PER ECO-18-002105	27FEB2018	RS	DR

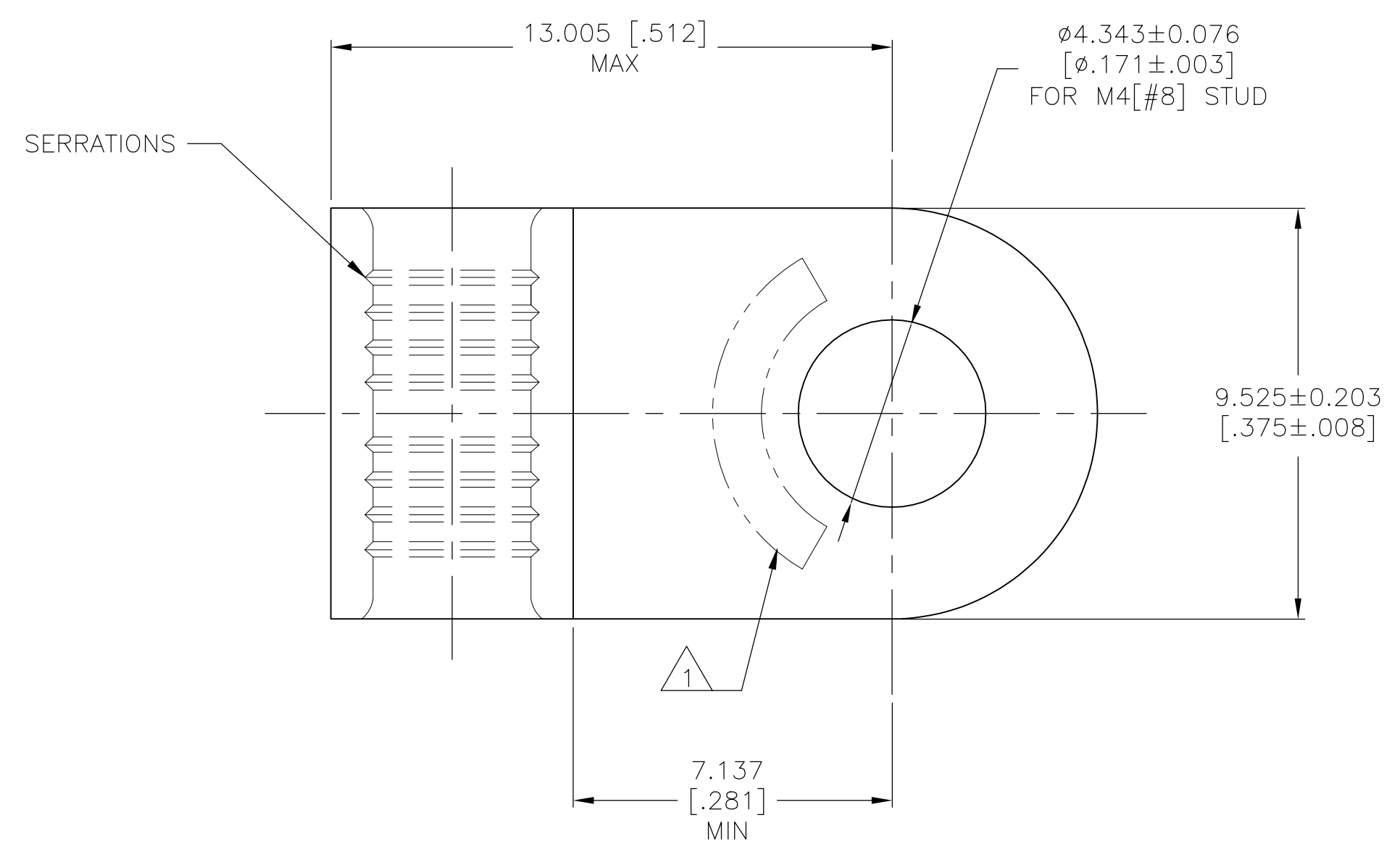

AMP
 WIRE RANGE
 12-10 AWG
 SOLID OR STRANDED

- 1 STAMP AMP 12-10* APPROX AS SHOWN
- 2 MATERIAL: COPPER PER ASTM B152, ANNEALED
- 3 FINISH: NICKEL PLATE 0.00762[.000300] MIN
EXT THK PER SAE AMS QQ-N-290

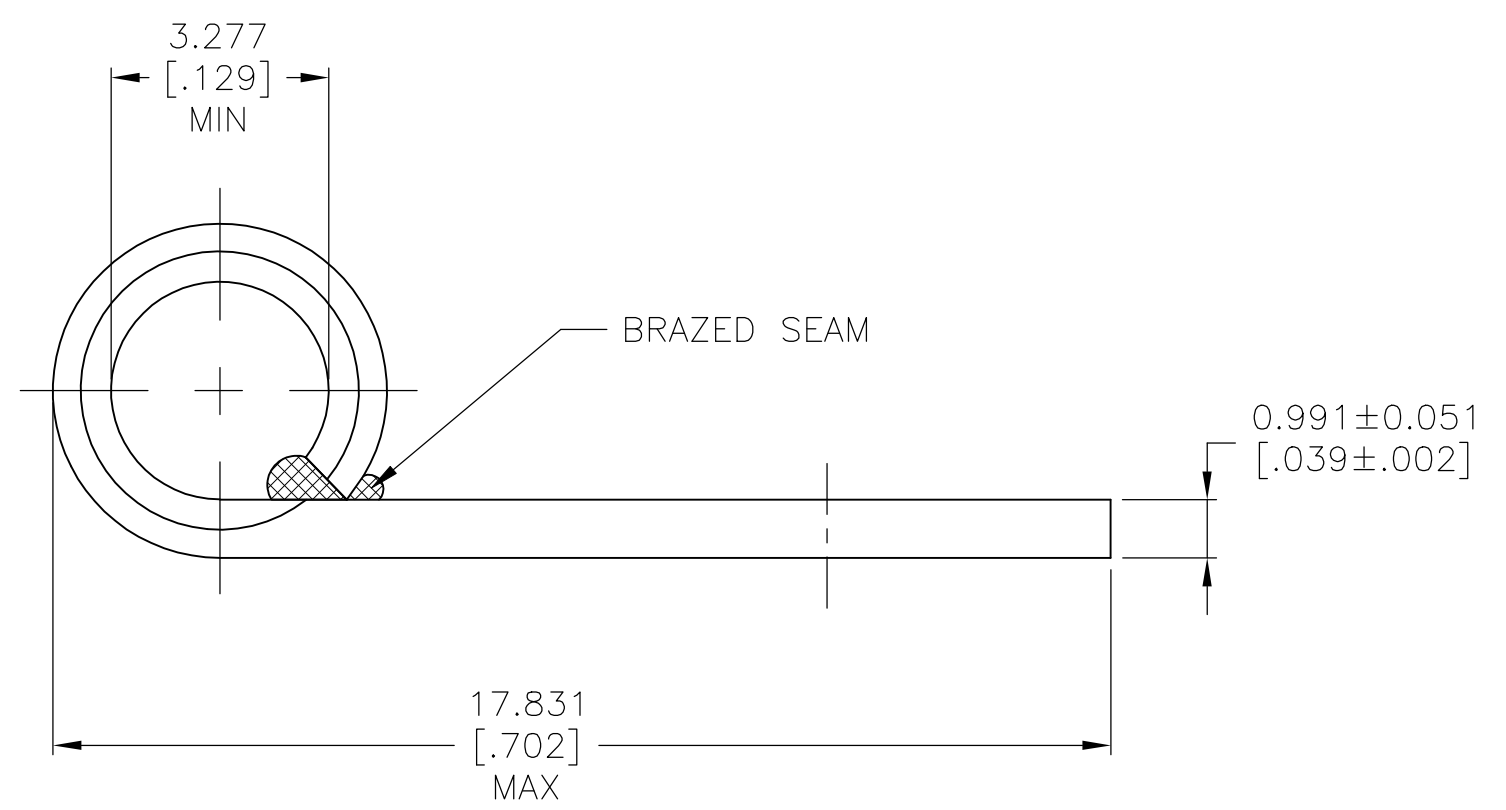

PRELIMINARY	5000	BULK/BAG	132005-2
	500	LOOSE PIECE	132005-1
QUANTITY		PACKAGING TYPE	PART NO

AMP INCORPORATED
 CUSTOMER SERVICE SYSTEMS

FOR ADDITIONAL PRODUCT INFORMATION OR COPIES OF DRAWINGS AND TECHNICAL DOCUMENTS	PRODUCT INFORMATION CENTER 1-800-522-6752	MAX RECOMMENDED OPERATING TEMPERATURE: 343°C [649°F] MAX
FOR APPLICATION TOOLING INFORMATION	TOOLING ASSISTANCE CENTER 1-800-722-1111	VOLTAGE RATING: NOT APPLICABLE
FOR ORDER ENTRY	1-800-526-5142	WIRE CROSS SECTIONAL AREA RANGE, 2.62-6.64mm²[5,180-13,100] CIR MILS SOLID OR STRANDED

THIS DRAWING IS A CONTROLLED DOCUMENT.

DIMENSIONS: mm [INCHES]	TOLERANCES UNLESS OTHERWISE SPECIFIED:
0 PLC ± -	1 PLC ± -
2 PLC ± -	3 PLC ± 0.127[.005]
4 PLC ± -	ANGLES ± 5°

MATERIAL: 2 FINISH: 3

DWN: RAVI S 27FEB2018
 CHK: ROHDE DANIEL F 27FEB2018
 APVD: ROHDE DANIEL F 27FEB2018

TE Connectivity Ltd.
 NAME: TERMINAL, STRATO-THERM, HR, FLAG
 12-10 AWG

SIZE: A2 CAGE CODE: 00779 DRAWING NO: 132005 RESTRICTED TO: -
 SCALE: 8:1 SHEET: 1 of 1 REV: B1