

PANASONIC BATTERIES



PANASONIC INDUSTRIAL EUROPE

Panasonic Corporation, founded in Osaka 1918, is one of the world's largest manufacturers of quality electronic and electrical equipment. Its subsidiary, Panasonic Industrial Europe GmbH (PIE) deals with a wide diversified range of industrial products for all European countries. This company was formed in 1998 to strengthen Panasonic's Pan-European industry operation, and today is active in such different business fields as Automotive, Audio/Video & Communication, Appliance and Industry & Devices to satisfy its customer's needs.



Panasonic quality - certified by authorised companies.

We are able to offer you a wide range of individual power solutions for portable and stationary applications. Our product range includes high reliability batteries such as Lithium-Ion, Lithium, Nickel-Metal-Hydrate, Valve-Regulated-Lead-Acid (VRLA), Alkaline and Zinc-Carbon. Based on this battery range we can power your business in virtually all applications.

Panasonic Energy Company (PEC) started its battery production in 1931. Today PEC is the most diversified global battery manufacturer with a network of 16 manufacturing companies in 14 countries. More than 12,600 employees are dedicated to the research & development and in the production of new batteries for a new world.

When it comes to production our facilities employ leading edge manufacturing processes meeting the highest quality standards. Our factories are certified to ISO standards. This means that each factory has its own quality and environmental management. The ISO 9000 and ISO 14000 series are the minimum benchmarks that ensure our excellent product reliability.

Furthermore the majority of our factories is also certified to OHSAS 18001 (Occupational Health and Safety Assessment Series), an international standard for assessing a management system for occupational safety. This confirms that our factories have been proactive in putting the occupational health and safety of its staff at the centre of the company's dealings. In addition our VRLA batteries are for example approved to German VdS standard and U.S. UL standard.

PIE Organisation Divisions

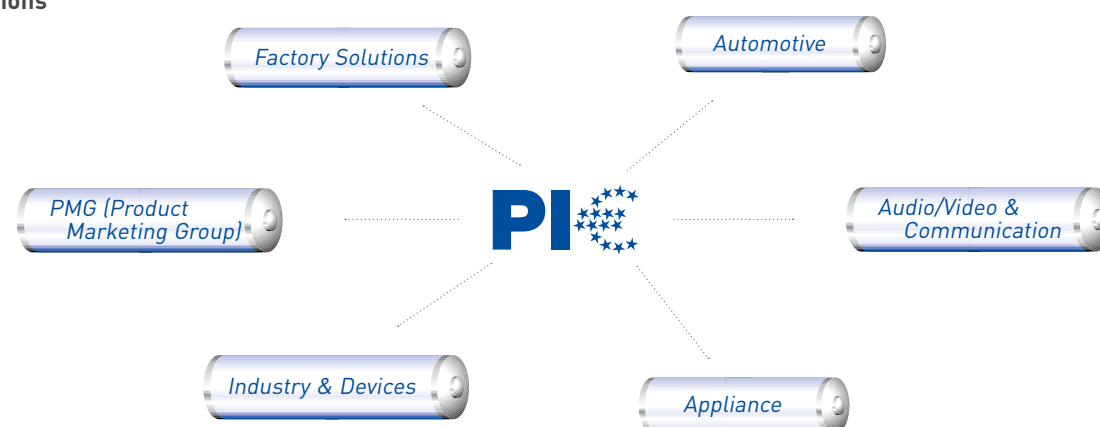



PANASONIC LEADS THE WAY ... WITH 'ECO IDEAS'

Pursuing coexistence with the global environment in its business vision, Panasonic places reduction of the environmental impact in all its business activities as one of the important themes in its mid-term management plan. In its 'eco ideas' Strategy, which focuses in particular on rapid implementation of measures to prevent global warming and global promotion of environmental sustainability management, Panasonic is advancing three key initiatives: 'eco ideas' for Manufacturing, 'eco ideas' for Products, and 'eco ideas' for Everybody, Everywhere.

Our **energy** will Drive **eco** Innovation.

The Panasonic 'eco ideas' House

We are approaching a global turning corner and it would not be an exaggeration to call it the 'Environmental Industrial Revolution'. Based on this recognition, Panasonic has built an 'eco ideas' House on the premise of our showroom, Panasonic Center Tokyo in April 2009 in order to help create a carbon-free society and reduce CO₂ emissions from a household sector.

The concept of this 'eco ideas' House can be described as follows:

1. Virtually zero CO₂ emissions in an entire house envisaged in three to five years into the future
 2. Synergy of technology and nature
- Aforementioned concepts shows that Panasonic is not only aware of it's environmental responsibility moreover this Panasonic takes action.

'ECO IDEAS' FOR MANUFACTURING

Our plans

We will reduce CO₂ emissions across all our manufacturing sites.

Our goals

In each of our factories a CO₂ emissions of 10% reduction till 2010.

Our measures

Our factories are evaluated with regard to CO₂ emission, waste disposal, recycling measures as well as chemical and water consumption within the scope of the 'Clean Factory' program and they are set performance targets according to these indicators.

Example

The Wakayama Plant of the Energy Company is strengthening its management structure to cut CO₂ emissions from the main production bases for Lithium-Ion batteries, which are a core component of Panasonic's energy business. As a result, it has succeeded in roughly halving CO₂ emissions per production unit, as well as sharply curbing an increase in CO₂ emissions even as production has expanded.

'ECO IDEAS' FOR PRODUCTS

Our plans

We will produce energy-efficient products.

Our goals

In March 2010 at least 20 products with the 'Superior Green Products' classification should be available.

Our measures

The developers at Panasonic carry out an environmental impact assessment for all our products. Products that meet the highest environmental requirements in the branch with regard to conservation of energy and energy efficiency are classified as a 'Superior Green Product' and awarded the Panasonic logo 'eco ideas'.

Example

We have dispensed with the use of highly toxic Lithium Thionyl Chloride in the production of our Lithium batteries. This is quite rightly classified as highly toxic and should never under any circumstances be released into the environment.

'ECO IDEAS' FOR EVERYBODY, EVERYWHERE

Our plans

We will encourage the spread of environmental activities throughout the world.

Our goals

Intensive commitment on the part of the company owners, international cooperations and involvement of the employees.

Our measures

Not only do we sponsor the work of the WWF for the Arctic, Panasonic has also launched a couple of other environmental initiatives such as the ECO RELAY initiative in which hundreds of colleagues the world over take part voluntarily for several days in environmental campaigns.

Example

With the support of the GRS Batterien (German Battery Recycling Association) Panasonic arranged a battery collection day with the aim of collecting as many of these spent energy sources as possible and giving out information about the recycling loop of batteries from which valuable raw materials such as Zinc, Manganese and Iron can be recovered.

Chapter	Page
1 Precautions for designing devices with Ni-MH batteries	
Charging	7
Discharging	7
Storage	8
Service life of batteries	8
Design of products which use batteries	8 – 9
Prohibited items regarding the battery handling	9 – 10
Other precautions	10
Ni-MH battery transportation situation	10
Final point to keep in mind	10
2 Product safety data sheet	11
3 Ni-MH batteries	
Overview	12
Construction	12
Applications	12
Structure of Ni-MH batteries	13
The principle of electrochemical reaction involved in Ni-MH batteries	13 – 14
Features	14
Five main characteristics	14 – 16
4 Charge methods for Ni-MH batteries	
Charge methods	17 – 18
Ni-MH high-temperature series recommended charge for back-up power applications	18
5 Battery selection	19
6 Specification table	20
7 Individual data sheets	21 – 44
8 Battery packs	45
9 Glossary of terms for Ni-MH batteries	46 – 47

In order to take full advantage of the properties of Ni-MH batteries and also to prevent problems due to improper use, please note the following points during the use and design of battery operated products.

CHARGING

Charging temperature

Charge batteries within an ambient temperature range of 0°C to 40°C. Ambient temperature during charging affects charging efficiency. As charging efficiency is best within a temperature range of 10°C to 30°C, whenever possible place the charger (battery pack) in a location within this temperature range.

At temperatures below 0°C the gas absorption reaction is not adequate, causing gas pressure inside the battery to rise, which can activate the safety vent and lead to leakage of alkaline gas and deterioration in battery performance.

Charging efficiency drops at temperatures above 40°C. This can disrupt full charging and lead to deterioration in performance and battery leakage.

Parallel charging of batteries

Sufficient care must be taken during the design of the charger when charging batteries connected in parallel. Consult Panasonic when parallel charging is required.

Reverse charging

Never attempt reverse charging. Charging with polarity reversed can cause a reversal in battery polarity causing gas pressure inside the battery to rise, which can activate the safety vent, lead to alkaline electrolyte leakage, rapid deterioration in battery performance, battery swelling or battery rupture.

Overcharging

Avoid overcharging. Repeated overcharging can lead to deterioration in battery performance. ('Overcharging' means charging a battery when it is already fully charged.)

Rapid charging

To charge batteries rapidly, use the specified charger (or charging method recommended by Panasonic) and follow the correct procedures.

Trickle charging (continuous charging)

Trickle charging cannot be used with Ni-MH batteries, except specific high temperature batteries (please contact Panasonic to get more information). However, after applying a refresh charge using a rapid charge, use a trickle charge of 0.033CmA to 0.05CmA. Also, to avoid overcharging with trickle charge, which could damage the cell characteristics, a timer measuring the total charge time should be used.

Note: 'CmA'

During charging and discharging, 'CmA' is a value indicating current and expressed as a multiple of nominal capacity. Substitute 'C' with the battery's nominal capacity when calculating. For example, for a 1500mAh battery of 0.033CmA, this value is equal to 1/30 x 1500, or roughly 50mA.

DISCHARGING

Discharge temperature

Discharge batteries within an ambient temperature range of -10°C to +45°C.

Discharge current level (i. e. the current at which a battery is discharged) affects discharging efficiency. Discharging efficiency is good within a current range of 0.1CmA to 2CmA.

Discharge capacity drops at temperatures below -10°C or above +45°C. Such decreases in discharge capacity can lead to deterioration in battery performance.

Overdischarge (deep discharge)

Since overdischarging (deep discharge) damages the battery characteristics, do not forget to turn off the switch when discharging, and do not leave the battery connected to the equipment for long periods of time. Also, avoid shipping the battery installed in the equipment.

High-current discharging

As high-current discharging can lead to heat generation and decreased discharging efficiency, consult Panasonic before attempting continuous discharging or pulse discharging at currents larger than 2CmA.

STORAGE

Storage temperature and humidity (short-term)

Store batteries in a dry location with low humidity, no corrosive gases, and at a temperature range of -20°C to +45°C. Storing batteries in a location where humidity is extremely high or where temperatures fall below -20°C or rise above +45°C can lead to the rusting of metallic parts and battery leakage due to expansion or contraction in parts composed of organic materials.

Long-term storage (1 year, -20°C to +35°C)

Because long-term storage can accelerate battery self-discharge and lead to the deactivation of reactants, locations where the temperature ranges between +10°C and +30°C are suitable for long-term storage.

When charging for the first time after long-term storage, deactivation of reactants may lead to increased battery voltage and decreased battery capacity. Restore such batteries to original performance by repeating several cycles of charging and discharging.

When storing batteries for more than 1 year, charge at least once a year to prevent leakage and deterioration in performance due to selfdischarging.

SERVICE LIFE OF BATTERIES

Cycle life

Batteries used under proper conditions of charging and discharging can be used 500 cycles or more. Significantly reduced service time in spite of proper charging means that the life of the battery has been exceeded.

Also, at the end of service life, an increase in internal resistance, or an internal short-circuit failure may occur. Chargers and charging circuits should therefore be designed to ensure safety in the event of heat generated upon battery failure at the end of service life.

Service life with long-term use

Because batteries are chemical products involving internal chemical reactions, performance deteriorates not only with use but also during prolonged storage.

Normally, a battery will last 2 years (or 500 cycles) if used under proper conditions and not overcharged or overdischarged. However, failure to satisfy conditions concerning charging, discharging, temperature and other factors during actual use can lead to shortened life (or cycle life) damage to products and deterioration in performance due to leakage and shortened service life.

DESIGN OF PRODUCTS WHICH USE BATTERIES

Connecting batteries and products

Never solder a lead wire and other connecting materials directly to the battery, as doing so will damage the battery's internal safety vent, separator, and other parts made of organic materials. To connect a battery to a product, spot-weld a tab made of nickel or nickel-plated steel to the battery's terminal strip, then solder a lead wire to the tab.

Perform soldering in as short a time as possible.

Use caution in applying pressure to the terminals in cases where the battery pack can be separated from the equipment.

Material for terminals in products using the batteries

Because small amounts of alkaline electrolyte can leak from the battery seal during extended use or when the safety vent is activated during improper use, a highly alkaline-resistant material should be used for a product's contact terminals in order to avoid problems due to corrosion.

High alkaline-resistant metals	Low alkaline-resistant metals
Nickel, stainless steel, nickel-plated steel, etc.	Tin, aluminum, zinc, copper, brass, etc.

(Note that stainless steel generally results in higher contact resistance.)

Temperature related the position of batteries in products

Excessively high temperatures (i.e. higher than 45°C) can cause alkaline electrolyte to leak from the battery, thus damaging the product and shorten battery life by causing deterioration in the separator or other battery parts. Install batteries far from heat-generating parts of the product. The best battery position is in a battery compartment that is composed of an alkaline-resistant material which isolates the batteries from the product's circuitry. This prevents damage that may be caused by a slight leakage of alkaline electrolyte from the battery.

Discharge end voltage

The discharge end voltage is determined by the formula given below. Please set the end voltage of each battery at 1.1 volts or less.

Number of batteries arranged serially	
1 to 6	(Number of batteries x 1.0) V
7 to 12	(Number of batteries - 1) x 1.2) V

Overdischarge (deep discharge) prevention

Overdischarging (deep discharging) or reverse charging damages the battery characteristics. In order to prevent damage associated with forgetting to turn off the switch or leaving the battery in the equipment for extended periods, preventative options should be incorporated in the equipment. At the same time, it is recommended that leakage current is minimized. Also, the battery should not be shipped inside the equipment.

PROHIBITED ITEMS REGARDING THE BATTERY HANDLING

Panasonic assumes no responsibility for problems resulting from batteries handled in the following manner.

Disassembly

Never disassemble a battery, as the electrolyte inside is strong alkaline and can damage skin and clothes.

Short-circuiting

Never attempt to short-circuit a battery. Doing so can damage the product and generate heat that can cause burns.

Throwing batteries into a fire or water

Disposing of a battery in fire can cause the battery to rupture. Also avoid placing batteries in water, as this causes batteries to cease to function.

Soldering

Never solder anything directly to a battery. This can destroy the safety features of the battery by damaging the safety vent inside the cap.

Inserting the batteries with their polarities reversed

Never insert a battery with the positive and negative poles reversed as this can cause the battery to swell or rupture.

Overcharging at high currents and reverse charging

Never reverse charge or overcharge with high currents (i.e. higher than rated). Doing so causes rapid gas generation and increased gas pressure, thus causing batteries to swell or rupture.

Charging with an unspecified charger or specified charger that has been modified can cause batteries to swell or rupture. Be sure to indicate this safety warning clearly in all operating instructions as a handling restriction for ensuring safety.

Installation in equipment (with an airtight battery compartment)

Always avoid designing airtight battery compartments. In some cases, gases (oxygen, hydrogen) may be given off, and there is a danger of the batteries bursting or rupturing in the presence of a source of ignition (sparks generated by a motor switch, etc.).

Use of batteries for other purposes

Do not use a battery in an appliance or purpose for which it was not intended. Differences in specifications can damage the battery or appliance.

Short-circuiting of battery packs

Special caution is required to prevent short circuits. Care must be taken during the design of the battery pack shape to ensure batteries cannot be inserted in reverse. Also, caution must be given to certain structures or product terminal shapes which can make short-circuiting more likely.

Using old and new batteries together

Avoid using old and new batteries together. Also avoid using these batteries with ordinary dry-cell batteries, Ni-Cd batteries or with another manufacturer's batteries. Differences in various characteristic values, etc., can cause damage to batteries or the product.

OTHER PRECAUTIONS

Batteries should always be charged prior to use. Be sure to charge correctly.

NI-MH BATTERY TRANSPORTATION SITUATION*1**Transport by sea**

Ni-MH batteries are classified as no dangerous goods under IMDG-Code 34-08 (International Maritime Dangerous Goods Code), valid until 31.12.2011.

From 01.01.2012 new UN 3496 takes place under IMDG-Code 35-10 with Special Provision 963. Ni-MH batteries are then classified as dangerous goods in class 9. Batteries shall be securely packed and protected from short circuit.

When loaded in a cargo transport unit with 100kg gross mass or more, special stowage is requested away from heat source. Furthermore an information on the IMO (International Maritime Organization) document is required.

Transport by air

As of today there are no fixed regulations for the worldwide transportation of Ni-MH batteries by air.

Transport by road

As of today there are no fixed regulations for the worldwide transportation of Ni-MH batteries by road.

FINAL POINT TO KEEP IN MIND

In order to ensure safe battery use and to prolong the battery performance, please consult Panasonic regarding charge and discharge conditions for use and product design prior to the release of a battery-operated product.

PRODUCT SAFETY DATA SHEET*1**Manufacturer**

Name of Company: Panasonic Corporation Energy Company
Address: 1-1, Matsushita-cho, Moriguchi, Osaka 570-8511 Japan
Document number: PMH-PSDS-100129E
Issued: Jan, 29th, 2010

Name of product: Nickel-Metal-Hydride Storage Battery
(Model Name) The models described as HHR-*****

Substance identification

Substance: Nickel-Metal-Hydride Storage Battery
CAS No.: Not Specified.
UN Class: Classified as UN3028, but they are exempted from Dangerous Goods pursuant to UN Special Provision as below. Not restricted, as per Special Provision A123

[Special Provision 304] (UN Recommendations on the TRANSPORT OF DANGEROUS GOODS Model Regulations Volume 1. 15th revised edition) Battery, dry, containing corrosive electrolyte which will not flow out of the battery if the battery case is cracked are not subject to these Regulations provided the batteries are securely packed and protected against short-circuits. Examples of such batteries are: Alkali-Manganese, Zinc-Carbon, Nickel-Metal-Hydride and Nickel-Cadmium batteries.

Ecological information

Heavy metal quantity for cell: Hg < 0.5ppm Measurement Analysis: Atomic Absorption Spectrometer
Cd < 5.0ppm Measurement Analysis: Atomic Absorption Spectrometer
Pb < 40ppm Measurement Analysis: Atomic Absorption Spectrometer

Transport information

1. During the transportation of a large amount of batteries by ship, trailer or railway, do not leave them in the places of high temperatures and do not allow them to be exposed to dew condensation.
2. Avoid transportation with the possibility of the collapse of cargo piles and the packing damage.
3. Protect the terminals of batteries and prevent them from short circuit so as not to cause dangerous heat generation.

Regulatory information

- IATA Dangerous Goods Regulations 51th Edition Effective 1 January – 31 December 2010
- ICAO Technical Instructions for the safe transport of dangerous goods by air
- IATA (A123) for air shipment and IMDG (Special Provision) for sea shipment under UN3028

Others**References**

- Ni-Cd, Ni-MH Panasonic Catalogue and technical handbook.
- MSDS of Nickel hydro oxide and potassium hydro oxide and sodium hydro oxide from supplier.
- Recommendations on the TRANSPORT OF DANGEROUS GOODS Model Regulations Volume 1. 15th revised edition.
- IATA Dangerous Goods Regulations 51th Edition Effective 1 January – 31 December 2010
- Technical Instructions for the Safe Transport of Dangerous Goods by Air (Approved and published by decision of the Council of ICAO) 2003-2004 Edition



OVERVIEW

More and more electric products with sophisticated functions require extremely compact and light battery solutions delivering a high level of energy density. To meet these needs Panasonic Ni-MH batteries have been developed and manufactured with nickel hydroxide for the positive electrode and hydrogen-absorbing alloys, capable of absorbing and releasing hydrogen at high-density levels, for the negative electrode. The Ni-MH battery technology is nowadays the Ni-Cd (nickel cadmium) successor technology for rechargeable and portable devices. All of our Ni-MH batteries are cadmium-free, in order not to be harmful to human beings and our environment.

CONSTRUCTION

Ni-MH batteries consist of a positive plate containing nickel hydroxide as its principal active material, a negative plate mainly composed of hydrogen-absorbing alloys, a separator made of fine fibers, an alkaline electrolyte, a metal case and a sealing plate provided with a self-resealing safety vent. Their basic structure is identical to that of Ni-Cd batteries. With cylindrical Ni-MH batteries, the positive and negative plates are divided by the separator, wound into a coil, inserted into the case, and sealed by the sealing plate through an electrically insulated gasket, see page 13.

Panasonic expands the line of Ni-MH cells that are superior to standard Ni-MH products in applications with low-rate charge at high temperatures. Improvements were made in

existing Panasonic Ni-MH cells to the negative plate alloy and separator fiber density. A different electrolyte composition was achieved to improve performance. Superior long-life characteristics can be achieved when combined with appropriate intermittent charge control circuitry. The intermittent charge consumes 1/30th the electricity compared to trickle charge and more than doubles the expected life of the Ni-MH cells compared to Ni-Cd cells that have been trickle charged.

APPLICATIONS

Panasonic Ni-MH batteries can either be used for standard applications with a moderate ambient temperature or for applications which requires high temperature resistance.

Standard ambient temperature

E-Bikes, Pedelecs, Scooters, Golf-Trolleys, Powertools, Grape-Cutters, Multimeters, Voting Machine, Barcode Readers, Handheld Scanners, Labelprinters, Vacuum Cleaners, Muscle Electro-Stimulations, Toothbrushes, etc.

High temperature resistance (for back-up use)

Combined Solar Applications, Portable Medical Devices, POS Terminals, Emergency Light for buildings and trains, Elevator Safety Systems, etc.

STRUCTURE OF NI-MH BATTERIES

- 1 Positive pole
- 2 Top plate
- 3 Gasket
- 4 Safety vent
- 5 Collector
- 6 Separator
- 7 Cathode (nickel hydroxide)
- 8 Negative pole (cell can)
- 9 Anode (hydrogen – absorbing alloy)
- 10 Insulation plate
- 11 Exhaust gas hole
- 12 Tube

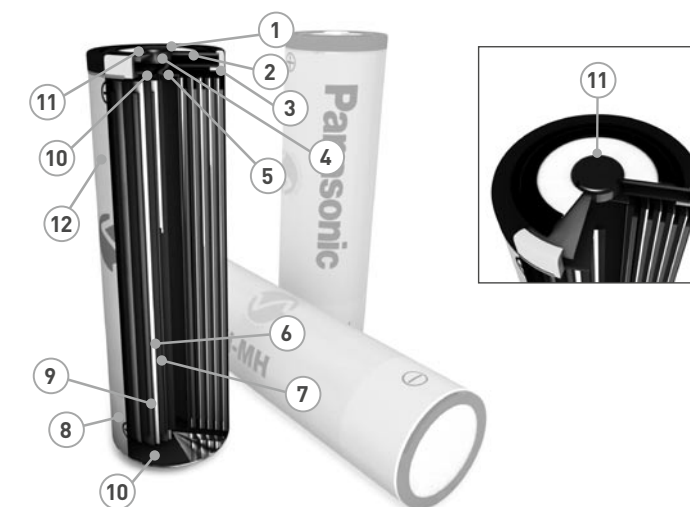

THE PRINCIPLE OF ELECTROCHEMICAL REACTION INVOLVED IN NI-MH BATTERIES

Hydrogen-absorbing alloys

Hydrogen-absorbing alloys have a comparatively short history which dates back about 20 years to the discovery of NiFe, MgNi and LaNi₅ alloys. They are capable of absorbing hydrogen equivalent to about a thousand times of their own volume, generating metal hydrides and also of releasing the hydrogen that they absorbed. These hydrogen-absorbing alloys combine metal (A) whose hydrides generate heat exothermically with metal (B) whose hydrides generate heat endothermically to produce the suitable binding energy so that hydrogen can be absorbed and released at or around normal temperature and pressure levels. Depending on how metals A and B are combined, the alloys are classified into the following types: AB (TiFe, etc.), AB₂ (ZnMn₂, etc.), AB₅ (LaNi₅, etc.) and A₂B (Mg₂Ni, etc.). From the perspective of charge and discharge efficiency and durability, the field of candidate metals suited for use as electrodes in storage batteries is now being narrowed down to AB₅ type alloys in which rare-earth metals, especially metals in the lanthanum group, and nickel serve as the host metals; and to AB₂ type alloys in which the titanium and nickel serve as the host metals. Panasonic is now focusing its attention on AB₅ type alloys which feature high capacity, excellent charge and discharge efficiency, and excellent cycle life. It has developed, and is now employing its own MmNi₅ alloy which uses Mm (misch metal – an alloy consisting of a mixture of rare-earth elements) for metal A.

Principle of electrochemical reaction involved in batteries

Ni-MH batteries employ nickel hydroxide for the positive electrode similar to Ni-Cd batteries. The hydrogen is stored in a hydrogen-absorbing alloy for the negative electrode, and an aqueous solution consisting mainly of potassium hydroxide for the electrolyte. Their charge and discharge reactions are shown below.

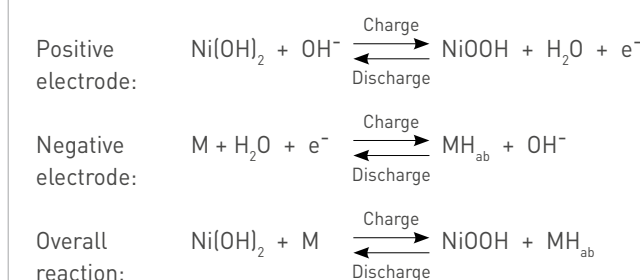

(M: hydrogen-absorbing alloy; H_{ab}: absorbed hydrogen)

As can be seen by the overall reaction given above, the chief characteristics of the principle behind a Ni-MH battery is that hydrogen moves from the positive to the negative electrode during charge and reverse during discharge, with the electrolyte taking no part in the reaction; which means that there is no accompanying increase or decrease in the electrolyte. A model of this battery's charge and discharge mechanism is shown in the figure on the following page. These are the useful reactions taking place at the respective boundary

faces of the positive and negative electrodes, and to assist one in understanding the principle, the figure shows how the reactions proceed by the transfer of protons (H+).

The hydrogen-absorbing alloy negative electrode successfully reduces the gaseous oxygen given off from the positive electrode during overcharge by sufficiently increasing the capacity of the negative electrode which is the same method employed by Ni-Cd batteries.

By keeping the battery's internal pressure constant in this manner, it is possible to seal the battery.

Schematic discharge of Ni-MH battery

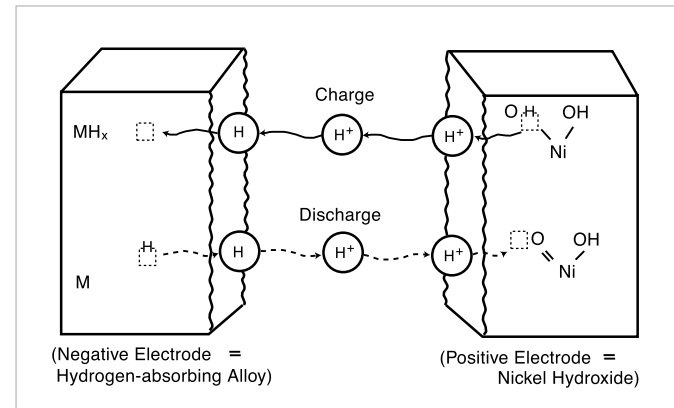

Cycle life equivalent to 500 charge and discharge cycles

Like Ni-Cd batteries, Ni-MH batteries can be repeatedly charged and discharged for about 500 cycles. (example: IEC charge and discharge conditions)

Rapid charge in approx. 1 hour

Ni-MH batteries can be rapidly charged in about an hour using a specially designed charger.

Excellent discharge characteristics

Since the internal resistance of Ni-MH batteries is low, continuous high-rate discharge up to 3CmA is possible.

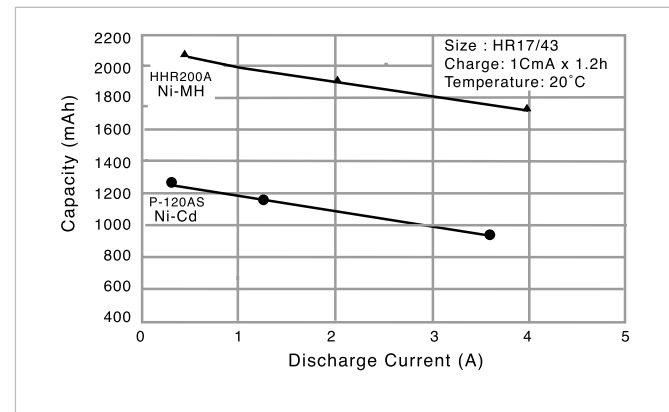

FEATURES

Similarity with Ni-Cd batteries

These batteries have similar discharge characteristics to those of Ni-Cd batteries.

Double the energy density of conventional batteries

Ni-MH batteries have approximately double the capacity compared with Panasonic's standard Ni-Cd batteries.

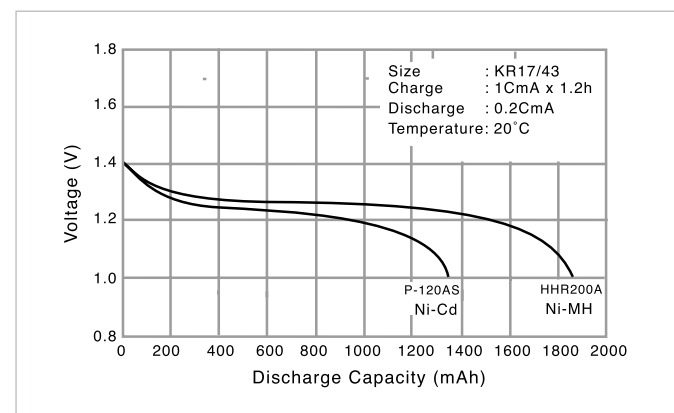

FIVE MAIN CHARACTERISTICS

As with Ni-Cd batteries, Ni-MH batteries have five main characteristics: charge, discharge, storage life, cycle life and safety.

1. Charge characteristics

The charge characteristics of Ni-MH batteries are affected by current, time and temperature. The battery voltage rises when the charge current is increased or when the temperature is low. The charge efficiency differs depending on the current, time, temperature and other factors. Ni-MH batteries should be charged at a temperature ranging from 0°C to 40°C using a constant current of 1C or less. The charge efficiency is particularly good at a temperature of 10°C to 30°C. Repeated charge at high or low temperatures causes the battery performance to deteriorate. Furthermore, repeated overcharge should be avoided since it will downgrade the battery performance. Refer to the section on recommended

charge methods for details on how to charge the batteries, see page 17-18.

Charge characteristics

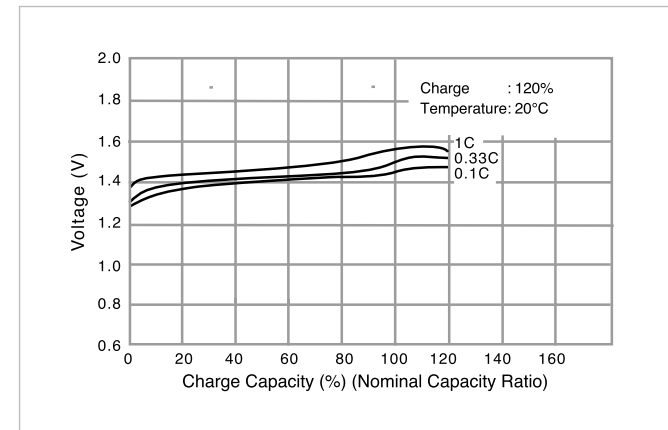

Charge temperature characteristics at 1C charge

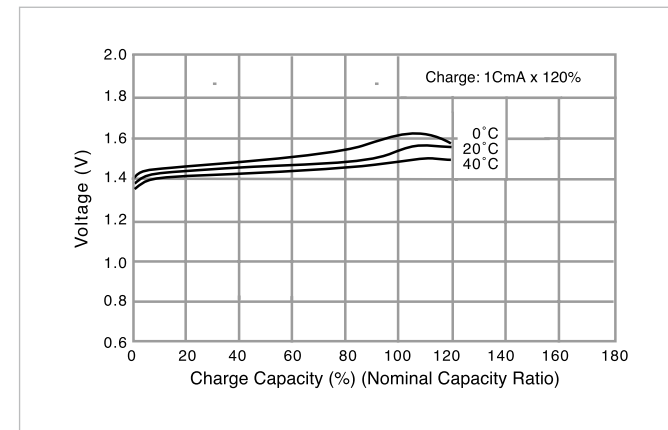

Charge temperature characteristics at various charge rates

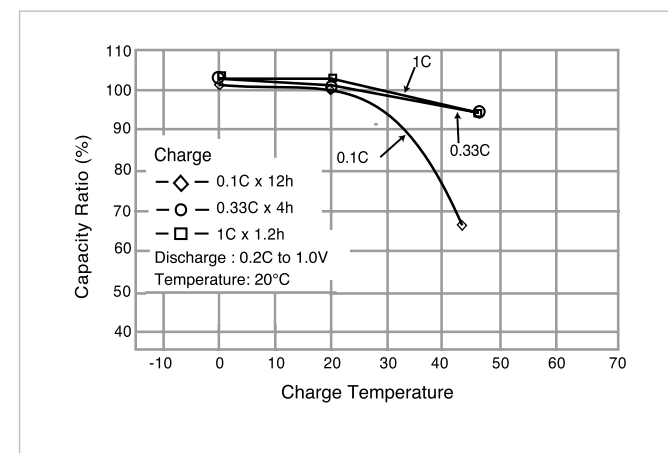

2. Discharge characteristics

The discharge characteristics of Ni-MH batteries are affected by current, temperature, etc., and the discharge voltage characteristics are flat at 1.2V, which is almost the

same as for Ni-Cd batteries. The discharge voltage and discharge efficiency decrease in proportion as the current rises or the temperature drops. As with Ni-Cd batteries, repeated charge and discharge of these batteries under high discharge cut-off voltage conditions (more than 1.1V per cell) causes a drop in the discharge voltage (which is sometimes accompanied by a simultaneous drop in capacity). The discharge characteristics can be restored by charge and discharge to a discharge end voltage of down to 1.0V per cell.

Discharge characteristics

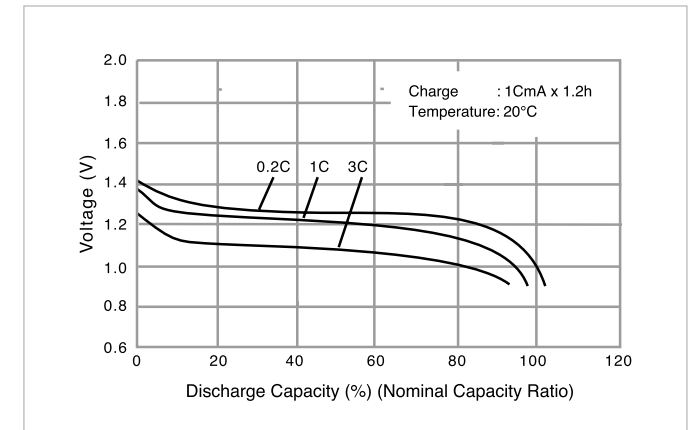

Discharge temperature characteristics at 1C discharge

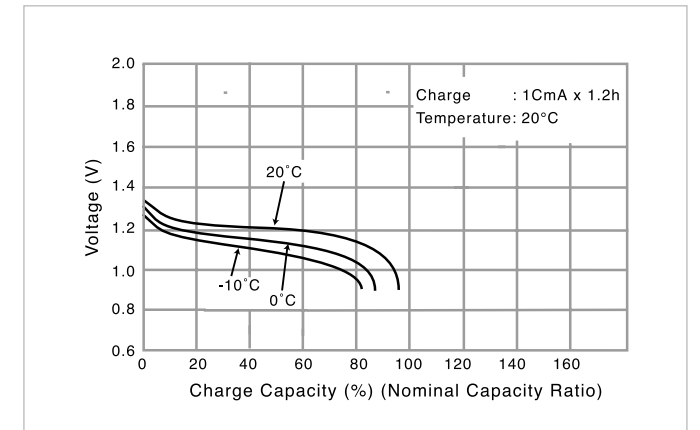

Discharge temperature characteristics

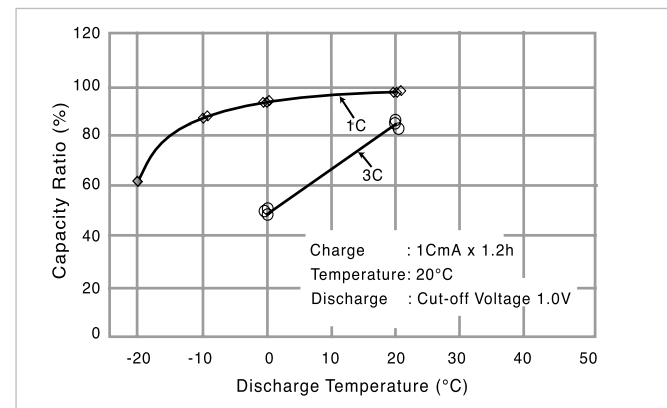

3. Storage characteristics

These characteristics include self-discharge characteristics and restoration characteristics after long-term storage. When batteries are left standing, their capacity generally drops due to self-discharge, but this is restored by charge.

Self discharge characteristics

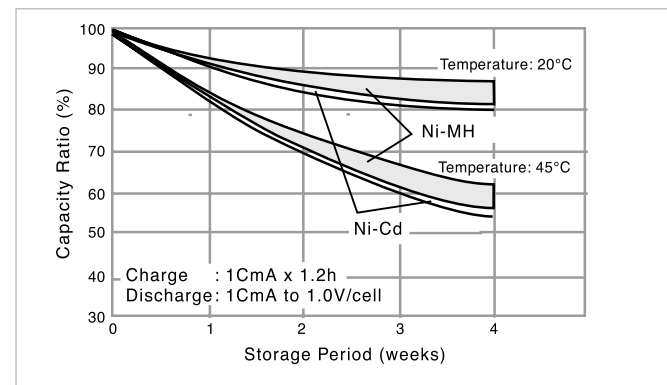

Self-discharge is affected by the temperature at which the batteries are left standing and the length of time during which they are left standing. It increases in proportion as the temperature or the shelf-standing time increases. Panasonic's Ni-MH batteries have excellent self-discharge characteristics.

4. Cycle life characteristics

The cycle life of these batteries is governed by the conditions under which they are charged and discharged, temperature and other conditions of use. Under proper conditions of use (example: IEC charge and discharge conditions), these batteries can be charged and discharged for more than 500 cycles.

Cycle life characteristics

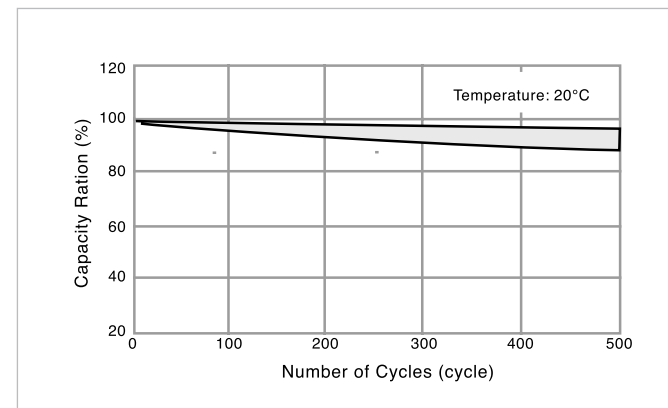

5. Safety

When the internal pressure of these batteries rises due to overcharge, short-circuiting, reverse charge or other abuse or misuse, the self-sealing safety vent is activated to prevent battery damage.

CHARGE METHODS

Charge is the process of restoring a discharged battery to its original capacity. In order for a battery to be usable for a long period of time, it must be charged via the proper charge method. Various methods are used to charge rechargeable cells, but Panasonic recommends the charge methods described below to charge its Ni-MH batteries.

1. Rapid charge current: 1CmA (rapid charge temperature range: 0°C to 40°C). In order to exercise proper control to stop rapid charge, it is recommended that batteries be charged at over 0.5CmA but less than 1CmA. Charging batteries at a current in excess of 1CmA may cause the safety vent to be activated by a rise in the internal pressure of the batteries, thereby resulting in electrolyte leakage. When the temperature of the batteries is detected by a thermistor or other type of sensor, and their temperature is under 0°C or over 40°C at the commencement of the charge, then trickle charge, rather than rapid charge, must be performed. Rapid charge is stopped when any one of the values among the types of control described in [4], [5], [6], and [11] reaches the prescribed level.

2. Allowing a high current: to flow to excessively discharged or deep-discharged batteries during charge may make it impossible to sufficiently restore the capacity of the batteries. To charge excessively discharged or deep-discharged batteries, first allow a trickle current to flow, and then proceed with the rapid charge current once the battery voltage has risen.

3. Rapid charge start voltage: Approx. 0.8V/cell rapid charge transition voltage restoration current: 0.2 ~ 0.3CmA

4. Upper battery voltage limit control: Approx. 1.8V/cell. The charge method is switched over to trickle if the battery voltage reaches approximately 1.8V/cell due to trouble or malfunctioning of some kind.

5. ΔV value: 5 to 10mV/cell. When the battery voltage drops from its peak to 5 to 10mV/cell during rapid charge, rapid charge is stopped, and the charge method is switched over to trickle charge.

6. dT/dt value: Approx. 1 to 2°C/min. When a rise in the battery temperature per unit time is detected by a thermistor or other type of temperature sensor during rapid charge, and the prescribed temperature rise is sensed, rapid charge is stopped and the charge method is switched over to trickle charge.

7. Temperature cut-off (TCO): 55°C (for A and AA size), 50°C (for AAA size), 60°C (for L-A, LfatA and SC size). The cycle life and other characteristics of batteries are impaired if the batteries are allowed to become too hot during charge. In order to safeguard against this, rapid charge is stopped and the charge method is switched over to trickle charge when the battery temperature has reached the prescribed level.

8. Initial delay timer: to 10 min. This prevents the $-\Delta V$ detection circuit from being activated for a specific period of time after rapid charge has commenced. However, the dT/dt detection circuit is allowed to be activated during this time. As with Ni-Cd batteries, the charge voltage of Ni-MH batteries may show signs of swinging (pseudo $-\Delta V$) when they have been kept standing for a long time or when they have discharged excessively, etc. The initial delay timer is needed to prevent charge from stopping (to prevent malfunctioning) due to this pseudo $-\Delta V$.

9. Trickle current: 0.033 to 0.05CmA. When the trickle current is set higher, the temperature rise of the batteries is increased, causing the battery characteristics to deteriorate.

10. Rapid charge transfer timer: 60 min.

11. Rapid charge timer: 90 min. (at 1C charge)

12. Total timer: 10 to 20 hours. The overcharging of Ni-MH batteries, even by trickle charging, causes a deterioration in the characteristics of the batteries. To prevent overcharging by trickle charging or any other charging method, the provision of a timer to regulate the total charging time is recommended.

Note: The temperature and voltage of Ni-MH batteries varies depending on the shape of the battery pack, the number of cells, the arrangement of the cells and other factors. Therefore

Panasonic should be consulted for more detailed information on the referenced charge control values. The charge methods described previously can be applied also when Ni-MH batteries are employed in a product, but Panasonic should be consulted for the control figures and other details.

Recommended Ni-MH battery charge system*1	
1. Rapid charge current	Max. 1CmA to 0.5CmA
2. Rapid charge transition voltage restoration current	0.2 to 0.3CmA
3. Rapid charge start voltage	Approx. 0.8V/cell
4. Charge terminating voltage	1.8V/cell
5. ΔV value	5 to 10mV/cell
6. Battery temperature rising rate dT/dt value	1 to 2°C/min
7. Maximum battery temperature TCO	60°C (for L-A, L-fatA and SC size) 55°C (for A, AA and D size) 50°C (for QA, AAA and prismatic size)
8. Initial $-\Delta V$ detection disabling timer	5 to 10 min
9. Trickle current (after rapid charge)	0.033 to 0.05CmA
10. Rapid charge transfer timer	60 min
11. Rapid charge timer	90 min (at 1CmA charge)
12. Total timer	10 to 20 hours
13. Rapid charge temperature range	0° to 40°C

Example of a rapid charge system

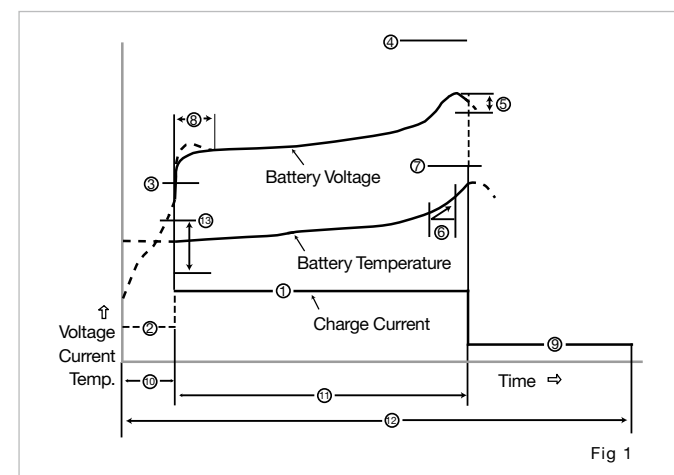

Basic pack configuration circuit

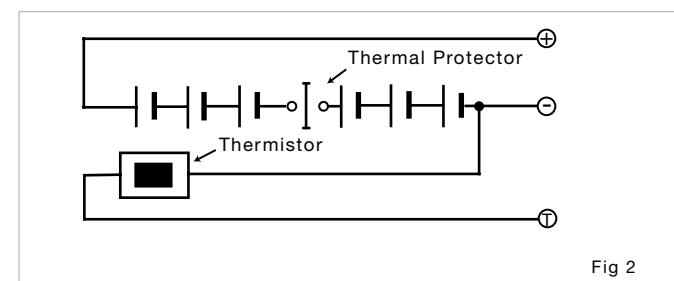

NI-MH HIGH-TEMPERATURE SERIES RECOMMENDED CHARGE FOR BACK-UP POWER APPLICATIONS

The optimal charge system for the Ni-MH "H" Series for back-up power applications is an intermittent timer charge. An intermittent timer charge improves charge efficiency, extends battery life [-vs- trickle charge] and reduces electricity consumption up to 30% compared to trickle charge*2.

Intermittent timer charge: (See diagram) At the beginning of the charge, an IC timer is started and charging is activated at a current of 0.1It until the timer stops and the charge is terminated. When the batteries self discharge down to a set point (1.3V), the timer charge is re-activated.

Example of intermittent timer charger system:

Average charge current: 0.1ItA

Re-charge time: 16 hours

Pulse charging can be used

Intermittent charge

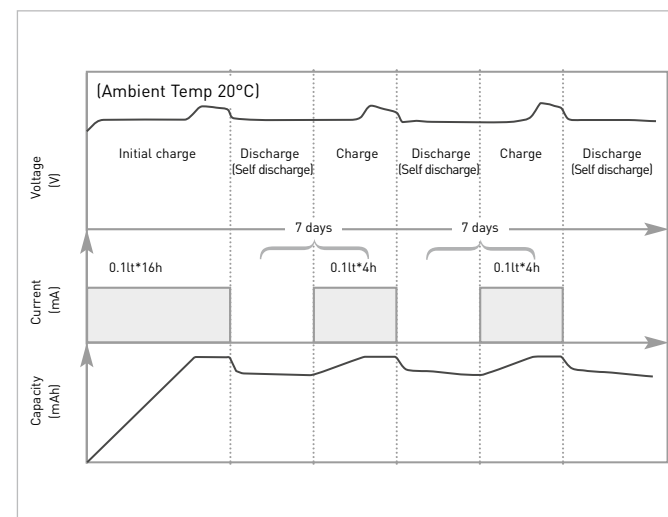

THE STEPS FOR SELECTING A TYPE OF BATTERY FOR USE AS THE POWER SUPPLY OF A DEVICE ARE SHOWN BELOW:

Study of the proposed required specifications

Verify the battery specifications required for the power supply of the device and use those conditions as the standards for battery selection. For reference, the technological factors concerning battery selection are shown below.

Battery selection

Using the catalogs and data sheets for the batteries currently produced and marketed, narrow down the number of

candidates to a few battery types. From those candidates, select the one battery that most closely satisfies the ideal conditions required. In actual practice, the selection of a battery is rarely completed as easily as this. In most cases it is necessary to consider eliminating or relaxing some of the proposed specifications, and then select the most suitable battery from among those currently available to meet the adjusted conditions. This process makes it possible to select more economical batteries. If you have any doubts at this stage, consult closely with a battery engineer. In some cases, newly improved or newly developed batteries that are not yet listed in the catalog may be available. Normally the required specifications are also finalized at this stage.

TECHNOLOGICAL FACTORS CONCERNING BATTERY SELECTION

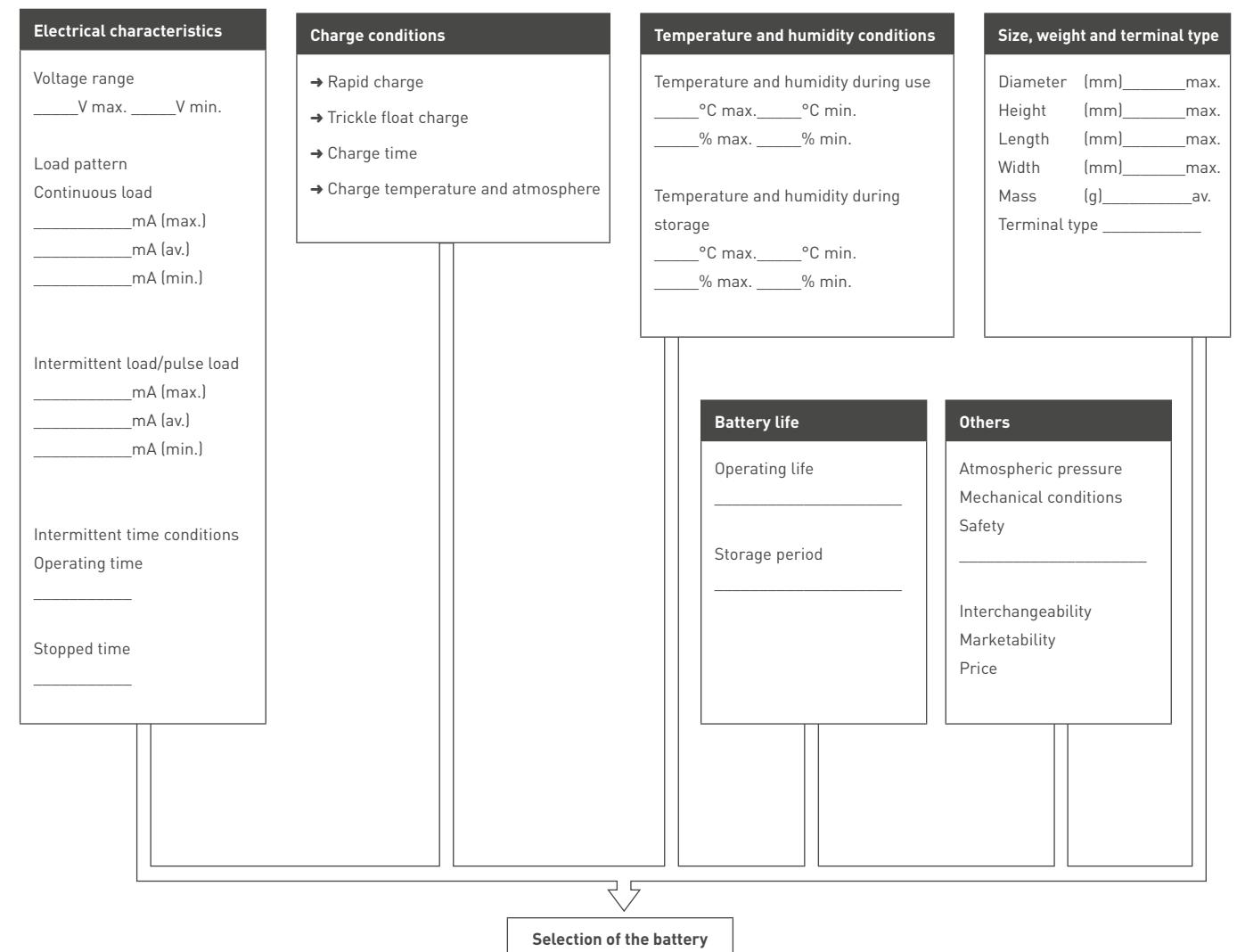

*1 Matching test is required because these values vary depending on rapid charge current, number of cells, configuration of battery pack, etc.

*2 Trickle charge is not recommended in general for Ni-MH batteries. Please consult Panasonic on any Ni-MH applications requiring trickle charge.

CYLINDRICAL

Model	Diameter	Size	Nominal voltage (V)	Discharge capacity*1 (mAh)		Dimensions with tube (mm)		Approx. weight (g)	IEC	Page
				Average*2	Rated/min.	Diameter	Height			
HHR-70AAA/FT	AAA	AAA	1.2	730	700	10.5 +0/-0.7	44.5 +0/-1.0	12	HR11/45	21
HHR-75AAA/HT*3	AAA	AAA	1.2	730	700	10.5 +0/-0.7	44.5 +0/-1.0	12	HR11/45	22
HHR-80AAA/HT*3	AAA	AAA	1.2	780	750	10.5 +0/-0.7	44.5 +0/-1.0	13	HR11/45	23
HHR-35AA/FT	AA	2/3AA	1.2	390	350	14.5 +0/-0.7	28.5 +0/-1.0	10.5	-	24
HHR-120AA/FT	AA	4/5AA	1.2	1,220	1,150	14.5 +0/-0.7	43.0 +0/-1.0	23	HR15/43	25
HHR-70AA/FT	AA	AA	1.2	780	700	14.5 +0/-0.7	48.8 +0/-1.5	21	HR15/49	26
HHR-70AA/HT*4	AA	AA	1.2	780	700	14.5 +0/-0.7	50.5 +0/-1.5	21	HR15/49	27
HHR-110AA/FT	AA	AA	1.2	1,180	1,100	14.5 +0/-0.7	50.0 +0/-1.0	24	HR15/51	28
HHR-150AA/FT	AA	AA	1.2	1,580	1,500	14.5 +0/-0.7	50.0 +0/-1.0	26	HR15/51	29
HHR-210AA/HT*4	AA	AA	1.2	2,080	2,000	14.5 +0/-0.7	50.5 +0/-1.0	29	HR15/51	30
HHR-200A/FT	A	4/5A	1.2	2,040	2,000	17.0 +0/-0.7	43.0 +0/-1.5	32	HR17/43	31
HHR-210A/FT	A	A	1.2	2,200	2,100	17.0 +0/-0.7	50.0 +0/-1.5	38	HR17/50	32
HHR-380A/FT	A	L-A	1.2	3,800	3,700	17.0 +0/-0.7	67.0 +0/-1.5	53	HR17/67	33
HHR-450A/FT	A	LFat/A	1.2	4,500	4,200	18.2 +0/-0.7	67.0 +0/-1.5	60	-	34
HHR-200SCP/FT*5	SC	4/5SC	1.2	2,100	1,900	23.0 +0/-1.0	34.0 +0/-1.5	43	-	35
HHR-260SCP/FT*5	SC	SC	1.2	2,600	2,450	23.0 +0/-1.0	43.0 +0/-1.5	55	HR23/43	36
HHR-300SCP/FT*5	SC	SC	1.2	3,050	2,800	23.0 +0/-1.0	43.0 +0/-1.5	57	HR23/43	37

CYLINDRICAL FOR BACK-UP USE (HIGH TEMPERATURE TYPE)

Model	Diameter	Size	Nominal voltage (V)	Discharge capacity*1 (mAh)		Dimensions with tube (mm)		Approx. weight (g)	IEC	Page
				Average*2	Rated/min.	Diameter	Height			
HHR-60AAA/FT	AAA	AAA	1.2	550	500	10.5 +0/-0.7	44.5 +0/-1.0	13	HR11/45	38
HHR-70AAH/FT	AA	AA	1.2	750	700	14.5 +0/-0.7	48.3 +0/-1.0	18	HR15/49	39
HHR-210AH/FT	A	A	1.2	2,050	1,900	17.0 +0/-0.7	50.0 +0/-1.5	36	HR17/50	40
HHR-330APH/FT*5	A	LFat/A	1.2	3,300	3,200	18.2 +0/-0.7	67.0 +0/-1.5	60	-	41
HHR-370AH/FT	A	LFat/A	1.2	3,700	3,500	18.2 +0/-0.7	67.0 +0/-1.5	60	-	42
HHR-250SCH/FT*5	SC	SC	1.2	2,650	2,500	23.0 +0/-1.0	43.0 +0/-1.5	55	HR23/43	43
HHR-300CH/FT*5	C	C	1.2	3,300	3,100	26.0 +0/-1.0	50.0 +0/-2.0	80	HR26/50	44

E-BLOCK

Model	Diameter	Nominal voltage (V)	Discharge capacity*1 (mAh)		Dimensions with tube (mm)			Approx. weight (g)	IEC
			Average*2	Rated/min.	Diameter	Height	Thickness		
HHR-9SRE/BA1	E-Block	8.4	175	170	26.0	48.5	16.3	42	-

Model number (example)

H H R - 6 0 A A A H / F T

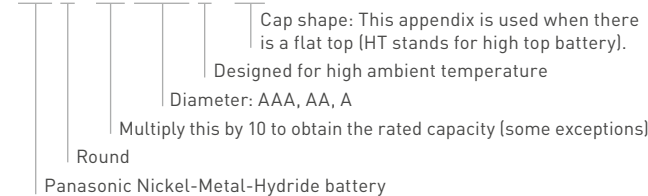

*1 After charging at 0.1CmA for 16 hours, discharging at 0.2CmA.
 *2 For reference only.
 *3 Compatible with consumer AAA size.
 *4 Compatible with consumer AA size.
 *5 For high power use applications such as Powertools.

HHR-70AAA/FT CYLINDRICAL AAA SIZE (HR11/45)

DIMENSIONS (MM)

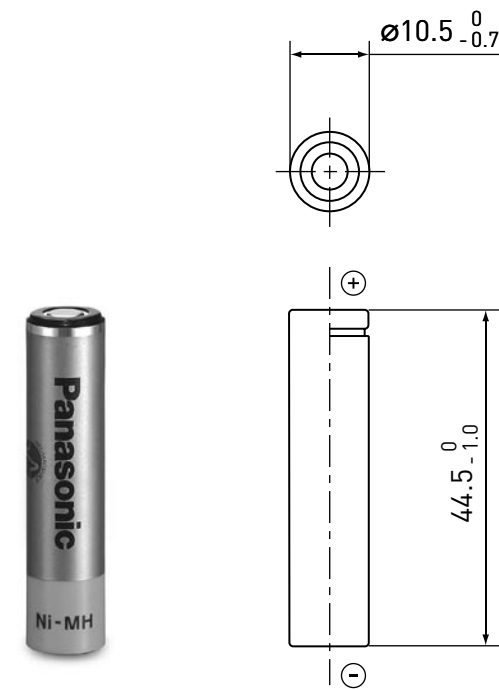

SPECIFICATIONS

Name	HHR-70AAA/FT	
Diameter (mm)	10.5 +0 / -0.7	
Height (mm)	44.5 +0 / -1.0	
Approximate weight (g)	12	
Nominal voltage (V)	1.2	
Discharge capacity*1	Average*2 (mAh) 730 Rated (min) (mAh) 700	
Approx. internal impedance at 1,000Hz at charged state (mΩ)	30	
Charge	Standard (mA x hrs.) 70 x 16 Rapid*3 (mA x hrs.) 700 x 1.2	
Ambient temperature	Charge	Standard (°C) 0 to +45 Rapid (°C) 0 to +40
	Discharge (°C)	-10 to +65
	Storage	<1 year -20 to +35 <6 months -20 to +45 <1 month -20 to +55

*1 After charging at 0.1It for 16 hours, discharging at 0.2It.
 *2 For reference only.
 *3 Need specially designed control system. Please contact Panasonic for details.

TYPICAL CHARGE CHARACTERISTICS

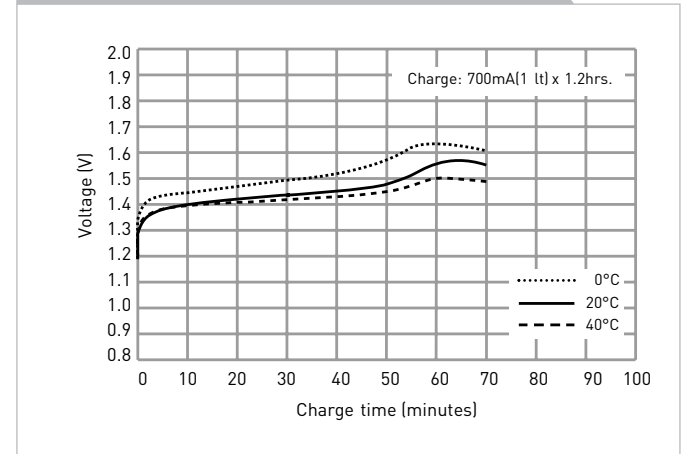

TYPICAL DISCHARGE CHARACTERISTICS

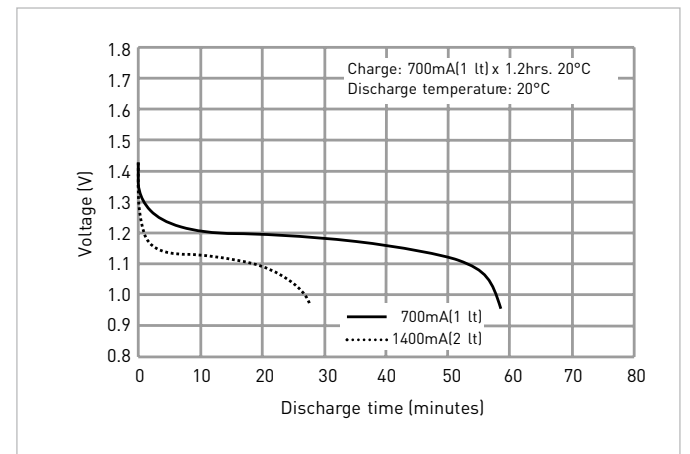
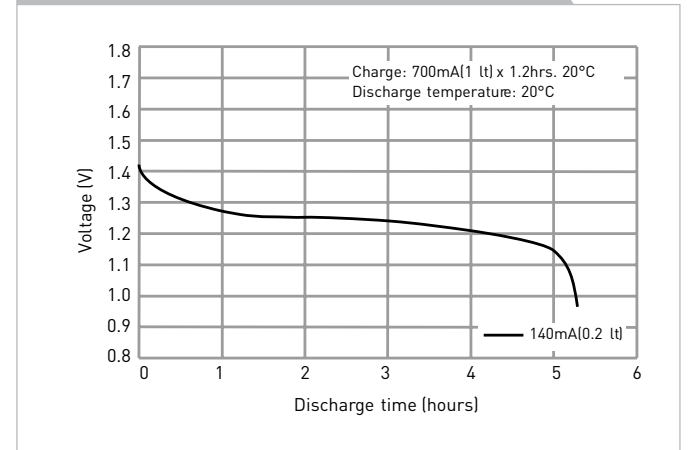

Battery performance and cycle life are strongly affected by how they are used. In order to maximize battery safety, please consult Panasonic when determining charge/discharge specs, warning label contents and design. The data in this document are for descriptive purposes only and are not intended to make or imply any guarantee or warranty.

INDIVIDUAL DATA SHEETS

HHR-75AAA/HT CYLINDRICAL AAA SIZE (HR11/45)

DIMENSIONS (MM)

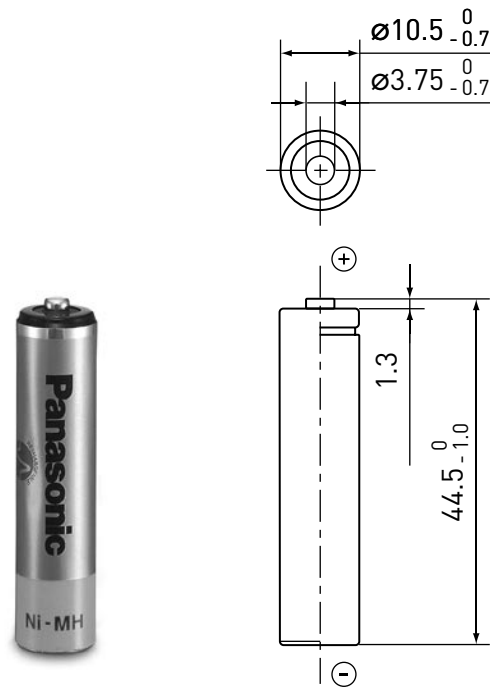

SPECIFICATIONS

Name	HHR-75AAA/HT	
Diameter (mm)	10.5 +0/-0.7	
Height (mm)	44.5 +0/-1.0	
Approximate weight (g)	12	
Nominal voltage (V)	1.2	
Discharge capacity*1	Average*2 (mAh)	730
	Rated/min. (mAh)	700
Approx. internal impedance at 1,000Hz at charged state (mΩ)	35	
Charge	Standard (mA x hrs.)	70 x 16
	Rapid*3 (mA x hrs.)	450 x 1.7
Ambient temperature	Charge (°C)	Standard: 0 to +45 Rapid: 0 to +40
	Discharge (°C)	-10 to +65
Storage (°C)	<1 year	-20 to +35
	<6 months	-20 to +45
	<1 month	-20 to +55

TYPICAL CHARGE CHARACTERISTICS

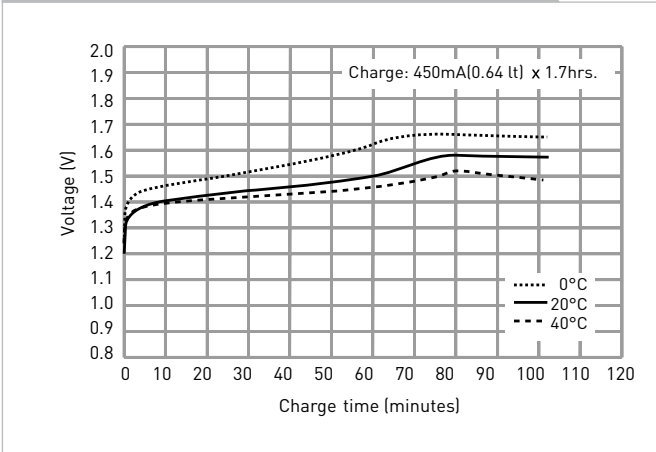

TYPICAL DISCHARGE CHARACTERISTICS

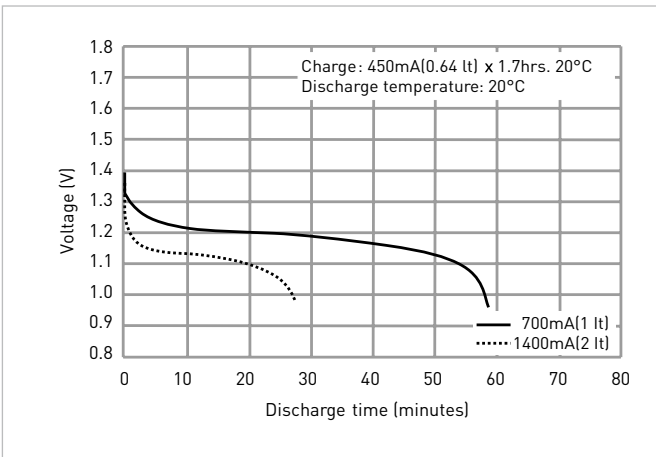
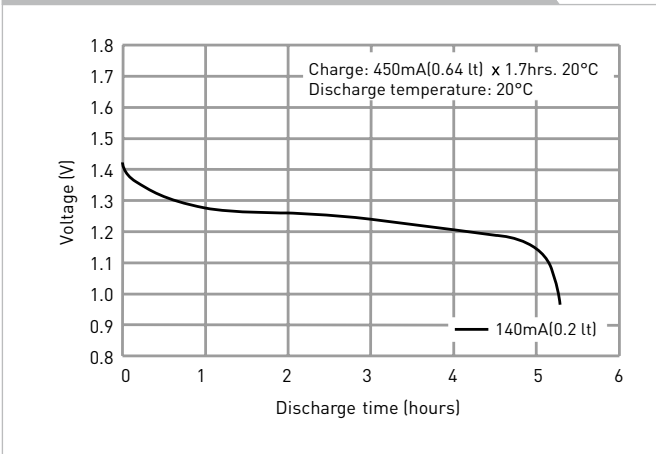

*1 After charging at 0.1It for 16 hours, discharging at 0.2It.
*2 For reference only.
*3 Need specially designed control system. Please contact Panasonic for details.

INDIVIDUAL DATA SHEETS

HHR-80AAA/HT CYLINDRICAL AAA SIZE (HR11/45)

DIMENSIONS (MM)

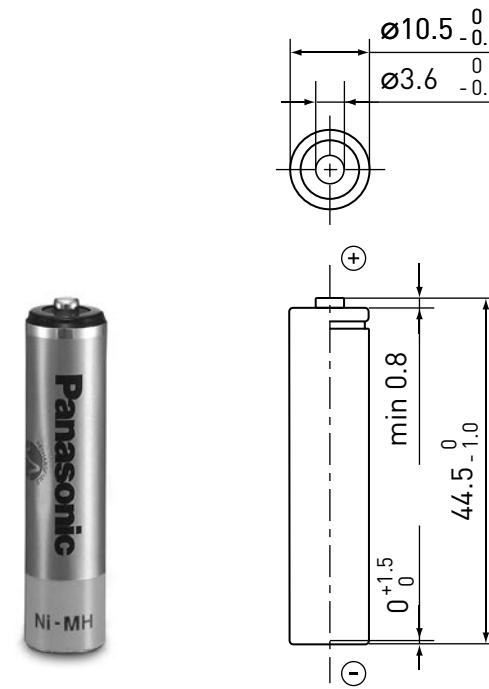

SPECIFICATIONS

Name	HHR-80AAA/HT	
Diameter (mm)	10.5 +0/-0.7	
Height (mm)	44.5 +0/-1.0	
Approximate weight (g)	13	
Nominal voltage (V)	1.2	
Discharge capacity*1	Average*2 (mAh)	780
	Rated/min. (mAh)	750
Approx. internal impedance at 1,000Hz at charged state (mΩ)	45	
Charge	Standard (mA x hrs.)	75 x 16
	Rapid*3 (mA x hrs.)	750 x 1.2
Ambient temperature	Charge (°C)	Standard: 0 to +45 Rapid: 0 to +40
	Discharge (°C)	-10 to +65
Storage (°C)	<1 year	-20 to +35
	<6 months	-20 to +45
	<1 month	-20 to +55

TYPICAL CHARGE CHARACTERISTICS

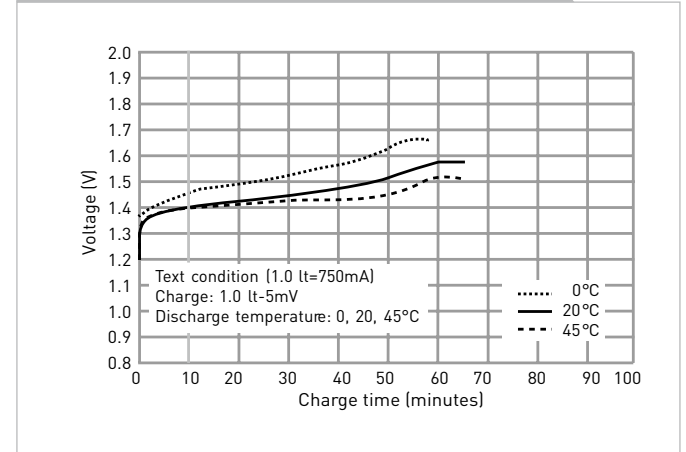

TYPICAL DISCHARGE CHARACTERISTICS

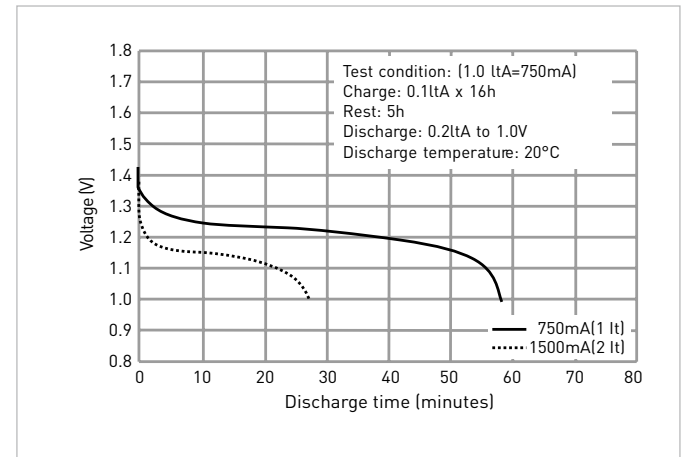
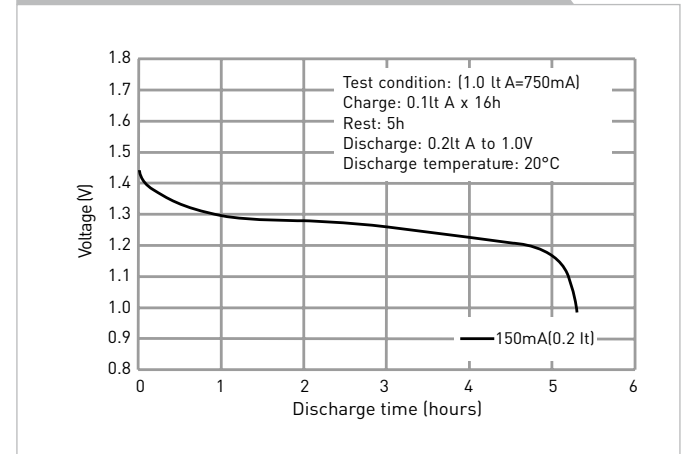

*1 After charging at 0.1It for 16 hours, discharging at 0.2It.
*2 For reference only.
*3 Need specially designed control system. Please contact Panasonic for details.

HHR-35AA/FT CYLINDRICAL 2/3AA SIZE

DIMENSIONS (MM)

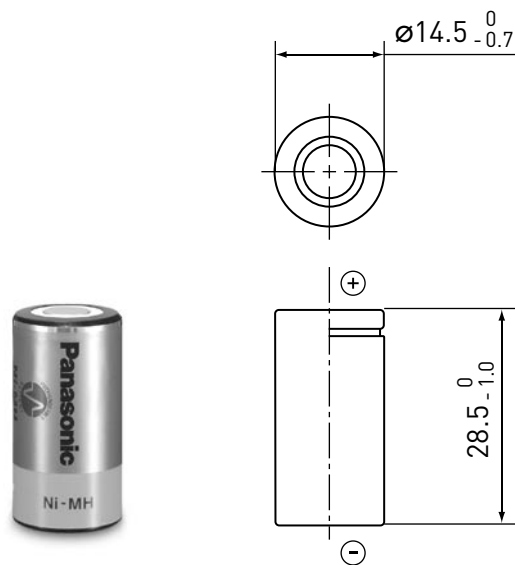

SPECIFICATIONS

Name	HHR-35AA/FT	
Diameter (mm)	14.5 +0/-0.7	
Height (mm)	28.5 +0/-1.0	
Approximate weight (g)	10,5	
Nominal voltage (V)	1.2	
Discharge capacity*1	Average*2 (mAh)	390
	Rated/min. (mAh)	350
Approx. internal impedance at 1,000Hz at charged state (mΩ)	30	
Charge	Standard (mA x hrs.)	35 x 16
	Rapid*3 (mA x hrs.)	350 x 1.2
Ambient temperature	Charge (°C)	Standard 0 to +45 Rapid 0 to +40
	Discharge (°C)	-10 to +65
Storage (°C)	<1 year	-20 to +35
	<6 months	-20 to +45
	<1 month	-20 to +55

*1 After charging at 0.1It for 16 hours, discharging at 0.2It.

*2 For reference only.

*3 Need specially designed control system. Please contact Panasonic for details.

TYPICAL CHARGE CHARACTERISTICS

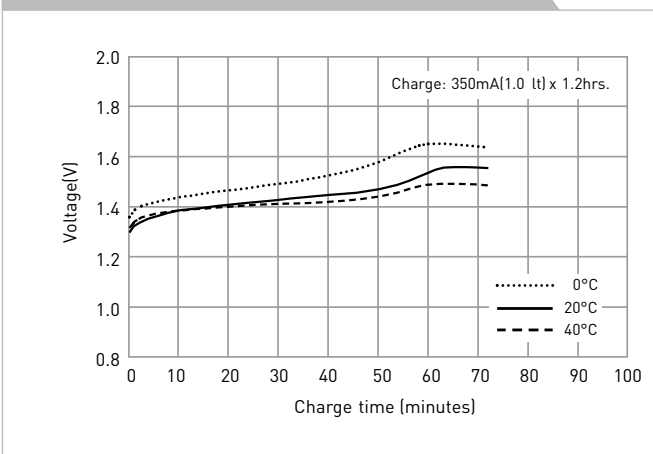

TYPICAL DISCHARGE CHARACTERISTICS

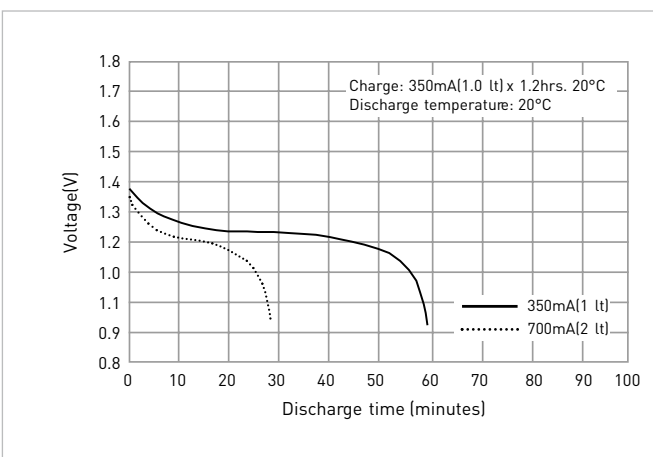
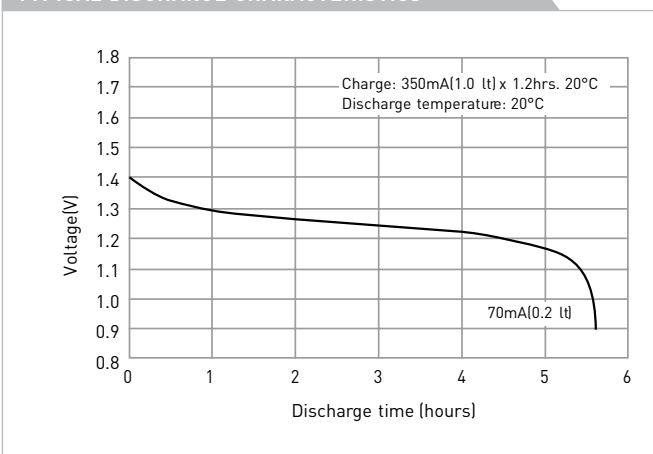

HHR-120AA/FT CYLINDRICAL 4/5AA SIZE (HR15/43)

DIMENSIONS (MM)

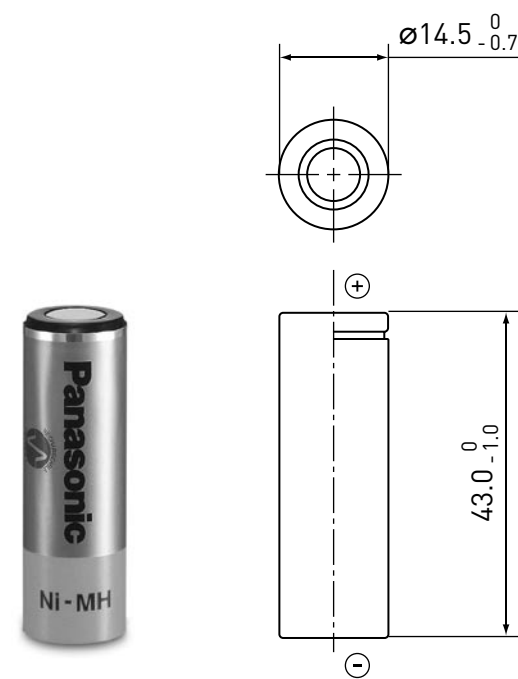

SPECIFICATIONS

Name	HHR-120AA/FT	
Diameter (mm)	14.5 +0/-0.7	
Height (mm)	43.0 +0/-1.0	
Approximate weight (g)	23	
Nominal voltage (V)	1.2	
Discharge capacity*1	Average*2 (mAh)	1,220
	Rated/min. (mAh)	1,150
Approx. internal impedance at 1,000Hz at charged state (mΩ)	19	
Charge	Standard (mA x hrs.)	120 x 16
	Rapid*3 (mA x hrs.)	1,200 x 1.2
Ambient temperature	Charge (°C)	Standard 0 to +45 Rapid 0 to +40
	Discharge (°C)	-10 to +65
Storage (°C)	<1 year	-20 to +35
	<6 months	-20 to +45
	<1 month	-20 to +55

*1 After charging at 0.1It for 16 hours, discharging at 0.2It.

*2 For reference only.

*3 Need specially designed control system. Please contact Panasonic for details.

TYPICAL CHARGE CHARACTERISTICS

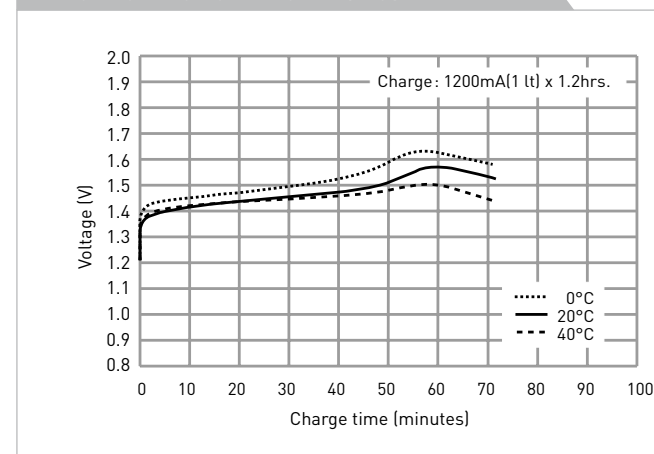

TYPICAL DISCHARGE CHARACTERISTICS

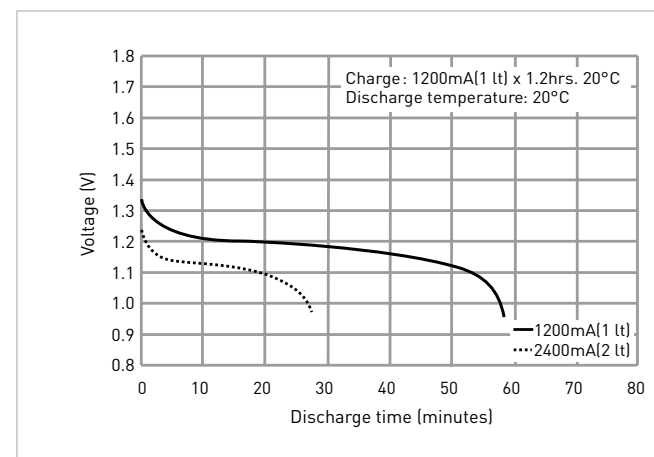
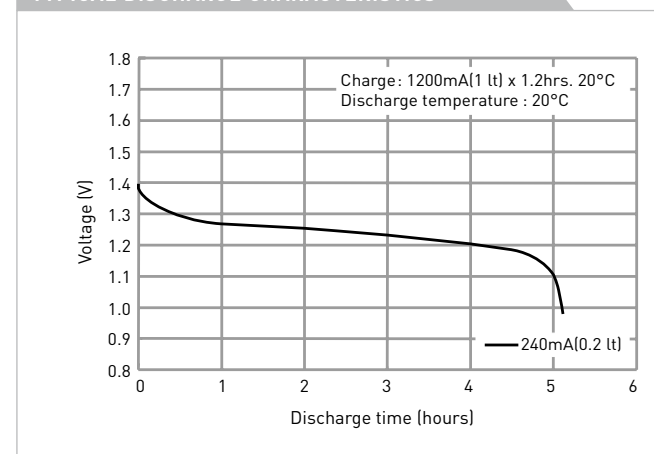

HHR-70AA/FT CYLINDRICAL AA SIZE (HR15/49)

DIMENSIONS (MM)

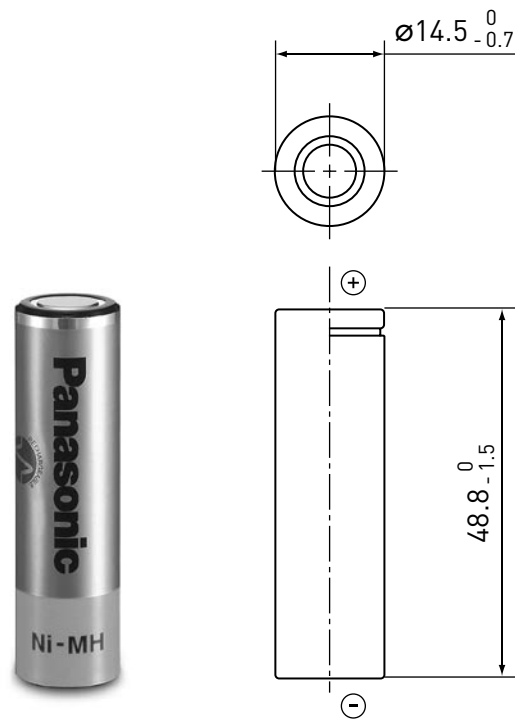

SPECIFICATIONS

Name	HHR-70AA/FT	
Diameter (mm)	14.5 +0/-0.7	
Height (mm)	48.8 +0/-1.5	
Approximate weight (g)	21	
Nominal voltage (V)	1.2	
Discharge capacity*1	Average*2 (mAh)	780
	Rated/min. (mAh)	700
Approx. internal impedance at 1,000Hz at charged state (mΩ)	25	
Charge	Standard (mA x hrs.)	70 x 16
	Rapid*3 (mA x hrs.)	700 x 1.2
Ambient temperature	Charge (°C)	Standard 0 to +45 Rapid 0 to +40
	Discharge (°C)	-10 to +65
Storage (°C)	<1 year	-20 to +35
	<6 months	-20 to +45
	<1 month	-20 to +55

*1 After charging at 0.1It for 16 hours, discharging at 0.2It.

*2 For reference only.

*3 Need specially designed control system. Please contact Panasonic for details.

TYPICAL CHARGE CHARACTERISTICS

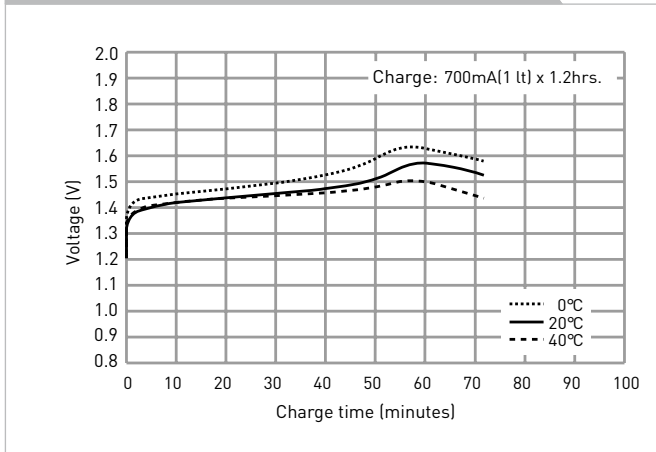

TYPICAL DISCHARGE CHARACTERISTICS

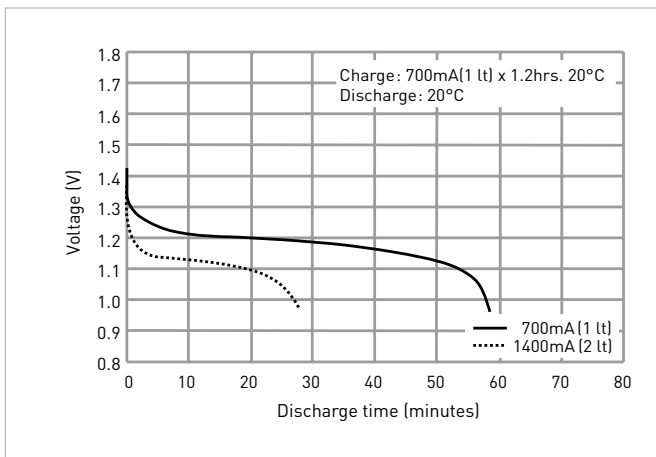
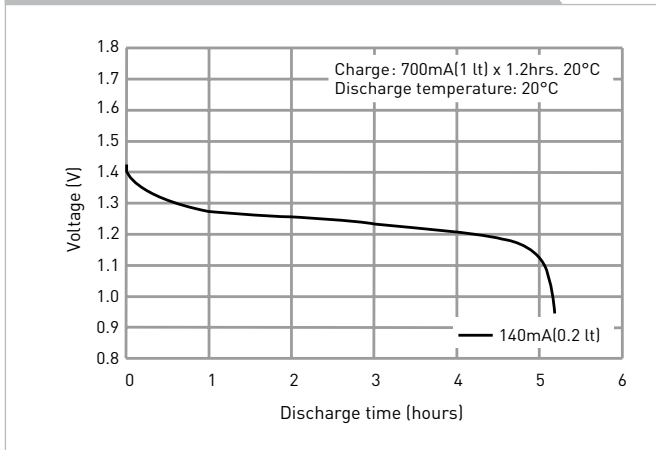

HHR-70AA/HT CYLINDRICAL AA SIZE (HR15/49)

DIMENSIONS (MM)

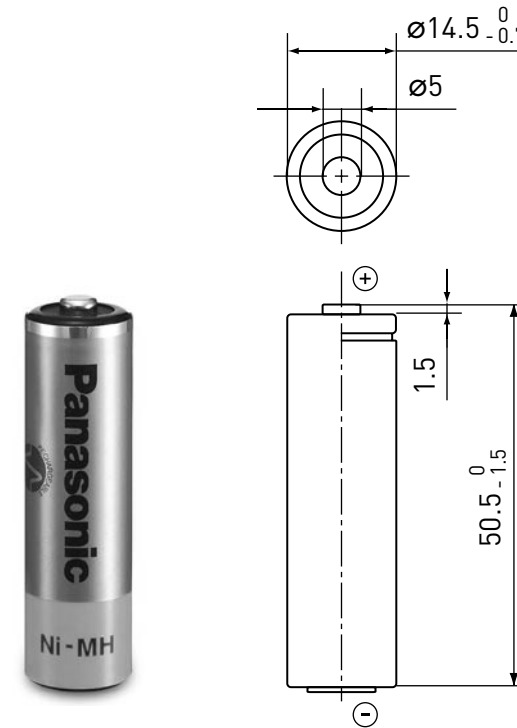

SPECIFICATIONS

Name	HHR-70AA/HT	
Diameter (mm)	14.5 +0/-0.7	
Height (mm)	50.5 +0/-1.5	
Approximate weight (g)	21	
Nominal voltage (V)	1.2	
Discharge capacity*1	Average*2 (mAh)	780
	Rated/min. (mAh)	700
Approx. internal impedance at 1,000Hz at charged state (mΩ)	25	
Charge	Standard (mA x hrs.)	70 x 16
	Rapid*3 (mA x hrs.)	700 x 1.2
Ambient temperature	Charge (°C)	Standard 0 to +45 Rapid 0 to +40
	Discharge (°C)	-10 to +65
Storage (°C)	<1 year	-20 to +35
	<6 months	-20 to +45
	<1 month	-20 to +55

*1 After charging at 0.1It for 16 hours, discharging at 0.2It.

*2 For reference only.

*3 Need specially designed control system. Please contact Panasonic for details.

TYPICAL CHARGE CHARACTERISTICS

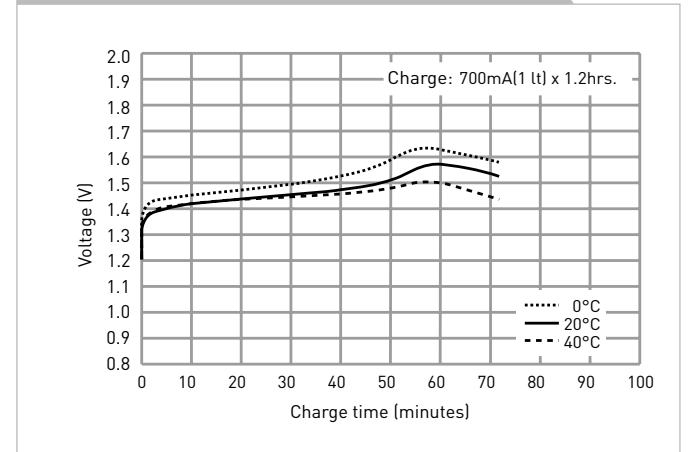

TYPICAL DISCHARGE CHARACTERISTICS

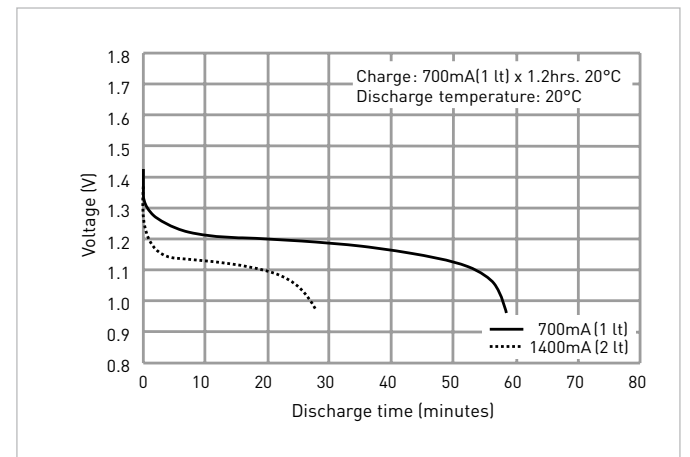
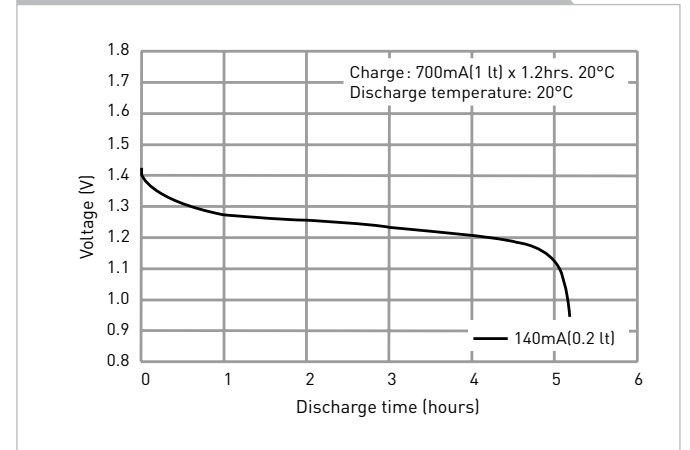

INDIVIDUAL DATA SHEETS

HHR-110AA/FT CYLINDRICAL AA SIZE (HR15/51)

DIMENSIONS (MM)

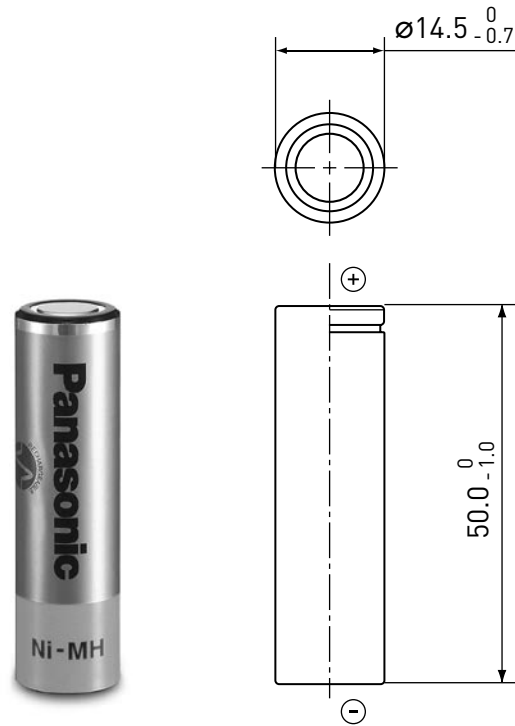

SPECIFICATIONS

Name	HHR-110AA/FT	
Diameter (mm)	14.5 +0/-0.7	
Height (mm)	50.0 +0/-1.0	
Approximate weight (g)	24	
Nominal voltage (V)	1.2	
Discharge capacity*1	Average*2 (mAh)	1,180
	Rated/min. (mAh)	1,100
Approx. internal impedance at 1,000Hz at charged state (mΩ)	16	
Charge	Standard (mA x hrs.)	110 x 16
	Rapid*3 (mA x hrs.)	1,100 x 1.2
Ambient temperature	Charge (°C)	Standard: 0 to +45 Rapid: 0 to +40
	Discharge (°C)	-10 to +65
Storage (°C)	<1 year	-20 to +35
	<3 months	-20 to +45
	<1 month	-20 to +55

TYPICAL CHARGE CHARACTERISTICS

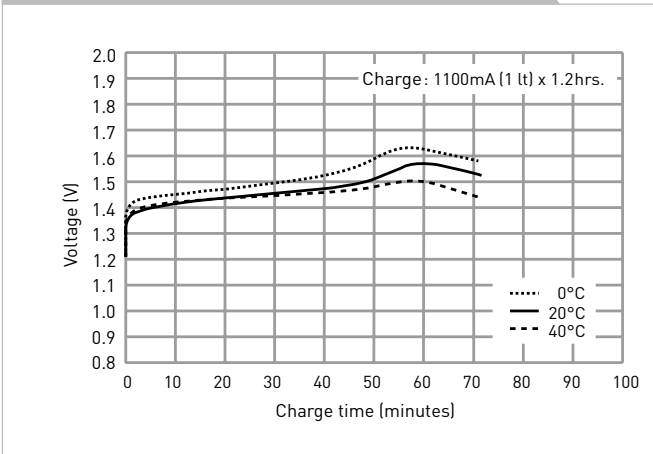

TYPICAL DISCHARGE CHARACTERISTICS

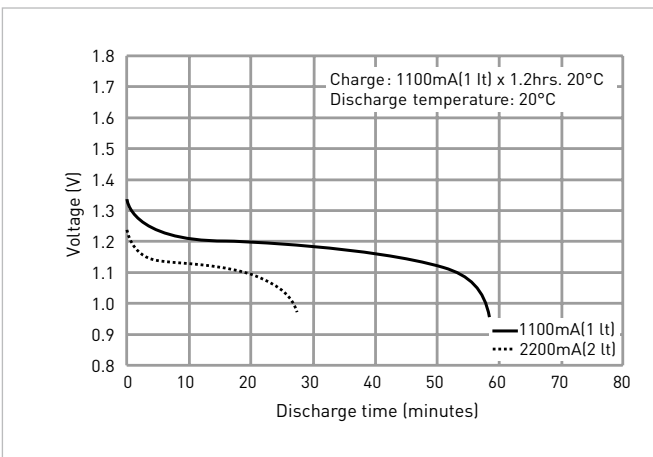
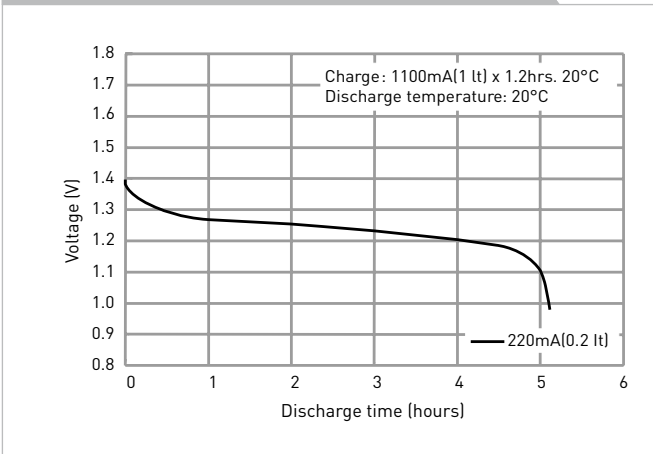

*1 After charging at 0.1It for 16 hours, discharging at 0.2It.
*2 For reference only.
*3 Need specially designed control system. Please contact Panasonic for details.

INDIVIDUAL DATA SHEETS

HHR-150AA/FT CYLINDRICAL AA SIZE (HR15/51)

DIMENSIONS (MM)

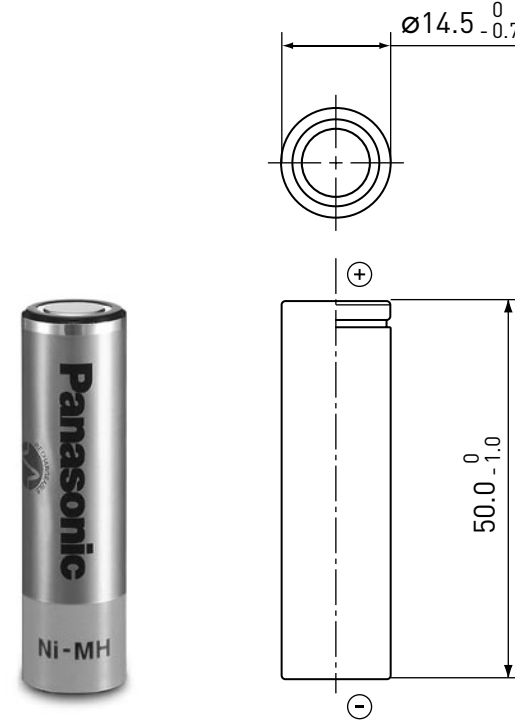

SPECIFICATIONS

Name	HHR-150AA/FT	
Diameter (mm)	14.5 +0/-0.7	
Height (mm)	50.5 +0/-1.0	
Approximate weight (g)	26	
Nominal voltage (V)	1.2	
Discharge capacity*1	Average*2 (mAh)	1,580
	Rated/min. (mAh)	1,500
Approx. internal impedance at 1,000Hz at charged state (mΩ)	23	
Charge	Standard (mA x hrs.)	150 x 16
	Rapid*3 (mA x hrs.)	1,500 x 1.2
Ambient temperature	Charge (°C)	Standard: 0 to +45 Rapid: 0 to +40
	Discharge (°C)	-10 to +65
Storage (°C)	<1 year	-20 to +35
	<3 months	-20 to +45
	<1 month	-20 to +55

TYPICAL CHARGE CHARACTERISTICS

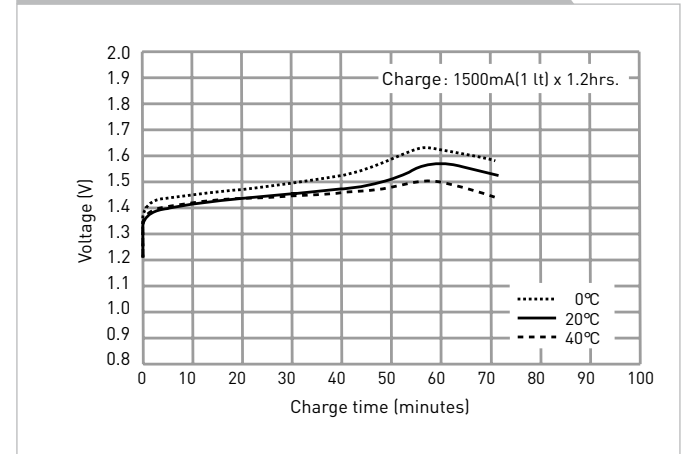

TYPICAL DISCHARGE CHARACTERISTICS

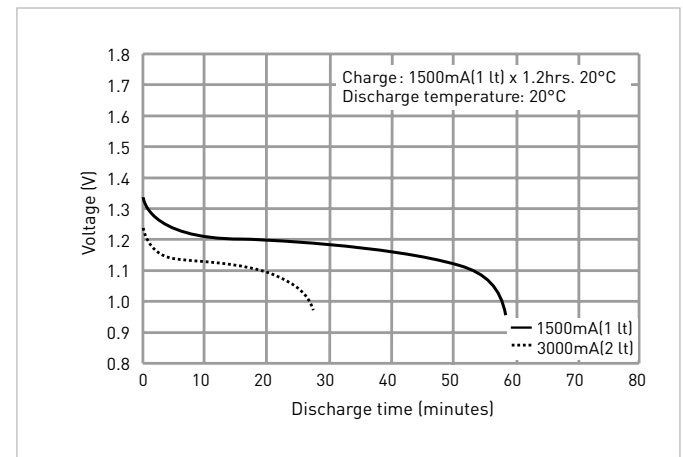
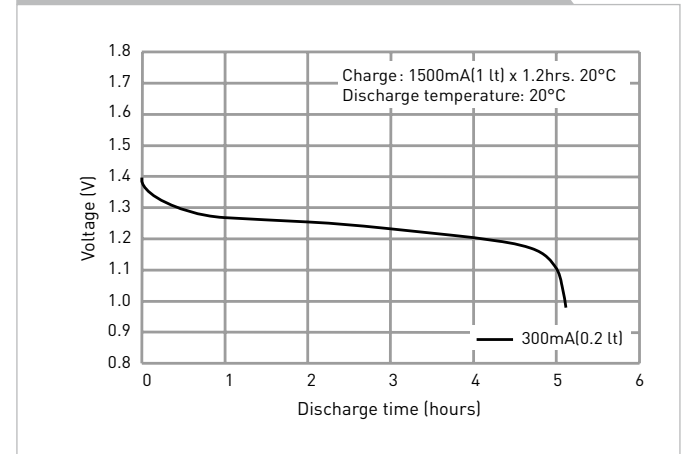

*1 After charging at 0.1It for 16 hours, discharging at 0.2It.
*2 For reference only.
*3 Need specially designed control system. Please contact Panasonic for details.

INDIVIDUAL DATA SHEETS

HHR-210AA/HT CYLINDRICAL AA SIZE (HR15/51)

DIMENSIONS (MM)

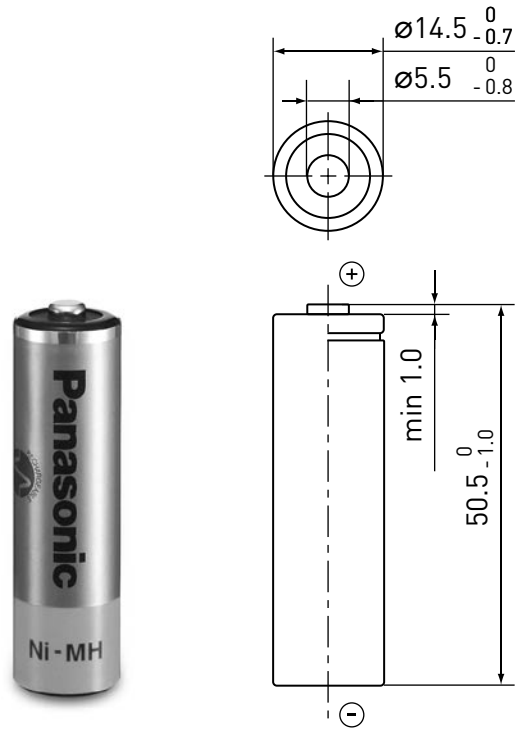

SPECIFICATIONS

Name		HHR-210AA/HT
Diameter (mm)		14.5 +0/-0.7
Height (mm)		50.5 +0/-1.0
Approximate weight (g)		29
Nominal voltage (V)		1.2
Discharge capacity*1	Average*2 (mAh)	2,080
	Rated/min. (mAh)	2,000
Approx. internal impedance at 1,000Hz at charged state (mΩ)		20
Charge	Standard (mA x hrs.)	200 x 16
	Rapid*3 (mA x hrs.)	1,200 x 2
Ambient temperature	Charge (°C)	Standard: 0 to +45 Rapid: 0 to +40
	Discharge (°C)	-10 to +65
Storage (°C)	<1 year	-20 to +35
	<3 months	-20 to +45
	<1 month	-20 to +55

*1 After charging at 0.1It for 16 hours, discharging at 0.2It.
*2 For reference only.
*3 Need specially designed control system. Please contact Panasonic for details.

TYPICAL CHARGE CHARACTERISTICS

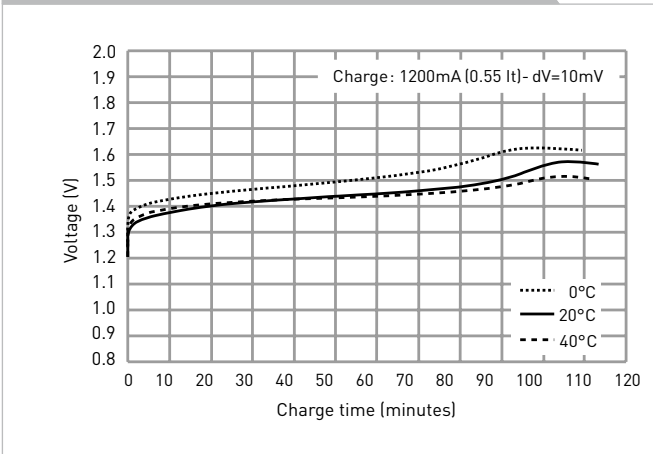

TYPICAL DISCHARGE CHARACTERISTICS

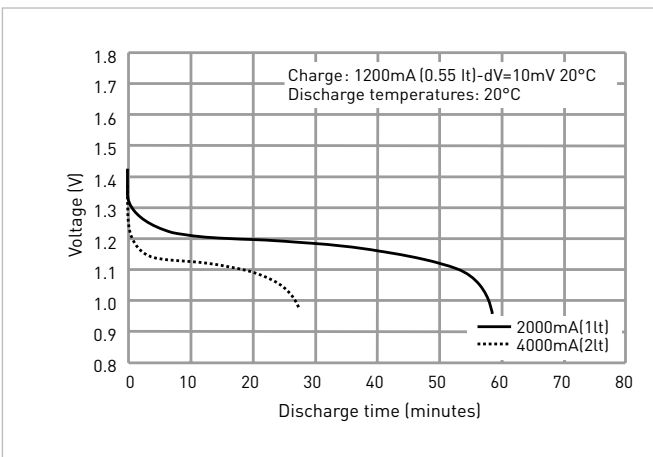
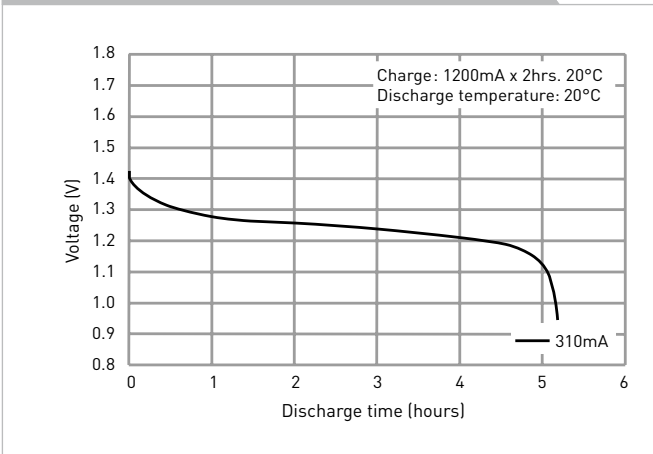

INDIVIDUAL DATA SHEETS

HHR-200A/FT CYLINDRICAL 4/5A SIZE (HR17/43)

DIMENSIONS (MM)

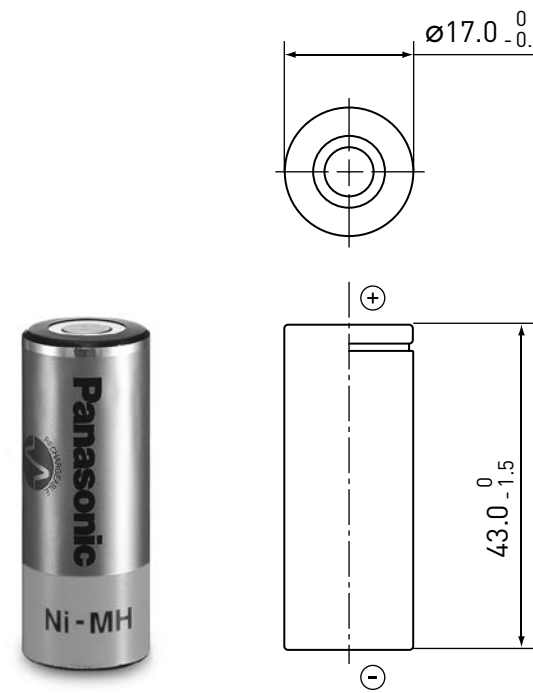

SPECIFICATIONS

Name		HHR-200A/FT
Diameter (mm)		17.0 +0/-0.7
Height (mm)		43.0 +0/-1.5
Approximate weight (g)		32
Nominal voltage (V)		1.2
Discharge capacity*1	Average*2 (mAh)	2,040
	Rated/min. (mAh)	2,000
Approx. internal impedance at 1,000Hz at charged state (mΩ)		20
Charge	Standard (mA x hrs.)	200 x 16
	Rapid*3 (mA x hrs.)	1,700 x 1.4
Ambient temperature	Charge (°C)	Standard: 0 to +45 Rapid: 0 to +40
	Discharge (°C)	-10 to +65
Storage (°C)	<1 year	-20 to +35
	<3 months	-20 to +45
	<1 month	-20 to +55

*1 After charging at 0.1It for 16 hours, discharging at 0.2It.
*2 For reference only.
*3 Need specially designed control system. Please contact Panasonic for details.

INDIVIDUAL DATA SHEETS

HHR-210A/FT CYLINDRICAL A SIZE (HR17/50)

DIMENSIONS (MM)

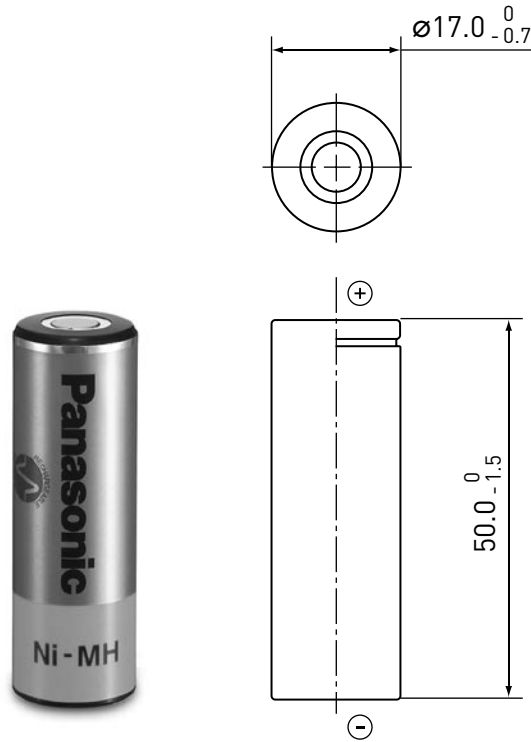

SPECIFICATIONS

Name		HHR-210A/FT
Diameter (mm)		17.0 +0/-0.7
Height (mm)		50.0 +0/-1.5
Approximate weight (g)		38
Nominal voltage (V)		1.2
Discharge capacity*1	Average*2 (mAh)	2,200
	Rated/min. (mAh)	2,100
Approx. internal impedance at 1,000Hz at charged state (mΩ)		20
Charge	Standard (mA x hrs.)	210 x 16
	Rapid*3 (mA x hrs.)	2,100 x 1.2
Ambient temperature	Charge (°C)	Standard: 0 to +45 Rapid: 0 to +40
	Discharge (°C)	-10 to +65
Storage (°C)	<1 year	-20 to +35
	<3 months	-20 to +45
	<1 month	-20 to +55

*1 After charging at 0.1It for 16 hours, discharging at 0.2It.
 *2 For reference only.
 *3 Need specially designed control system. Please contact Panasonic for details.

TYPICAL CHARGE CHARACTERISTICS

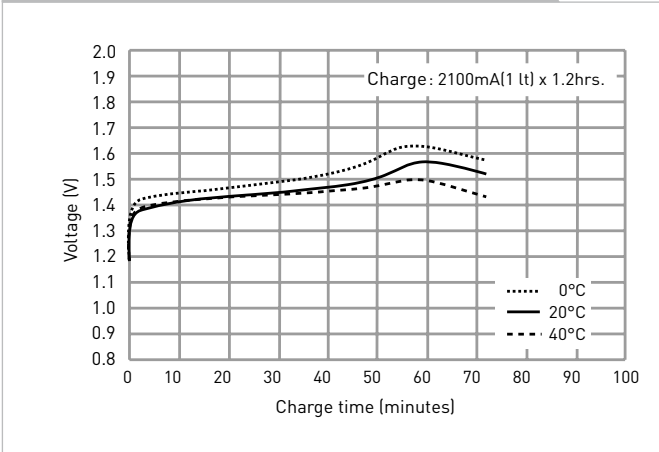

TYPICAL DISCHARGE CHARACTERISTICS

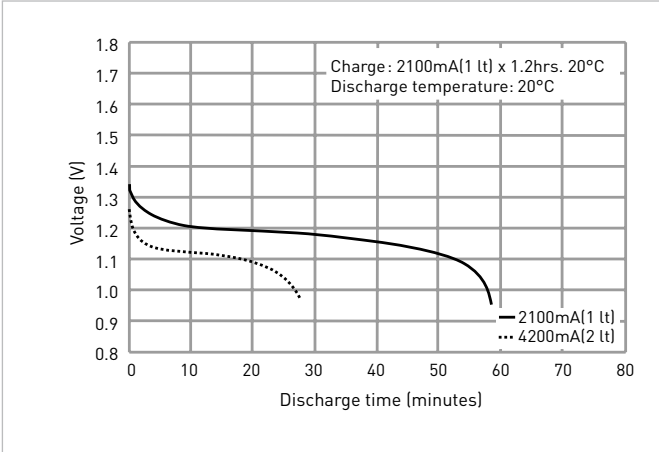
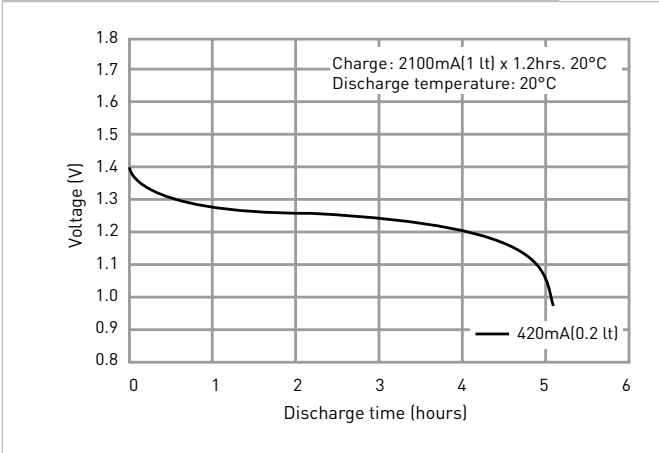

INDIVIDUAL DATA SHEETS

HHR-380A/FT

DIMENSIONS (MM)

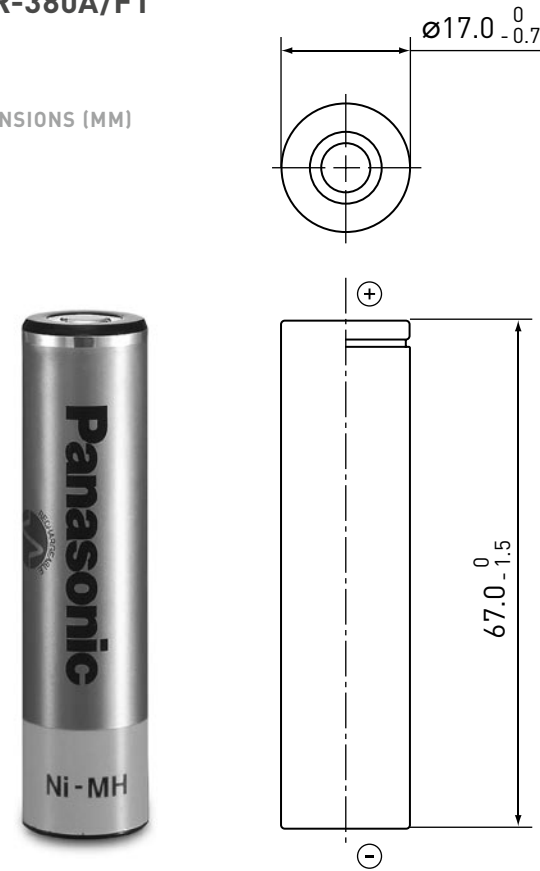

SPECIFICATIONS

Name		HHR-380A/FT
Diameter (mm)		17.0 +0/-0.7
Height (mm)		67.0 +0/-1.5
Approximate weight (g)		53
Nominal voltage (V)		1.2
Discharge capacity*1	Average*2 (mAh)	3,800
	Rated/min. (mAh)	3,700
Approx. internal impedance at 1,000Hz at charged state (mΩ)		25
Charge	Standard (mA x hrs.)	370 x 16
	Rapid*3 (mA dT/dt)	2,000 x 1.2
Ambient temperature	Charge (°C)	Standard: 0 to +45 Rapid: 0 to +40
	Discharge (°C)	-10 to +65
Storage (°C)	<1 year	-20 to +35
	<3 months	-20 to +45
	<1 month	-20 to +55

*1 After charging at 0.1It for 16 hours, discharging at 0.2It.
 *2 For reference only.
 *3 Need specially designed control system. Please contact Panasonic for details.

CYLINDRICAL L-A SIZE (HR17/67)

TYPICAL CHARGE CHARACTERISTICS

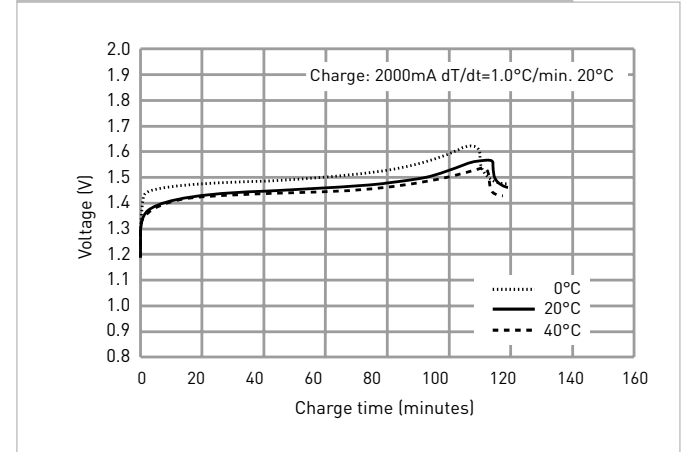

TYPICAL DISCHARGE CHARACTERISTICS

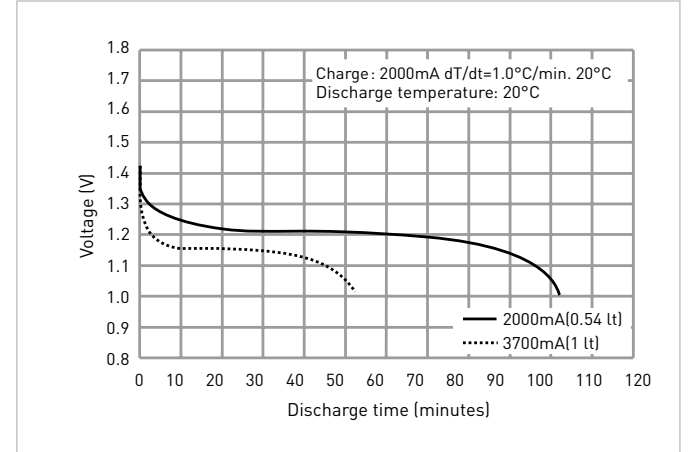
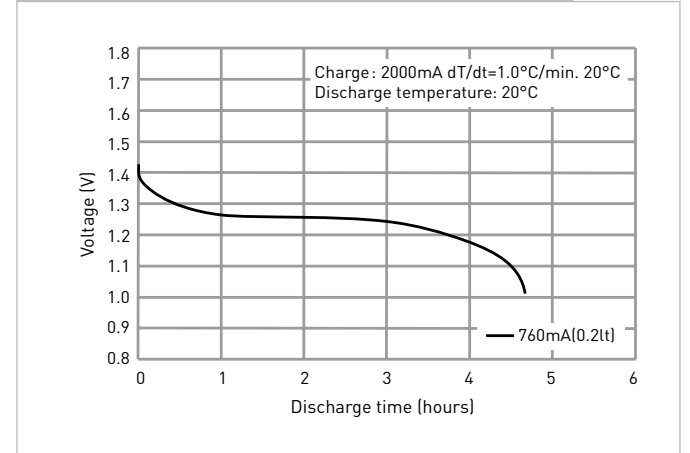

INDIVIDUAL DATA SHEETS

HHR-450A/FT

DIMENSIONS (MM)

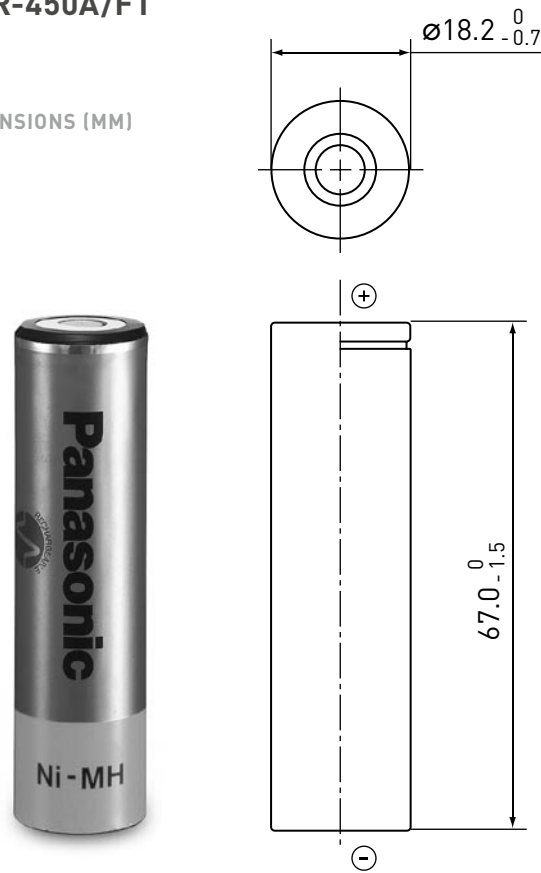

CYLINDRICAL LFAT/A SIZE

TYPICAL CHARGE CHARACTERISTICS

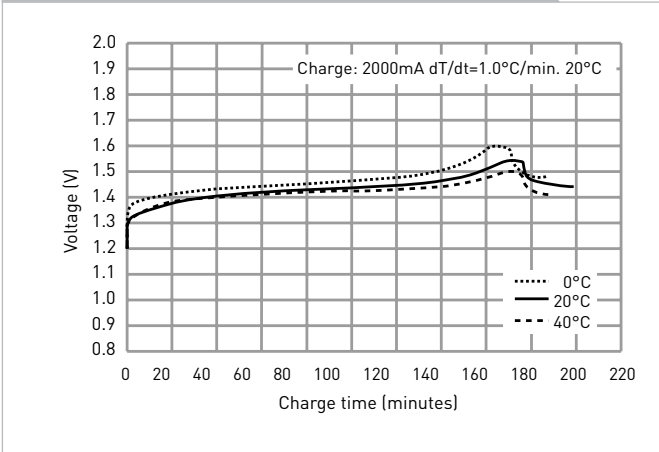

TYPICAL DISCHARGE CHARACTERISTICS

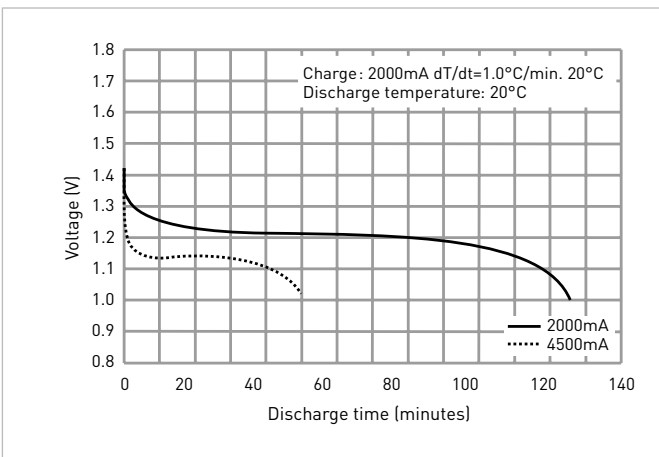
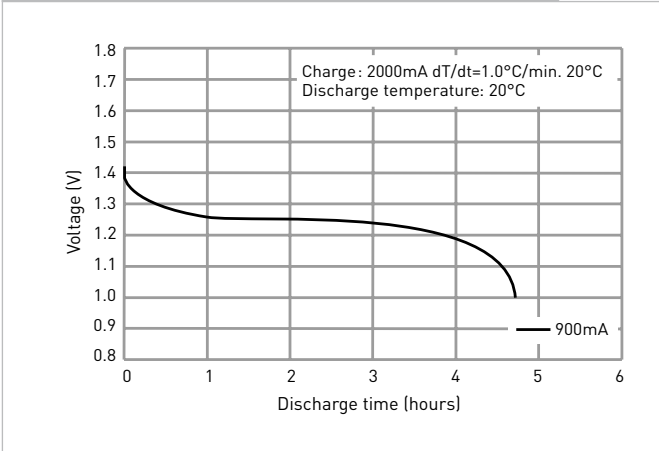

SPECIFICATIONS

Name		HHR-450A/FT
Diameter (mm)		18.2 +0/-0.7
Height (mm)		67.0 +0/-1.5
Approximate weight (g)		60
Nominal voltage (V)		1.2
Discharge capacity*1	Average*2 (mAh)	4,500
	Rated/min. (mAh)	4,200
Approx. internal impedance at 1,000Hz at charged state (mΩ)		25
Charge	Standard (mA x hrs.)	450 x 16
	Rapid*3 (mA dT/dt)	2,000 x 1.2
Ambient temperature	Charge (°C)	Standard: 0 to +45 Rapid: 0 to +40
	Discharge (°C)	-10 to +65
Storage (°C)	<1 year	-20 to +35
	<3 months	-20 to +45
	<1 month	-20 to +55

*1 After charging at 0.1It for 16 hours, discharging at 0.2It.

*2 For reference only.

*3 Need specially designed control system. Please contact Panasonic for details.

Battery performance and cycle life are strongly affected by how they are used. In order to maximize battery safety, please consult Panasonic when determining charge/discharge specs, warning label contents and design. The data in this document are for descriptive purposes only and are not intended to make or imply any guarantee or warranty.

INDIVIDUAL DATA SHEETS

HHR-200SCP/FT CYLINDRICAL 4/5 SC SIZE

DIMENSIONS (MM)

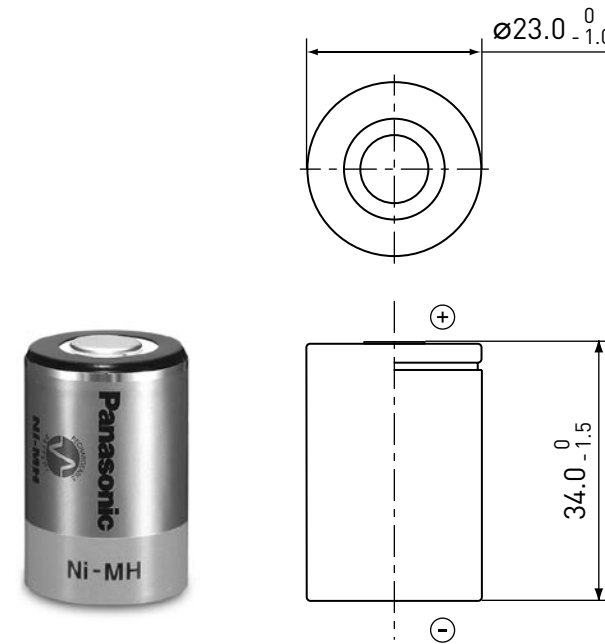

SPECIFICATIONS

Name		HHR-200SCP/FT
Diameter (mm)		23.0 +0/-1.0
Height (mm)		34.0 +0/-1.5
Approximate weight (g)		43
Nominal voltage (V)		1.2
Discharge capacity*1	Average*2 (mAh)	2,100
	Rated/min. (mAh)	1,900
Approx. internal impedance at 1,000Hz at charged state (mΩ)		5
Charge	Standard (mA x hrs.)	200 x 16
	Rapid*3 (mA x hrs.)	2,000 x 1.2
Ambient temperature	Charge (°C)	Standard: 0 to +45 Rapid: 0 to +40
	Discharge (°C)	-10 to +65
Storage (°C)	<1 year	-20 to +35
	<3 months	-20 to +45
	<1 month	-20 to +55

*1 After charging at 0.1It for 16 hours, discharging at 0.2It.

*2 For reference only.

*3 Need specially designed control system. Please contact Panasonic for details.

Battery performance and cycle life are strongly affected by how they are used. In order to maximize battery safety, please consult Panasonic when determining charge/discharge specs, warning label contents and design. The data in this document are for descriptive purposes only and are not intended to make or imply any guarantee or warranty.

HHR-260SCP/FT CYLINDRICAL SC SIZE (HR23/43)

DIMENSIONS (MM)

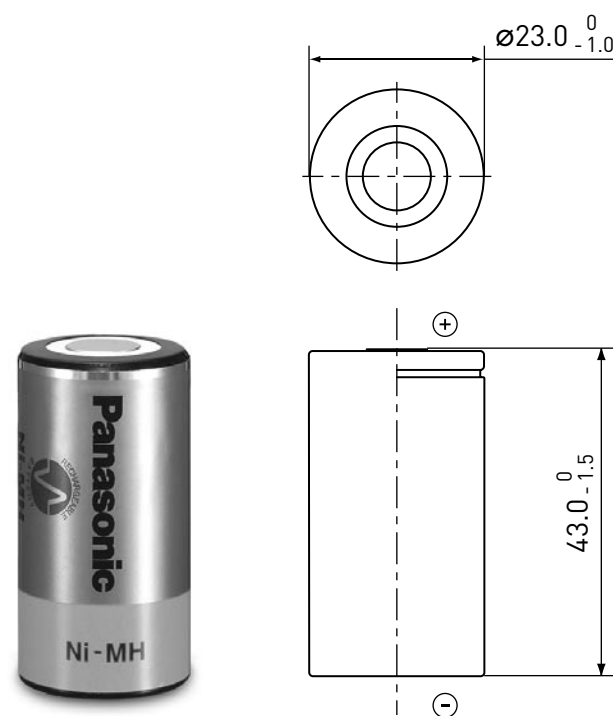

SPECIFICATIONS

Name		HHR-260SCP/FT
Diameter (mm)		23.0 +0/-1.0
Height (mm)		43.0 +0/-1.5
Approximate weight (g)		55
Nominal voltage (V)		1.2
Discharge capacity*1	Average*2 (mAh)	2,600
	Rated/min. (mAh)	2,450
Approx. internal impedance at 1,000Hz at charged state (mΩ)		5
Charge	Standard (mA x hrs.)	260 x 16
	Rapid*3 (mA x hrs.)	2,600 x 1.2
Ambient temperature	Charge (°C)	Standard: 0 to +45 Rapid: 0 to +40
	Discharge (°C)	-10 to +65
Storage (°C)	<1 year	-20 to +35
	<3 months	-20 to +45
	<1 month	-20 to +55

*1 After charging at 0.1It for 16 hours, discharging at 0.2It.

*2 For reference only.

*3 Need specially designed control system. Please contact Panasonic for details.

TYPICAL CHARGE CHARACTERISTICS

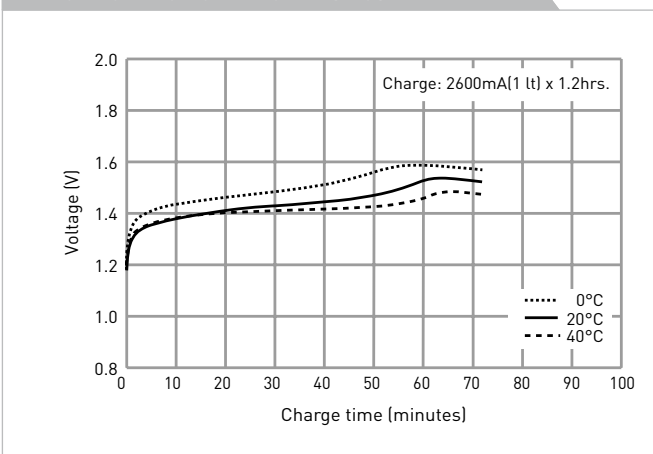

TYPICAL DISCHARGE CHARACTERISTICS

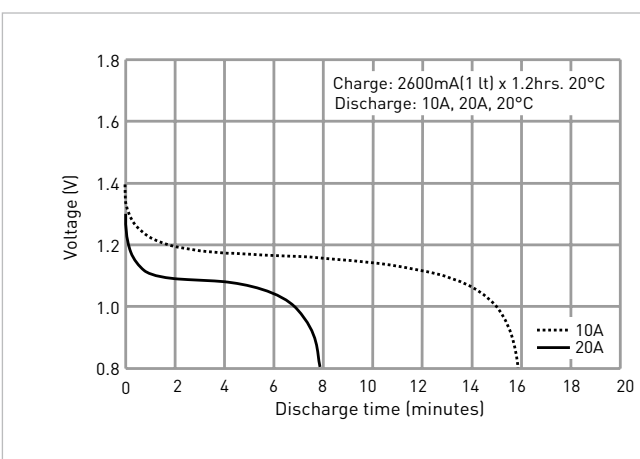
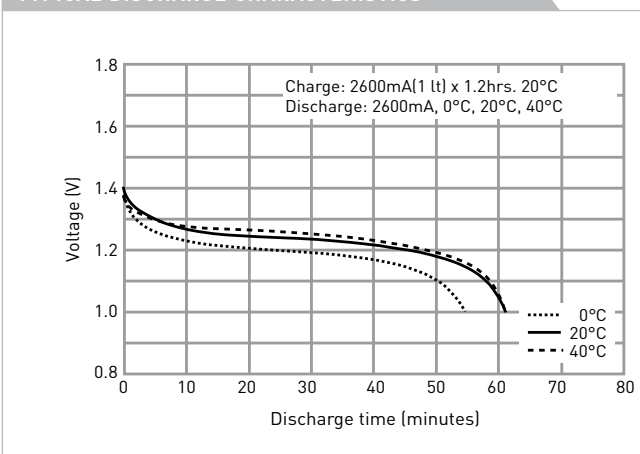

HHR-300SCP/FT CYLINDRICAL SC SIZE (HR23/43)

DIMENSIONS (MM)

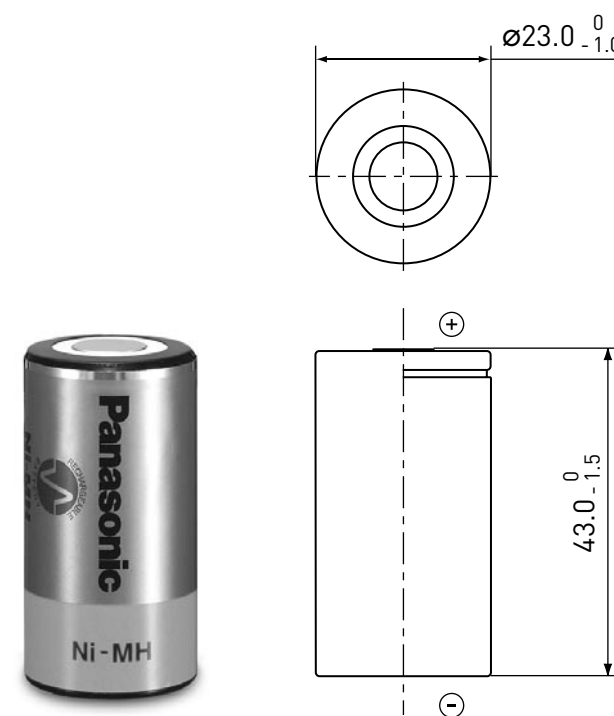

SPECIFICATIONS

Name		HHR-300SCP/FT
Diameter (mm)		23.0 +0/-1.0
Height (mm)		43.0 +0/-1.5
Approximate weight (g)		57
Nominal voltage (V)		1.2
Discharge capacity*1	Average*2 (mAh)	3,050
	Rated/min. (mAh)	2,800
Approx. internal impedance at 1,000Hz at charged state (mΩ)		4
Charge	Standard (mA x hrs.)	300 x 16
	Rapid*3 (mA x hrs.)	3,000 x 1.2
Ambient temperature	Charge (°C)	Standard: 0 to +45 Rapid: 0 to +40
	Discharge (°C)	-10 to +65
Storage (°C)	<1 year	-20 to +35
	<3 months	-20 to +45
	<1 month	-20 to +55

*1 After charging at 0.1It for 16 hours, discharging at 0.2It.

*2 For reference only.

*3 Need specially designed control system. Please contact Panasonic for details.

TYPICAL CHARGE CHARACTERISTICS

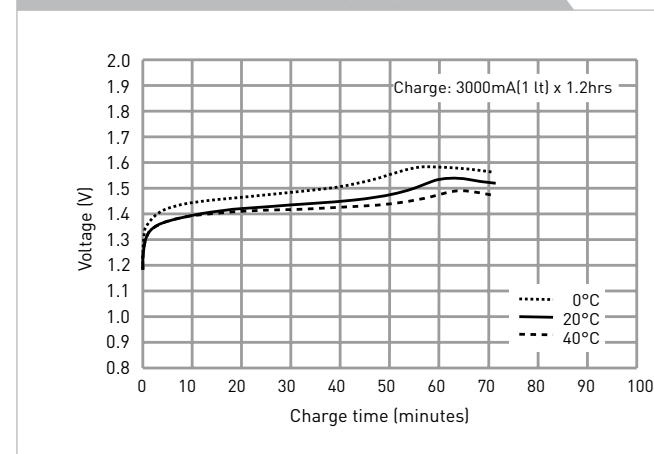

TYPICAL DISCHARGE CHARACTERISTICS

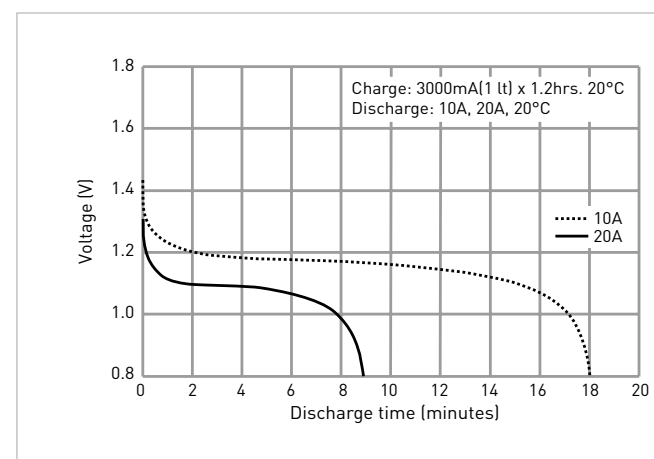
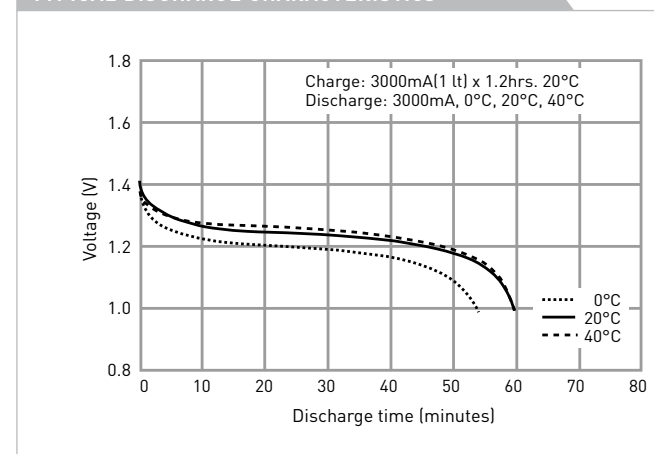

HHR-60AAAH/FT CYLINDRICAL AAA SIZE (HR11/45) FOR BACK-UP USE

DIMENSIONS (MM)

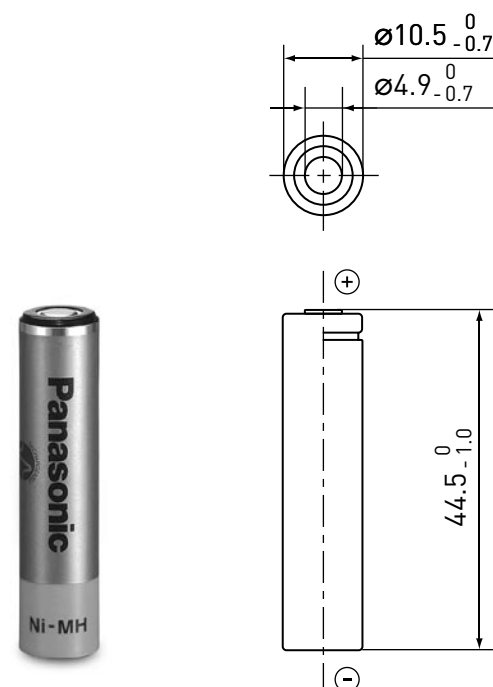

SPECIFICATIONS

Name		HHR-60AAAH/FT
Diameter (mm)		10.5 +0/-0.7
Height (mm)		44.5 +0/-1.0
Approximate weight (g)		13
Nominal voltage (V)		1.2
Discharge capacity*1	Average*2 (mAh)	550
	Rated/min. (mAh)	500
Approx. internal impedance at 1,000Hz at charged state (mΩ)		35
Charge	Standard (mA x hrs.)	50 x 16
	Rapid*3 (mA x hrs.)	250 x 2.4
	Low rate (mA x hrs.)	25 x 32
		17 x 48
Charge (°C)	Standard	-10 to +60
	Rapid	-10 to +45
	Low rate	-10 to +45
Discharge (°C)		-10 to +60
Ambient temperature Storage (°C)	<1 year	-20 to +35
	<6 months	-20 to +45
	<1 month	-20 to +55
	<1 week	-20 to +65

TYPICAL CHARGE CHARACTERISTICS

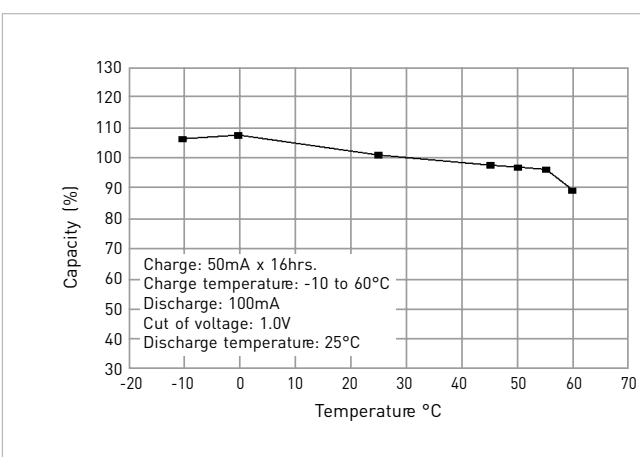
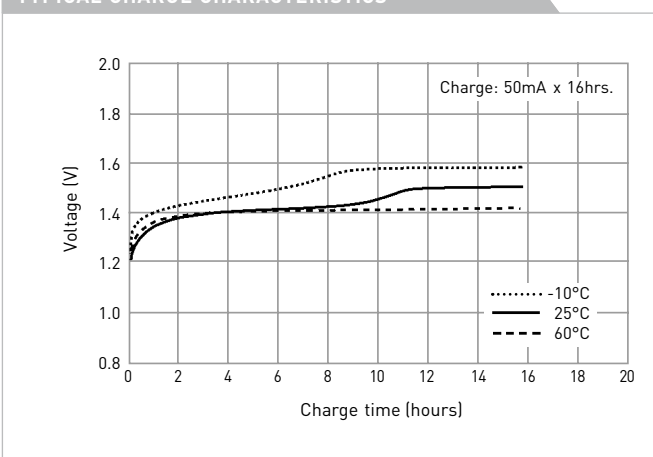

TYPICAL DISCHARGE CHARACTERISTICS

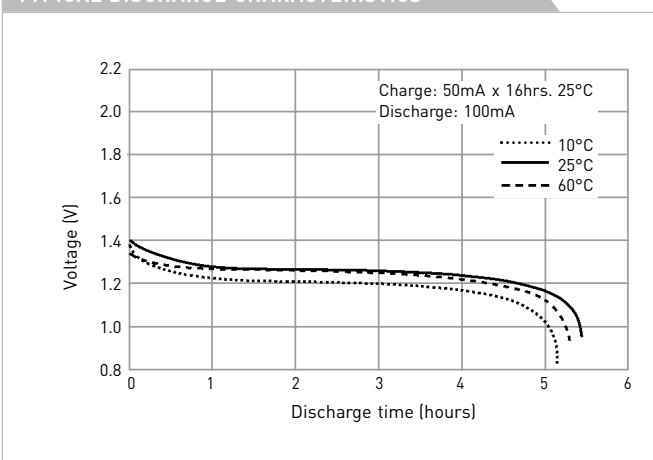

*1 After charging at 0.1It for 16 hours, discharging at 0.2It.

*2 For reference only.

*3 Need specially designed control system. Please contact Panasonic for details.

Battery performance and cycle life are strongly affected by how they are used. In order to maximize battery safety, please consult Panasonic when determining charge/discharge specs, warning label contents and design. The data in this document are for descriptive purposes only and are not intended to make or imply any guarantee or warranty.

HHR-70AAH/FT CYLINDRICAL AA SIZE (HR15/49) FOR BACK-UP USE

DIMENSIONS (MM)

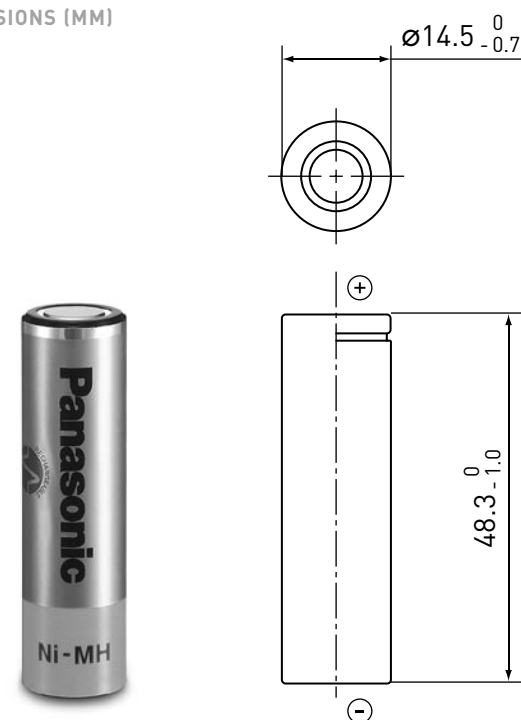

SPECIFICATIONS

Name		HHR-70AAH/FT
Diameter (mm)		14.5 +0/-0.7
Height (mm)		48.3 +0/-1.0
Approximate weight (g)		18
Nominal voltage (V)		1.2
Discharge capacity*1	Average*2 (mAh)	750
	Rated/min. (mAh)	700
Approx. internal impedance at 1,000Hz at charged state (mΩ)		25
Charge	Standard (mA x hrs.)	70 x 16
	Rapid*3 (mA x hrs.)	350 x 2.4
	Low rate (mA x hrs.)	35 x 32
		23 x 48
Charge (°C)	Standard	-10 to +60
	Rapid	-10 to +45
	Low rate	-10 to +45
Discharge (°C)		-10 to +60
Ambient temperature Storage (°C)	<1 year	-20 to +35
	<6 months	+35 to +45
	<1 month	+45 to +55
	<1 week	+55 to +65

TYPICAL CHARGE CHARACTERISTICS

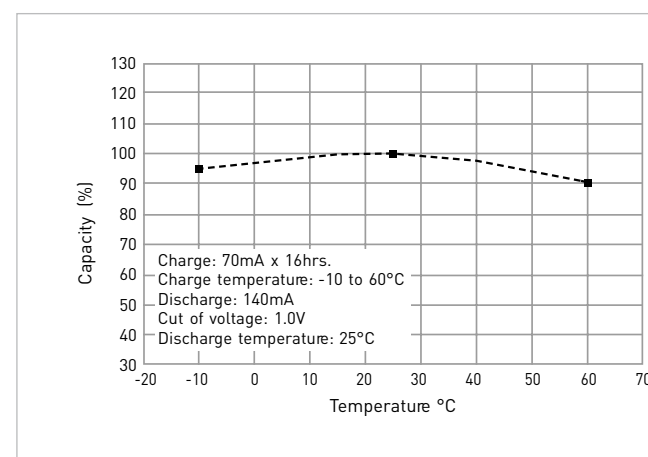
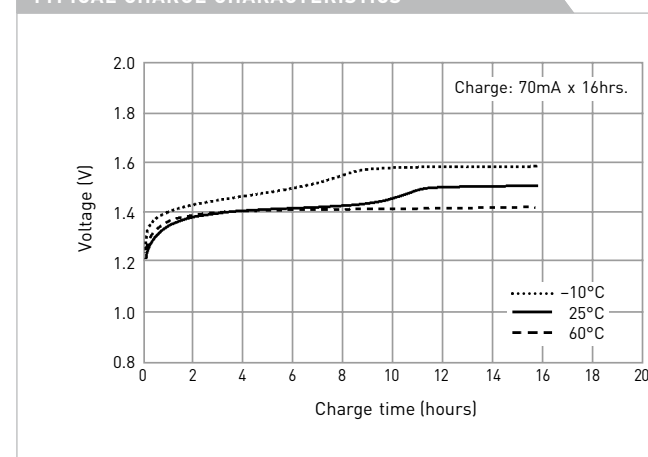

TYPICAL DISCHARGE CHARACTERISTICS

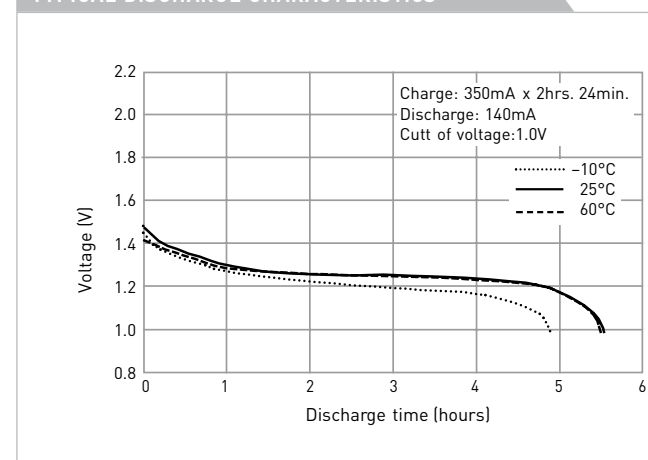

*1 After charging at 0.1It for 16 hours, discharging at 0.2It.

*2 For reference only.

*3 Need specially designed control system. Please contact Panasonic for details.

Battery performance and cycle life are strongly affected by how they are used. In order to maximize battery safety, please consult Panasonic when determining charge/discharge specs, warning label contents and design. The data in this document are for descriptive purposes only and are not intended to make or imply any guarantee or warranty.

HHR-210AH/FT CYLINDRICAL A SIZE (HR17/50) FOR BACK-UP USE

DIMENSIONS (MM)

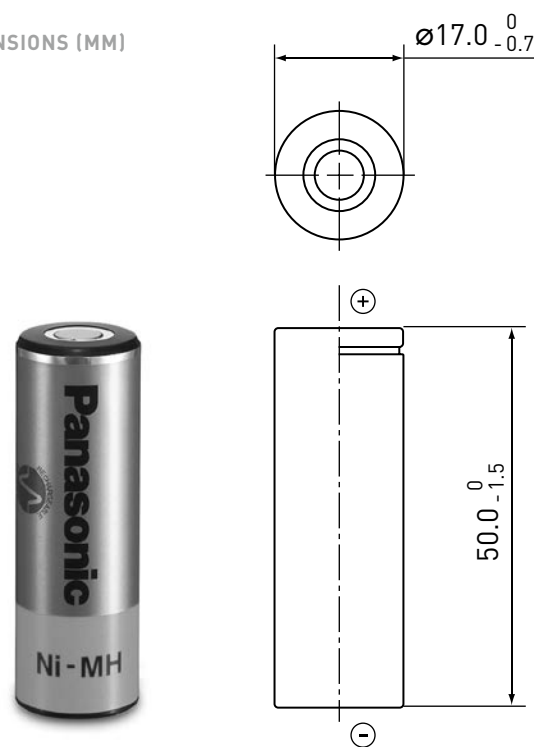

SPECIFICATIONS

Name		HHR-210AH/FT	
Diameter (mm)		17.0 +0/-0.7	
Height (mm)		50.0 +0/-1.5	
Approximate weight (g)		36	
Nominal voltage (V)		1.2	
Discharge capacity*1	Average*2 (mAh)	2,050	
	Rated/min. (mAh)	1,900	
Approx. internal impedance at 1,000Hz at charged state (mΩ)		20	
Charge	Standard (mA x hrs.)	210 x 16	
	Rapid*3 (mA x hrs.)	1,000 x 2.3	
	Low rate (mA x hrs.)	105 x 32	
		70 x 48	
Ambient temperature	Charge (°C)	Standard	-10 to +60
		Rapid	-10 to +45
		Low rate	-10 to +45
Discharge (°C)	Standard	-10 to +60	
	Rapid	-10 to +45	
	Low rate	-10 to +45	
Storage (°C)	<1 year	-20 to +35	
	<6 months	-20 to +45	
	<1 month	-20 to +55	
	<1 week	-20 to +65	

TYPICAL CHARGE CHARACTERISTICS

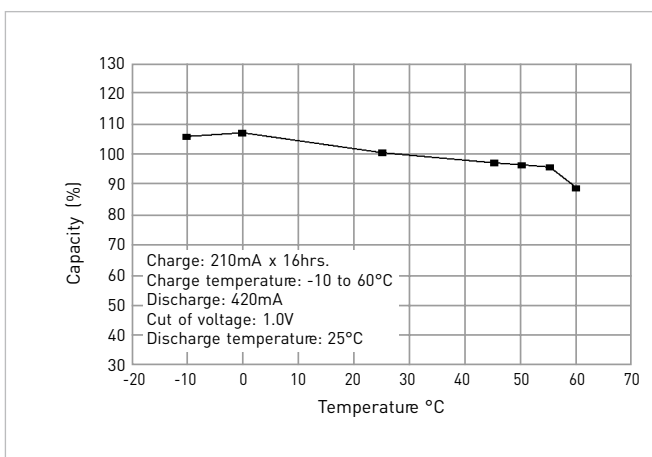
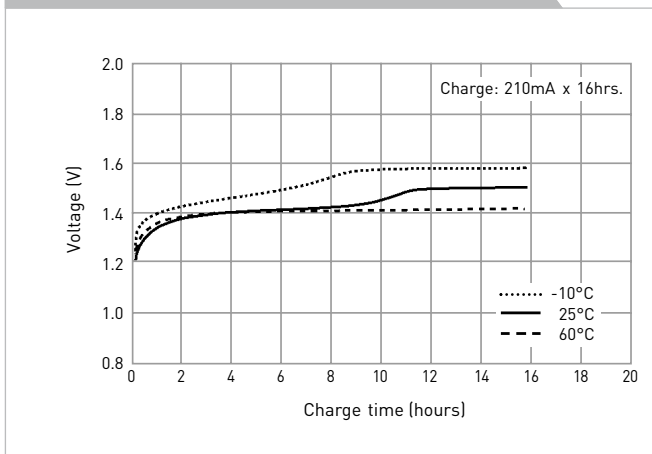

TYPICAL DISCHARGE CHARACTERISTICS

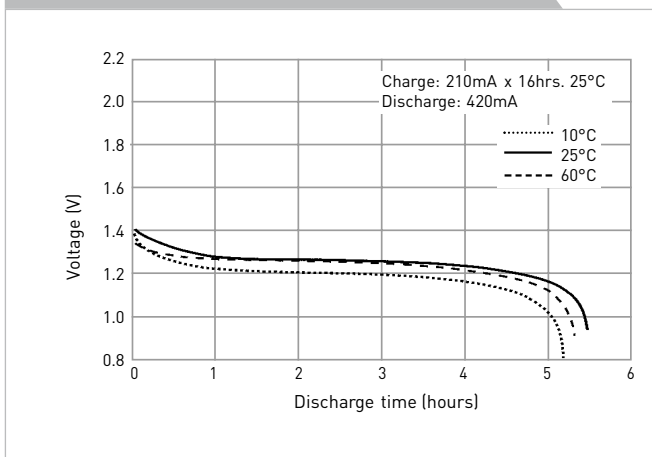

*1 After charging at 0.1It for 16 hours, discharging at 0.2It.

*2 For reference only.

*3 Need specially designed control system. Please contact Panasonic for details.

Battery performance and cycle life are strongly affected by how they are used. In order to maximize battery safety, please consult Panasonic when determining charge/discharge specs, warning label contents and design. The data in this document are for descriptive purposes only and are not intended to make or imply any guarantee or warranty.

HHR-330APH/FT

DIMENSIONS (MM)

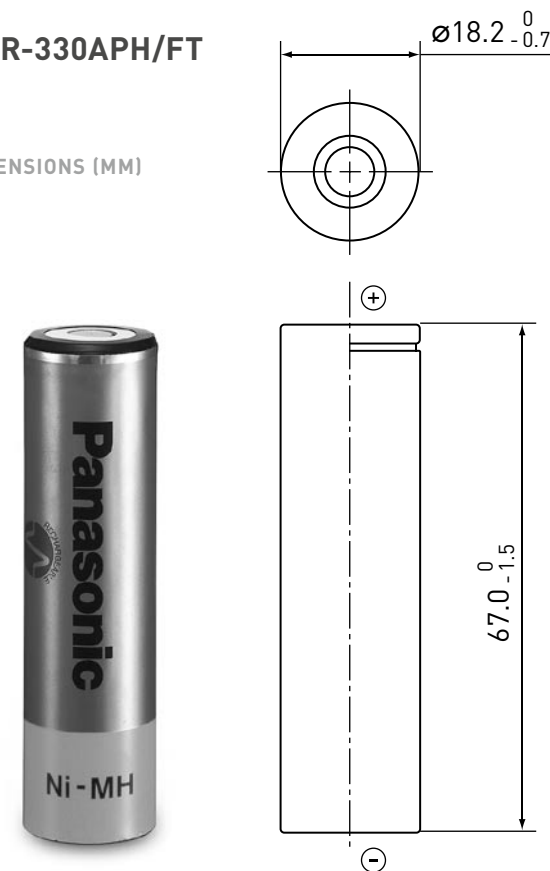

SPECIFICATIONS

Name		HHR-330APH/FT	
Diameter (mm)		18.2 +0/-0.7	
Height (mm)		67.0 +0/-1.5	
Approximate weight (g)		60	
Nominal voltage (V)		1.2	
Discharge capacity*1	Average*2 (mAh)	3,300	
	Rated/min. (mAh)	3,200	
Approx. internal impedance at 1,000Hz at charged state (mΩ)		5.5	
Charge	Standard (mA x hrs.)	330 x 16	
	Rapid*3 (mA x hrs.)	1,650 x 2.4	
	Low rate (mA x hrs.)	165 x 32	
		100 x 48	
Ambient temperature	Charge (°C)	Standard	-10 to +60
		Rapid	-10 to +45
		Low rate	-10 to +45
Discharge (°C)	Standard	-10 to +60	
	Rapid	-10 to +45	
	Low rate	-10 to +45	
Storage (°C)	<1 year	-20 to +35	
	<6 months	-20 to +45	
	<1 month	-20 to +55	
	<1 week	-20 to +65	

*1 After charging at 0.1It for 16 hours, discharging at 0.2It.

*2 For reference only.

*3 Need specially designed control system. Please contact Panasonic for details.

Battery performance and cycle life are strongly affected by how they are used. In order to maximize battery safety, please consult Panasonic when determining charge/discharge specs, warning label contents and design. The data in this document are for descriptive purposes only and are not intended to make or imply any guarantee or warranty.

CYLINDRICAL LFAT/A SIZE FOR BACK-UP USE

TYPICAL CHARGE CHARACTERISTICS

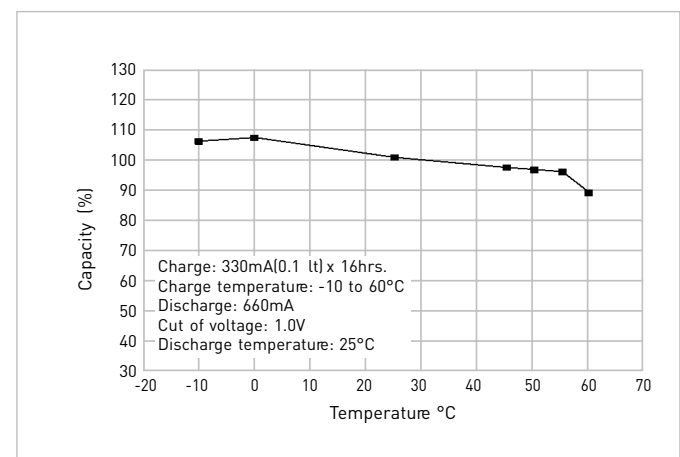
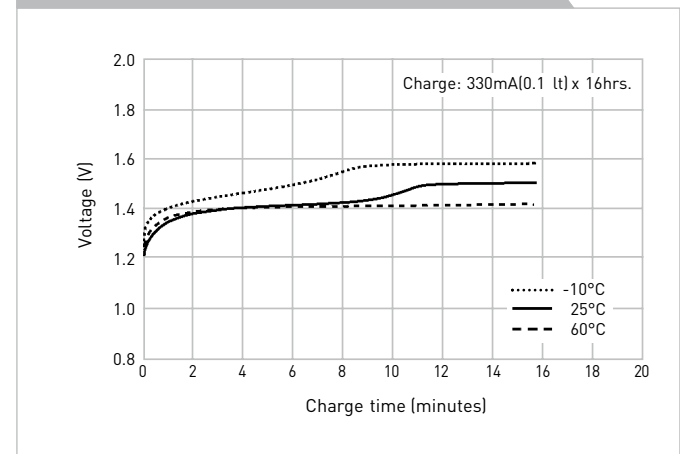

TYPICAL DISCHARGE CHARACTERISTICS

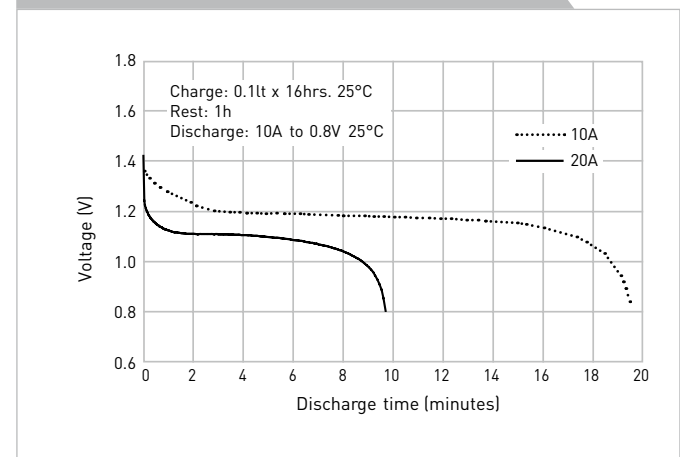

INDIVIDUAL DATA SHEETS

HHR-370AH/FT

DIMENSIONS (MM)

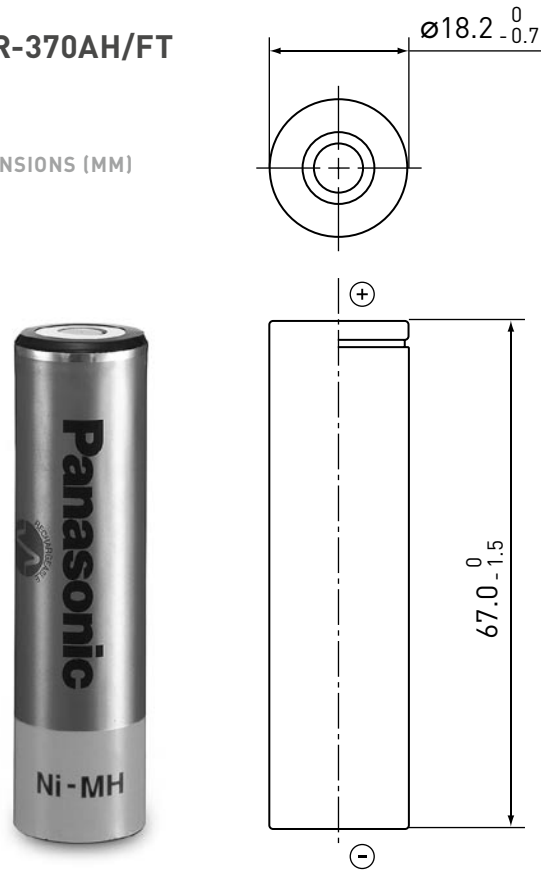

SPECIFICATIONS

Name		HHR-370AH/FT	
Diameter (mm)		18.2 +0/-0.7	
Height (mm)		67.0 +0/-1.5	
Approximate weight (g)		60	
Nominal voltage (V)		1.2	
Discharge capacity*1	Average*2 (mAh)	3,700	
	Rated/min. (mAh)	3,500	
Approx. internal impedance at 1,000Hz at charged state (mΩ)		20	
Charge	Standard (mA x hrs.)	370 x 16	
	Rapid*3 (mA x hrs.)	3,000 x 2.4	
	Low rate (mA x hrs.)	185 x 32	
		123 x 48	
Ambient temperature	Charge (°C)	Standard	-10 to +60
		Rapid	-10 to +45
		Low rate	-10 to +45
Discharge (°C)	Standard	-10 to +60	
	Rapid	-10 to +45	
	Low rate	-10 to +45	
Storage (°C)	<1 year	-20 to +35	
	<6 months	-20 to +45	
	<1 month	-20 to +55	
	<1 week	-20 to +65	

CYLINDRICAL LFAT/A SIZE FOR BACK-UP USE

TYPICAL CHARGE CHARACTERISTICS

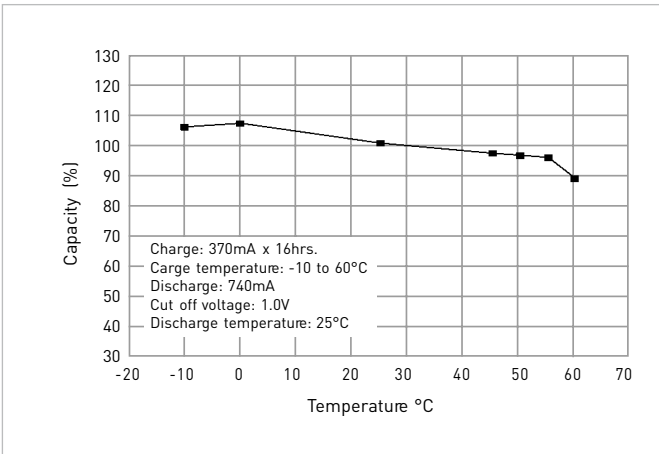
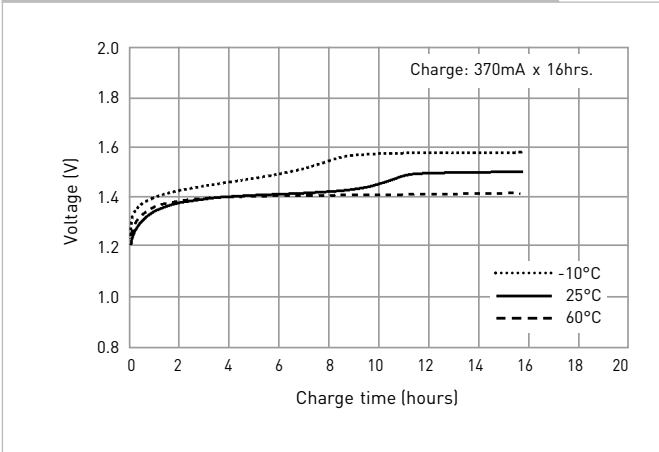

TYPICAL DISCHARGE CHARACTERISTICS

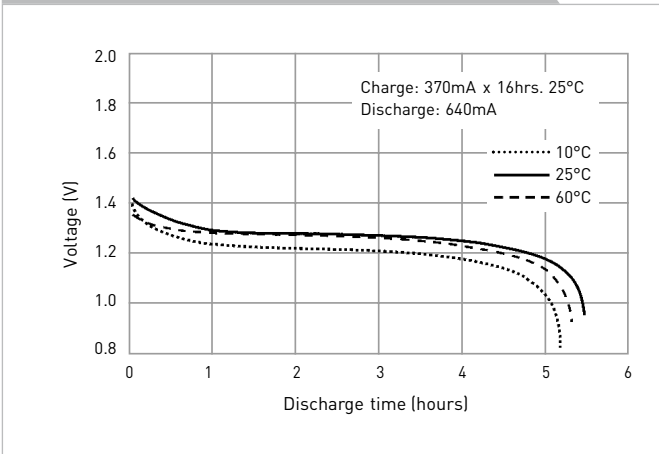

*1 After charging at 0.1It for 16 hours, discharging at 0.2It.
 *2 For reference only.
 *3 Need specially designed control system. Please contact Panasonic for details.

Battery performance and cycle life are strongly affected by how they are used. In order to maximize battery safety, please consult Panasonic when determining charge/discharge specs, warning label contents and design. The data in this document are for descriptive purposes only and are not intended to make or imply any guarantee or warranty.

INDIVIDUAL DATA SHEETS

HHR-250SCH/FT CYLINDRICAL SC SIZE (HR23/43) FOR BACK-UP USE

DIMENSIONS (MM)

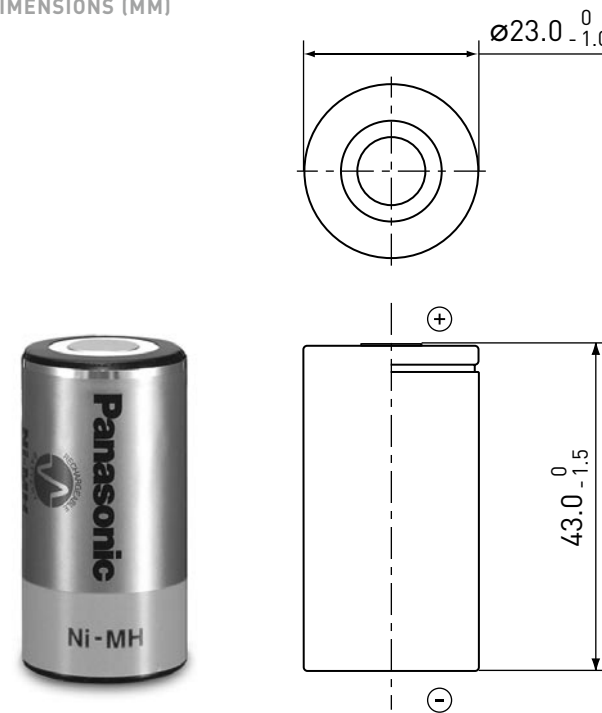

SPECIFICATIONS

Name		HHR-250SCH/FT	
Diameter (mm)		23.0 +0/-1.0	
Height (mm)		43.0 +0/-1.5	
Approximate weight (g)		55	
Nominal voltage (V)		1.2	
Discharge capacity*1	Average*2 (mAh)	2,650	
	Rated/min. (mAh)	2,500	
Approx. internal impedance at 1,000Hz at charged state (mΩ)		5	
Charge	Standard (mA x hrs.)	250 x 16	
	Rapid*3 (mA x hrs.)	1,250 x 2.4	
	Low rate (mA x hrs.)	125 x 32	
		83 x 48	
Ambient temperature	Charge (°C)	Standard	-10 to +60
		Rapid	-10 to +45
		Low rate	-10 to +45
Discharge (°C)	Standard	-10 to +60	
	Rapid	-10 to +45	
	Low rate	-10 to +45	
Storage (°C)	<1 year	-20 to +35	
	<6 months	-20 to +45	
	<1 month	-20 to +55	
	<1 week	-20 to +65	

TYPICAL CHARGE CHARACTERISTICS

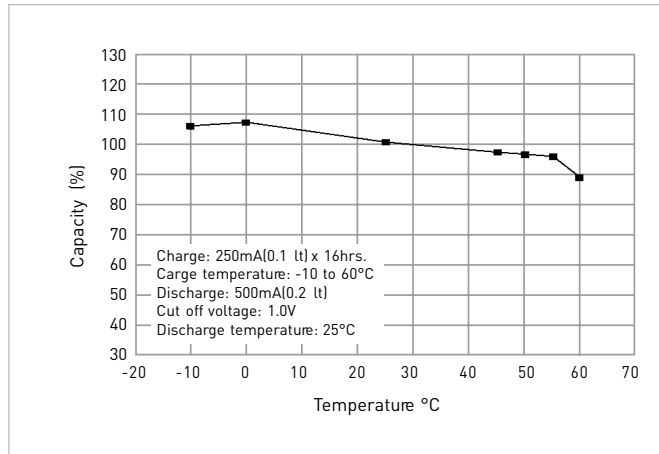
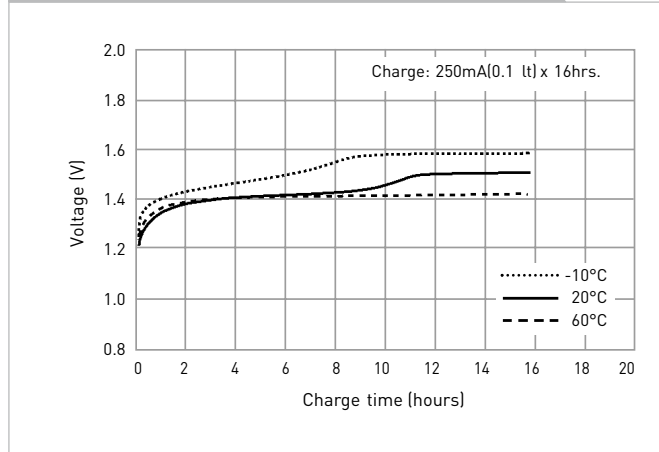

TYPICAL DISCHARGE CHARACTERISTICS

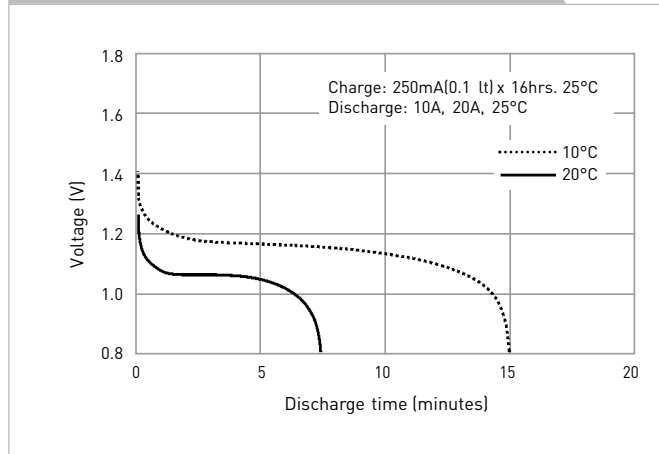

*1 After charging at 0.1It for 16 hours, discharging at 0.2It.
 *2 For reference only.
 *3 Need specially designed control system. Please contact Panasonic for details.

Battery performance and cycle life are strongly affected by how they are used. In order to maximize battery safety, please consult Panasonic when determining charge/discharge specs, warning label contents and design. The data in this document are for descriptive purposes only and are not intended to make or imply any guarantee or warranty.

HHR-300CH/FT

DIMENSIONS (MM)

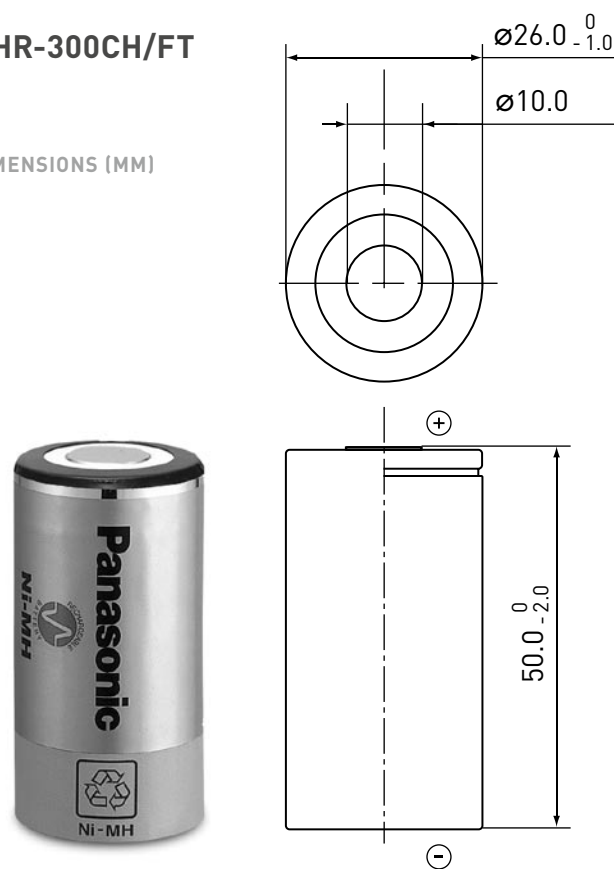

CYLINDRICAL C SIZE (HR26/50) FOR BACK-UP USE

TYPICAL CHARGE CHARACTERISTICS

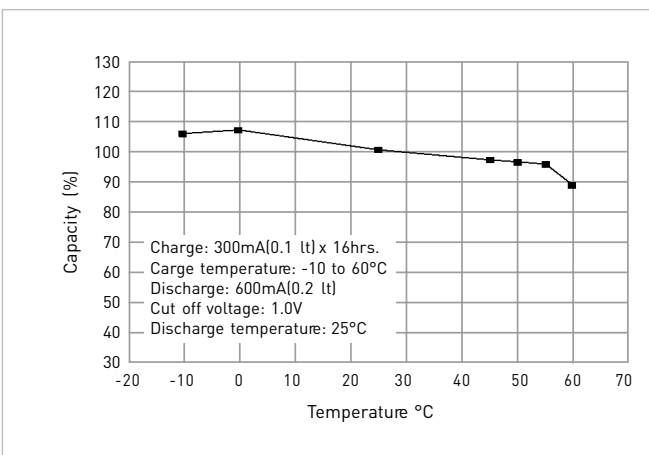
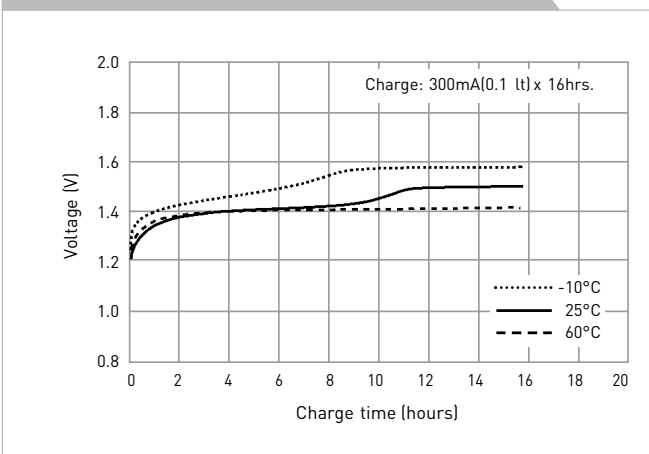

TYPICAL DISCHARGE CHARACTERISTICS

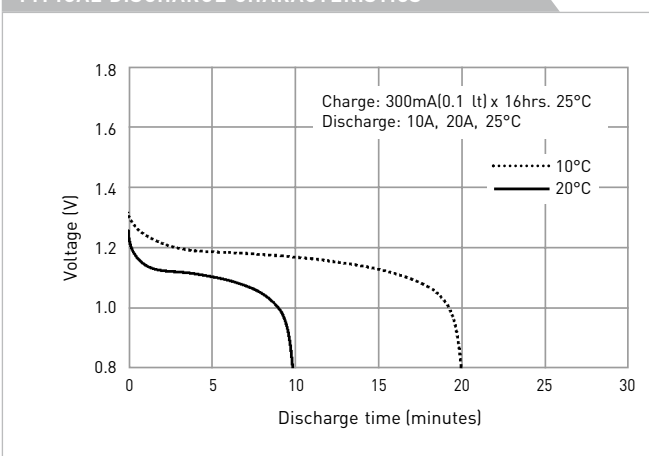

SPECIFICATIONS

Name	HHR-300CH/FT	
Diameter (mm)	26.0 +0/-1.0	
Height (mm)	50.0 +0/-2.0	
Approximate weight (g)	80	
Nominal voltage (V)	1.2	
Discharge capacity*1	Average*2 (mAh)	3,300
	Rated/min. (mAh)	3,100

Approx. internal impedance at 1,000Hz at charged state (mΩ)

5

Charge	Standard (mA x hrs.)		300 x 16
	Charge (°C)	Rapid*3 (mA x hrs.)	1,500 x 2.4
Low rate (mA x hrs.)		150 x 32	
		100 x 48	
Discharge (°C)	Standard	-10 to +60	
	Rapid	-10 to +45	
	Low rate	-10 to +60	
Storage (°C)	<1 year	-20 to +35	
	<6 months	-20 to +45	
	<1 month	-20 to +55	
	<1 week	-20 to +65	

*1 After charging at 0.1It for 16 hours, discharging at 0.2It.

*2 For reference only.

*3 Need specially designed control system. Please contact Panasonic for details.

Battery performance and cycle life are strongly affected by how they are used. In order to maximize battery safety, please consult Panasonic when determining charge/discharge specs, warning label contents and design. The data in this document are for descriptive purposes only and are not intended to make or imply any guarantee or warranty.

Purpose of packs

For the most part, Ni-MH batteries are used in battery packs when installed in products. When these batteries are used, the type of battery, number of cells, shape of the pack, constituent parts of the pack, etc., are determined by the specifications (voltage, load current) of the product. In addition, the charge specifications, space available in the battery compartment, operating conditions, etc., must also be considered. At Panasonic, we are working on the promotion of battery packs which emphasize the safety and reliability of the batteries. We customize packs in the shapes that satisfy the unique requirements of each of our customers. **Do not hesitate to contact us regarding your specific needs.**

Shapes of battery packs (Typical & Standard Types)

F Type

The required number of single cells are arranged side by side along their diameter connected by nickel plates and packed together with heat-shrinkable tubing.

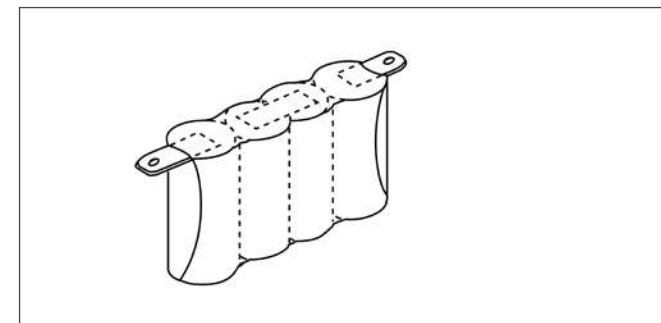

Composite F Type

Single cells are connected in the F type configuration but in two to five rows rather than one row and packed together by heat-shrinkable tubing.

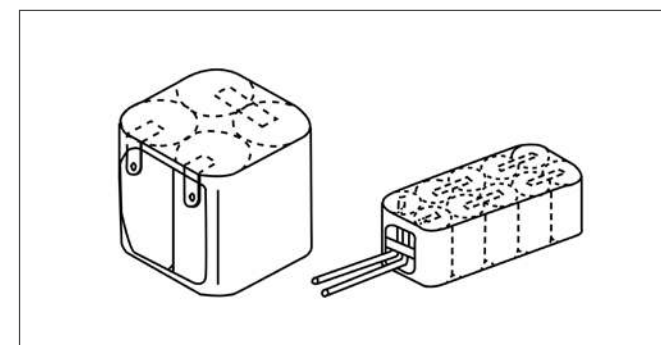

L Type

The required number of single cells are arranged in a line in the axis of the batteries connected by connecting plates and packed together by heat-shrinkable tubing.

Composite L Type

Single cells connected in the L type configuration are further connected in two to five rows and packed together by heat-shrinkable tubing.

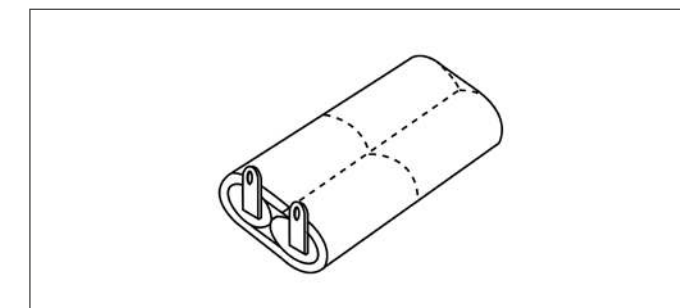

STRUCTURAL-RELATED ITEMS

Active material

The electro-chemical materials of the electrodes. In rechargeable Ni-MH battery, nickel-hydroxide is the active material of the positive electrode and hydrogen-absorbing alloy is the active material of the negative electrode.

Cell

Each of the individual batteries which comprise a rechargeable battery.

Electrolyte

The medium through which ions are conducted during the electro-chemical reaction inside a rechargeable battery. In rechargeable Ni-MH battery, a potassium hydroxide water solution is generally used as the electrolyte.

Hydrogen-absorbing alloy

Alloy which can absorb/release hydrogen reversibly. AB_5 or AB_2 type alloy is used for batteries. $[MmNi_5]$ AB_5 type is employed in Panasonic's products.

Negative electrode

The electrode that has a lower electrical potential than the positive electrode to which electrical current flows from the external circuit during the discharge of a storage battery.

Nickel Oxyhydroxide

Expressed in chemical notation as $NiOOH$, this indicates that the positive electrode material of the Ni-MH battery is in a charged state. When in the discharged state, the positive electrode material becomes nickel hydroxide, or $Ni(OH)_2$.

Pasted type electrode plate

An electrode plate made by applying the active material (hydrogen-absorbing compound) in a paste form onto a nickel-plated steel porous plate. Used as the negative electrode.

Positive electrode

The positive electrode that has a higher electrical potential than the negative electrode from which electrical current

flows to the external circuit during the discharge of a rechargeable battery.

Safety vent

Functions to release the gas when the internal pressure exceeds a predetermined level. In addition to preventing the absorption of external air into the rechargeable battery, this vent also prevents the rupture of the rechargeable battery that would result from the increase in the internal pressure caused by the generation of gas during charge or at other times.

Separator

A porous or micro-porous thin plate, cloth, bar or frame which is inserted as a spacer between the positive and negative electrode plates for the purpose of preventing short-circuits. The separator must be non-oxidizing, resistant to chemicals, and be an electrical insulator, and it must not obstruct in any way the ionic conduction or diffusion of the electrolyte. The separator also functions to retain the electrolyte.

ELECTRICAL-RELATED ITEMS

Capacity

The electrical capacity of a rechargeable battery. Normally used to mean the capacity as measured in ampere-hours. Indicated in units of Ah (ampere hours) or C (coulombs).

Charge efficiency

A general term meaning either ampere-hour efficiency or watt-hour efficiency. More commonly used to mean ampere-hour efficiency.

Charge level

The amount of electricity used for charge. For constant current charge, it is the product of multiplying the current value by the charge time. Measured in units of ampere-hours (Ah).

C (Coulomb)

Used to express the amount of the charge or discharge current. Expressed by attaching the current units to a

numerical multiple that represents the rated capacity of the battery. The charge and discharge current are generally expressed using a C multiple. For example, for a battery having a rated capacity of 1500mAh:

$$0.1CmA = 0.1 \times 1500 = 150mA$$

$$0.2CmA = 0.2 \times 1500 = 300mA$$

Cut-off discharge voltage

The voltage that indicates the limit at which discharge is completed. In practical use, this voltage is the limit to which the battery can be used.

Electrolyte leakage

The penetration of the electrolyte to the outside of the battery.

Energy density

The amount of energy that can be obtained per unit weight or per unit volume of a rechargeable battery. Unit: wh/kg, wh/l.

Excessive discharge

The discharge of a rechargeable battery to lower than the specified cut-off discharge voltage.

High rate discharge

Discharge at a relatively large current with respect to the battery capacity. Also called high efficiency discharge and high-current discharge.

Nominal voltage

The voltage used to indicate the battery voltage. Generally a value slightly lower than the electromotive force is used. For example, the nominal voltage of rechargeable Ni-MH batteries is 1.2V per cell.

Open circuit voltage

The voltage of a battery when that battery is electrically cut-off from the external circuit.

Overcharge current

Charge after the fully charged state has been reached. In a rechargeable battery that requires water replenishment,

the electrolysis of the water causes a sharp decrease in the amount of electrolyte. Generally, the overcharge of a rechargeable battery will shorten the battery's cycle life.

Rapid charge

Charge quickly using a large current.

Rated capacity

The standard value for the amount of electricity which can be obtained from the battery in a fully charged state at the specified temperature, discharge current, and cut-off discharge voltage. Measured in units of ampere-hours (Ah). Note that CN is used as a symbol to express the rated capacity at a rate of N hours.

Reverse charge

Charge with the polarities reversed. If the polarities are reversed, all of the electrical energy will be used to generate gas.

Self-discharge

A decrease in the capacity of a rechargeable battery without any discharge of current to the external circuit.

OTHER TERMS

Alkaline storage battery

A storage battery that uses an alkaline water solution as its electrolyte. Generally refers to Ni-MH batteries.

Cycle use

A method of use in which charge and discharge are repeated over and over again.

IEC Standards

The standards established by the International Electro-technical Commission (IEC).

CONTACT

United Kingdom/Ireland

Panasonic Industrial Europe GmbH
Willoughby Road
Bracknell Berkshire
RG12 8FP
England
Phone: +44 1344 - 853260
Fax: +44 1344 - 853313

Italy

Panasonic Italia S.p.A.
Viale dell'Innovazione 3
20125 Milano
Italy
Phone: +39 02 - 6788 - 506
Fax: +39 02 - 6788 - 207

Spain/Portugal

Panasonic Industrial Europe GmbH
Sucursal en España
Parque Empresarial @ Sant Cugat,
Via Augusta 15-25
Edificio B2 Planta 4 Oficina 17
08174 Sant Cugat del Vales
Barcelona
Spain
Phone: +34 93 - 504 30 10
Fax: +34 93 - 675 58 92

France

Panasonic Industrial Europe GmbH
10, rue des petits ruisseaux
91370 Verrières-le-Buisson
France
Phone: +33 1 - 60 13 57 62
Fax: +33 1 - 60 13 57 72

Germany

(all other European countries)

Panasonic Industrial Europe GmbH
Winsbergring 15
22525 Hamburg
Germany
Phone: +49 40 - 85386 - 157
Fax: +49 40 - 85386 - 238

E-mail and Website for all countries

battery-solutions@eu.panasonic.com
<http://industrial.panasonic.com/eu>



Notice to Readers

It is the responsibility of each user to ensure that every battery application is adequately designed safe and compatible with all conditions encountered during use, and in conformance with existing standards and requirements. This literature contains information concerning cells and batteries manufactured by Panasonic Corporation. This information is generally descriptive only and is not intended to make or imply any representation, guarantee or warranty with respect to any cells and batteries. Cell and battery designs are subject to modification without notice.

This catalog has been produced using unchlorinated paper.

For more details please contact:

Panasonic

Panasonic is a registered trademark
of Panasonic Corporation.
Printed in Germany.
© Panasonic Corporation