

DATA SHEET

CURRENT SENSOR-LOW TCR

PF0603-series

5%,1%,

size 0603

RoHS Compliant & Halogen Free



SCOPE

This specification describes PF0603 current sensor – low TCR chip resistors with lead-free terminations.

APPLICATIONS

- Power supplies
- Consumer(Mobile、PNDs、...)
- Laptop
- HDDs

FEATURES

- Products with lead free terminations meet RoHS requirements.
- High component and equipment reliability with high power rating 0.33W (1/3W).
- Low resistance 10mΩ and narrow tolerance ±1% can suitable for current detection.

ORDERING INFORMATION - GLOBAL PART NUMBER

Part number is identified by the series name, size, tolerance, packaging type, temperature coefficient of resistance, taping reel, resistance value.

PF0603 X X X XX XXXX Z
 (1) (2) (3) (4) (5) (6)

(1) TOLERANCE

F = ±1%

J = ±5%

(2) PACKAGING TYPE

R = Paper/PE taping reel

(3) TEMPERATURE COEFFICIENT OF RESISTANCE

E=±50ppm/°C, M=±75ppm/°C, F=±100ppm/°C

(4) TAPING REEL

07 = 7 inch dia. Reel & 0.1W(1/10W)

7W = 7 inch dia. Reel & Power Rating 0.2W(1/5W)

7T = 7 inch dia. Reel & Power Rating 0.33W(1/3W)

47 = 7 inch dia. Reel & Power Rating 0.4W

57 = 7 inch dia. Reel & Power Rating 0.5W

(5) RESISTANCE VALUE

0R01 (10mR) to 0R1 (100mR)

(6) Default Code

Letter Z is system default code for order only^(NOTE)

ORDERING EXAMPLE

The ordering code for a PF0603 0.2W chip resistor, TC100 value 0.068Ω(68mR) with ±1% tolerance, supplied in 7-inch tape reel with 5Kpcs quantify is:

PF0603FRF7W0R068Z.

NOTE

1. All our RSMD products meet RoHS compliant and Halogen Free. "LFP" of the internal 2D reel label mentions "Lead Free Process".

2. On customized label, "LFP" or specific symbol can be printed.

MARKING

PF0603:

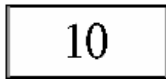
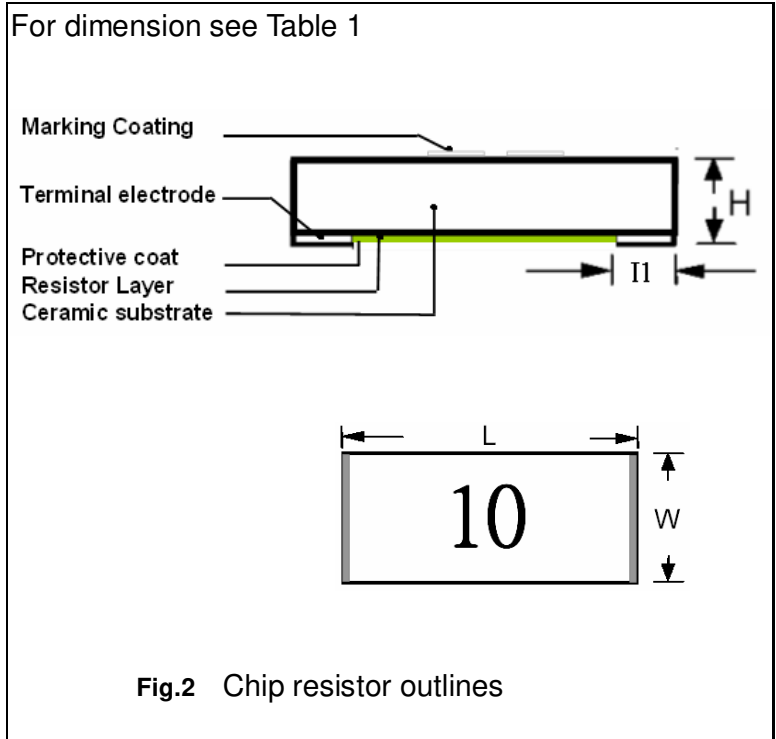

Fig.1 Value=10mΩ

CONSTRUCTION

The resistors are constructed out of a high-grade ceramic body. Internal metal electrodes are added at each end and connected by a resistive paste. The composition of the paste is adjusted to give the approximate required resistance and laser cutting of this resistive layer that achieves tolerance trims the value. The resistive layer is covered with a protective coat and printed with the resistance value. Finally, the two external terminations (matte tin) are added. See fig. 2.

OUTLINES



DIMENSIONS

Table 1

TYPE	PF0603
L (mm)	1.60±0.20
W (mm)	0.80±0.20
H (mm)	0.60±0.15
l1 (mm)	0.30±0.15

ELECTRICAL CHARACTERISTICS

Table 2

CHARACTERISTICS	PF0603 0.1W;0.2W;0.33W;0.4W;0.5W
Operating Temperature Range	-55°C to +155°C
Maximum Working Voltage	$\sqrt{(P * R)}$
Resistance Range	10mΩ to 100mΩ
Temperature Coefficient	± 50ppm/°C, ± 75ppm/°C, ±100ppm/°C

PACKING STYLE AND PACKAGING QUANTITY

Table 3

PRODUCT TYPE	PACKING STYLE	REEL DIMENSION	QUANTITY PER REEL
PF0603	Paper taping reel	7" (178 mm)	5,000 Units

FUNCTIONAL DESCRIPTION

POWER RATING

PF0603 rated power at 70°C is 0.1W; 0.2W ; 0.33W; 0.4W and 0.5W

RATED VOLTAGE

The DC or AC (rms) continuous working voltage corresponding to the rated power is determined by the following formula:

$$U = \sqrt{(P * R)}$$

Where

U=Continuous rated DC

or AC (rms) working voltage (v)

P=Rated power

R=Resistance value (Ω)

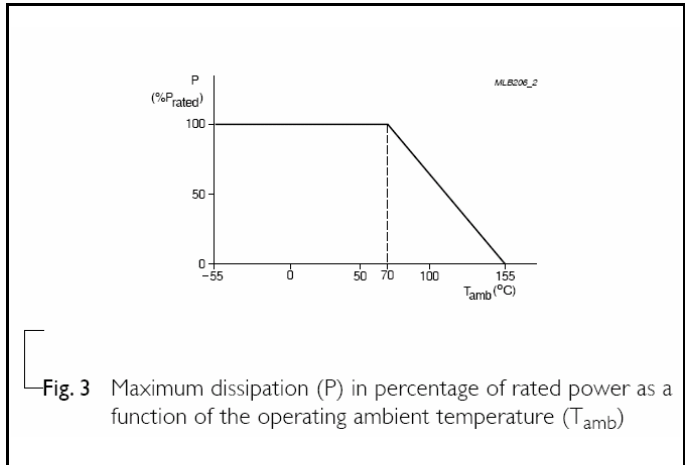

Fig. 3 Maximum dissipation (P) in percentage of rated power as a function of the operating ambient temperature (T_{amb})

TAPING REEL

Table 4

DIMENSION	0603
Tape Width(mm)	8
ØA (mm)	180.0+0/-3
ØN (mm)	60.0+1/-0
ØC (mm)	13.0±0.2
ØD (mm)	21.0±0.8
W1 (mm)	8.4 +1/-0
W2 (mm)	Max 18.4

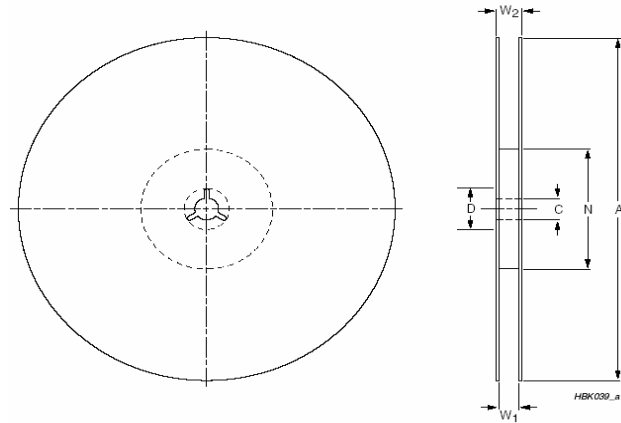

Fig.4 Reel

PAPER/PE TAPE SPECIFICATION

Table 5

DIMENSION	0603
A ₀ (mm)	1.10±0.15
B ₀ (mm)	1.90±0.15
W (mm)	8.0±0.30
E (mm)	1.75±0.10
F (mm)	3.50±0.10
P ₀ (mm)	4.0±0.10
P ₁ (mm)	4.0±0.10
P ₂ (mm)	2.0±0.10
D ₀ (mm)	1.50±0.10
T (mm)	0.85±0.15

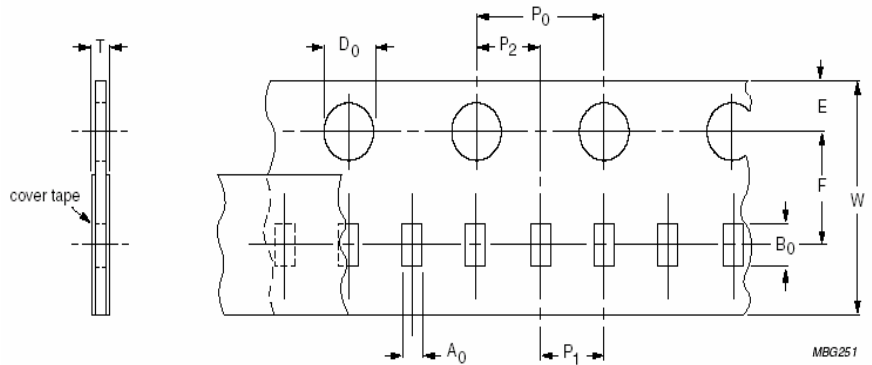

Fig.5 Paper/PE tape

FOOTPRINT DIMENSION

Size Footprint	Dimensions		Code	unit :mm
PF0603	A	B	C	D
	2.10	0.60	0.75	0.92

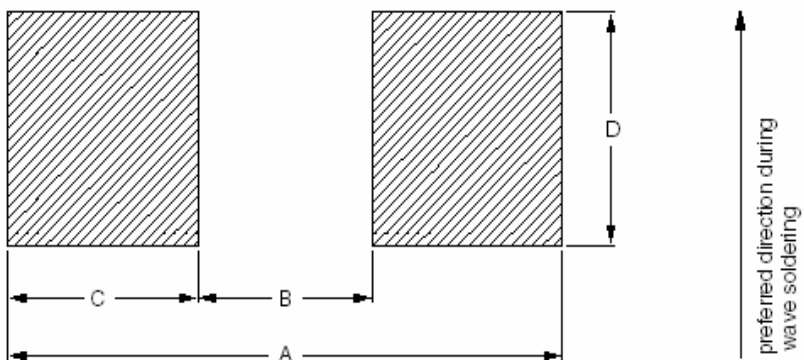

Fig.6 RECOMMENDED FOOTPRINT DIMENSIONS

TESTS AND REQUIREMENTS

TEST	TEST METHOD	PROCEDURE	REQUIREMENT
Life/ Endurance	IEC 60115-1 4.25.1	1,000 hours at 70±5 °C applied RCWV 1.5 hours on, 0.5 hour off, still air required	± (1.0 % + 0.0005 Ω)
High Temperature Exposure/ Endurance at upper category temperature	IEC 60068-2-2	1,000 hours at 155±5 °C,unpowered	± (1.0 % + 0.0005 Ω)
Moisture Resistance	MIL-STD-202 Method 106G	Each temperature / humidity cycle is defined at 8 hours (Method 106G), 3 cycles / 24 hours for 10d. with 25 °C / 65 °C 95% R.H, without steps 7a & 7b, un-powered Parts mounted on test-boards, without condensation on parts Measurement at 24±2 hours after test conclusion.	± (0.5% + 0.0005 Ω)
Thermal Shock	MIL-STD-202 Method 107G	-55/+125 °C Note: Number of cycles required is 300. Devices unmounted Maximum transfer time is 20 seconds. Dwell time is 15 minutes. Air – Air	± (1.0% + 0.0005 Ω)
Short time overload	IEC 60115-1 4.13	Applied 5 times of rating power 5 seconds at room temperature	± (0.5% + 0.0005 Ω) No visible damage
Board Flex/ Bending	IEC 60068-2-21	Chips mounted on a 90mm glass epoxy resin PCB(FR4) 2 mm bending Bending time: 60±1 seconds	± (1.0 % + 0.0005 Ω)
Solderability - Wetting	IPC/JEDEC J-STD-002B test B	Electrical Test not required Magnification 50X SMD conditions: 1st step: Method B, aging 4 hours at 155 °C dry heat 2nd step: leadfree solder bath at 245±3 °C Dipping time: 3±0.5 seconds	Well timed (≥95% covered) No visible damage
- Leaching	IPC/JEDEC J-STD-002B test D	Leadfree solder, 260 °C, 30 seconds immersion time	No visible damage
- Resistance to Soldering Heat	IEC 60068-2-58	Condition B, no pre-heat of samples Leadfree solder, 260±5 °C, 10±1seconds immersion time Procedure 2 for SMD: devices fluxed and cleaned with isopropanol	± (0.5% + 0.0005 Ω) No visible damage

REVISION HISTORY

REVISION	DATE	CHANGE NOTIFICATION	DESCRIPTION
Version 0	2010-02-17		- First issue of this specification
Version 1	2010-12-16		- Range Extension
Version 2	2011-6-15		- Dimension of Paper Tape Modify
Version 3	2011-12-2		- Dimension of Paper Tape Modify