

HCZ-PT | Level indicators with protection frame

SUPER-Technopolymer and transparent technopolymer

INCH



- 1
- 2
- 3
- 4
- 5
- 6
- 7
- 8
- 9
- 10
- 11
- 12
- 13
- 14
- 15
- 16
- 17
- 18

BODY

Transparent polyamide based (PA-T) technopolymer. Highly resistant to shocks, solvents, oils with additives, aliphatic and aromatic hydrocarbons, petrol, naphtha, phosphoric esters.

Avoid contact with alcohol or detergents containing alcohol.

PROTECTION FRAME

Glass-fibre reinforced polyamide based (PA) SUPER-technopolymer, black colour, matte finish. Supplied assembled, removable by a screwdriver.

SCREWS AND NUTS

Zinc-plated steel.

PACKING RINGS

Step-shaped for the seal on the reservoir walls and NBR synthetic rubber O-ring screw underhead.

Suggested roughness of the packing ring application surface $R_a = 3 \mu m$.

CONTRAST SCREEN

White lacquered aluminium. The housing, in the appropriate external rear slot, guarantees the best protection from direct contact with fluid. It can be taken out from the inclined side, before assembly to allow the insertion of level lines or words.

MAXIMUM CONTINUOUS WORKING TEMPERATURE

194°F (90°C), (with oil).

FEATURES AND PERFORMANCES

Ultrasound welding to guarantee a perfect seal.

Maximum fluid level visibility even from side positions.

Lens effect for a better visibility of the fluid level.

TECHNICAL DATA

In laboratory tests carried out with mineral oil type CB68 (according to ISO 3498) at 23°C for a limited period of time, the weld stood up to: 18 bar (HCZ.76 and HCZ.127) 12 bar (HCZ.254).

For use with other fluids and under different pressure and temperature conditions, please contact ELESA Technical Department.

In any case we suggest to verify the suitability of the product under the actual working conditions.



ELESA Original design

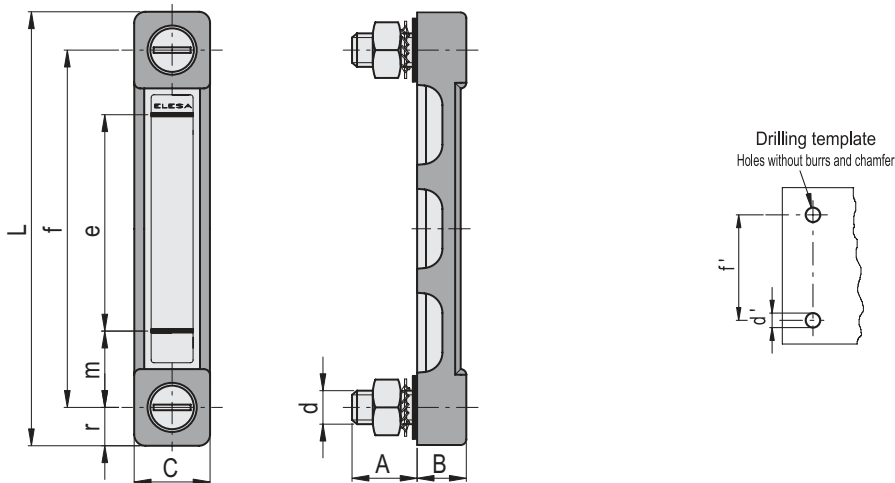

INCH

Code	Description	f	d	A	B	C	L	e	m	r	d'-0.2	f±0.2	C# [ft lb]	⚖
911392	HCZ.76-PT-1/2-13	2.99	1/2-13	0.87	0.69	1.06	4.13	1.57	0.71	0.57	0.41	2.99	9	0.22
911395	HCZ.127-PT-1/2-13	5	1/2-13	0.87	0.69	1.06	6.14	3.15	0.91	0.57	0.49	5	9	0.3
911398	HCZ.254-PT-1/2-13	10	1/2-13	0.87	0.69	1.14	11.18	7.99	0.98	0.61	0.49	10	9	0.33

Accessories for hydraulic systems

2 # Maximum tightening torque.