

Two-Piece 4.0mm Pitch Battery

9155-400

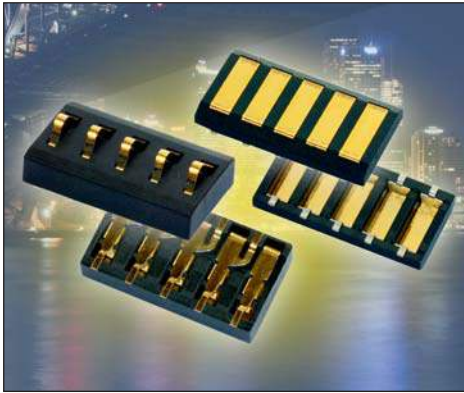

This unique battery or removable module style connector is different from most others in that it allows for the pluggable device to be swiped or connected from either direction. The spring contact offers enhanced contact deflection range over existing connectors in the market with a full 1.4mm of travel after contact engagement. This contact design allows the connector to absorb more of the plastic or housing tolerances making it more functional and reliable in real life applications.

The fixed pad connector is unique in the industry as it replaces the plating of gold directly onto PCB pads. The main benefit of using this connector is to elevate the pad surface well above the PCB so that the gold contacts are close to flush with the outside packaging. This minimizes the distance that a spring contact would need to absorb in the mating tolerance band. Also unique to this connector is the angled contact lead-in on both sides which facilitates smooth engagement of the spring contact from either direction.

APPLICATIONS

- Portable electronics requiring a removable battery
- Interface for removable/pluggable modules or cartridges
- Docking cradle for charging and data transfer

FEATURES AND BENEFITS

- Proven contact reliability in harsh industrial or medical applications
- Increased contact deflection range above existing connectors on the market
- Gold plated Beryllium contact spring contact assures maximum contact reliability and functionality up to 5000 cycles
- Beveled lead in on pad connector facilitates smooth module engagement from either direction

ELECTRICAL

- Current Rating: 5A/contact
- Voltage Rating: 125 VAC

ENVIRONMENTAL

- Operating Temperature: -40°C to +125°C

MECHANICAL

- Contact Material: Spring contact is Be Cu, Fixed contact is Phosphor Bronze
- Contact Plating: Gold over nickel mating area, pure Tin SMT tails
- Durability 5000 Cycles

HOW TO ORDER

00	9155	005
Prefix	Series	Number of Ways
		002 = 2
		003 = 3
		004 = 4
		005 = 5
		006 = 6

40X		
Standard Battery Connector		
Code	Description	Reel Qty.
401	Battery Connector - Sprung Half	550
402	Battery Connector - Fixed Half	1100

00X
Plating Option
6 = 0.4µm Selective Gold, Pure Tin Tail
8 = 0.8µm Selective Gold, Pure Tin Tail



Two-Piece 4.0mm Pitch Battery

9155-400

2 WAY BATTERY CONNECTOR – SPRUNG HALF

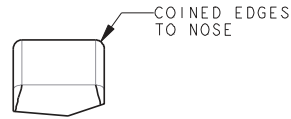
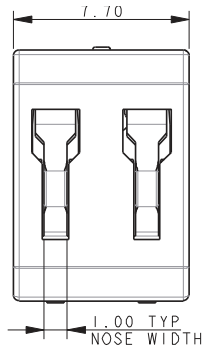

DETAIL A

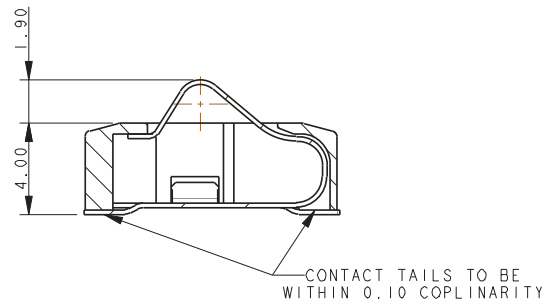
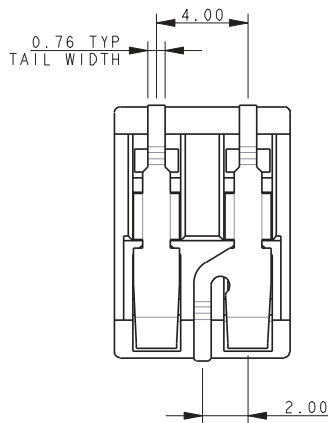
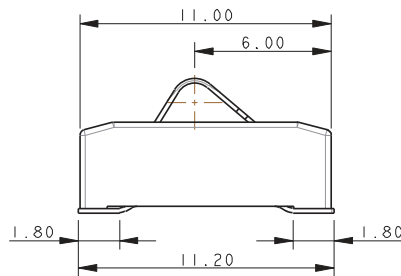
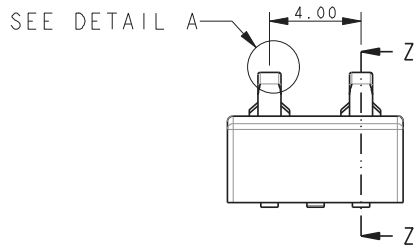

SECTION ON Z-Z

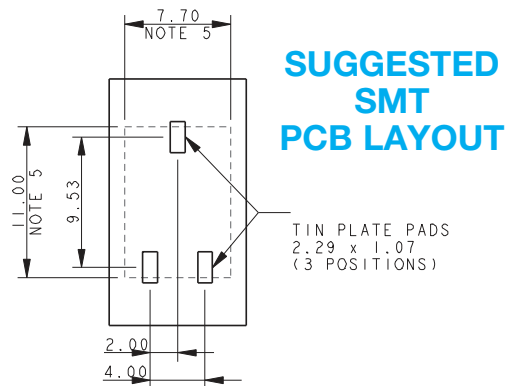
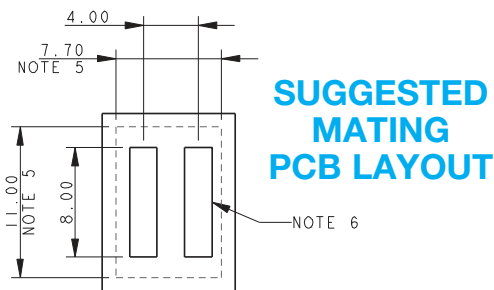

NOTES:

1. GENERAL TOLERANCE ± 0.20 UNLESS OTHERWISE STATED.
2. FOR FURTHER DETAILS REFER TO AVX SPECIFICATION 201-01-207.
3. ADDITIONAL INFORMATION AND BASIC MATING DETAILS REFER TO PAGES 12-14.
4. PACKING DETAILS ON PAGE 15.
5. CONNECTOR OUTLINE.
6. RECOMMENDED PLATING ON MATING PADS. GOLD OVER NICKEL.
7. FOR OTHER TAN VERTICAL MATING WE RECOMMEND MATING WITH THE FIXED CONNECTOR, REFER TO PAGE 13.

Two-Piece 4.0mm Pitch Battery

9155-400

3 WAY BATTERY CONNECTOR – SPRUNG HALF

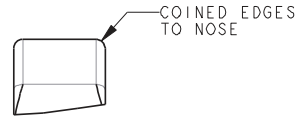
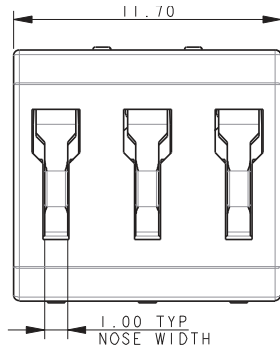

DETAIL A

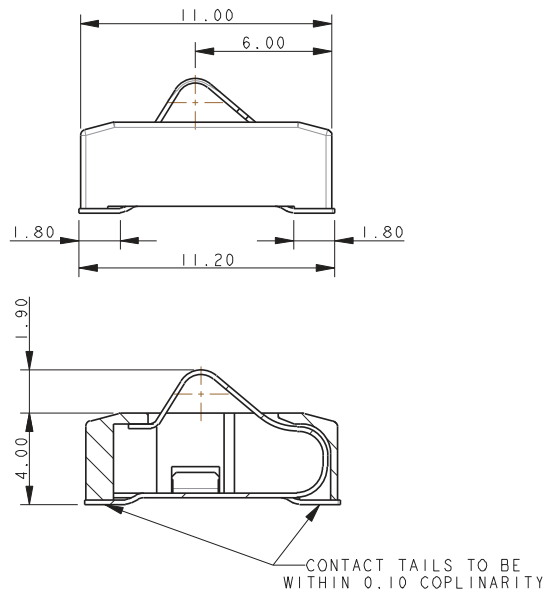
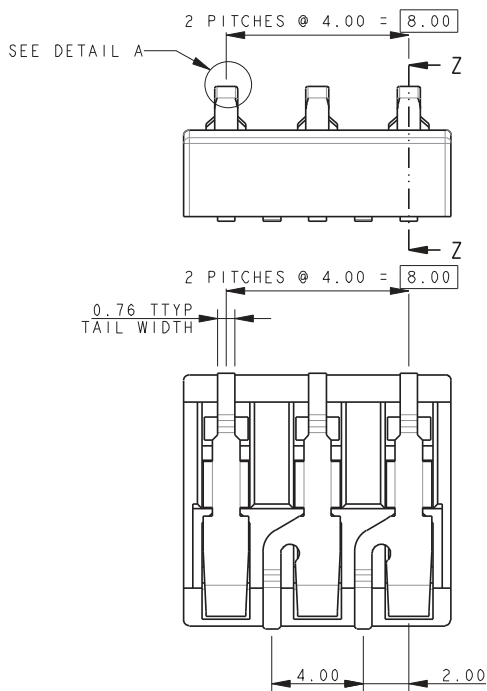

SECTION ON Z-Z

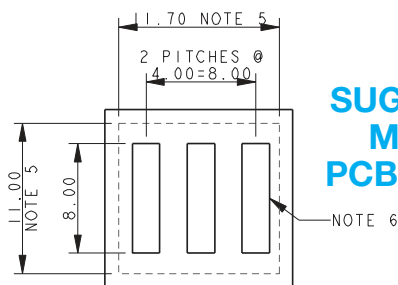

**SUGGESTED
MATING
PCB LAYOUT**

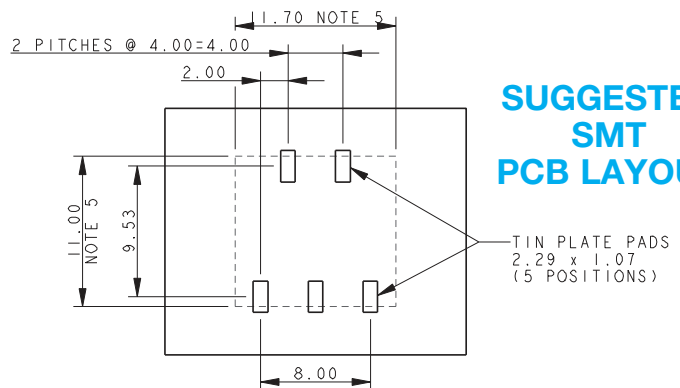

**SUGGESTED
SMT
PCB LAYOUT**

NOTES:

1. GENERAL TOLERANCE ± 0.20 UNLESS OTHERWISE STATED.
2. FOR FURTHER DETAILS REFER TO AVX SPECIFICATION 201-01-207.
3. ADDITIONAL INFORMATION AND BASIC MATING DETAILS REFER TO PAGES 12-14.
4. PACKING DETAILS ON PAGE 15.
5. CONNECTOR OUTLINE.
6. RECOMMENDED PLATING ON MATING PADS. GOLD OVER NICKEL.
7. FOR OTHER TAN VERTICAL MATING WE RECOMMEND MATING WITH THE FIXED CONNECTOR, REFER TO PAGE 13.

Two-Piece 4.0mm Pitch Battery

9155-400

4 WAY BATTERY CONNECTOR – SPRUNG HALF

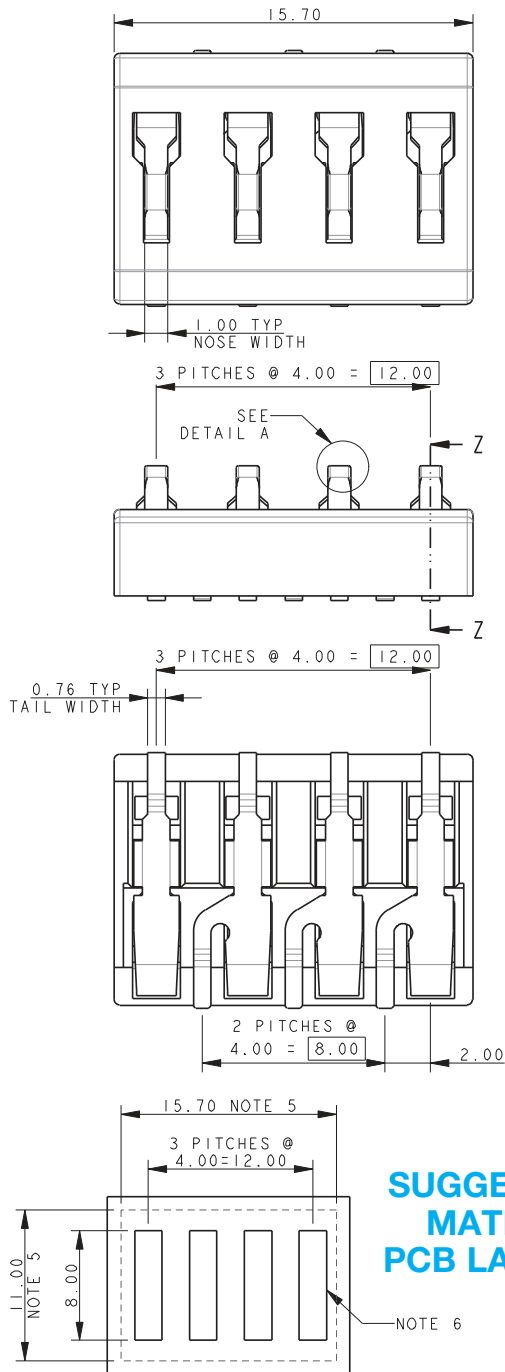

**SUGGESTED
MATING
PCB LAYOUT**

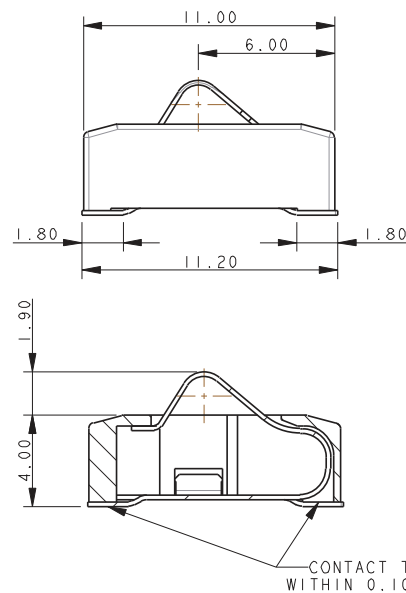
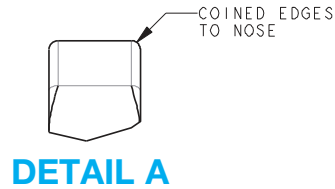

SECTION ON Z-Z

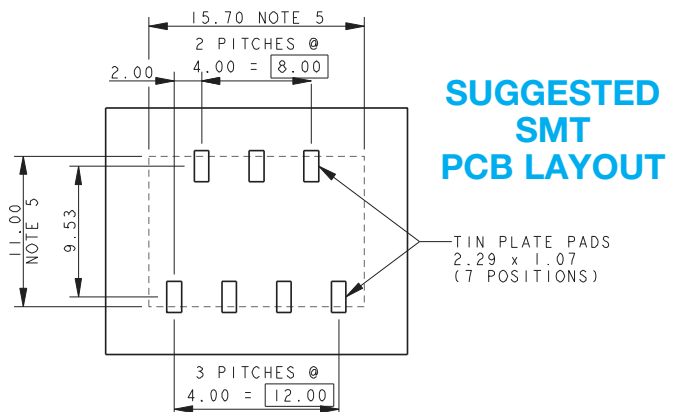

NOTES:

1. GENERAL TOLERANCE ± 0.20 UNLESS OTHERWISE STATED.
2. FOR FURTHER DETAILS REFER TO AVX SPECIFICATION 201-01-207.
3. ADDITIONAL INFORMATION AND BASIC MATING DETAILS REFER TO PAGES 12-14.
4. PACKING DETAILS ON PAGE 15.
5. CONNECTOR OUTLINE.
6. RECOMMENDED PLATING ON MATING PADS. GOLD OVER NICKEL.
7. FOR OTHER TAN VERTICAL MATING WE RECOMMEND MATING WITH THE FIXED CONNECTOR, REFER TO PAGE 13.

Two-Piece 4.0mm Pitch Battery

9155-400

5 WAY BATTERY CONNECTOR – SPRUNG HALF

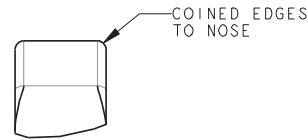
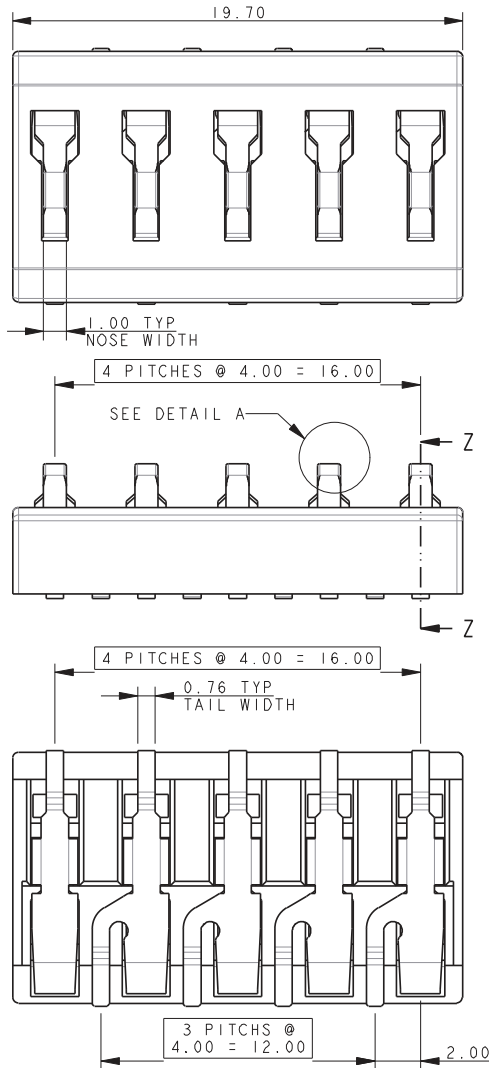

DETAIL A

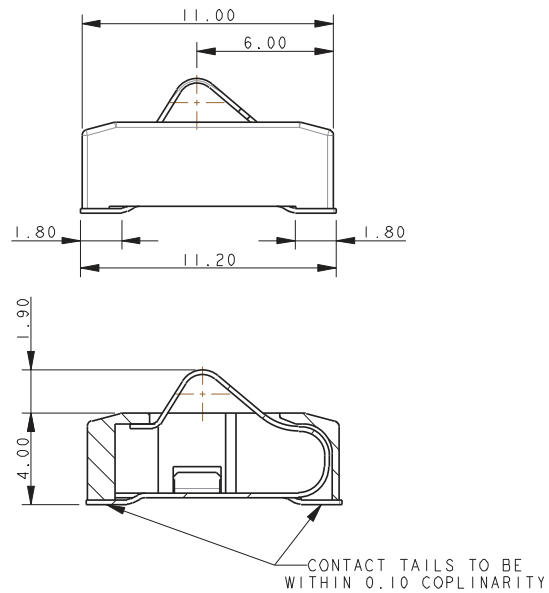

SECTION ON Z-Z

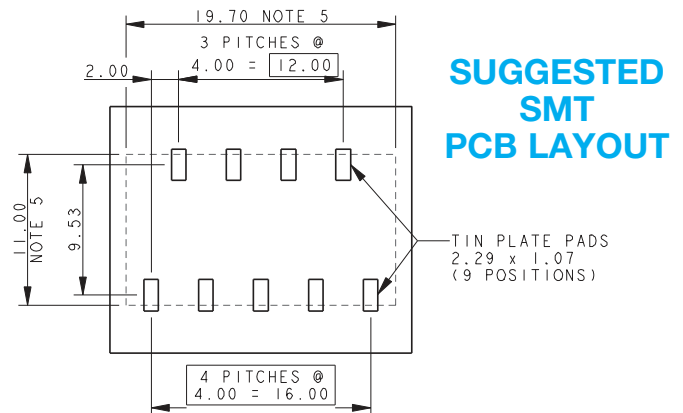
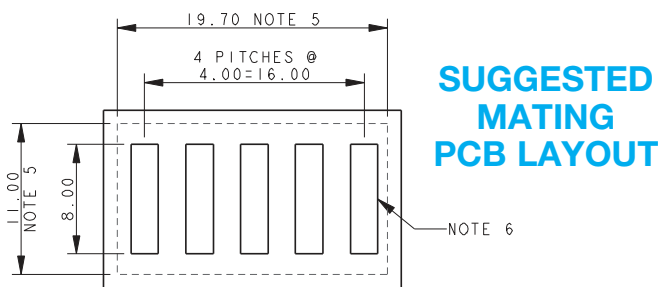

NOTES:

1. GENERAL TOLERANCE ± 0.20 UNLESS OTHERWISE STATED.
2. FOR FURTHER DETAILS REFER TO AVX SPECIFICATION 201-01-207.
3. ADDITIONAL INFORMATION AND BASIC MATING DETAILS REFER TO PAGES 12-14.
4. PACKING DETAILS ON PAGE 15.
5. CONNECTOR OUTLINE.
6. RECOMMENDED PLATING ON MATING PADS. GOLD OVER NICKEL.
7. FOR OTHER TAN VERTICAL MATING WE RECOMMEND MATING WITH THE FIXED CONNECTOR, REFER TO PAGE 13.

Two-Piece 4.0mm Pitch Battery

9155-400

6 WAY BATTERY CONNECTOR – SPRUNG HALF

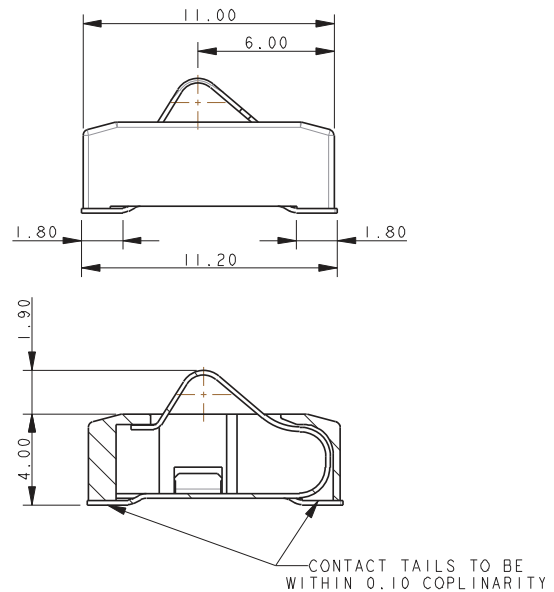
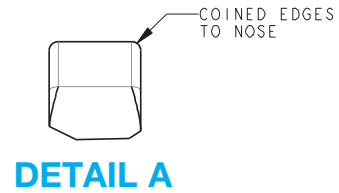
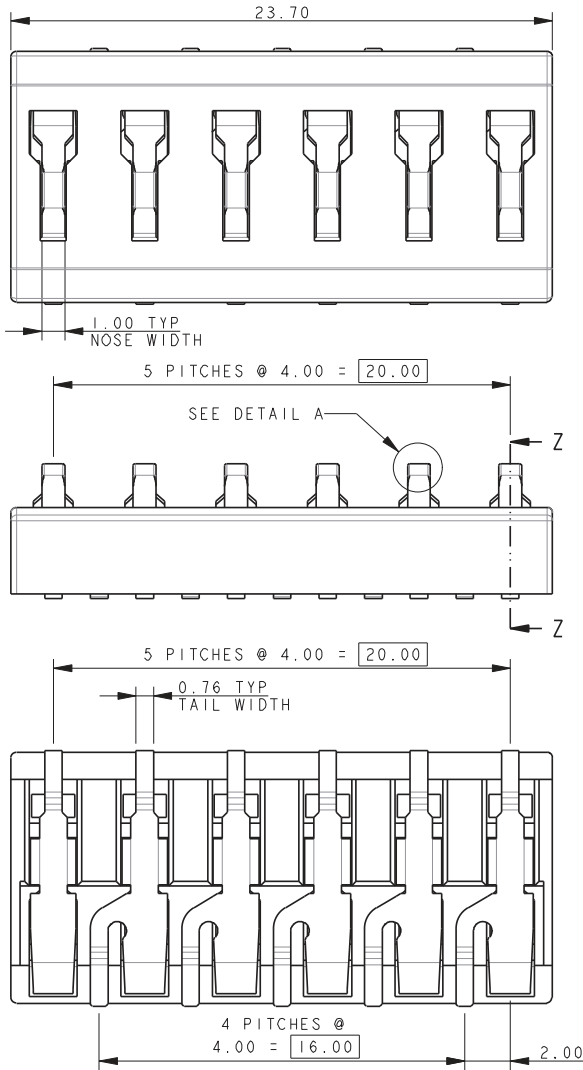

SECTION ON Z-Z

SUGGESTED SMT PCB LAYOUT

SUGGESTED MATING PCB LAYOUT

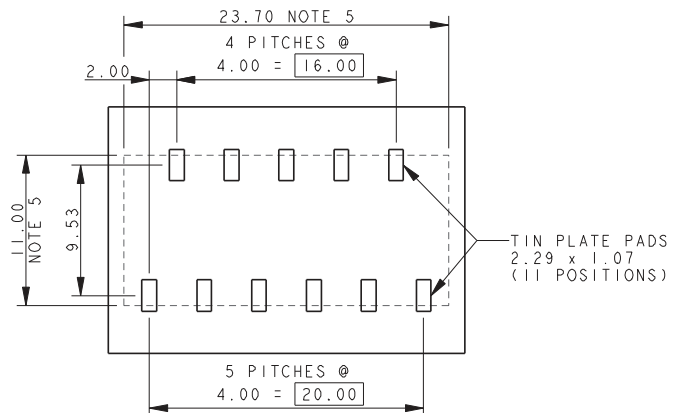
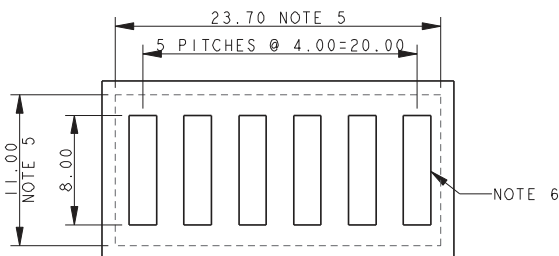

NOTES:

1. GENERAL TOLERANCE ± 0.20 UNLESS OTHERWISE STATED.
2. FOR FURTHER DETAILS REFER TO AVX SPECIFICATION 201-01-207.
3. ADDITIONAL INFORMATION AND BASIC MATING DETAILS REFER TO PAGES 12-14.
4. PACKING DETAILS ON PAGE 15.
5. CONNECTOR OUTLINE.
6. RECOMMENDED PLATING ON MATING PADS. GOLD OVER NICKEL.
7. FOR OTHER TAN VERTICAL MATING WE RECOMMEND MATING WITH THE FIXED CONNECTOR, REFER TO PAGE 13.

Two-Piece 4.0mm Pitch Battery

9155-400

2 WAY BATTERY CONNECTOR – FIXED HALF OPTIONAL

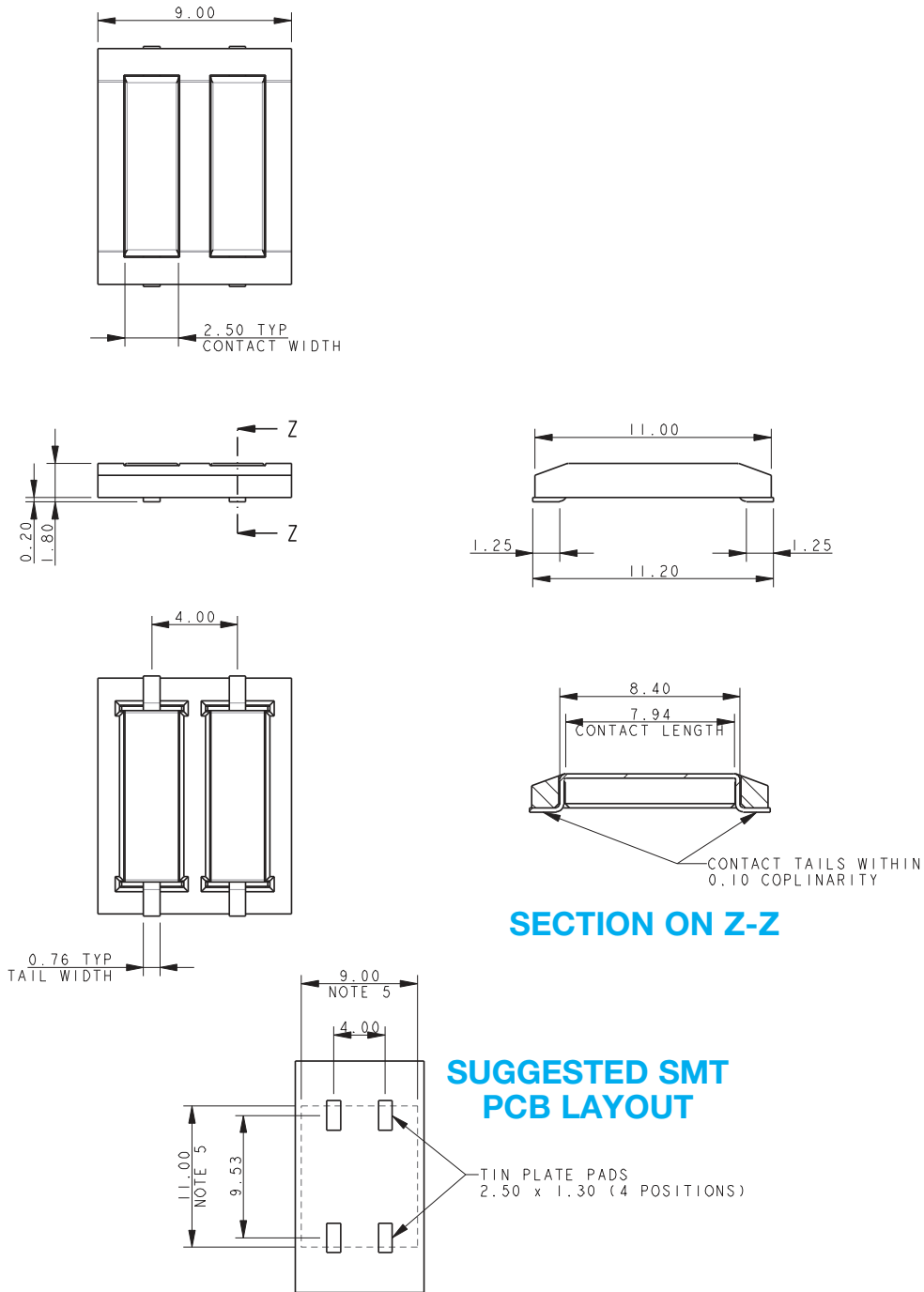

NOTES:

1. GENERAL TOLERANCE ± 0.20 UNLESS OTHERWISE STATED.
2. FOR FURTHER DETAILS REFER TO AVX SPECIFICATION 201-01-207.
3. ADDITIONAL INFORMATION AND BASIC MATING DETAILS REFER TO PAGES 12-13.
4. PACKING DETAILS ON PAGE 15.
5. CONNECTOR OUTLINE.

Two-Piece 4.0mm Pitch Battery

9155-400

3 WAY BATTERY CONNECTOR – FIXED HALF OPTIONAL

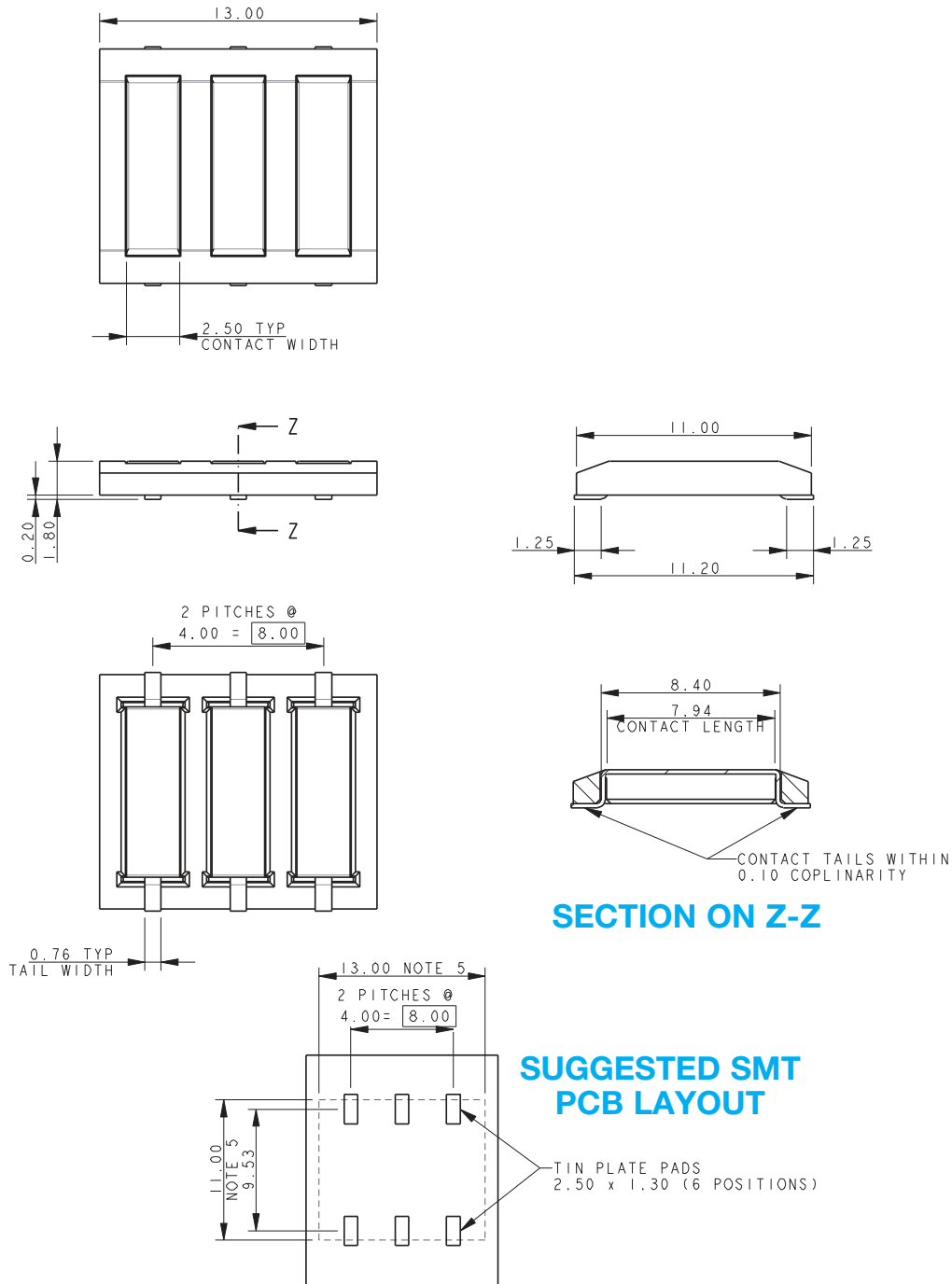

NOTES:

1. GENERAL TOLERANCE ± 0.20 UNLESS OTHERWISE STATED.
2. FOR FURTHER DETAILS REFER TO AVX SPECIFICATION 201-01-207.
3. ADDITIONAL INFORMATION AND BASIC MATING DETAILS REFER TO PAGES 12-13.
4. PACKING DETAILS ON PAGE 15.
5. CONNECTOR OUTLINE.

Two-Piece 4.0mm Pitch Battery

9155-400

4 WAY BATTERY CONNECTOR – FIXED HALF OPTIONAL

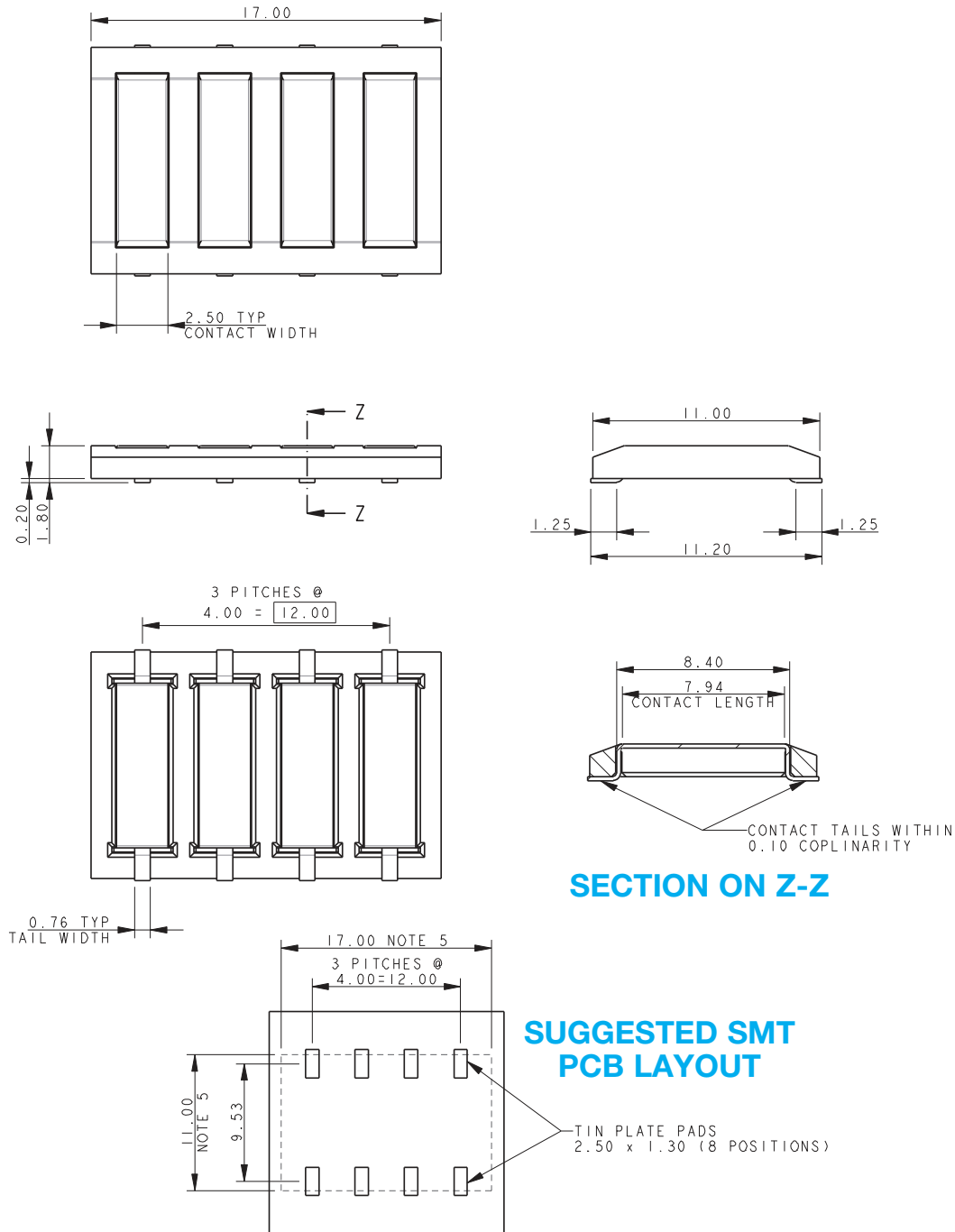

NOTES:

1. GENERAL TOLERANCE ± 0.20 UNLESS OTHERWISE STATED.
2. FOR FURTHER DETAILS REFER TO AVX SPECIFICATION 201-01-207.
3. ADDITIONAL INFORMATION AND BASIC MATING DETAILS REFER TO PAGES 12-13.
4. PACKING DETAILS ON PAGE 15.
5. CONNECTOR OUTLINE.

Two-Piece 4.0mm Pitch Battery

9155-400

5 WAY BATTERY CONNECTOR – FIXED HALF OPTIONAL

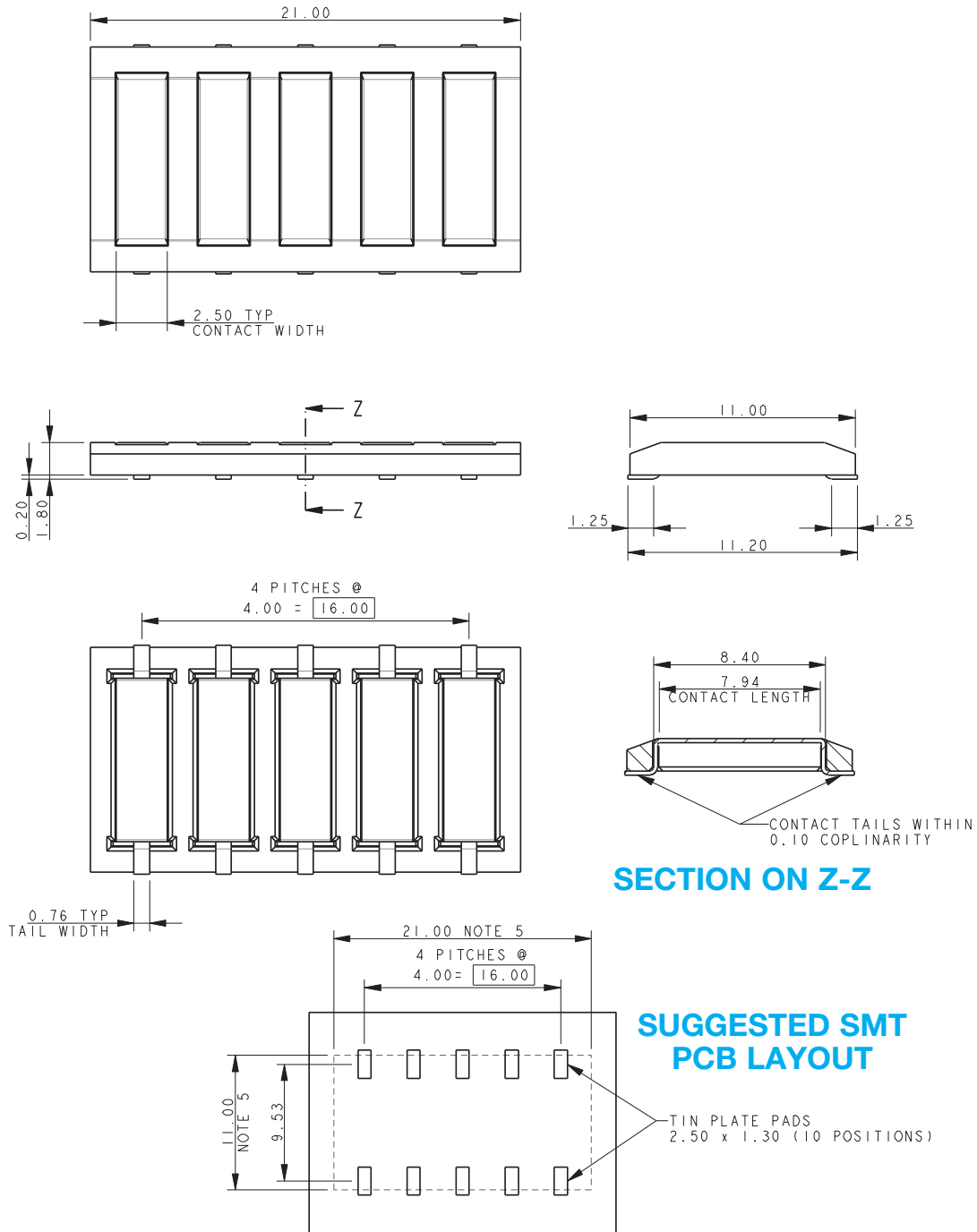

Two-Piece 4.0mm Pitch Battery

9155-400

6 WAY BATTERY CONNECTOR – FIXED HALF OPTIONAL

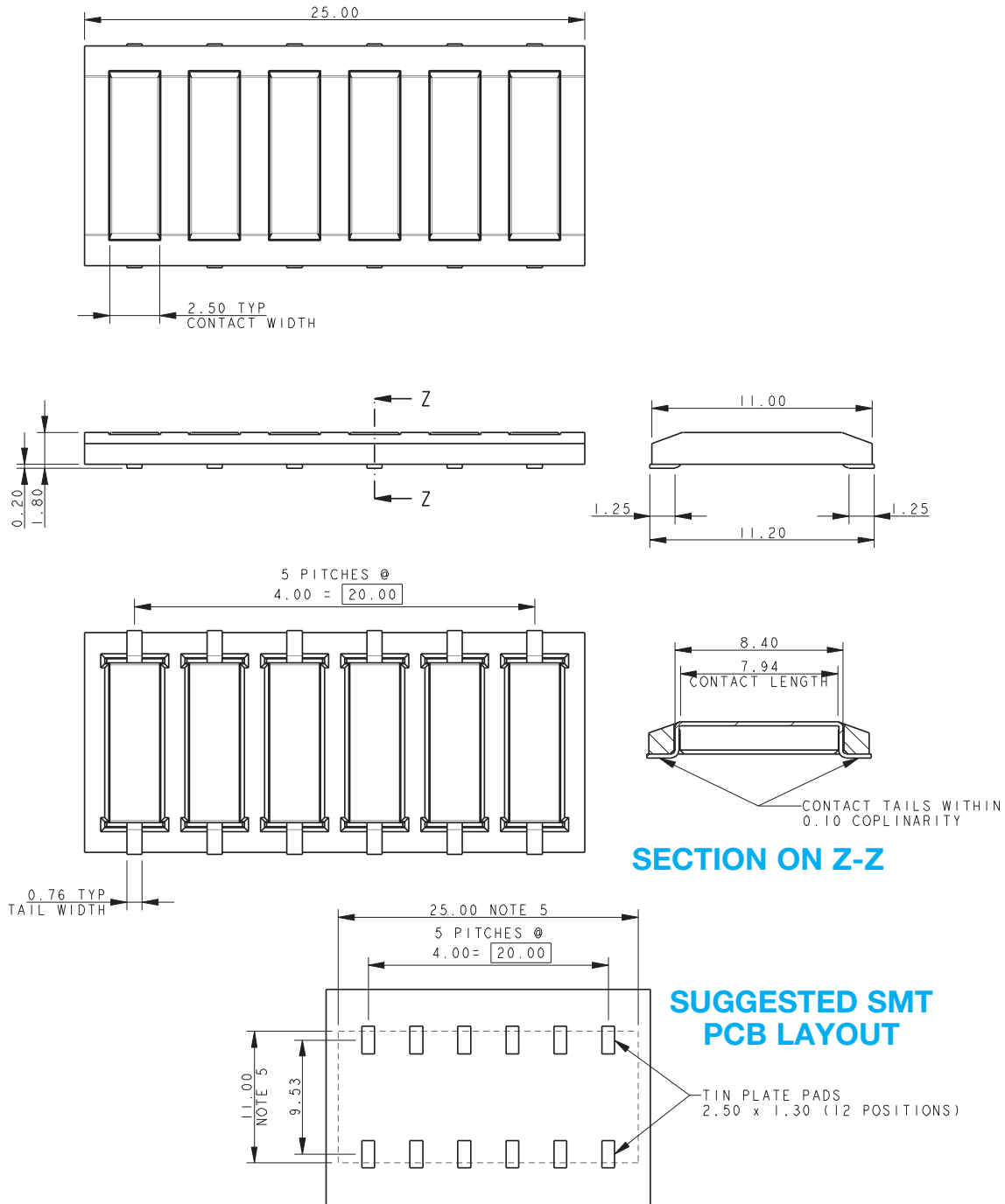

NOTES:

1. GENERAL TOLERANCE ± 0.20 UNLESS OTHERWISE STATED.
2. FOR FURTHER DETAILS REFER TO AVX SPECIFICATION 201-01-207.
3. ADDITIONAL INFORMATION AND BASIC MATING DETAILS REFER TO PAGES 12-13.
4. PACKING DETAILS ON PAGE 15.
5. CONNECTOR OUTLINE.

Two-Piece 4.0mm Pitch Battery

9155-400

BATTERY CONNECTOR - MATING DETAILS SPRUNG HALF MATED WITH FIXED HALF

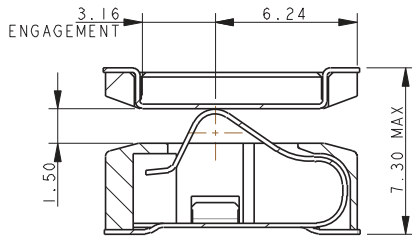

CONNECTOR ASSEMBLY
MAXIMUM GAP

PROJECTED CONTACT FORCE 0.67N

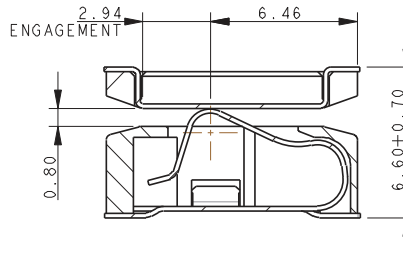

CONNECTOR ASSEMBLY
NOMINAL GAP

PROJECTED CONTACT FORCE 1.23N

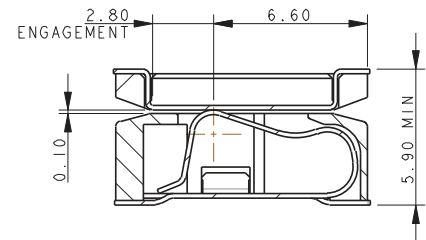

CONNECTOR ASSEMBLY
MINIMUM GAP

PROJECTED CONTACT FORCE 1.70N

NOTES:

1. GENERAL TOLERANCE ± 0.20 UNLESS OTHERWISE STATED.
2. INSULATION MATERIAL: LCP, GLASS FILLED, UL94 V-0, COLOR BLACK.
3. CONTACT MATERIAL SPRUNG HALF: BERYLLIUM COPPER.
4. CONTACT MATERIAL FIXED HALF: PHOSPHOR BRONZE.
5. CONTACT PLATING: GOLD OVER NICKEL, PURE TIN TAILS.
6. DURABILITY 5000 OPERATIONS.
7. CURRENT RATING 5A.
8. CONTACT RESISTANCE 25m Ω MAX.

BATTERY CONNECTOR - MATING DETAILS DIRECTION OF MATING

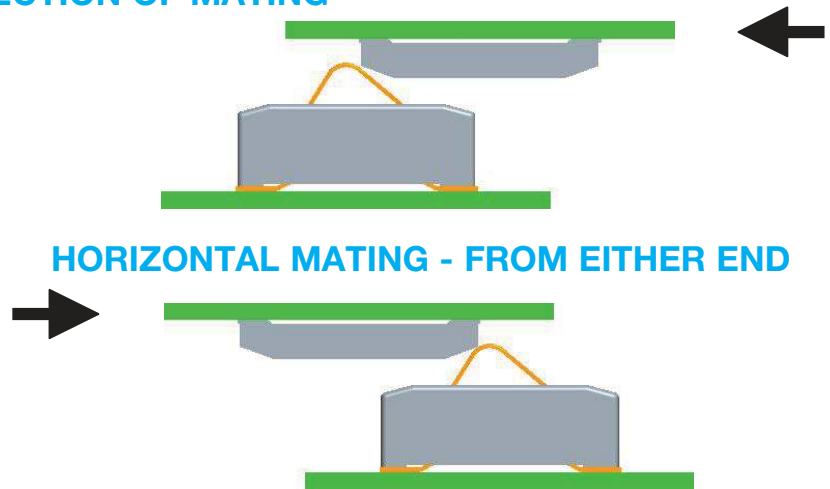
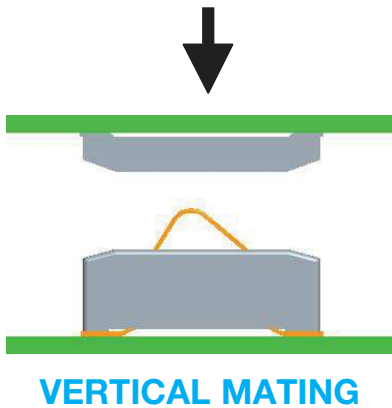

BATTERY CONNECTOR - MATING DETAILS SPRUNG HALF MATED WITH PCB

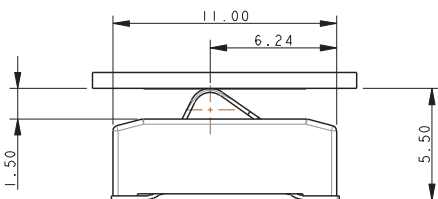

CONNECTOR ASSEMBLY
MAXIMUM GAP

PROJECTED CONTACT FORCE 0.67N

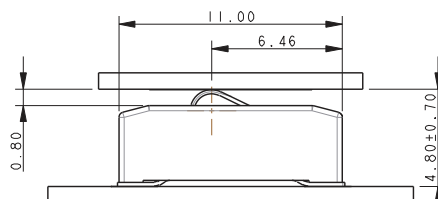

CONNECTOR ASSEMBLY
NOMINAL GAP

PROJECTED CONTACT FORCE 1.23N

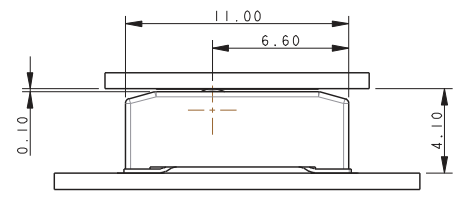

CONNECTOR ASSEMBLY
MINIMUM GAP

PROJECTED CONTACT FORCE 1.70N

NOTES:

1. GENERAL TOLERANCE ± 0.20 UNLESS OTHERWISE STATED.
2. SPRUNG HALF MATED WITH GOLD PLATED PAD ON PCB
3. VERTICAL MATING ONLY.

Two-Piece 4.0mm Pitch Battery

9155-400

BI-DIRECTIONAL BATTERY CONNECTOR - PACKING DETAILS

PACKING DETAILS SPRUNG CONNECTOR

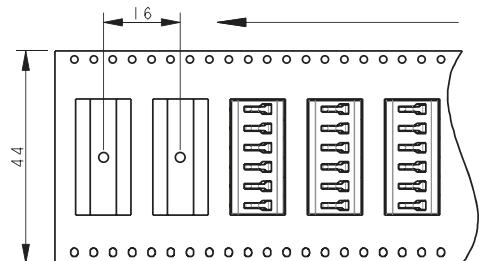
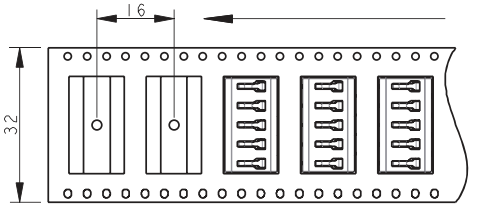
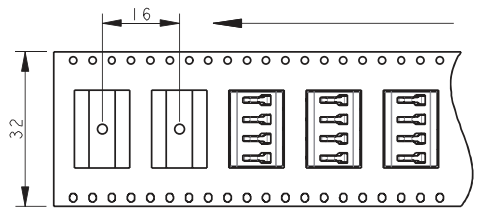
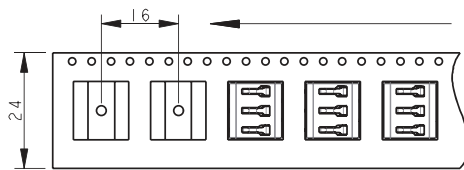
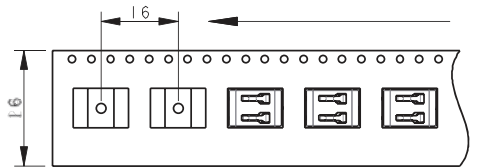

REEL QTY	550
LEADER	500mm
TRAILER	500mm

PACKING DETAILS FIXED CONNECTOR

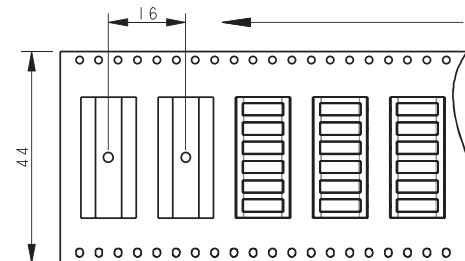
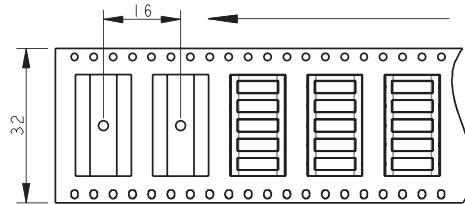
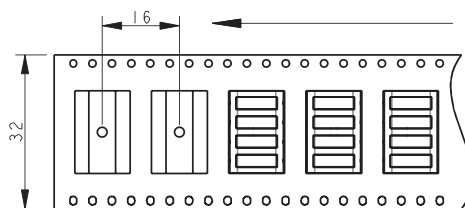
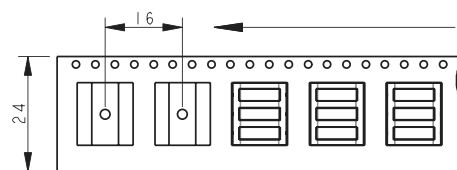
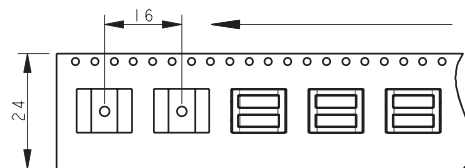

REEL QTY	1100
LEADER	500mm
TRAILER	500mm

UNREELED
DIRECTION

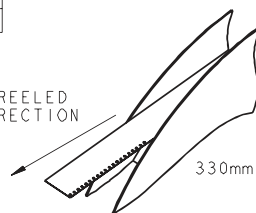

330mm DIAMETER REEL