

MATERIAL NUMBER	ALTERNATE NUMBER	STUD SIZES	"S"
190670315	H-980-12	12	.198
190670101	H-980-38	3/8	.390
190670102	H-980-76	7/16	.453

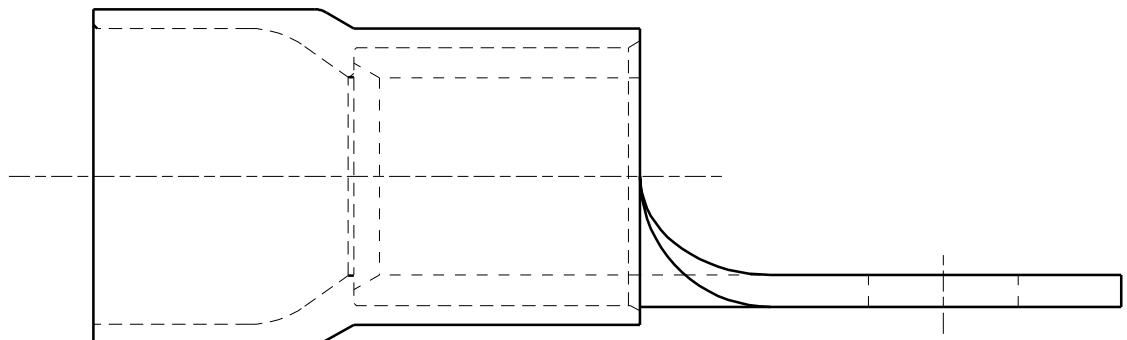
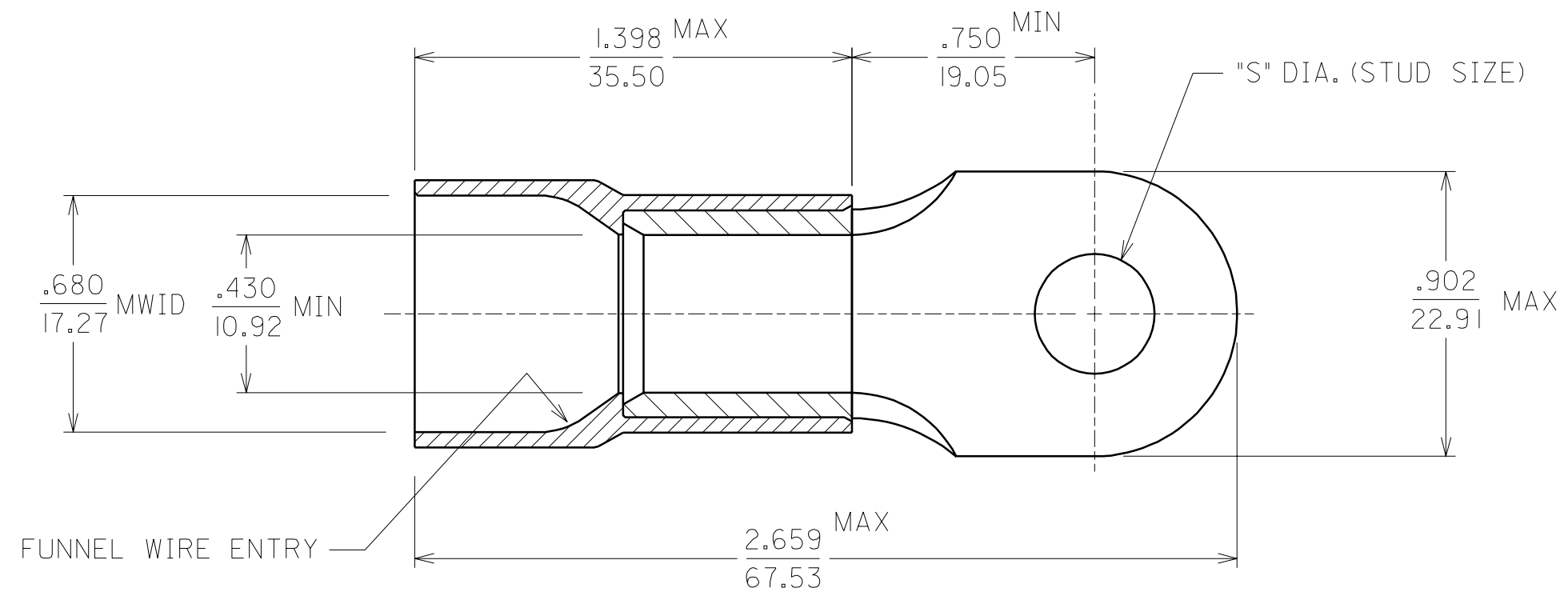

NOTES:
 1. MATERIAL: COPPER .075 THICK
 PLATING: ELECTROPLATE TIN
 2. INSULATION: BLUE NYLON 6/6
 3. MWID=MAXIMUM WIRE INSULATION DIA.
 4. ALL DIMENSIONS IN INCHES/(MM).

A	NEW CUST DGN ETC2001-0251 01/02/27 EDB
LTR.	REVISIONS

CUSTOMER DRAWING

DIMENSIONS SHOWN (METRIC) INCH		REVISE ONLY ON CAD SYSTEM																			
UNLESS OTHERWISE SPECIFIED TOLERANCES: ANGULAR ± 1/2°		TITLE NYLAKRIMP FUNNEL ENTRY RING TONGUE TERMINAL 1/0 AWG																			
<table border="1"> <thead> <tr> <th></th> <th>INCH</th> <th>METRIC</th> </tr> </thead> <tbody> <tr> <td>3 PLACE</td> <td>± .005</td> <td>± ---</td> </tr> <tr> <td>2 PLACE</td> <td>± .01</td> <td>± 0.13</td> </tr> <tr> <td>1 PLACE</td> <td>± ---</td> <td>± 0.25</td> </tr> </tbody> </table>			INCH	METRIC	3 PLACE	± .005	± ---	2 PLACE	± .01	± 0.13	1 PLACE	± ---	± 0.25	<table border="1"> <tr> <td>molex ETC INC.</td> <td>SHEET NO.</td> <td>DATE</td> </tr> <tr> <td>PINELLAS PARK, FLA. 33781 U.S.A.</td> <td>1 OF 1</td> <td>01/02/02</td> </tr> </table>		molex ETC INC.	SHEET NO.	DATE	PINELLAS PARK, FLA. 33781 U.S.A.	1 OF 1	01/02/02
	INCH	METRIC																			
3 PLACE	± .005	± ---																			
2 PLACE	± .01	± 0.13																			
1 PLACE	± ---	± 0.25																			
molex ETC INC.	SHEET NO.	DATE																			
PINELLAS PARK, FLA. 33781 U.S.A.	1 OF 1	01/02/02																			
DRAFT WHERE APPLICABLE MUST REMAIN WITHIN DIMENSIONS		PART NO. SEE CHART																			
<table border="1"> <tr> <td>DRWG. BY</td> <td>EDB</td> <td>CHK'D. BY</td> <td>HEB</td> </tr> <tr> <td>APP'D. BY</td> <td>RWD</td> <td>SCALE</td> <td>NO:NE</td> </tr> </table>		DRWG. BY	EDB	CHK'D. BY	HEB	APP'D. BY	RWD	SCALE	NO:NE	<table border="1"> <tr> <td>DRWG. NO.</td> <td>SD-19067-006</td> </tr> <tr> <td>FILE NAME</td> <td>SD19067006 DGN</td> </tr> <tr> <td colspan="2">THIS DRAWING CONTAINS INFORMATION THAT IS PROPRIETARY TO MOLEX-ETC INC. AND SHOULD NOT BE USED WITHOUT WRITTEN PERMISSION.</td> </tr> <tr> <td>DIV.</td> <td>ET</td> </tr> <tr> <td>SIZE</td> <td>B</td> </tr> </table>		DRWG. NO.	SD-19067-006	FILE NAME	SD19067006 DGN	THIS DRAWING CONTAINS INFORMATION THAT IS PROPRIETARY TO MOLEX-ETC INC. AND SHOULD NOT BE USED WITHOUT WRITTEN PERMISSION.		DIV.	ET	SIZE	B
DRWG. BY	EDB	CHK'D. BY	HEB																		
APP'D. BY	RWD	SCALE	NO:NE																		
DRWG. NO.	SD-19067-006																				
FILE NAME	SD19067006 DGN																				
THIS DRAWING CONTAINS INFORMATION THAT IS PROPRIETARY TO MOLEX-ETC INC. AND SHOULD NOT BE USED WITHOUT WRITTEN PERMISSION.																					
DIV.	ET																				
SIZE	B																				