

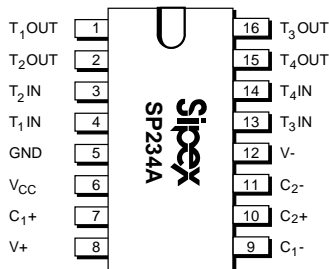

SP230A/234A/235A/236A/237A/238A/241A SP235B/236B/240A/240B/241A/241B

+5V Powered Multi-Channel RS-232 Drivers/Receivers

- Operates from Single +5V Power Supply
- Meets All RS-232D and V.28 Specifications
- $\pm 9V$ Output Swing with +5V Supply
- Improved Driver Output Capacity for Mouse Applications
- Low Power Shutdown – $1\mu A$
- WakeUp Feature in Shutdown Mode
- 3–State TTL/CMOS Receiver Outputs
- $\pm 30V$ Receiver Input Levels
- Low Power CMOS – 5mA Operation
- Wide Charge Pump Capacitor Value Range – 1-10 μF



Now Available in Lead Free Packaging

DESCRIPTION...

The **SP230A** Series are multi-channel RS-232 line drivers/receivers that provide a variety of configurations to fit most communication needs, especially where $\pm 12V$ is not available. Some models feature a shutdown mode to conserve power in battery-powered systems. Some require no external components. All, except one model, feature a built-in charge pump voltage converter, allowing them to operate from a single +5V power supply. All drivers and receivers meet all EIA RS-232D and CCITT V.28 requirements. The Series is available in plastic DIP and SOIC packages.

SELECTION TABLE

| Model | Power Supplies | No. of RS-232 Drivers | No. of RS-232 Rcvrs | External Components | Low Power Shutdown | TTL 3–State | Wake-Up | No. of Pins |
|--------|----------------|-----------------------|---------------------|---------------------|--------------------|-------------|---------|-------------|
| SP230A | +5V | 5 | 0 | 4 Capacitors | Yes | No | No | 20 |
| SP234A | +5V | 4 | 0 | 4 Capacitors | No | No | No | 16 |
| SP235A | +5V | 5 | 5 | None | Yes | Yes | No | 24 |
| SP235B | +5V | 5 | 5 | None | Yes | Yes | Yes | 24 |
| SP236A | +5V | 4 | 3 | 4 Capacitors | Yes | Yes | No | 24 |
| SP236B | +5V | 4 | 3 | 4 Capacitors | Yes | Yes | Yes | 24 |
| SP237A | +5V | 5 | 3 | 4 Capacitors | No | No | No | 24 |
| SP238A | +5V | 4 | 4 | 4 Capacitors | No | No | No | 24 |
| SP240A | +5V | 5 | 5 | 4 Capacitors | Yes | Yes | No | 44 |
| SP240B | +5V | 5 | 5 | 4 Capacitors | Yes | Yes | Yes | 44 |
| SP241A | +5V | 4 | 5 | 4 Capacitors | Yes | Yes | No | 28 |
| SP241B | +5V | 4 | 5 | 4 Capacitors | Yes | Yes | Yes | 28 |

ABSOLUTE MAXIMUM RATINGS

This is a stress rating only and functional operation of the device at these or any other conditions above those indicated in the operation sections of this specification is not implied. Exposure to absolute maximum rating conditions for extended periods of time may affect reliability.

| | |
|-----------------|-----------------------------|
| V_{CC} | +6V |
| V^- | ($V_{CC}-0.3V$) to +13.2V |
| V^- | 13.2V |
| Input Voltages: | |
| T_{IN} | -0.3 to ($V_{CC}+0.3V$) |
| R_{IN} | $\pm 30V$ |

| | |
|-------------------------------|--------------------------------------|
| Output Voltages: | |
| T_{OUT} | (V^+ , +0.3V) to (V^- , -0.3V) |
| R_{OUT} | -0.3V to ($V_{CC}+0.3V$) |
| Short Circuit Duration: | |
| T_{OUT} | Continuous |
| Power Dissipation: | |
| CERDIP | 675mW |
| (derate 9.5mW/°C above +70°C) | |
| Plastic DIP | 375mW |
| (derate 7mW/°C above +70°C) | |
| Small Outline | 375mW |
| (derate 7mW/°C above +70°C) | |

ELECTRICAL CHARACTERISTICS

All units $V_{CC}=+5V\pm 10\%$; except SP235A/B, $V_{CC}=+5V\pm 5\%$; All specifications T_{MIN} to T_{MAX} unless otherwise noted.

| PARAMETERS | MIN. | TYP. | MAX. | UNITS | CONDITIONS |
|-------------------------------------|---------|----------|----------|------------|---|
| POWER REQUIREMENTS | | | | | |
| V_{CC} Power Supply Current | | 5 | 10 | mA | No load, $T_A = +25^\circ C$ |
| Shutdown Supply Current | | 1 | 10 | μA | $T_A = +25^\circ C$ |
| LOGIC INPUTS | | | | | |
| Input Logic Threshold | | | | | |
| Low | | | 0.8 | Volts | $T_{IN} ; EN, SD$ |
| High | 2.0 | | | Volts | $T_{IN} ; EN, SD$ |
| Logic Pullup Current | | 15 | 200 | μA | $T_{IN} = \underline{0V}$ |
| RS-232 INPUTS | | | | | |
| RS-232 Input Voltage Range | -30 | | +30 | Volts | |
| RS-232 Input Threshold | | | | | |
| Low | 0.8 | 1.2 | | Volts | $V_{CC} = 5V, T_A = +25^\circ C$ |
| High | | 1.7 | 2.4 | Volts | $V_{CC} = 5V, T_A = +25^\circ C$ |
| RS-232 Input Hysteresis | 0.2 | 0.5 | 1.0 | Volts | $V_{CC} = 5V$ |
| RS-232 Input Resistance | 3 | 5 | 7 | kOhms | $T_A = +25^\circ C, -15V \leq V_{IN} \leq +15V$ |
| LOGIC OUTPUTS | | | | | |
| Output Voltage | | | | | |
| Low | | | 0.4 | Volts | $I_{OUT} = 3.2mA$ |
| High | 3.5 | | | Volts | $I_{OUT} = 1.0mA$ |
| Output Leakage Current | | 0.05 | ± 10 | μA | $EN = V_{CC}, 0V \leq V_{OUT} \leq V_{CC}$ |
| RS-232 OUTPUTS | | | | | |
| Output Enable Time | | 400 | | ns | SP235A/B, SP236A/B, SP241A/B |
| Output Disable Time | | 250 | | ns | SP235A/B, SP236A/B, SP241A/B |
| Propagation Delay | | 1.5 | | μs | RS232 to TTL |
| Instantaneous Slew Rate | | | 30 | V/ μs | $C_L = 10pF, R_L = 3-7k\Omega; T_A = +25^\circ C$ |
| RS-232 OUTPUTS | | | | | |
| Transition Region Slew Rate | | 3 | | V/ μs | $C_L = 2500pF, R_L = 3k\Omega;$ measured from +3V to -3V or -3V to +3V |
| Output Voltage Swing | ± 5 | ± 9 | | Volts | All transmitter outputs loaded with 3k Ω to Ground |
| Output Resistance | 300 | | | Ohms | $V_{CC} = 0V; V_{OUT} = \pm 2V$ |
| RS-232 Output Short Circuit Current | | ± 10 | | mA | Infinite duration |

Transmitter Output Waveforms

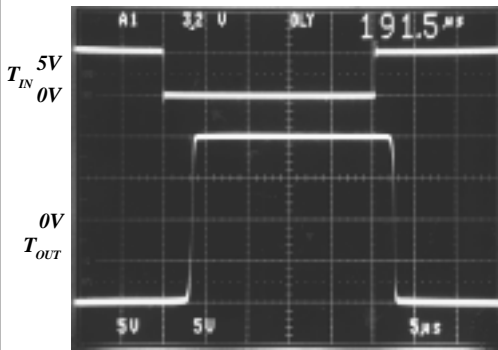

No load

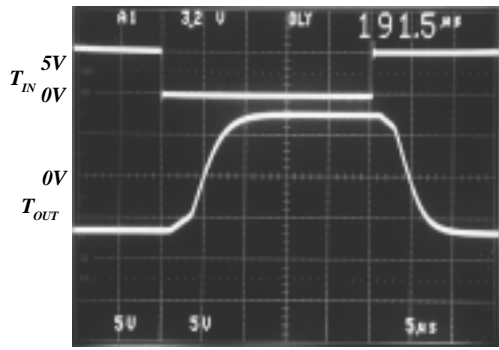

$R_L = 3k\Omega$, $C_L = 2,500pF$

Transmitter Propagation Delay

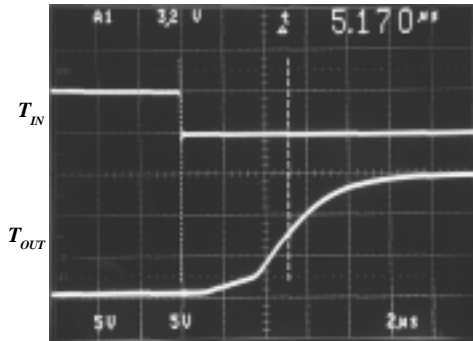

Rise Time
 $R_L = 3k\Omega$; $C_L = 2,500pF$
 All inputs = 20kHz

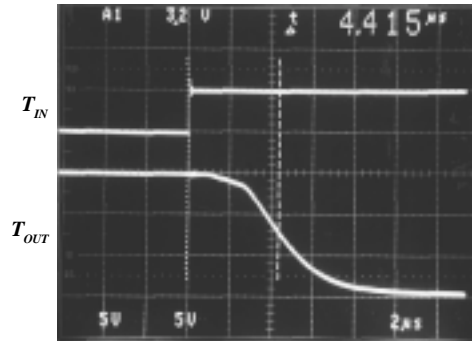

Fall Time
 $R_L = 3k\Omega$; $C_L = 2,500pF$

Receiver Output Waveform

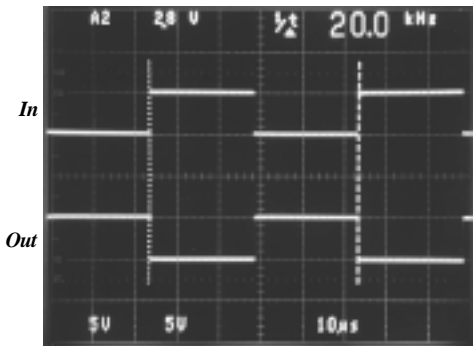

Shutdown to V+, V- Rise Time

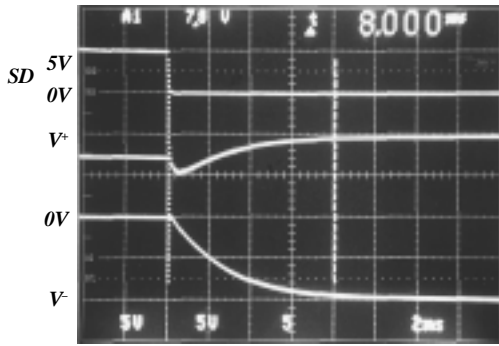

Receiver Propagation Delay

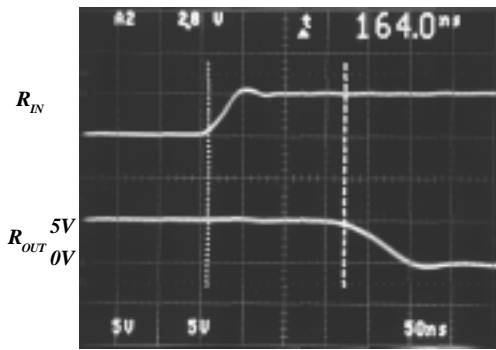

Fall Time

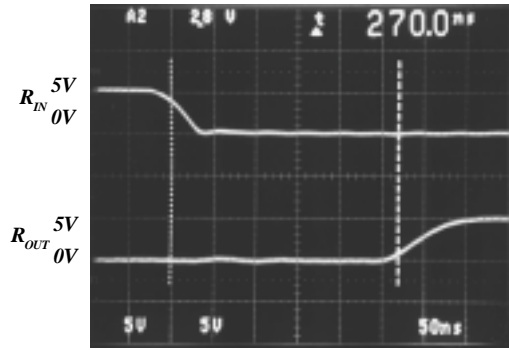

Rise Time

PINOUT

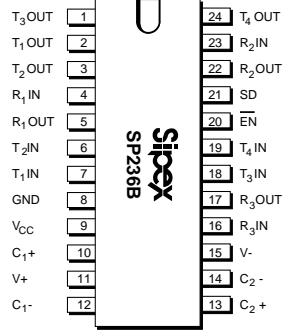
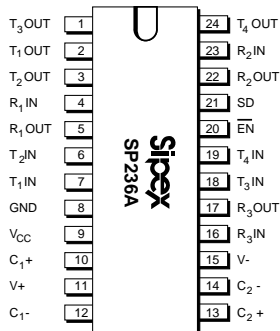
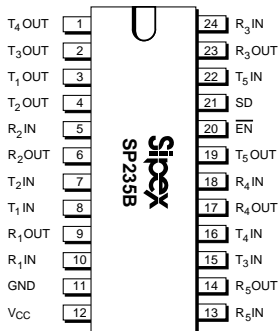
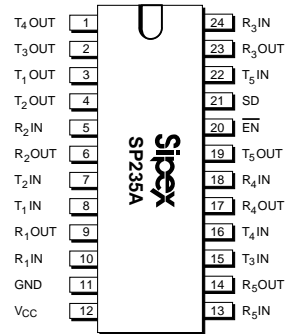
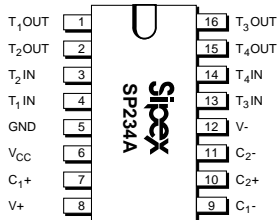
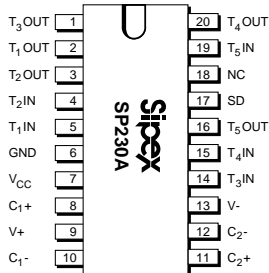

Receiver Output Enable/Disable Times

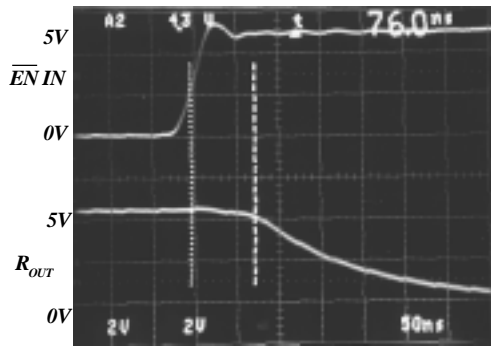

Disable

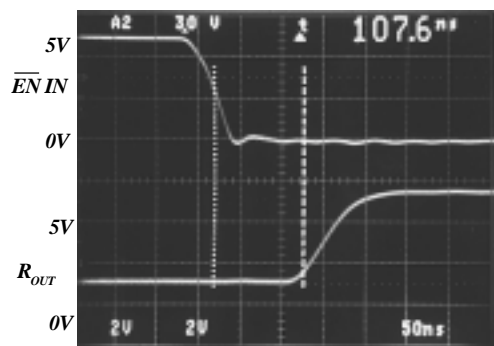

Enable

PINOUT

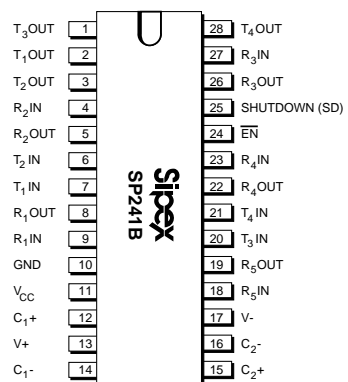
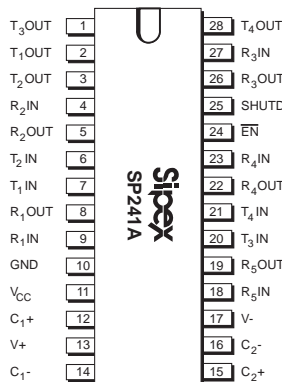
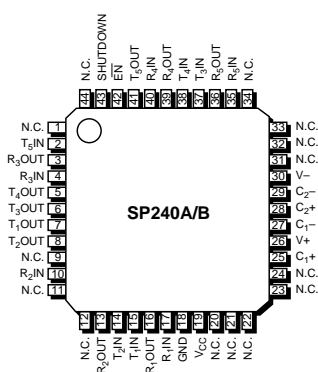
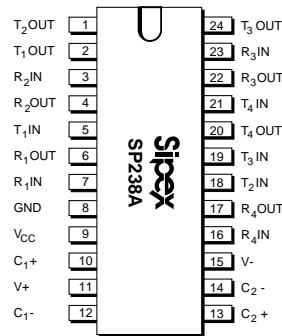
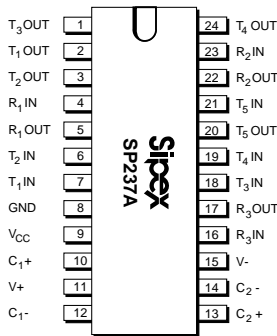

FEATURES...

The multi-channel RS-232 line drivers/receivers provides a variety of configurations to fit most communication needs, especially those applications where $\pm 12V$ is not available. The **SP230A**, **SP235A/B**, **SP236A/B**, **SP240A/B**, and **SP241A/B** feature a shutdown mode which reduces device power dissipation to less than $5\mu W$. All feature low power CMOS operation, which is particularly beneficial in battery-powered systems. The **SP235A/B** use no external components and are ideally suited where printed circuit board space is limited.

All products in the Series include two charge pump voltage converters which allow them to operate from a single +5V supply. These converters convert the +5V input power to the $\pm 10V$ needed to generate the RS-232 output levels. An internal charge pump converter produces the necessary $-12V$ supply. All drivers and receivers meet all EIA RS-232D and CCITT V.28 specifications.

The Series are available for use over the commercial, industrial and military temperature ranges. They are packaged in plastic DIP and SOIC packages. For product processed and screened to MIL-M-38510 and MIL-STD-883C requirements, please consult the factory.

THEORY OF OPERATION

The **SP230A/B-241A/B** series devices are made up of three basic circuit blocks—1) transmitter, 2) receiver and 3) charge pump. Each model within the series incorporates variations of these circuits to achieve the desired configuration and performance.

Driver/Transmitter

The drivers are inverting transmitters, which accept TTL or CMOS inputs and output the RS-232 signals with an inverted sense relative to the input logic levels. Typically the RS-232 output voltage swing is $\pm 9V$. Even under worst-case loading conditions of $3k\Omega$ and $2500pF$, the output is guaranteed to be $\pm 5V$, which is consistent with the RS-232 standard specifications. The transmitter outputs are protected against infinite short-circuits to ground without degradation in reliability.

The drivers of the **SP230A**, **SP235A/B**, **SP236A/B**, **SP240A/B** and **SP241A/B** can be tri-stated by using the SHUTDOWN function. In this “power-off” state, the output impedance will remain greater than 300Ω , again satisfying the RS-232 specifications. Should the input of the driver be left open, an internal $400k\Omega$ pull-up resistor to V_{CC} forces the input high, thus committing the output to a low state.

The slew rate of the transmitter output is internally limited to a maximum of $30V/\mu s$ in order to meet the

| Specification | RS-232D | RS-423A | RS-422 | RS-485 | RS-562 | |
|--|--------------------------|--------------------------|--------------------------|----------------------------|--|-------------|
| Mode of Operation | Single-Ended | Single-Ended | Differential | Differential | Single-Ended | |
| Number of Drivers and Receivers Allowed on One Line | 1 Driver 1 Receiver | 1 Driver 10 Receivers | 1 Driver 10 Receivers | 32 Drivers 32 Receivers | 1 Driver 1 Receiver | |
| Maximum Cable Length | 50 feet | 4,000 feet | 4,000 feet | 4,000 feet | $C \leq 2500pF$ @ $\leq 20kb/s$ $C \leq 1000pF$ @ $\geq 20kb/s$ | |
| Maximum Data Rate | 20kbps | 100kbps | 10Mbps | 10Mbps | 64kbps | |
| Driver Output Maximum Voltage | $\pm 25V$ | $\pm 6V$ | $-0.25V$ to $+6V$ | $-7V$ to $+12V$ | -3.7 to $+13.2V$ | |
| Driver Output Signal Level | Loaded | $\pm 5V$ | $\pm 3.6V$ | $\pm 2V$ | $\pm 1.5V$ | $\pm 3.7V$ |
| | Unloaded | $\pm 15V$ | $\pm 6V$ | $\pm 5V$ | $\pm 5V$ | $\pm 13.2V$ |
| Driver Load Impedance | $3k\Omega$ to $7k\Omega$ | 450Ω min. | 100Ω | 54Ω | $3k\Omega$ to $7k\Omega$ | |
| Maximum Driver Output Current (High Impedance State) | Power On | — | — | $\pm 100\mu A$ | — | |
| | Power Off | $V_{MAX} / 300$ | $100\mu A$ | $\pm 100\mu A$ | $\pm 100\mu A$ | — |
| Slew Rate | $30V/\mu s$ max. | Controls Provided | — | — | $30V/\mu s$ max. | |
| Receiver Input Voltage Range | $\pm 15V$ | $\pm 12V$ | $-7V$ to $+7V$ | $-7V$ to $+12V$ | $\pm 15V$ | |
| Receiver Input Sensitivity | $\pm 3V$ | $\pm 200mV$ | $\pm 200mV$ | $\pm 200mV$ | $\pm 3V$ | |
| Receiver Input Resistance | $3k\Omega$ to $7k\Omega$ | $4k\Omega$ min. | $4k\Omega$ min. | $12k\Omega$ min. | $3k\Omega$ to $7k\Omega$ | |

Table 1. EIA Standards Definition

standards [EIA RS-232–D 2.1.7, Paragraph (5)]. The transition of the loaded output from V_{OL} to V_{OH} clearly meets the monotonicity requirements of the standard [EIA RS-232–D 2.1.7, Paragraphs (1) & (2)].

Receivers

The receivers convert RS-232 input signals to inverted TTL signals. Since the input is usually from a transmission line, where long cable lengths and system interference can degrade the signal, the inputs have a typical hysteresis margin of 500mV. This ensures that the receiver is virtually immune to noisy transmission lines.

The input thresholds are 0.8V minimum and 2.4V maximum, again well within the $\pm 3V$ RS-232 requirements. The receiver inputs are also protected against voltages up to $\pm 30V$. Should an input be left unconnected, a 5k Ω pull-down resistor to ground will commit the output of the receiver to a high state.

In actual system applications, it is quite possible for signals to be applied to the receiver inputs before power is applied to the receiver circuitry. This occurs, for example, when a PC user attempts to print, only to realize the printer wasn't turned on. In this case an RS-232 signal from the PC will appear on the receiver input at the printer. When the printer power is turned on, the receiver will operate normally. All series devices are fully protected. Again, to facilitate use in "real-world" applications, the receiver outputs can be tri-stated by bringing the ENABLE (\overline{EN}) pin high, with the driver remaining full active.

Charge Pump

The charge pump section of the **SP230A** series allows the circuit to operate from a single +5V, $\pm 10\%$ power

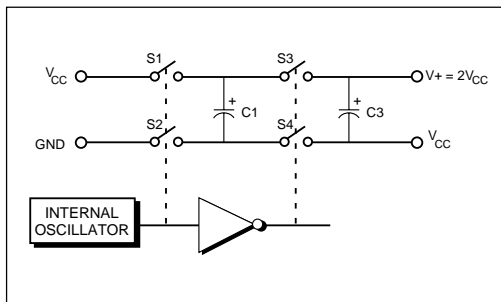

Figure 1. Charge Pump Voltage Doubler

supply by generating the required operating voltages internal to the devices. The charge pump consists of two sections — 1) a voltage doubler and 2) a voltage inverter.

As shown in *Figure 1*, an internal oscillator triggers the charge accumulation and voltage inversion. The voltage doubler momentarily stores a charge on capacitor C_1 equal to V_{CC} , reference to ground. During the next transition of the oscillator this charge is boot-strapped to transfer charge to capacitor C_3 . The voltage across C_3 is now from V_{CC} to V^+ .

In the inverter section (*Figure 2*), the voltage across C_3 is transferred to C_2 forcing a range of 0V to V^+ across C_2 . Boot-strapping of C_2 will then transfer charge to C_4 to generate V^- .

The values of the capacitors are somewhat non-critical and can be varied, however the performance will be affected. As C_3 and C_4 are reduced, higher levels of ripple will appear. Lower values of C_1 and C_2 will increase the

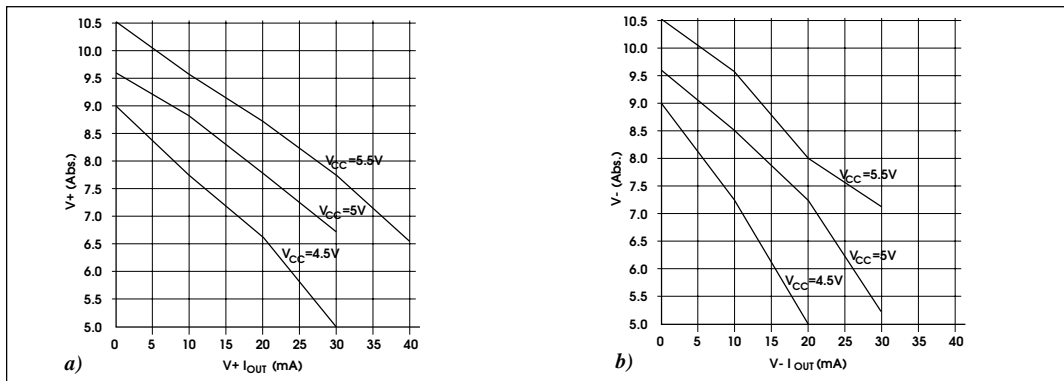

Charge Pump Output Loading versus VCC; a) V^+ ; b) V^-

| SD | $\overline{\text{EN}}$ | Power Up/Down | Receiver Outputs |
|----|------------------------|---------------|------------------|
| 0 | 0 | Up | Enable |
| 0 | 1 | Up | Tri-state |
| 1 | 0 | Down | Enable |
| 1 | 1 | Down | Tri-state |

Table 2. Wake-Up Truth Table

output impedance of V^+ and V^- , which will degrade V_{OH} and V_{OL} . Capacitor values can be as low as $1.0\mu\text{F}$.

Shutdown (SD)

The **SP230A**, **SP235A/B**, **SP236A/B**, **SP240A/B** and **SP241A/B** all feature a control input which will disable the part and reduce V_{CC} current typically to less than $5\mu\text{A}$, which is especially useful to designers of battery-powered systems. In the “power-off” mode the receiver and transmitter will both be tri-stated. V^+ will discharge to V_{CC} , and V^- will discharge to ground.

For complete shutdown to occur and the $10\mu\text{A}$ current drain to be realized, the following conditions must be met:

- +5.00V must be applied to the SD pin;
- ENABLE must either 0V, +5.0V or not connected;
- the transmitter inputs must be either +5.0V or not connected;
- V_{CC} must be +5V;
- Receiver inputs must be $>0\text{V}$ and $<+5\text{V}$

Please note that for proper operation, the SD input pin must never be left floating.

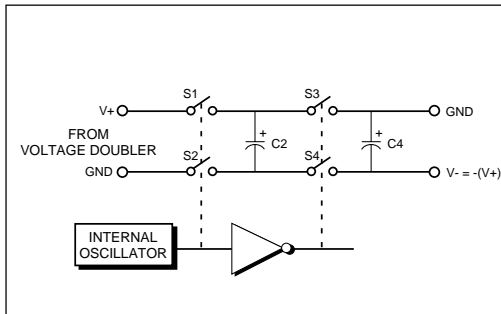

Figure 2. Charge Pump Voltage Inverter

ENABLE Input ($\overline{\text{EN}}$)

The **SP235A/B**, **SP236A/B**, **SP240A/B**, and **SP241A/B** all feature an enable input ($\overline{\text{EN}}$), which allows the receiver outputs to be either tri-stated or enabled. The enable input is active low; 0V applied to $\overline{\text{EN}}$ will enable the receiver outputs. This can be especially useful when the receiver is tied directly to a microprocessor data bus.

Protection From Shorts to $>\pm 15\text{V}$

The driver outputs are protected against shorts to ground, other driver outputs, and V^+ or V^- . For protection against voltages exceeding $\pm 15\text{V}$, two back-to-back zener diodes connected to clamp the outputs to an acceptable voltage level are recommended. (Refer to Figure 3.)

Improved Drive Capability for Mouse Applications

Each of the devices in this data sheet have improved drive capability for non-standard applications. Although the EIA RS-232D standards specify the maximum loading to be $3\text{k}\Omega$ and 2500pF , the **SP230A**, **SP234A**, **SP235A/B**, **SP236A/B**, **SP237A**, **SP238A**, **SP240A/B**, and **SP241A/B** can typically drive loads as low as $1\text{k}\Omega$ and still maintain $\pm 5\text{V}$ outputs. This feature is especially useful when the serial port is intended to be used for a “self-powered” mouse. In this case the voltage necessary to operate the circuits in the mouse can be derived from the RS-232 driver output as long as the loading is $\geq 1\text{k}\Omega$ (refer to Figure 4). For applications which even exceed this requirement, drivers can be connected in parallel, increasing the drive capability to 750Ω , while maintaining the $\pm 5\text{V}$ V_{OH} and V_{OL} levels (refer to Figure 5).

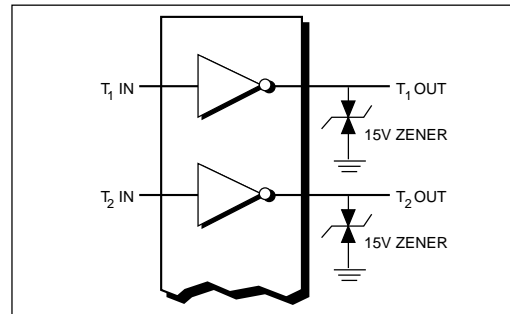

Figure 3. High Voltage Short Circuit Protection

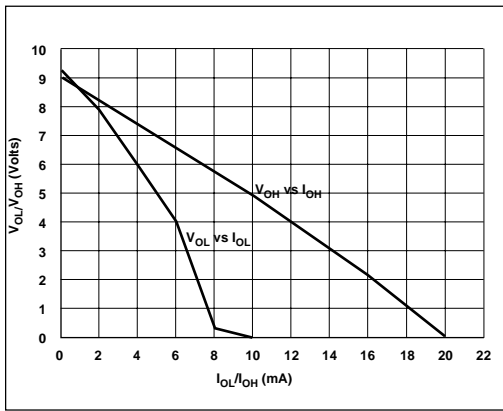

Figure 4. Mouse Application Drive Capability

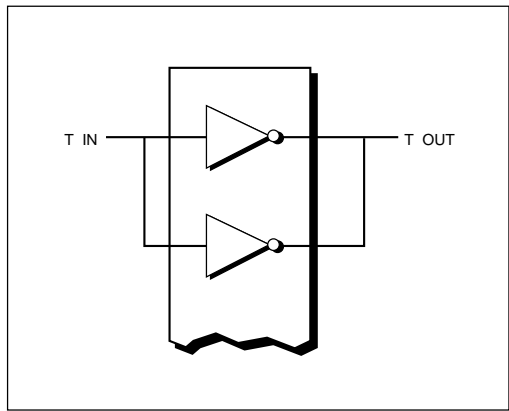

Figure 5. Parallel Drivers

Wake-Up Feature

The **SP235B**, **SP236B**, **SP240B** and **SP241B** have a wake-up feature that keeps all receivers in an enabled state when the device is in the shutdown mode. *Table 2* defines the truth table for the wake-up function. Timing for the wake-up function is shown in *Figure 6*.

If the **SP235B**, **SP236B**, **SP240B** and **SP241B** are powered up in the shutdown state (SD driven high during V_{CC} power up), the part must remain in a powered on state for a minimum of 3ms before the wake-up function can be used. After the 3ms wait time, there is a 2ms delay time before data is valid for both enable and disable

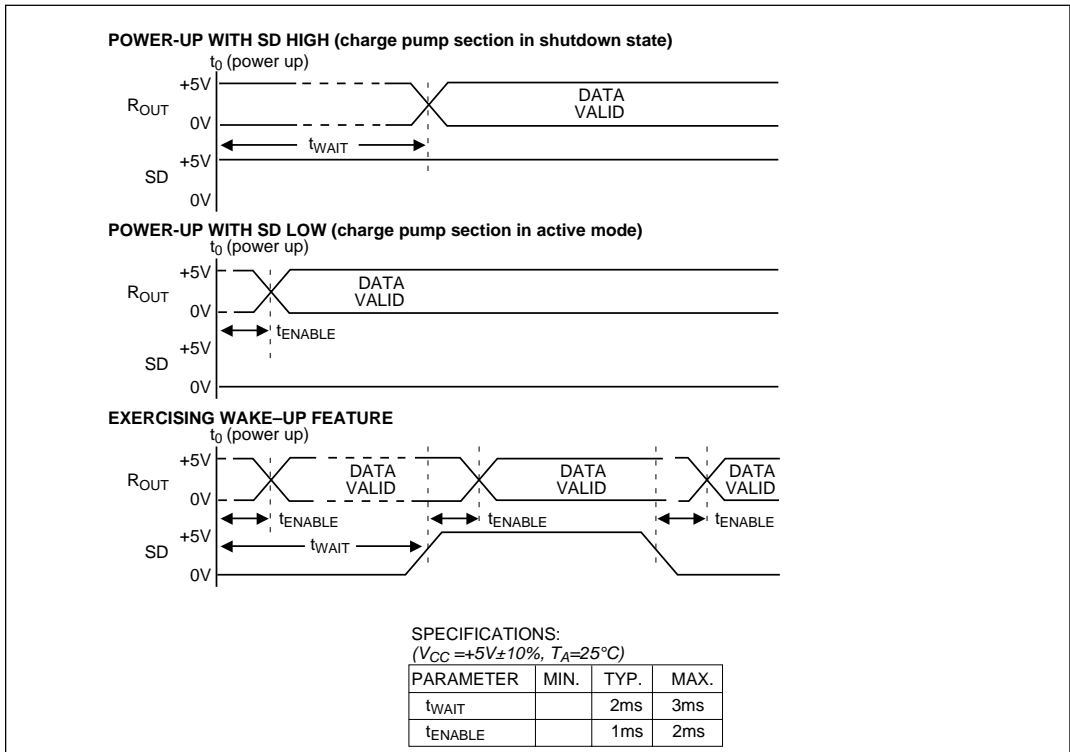

Figure 6. Wake-Up and Shutdown Timing

of the charge pump. If the **SP2XXB** is powered up with SD low, then only the 2ms delay time will apply (refer to *Figure 6*). Under normal operation, both the wait time and delay time should be transparent to the user.

With only the receivers activated, the device typically draws less than 5 μ A (10 μ A max) supply current. In the case of a modem interfaced to a computer in power-down mode, the **RI** (ring indicator) signal from the modem would be used to “wake up” the computer, allowing it to accept the data transmission.

After the ring indicator signal has propagated through the **SP2XXB** receiver, it can be used to trigger the power management circuitry of the computer to power up the microprocessor and bring the SD pin to the **SP2XXB** low, taking it out of shutdown. The receiver propagation delay is typically 1 μ s. The enable time for V+ and V- is typically 2ms. After V+ and V- have settled to their final values, a signal can be sent back to the modem on the **DTR** (Data Terminal Ready) pin signifying that the computer is ready to accept and transmit data.

All receivers that are active during shutdown maintain 500mV (typ.) of hysteresis.

Varying Capacitor Values

As stated earlier, the capacitor values are somewhat non-critical. Since they are an actual component of the charge pump circuitry, their value will affect its performance, which in turn affects the V_{OH} and V_{OL} levels. There is no upper limit for the value of any of the four capacitors; lower values will impact performance. C₁ and C₂ are responsible for the charge accumulation and can be reduced to 1 μ F; this will increase the output impedance of V+ and V-. Reducing these capacitor values will limit the ability of the **SP2XXA/B** to maintain the dc voltages needed to generate the RS-232 output levels. Capacitors C₃ and C₄ can also be reduced to 1 μ F; doing so will increase the ripple on V+ and V-.

Typically each driver will require 1 μ F of capacitance as a minimum to operate within all specified parameters; if five drivers are active in the circuit, then C₃ and C₄ should be 5 μ F. In order to operate

at these minimum values, the supply voltage must be maintained at +5.0V \pm 5%. Also, the ambient operating temperature must be less than 60°C.

The capacitor values must be chosen to suit the particular application. The designer must balance board space, cost and performance to maximize the design. The capacitors can be polarized or non-polarized, axial-leaded or surface-mount. As the size and value decrease, so does the cost; however, the value should be chosen to accommodate worst-case load conditions.

INTERFACE EXAMPLE – A MODEM ON THE IBM PC SERIAL PORT

The RS-232 standard defines 22 serial interface signals. These signals consist of ground lines, timing, data, control and test signals, plus a set of signals rarely used for a second data channel. Many of these signal lines are not used in typical RS-232 applications; in fact, the IBM® PC serial port is implemented using only nine pins.

For example, consider the case of a PC using this nine pin port to communicate with a peripheral device such as a modem. We see the following activity on each of the RS-232 lines as the computer and modem are activated and communicate with each other as well as the remote modem at the other end of the phone line.

Signal Ground (GND)

The Signal Ground pin acts as a reference for all the other signals. This pin is simply maintained at a 0V level to serve as a level to which all other signals are referenced. Both the PC and the modem will have this line connected to their respective internal ground lines.

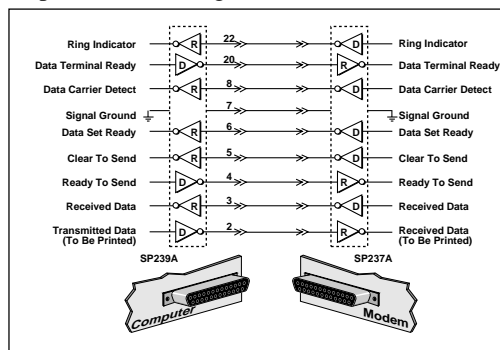

IBM Modem Port Interconnections

Data Terminal Ready (DTR)

This is the pin the computer uses to tell peripheral devices that it is on-line and ready to communicate.

Data Set Ready (DSR)

Peripheral devices use this line to tell the computer that they are on-line and ready to communicate. When the modem is turned on and has completed its self-test routine (assuming it does one), it will send a signal to the PC by asserting this line.

Request To Send (RTS)

The computer activates this line to notify the peripheral device that it is ready to send data. In this example, the computer notifies the modem that it is ready to send data to be transmitted by the modem.

Clear To Send (CTS)

This is the line on which the peripheral device tells the computer that it is ready to receive data from the computer. If the modem was not ready, i.e. it was performing a loop-back self-test, for example, it would not assert this line. Once the modem was ready to receive data from the PC, it would assert this line. When it receives the CTS signal from the modem, the PC knows that a data transmission path has been established between itself and the modem.

Transmitted Data (TD or TX)

This is the pin on which the computer sends the actual data signal to be transmitted, i.e. a positive voltage (+3V to +15V) to represent a logic "0", and a negative voltage (-3V to -15V) to represent a logic "1". The PC would send the data on this line to be transmitted by the modem.

Ring Indicator (RI)

This line is used by the peripheral device to tell the computer that a remote device wants to start communicating. The modem would activate the RI line to tell the computer that the remote modem was calling, i.e. the phone is ringing.

Data Carrier Detect (DCD)

This line is used by the modem to tell the computer that it has completed a transmission

path with the remote modem, and to expect to start receiving data at any time.

Received Data (RD or RX)

This is the pin on which the modem sends the computer the incoming data signal, i.e. a positive voltage (+3V to +15V) to represent a logic "0", and a negative voltage (-3V to -15V) to represent a logic "1".

INTERFACE EXAMPLE – A PRINTER ON THE IBM PC SERIAL PORT

The RS-232 standard defines 22 serial interface signals. These signals consist of ground lines, timing, data, control and test signals, plus a set of signals rarely used for a second data channel. Many of these signal lines are not used in typical RS-232 applications; in fact, the IBM® PC serial port is implemented using only nine pins.

For example, consider the case of a PC using this nine pin port to communicate with a peripheral device such as a printer. We see the following activity on each of the RS-232 lines as the computer and printer are activated and communicate.

Signal Ground (GND)

The Signal Ground pin acts as a reference for all the other signals. This pin is simply maintained at a 0V level to serve as a level to which all other signals are referenced. Both the PC and the printer will have this line connected to their respective internal ground lines.

Data Terminal Ready (DTR)

This is the pin the computer uses to tell peripheral devices that it is on-line and ready to communi-

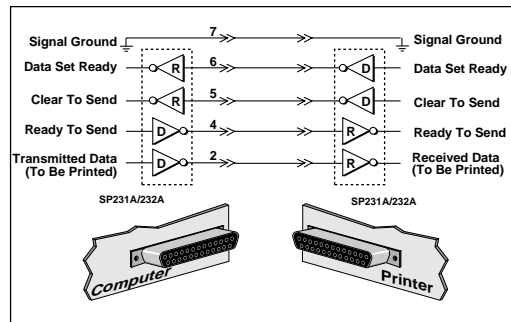

IBM Printer Port Interconnections

cate. Once the computer is powered-up and ready, it will send out a signal on the **DTR** to inform the printer that it is powered-up and ready to go. The printer really doesn't care, since it will simply print data as it is received. Accordingly, this pin is not needed at the printer.

Data Set Ready (DSR)

Peripheral devices use this line to tell the computer that they are on-line and ready to communicate. When the printer is turned on and has completed its self-test routine (assuming it does one), it will send a signal to the PC by asserting this line.

Request To Send (RTS)

The computer activates this line to notify the peripheral device that it is ready to send data. In this example, the computer notifies the printer that it is ready to send data to be printed by the printer.

Clear To Send (CTS)

This is the line on which the peripheral device tells the computer that it is ready to receive data from the computer. If the printer was not ready, i.e. it was out of paper, for example, it would not assert this line. Once the printer was ready to receive data from the PC, it would assert this line. When it receives the **CTS** signal from the printer, the PC knows that a data transmission path has been established between itself and the printer.

Transmitted Data (TD or TX)

This is the pin on which the computer sends the actual data signal representing the actual information to be printed, i.e. a positive voltage (+3V to +15V) to represent a logic "0", and a negative voltage (-3V to -15V) to represent a logic "1".

Ring Indicator (RI)

This line is used by the peripheral device to tell the computer that a remote device wants to start communicating. A modem would activate the **RI** line to tell the computer that a remote modem was calling, i.e. the phone is ringing. In the case of a printer, this line is unused.

Data Carrier Detect (DCD)

This line is used by a peripheral device to tell the computer to expect to start receiving data at any time. Since the printer would not be sending data to the PC in this case this line is not needed.

Received Data (RD or RX)

This is the pin on which the computer receives the incoming data signal, i.e. a positive voltage (+3V to +15V) to represent a logic "0", and a negative voltage (-3V to -15V) to represent a logic "1". Again, in this instance, since the printer will not be sending the PC any data, this line is not needed.

TYPICAL CIRCUITS

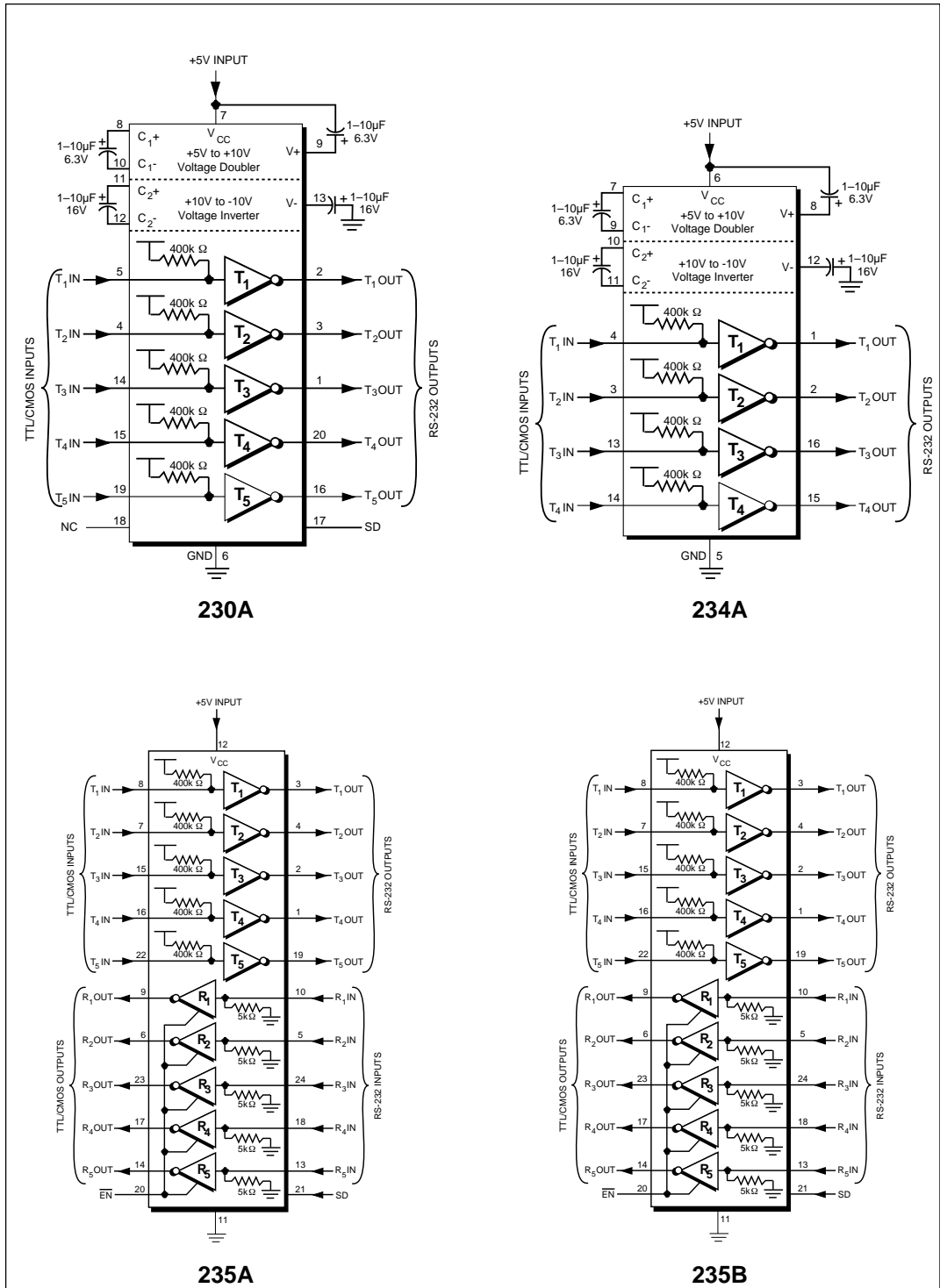

TYPICAL CIRCUITS

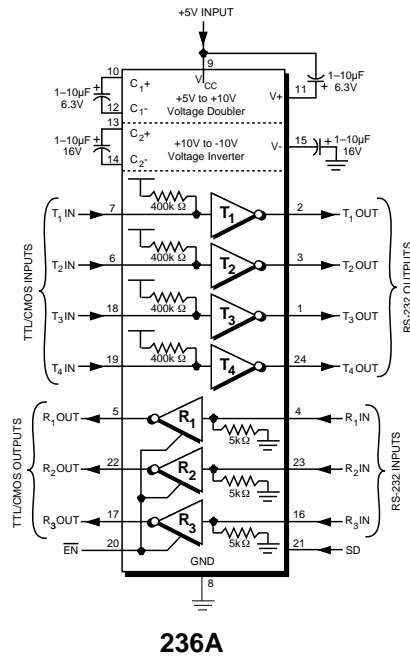

236A

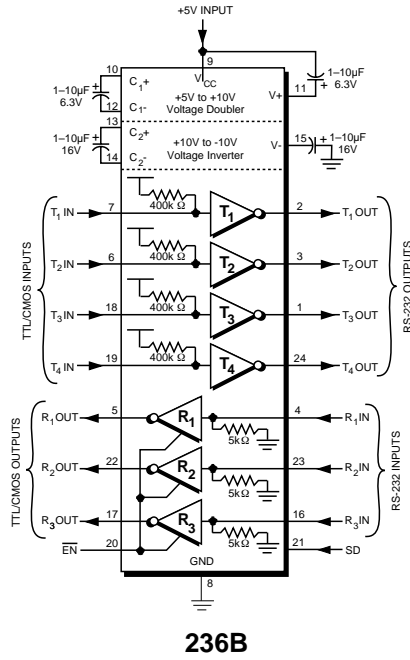

236B

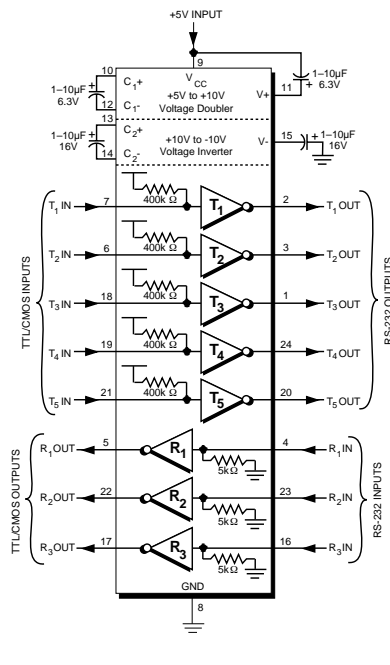

237A

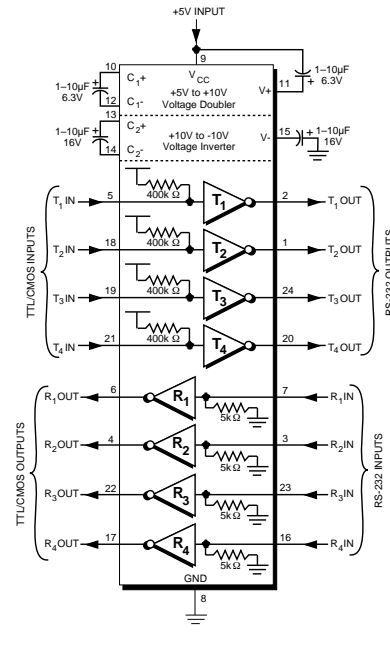

238A

TYPICAL CIRCUITS

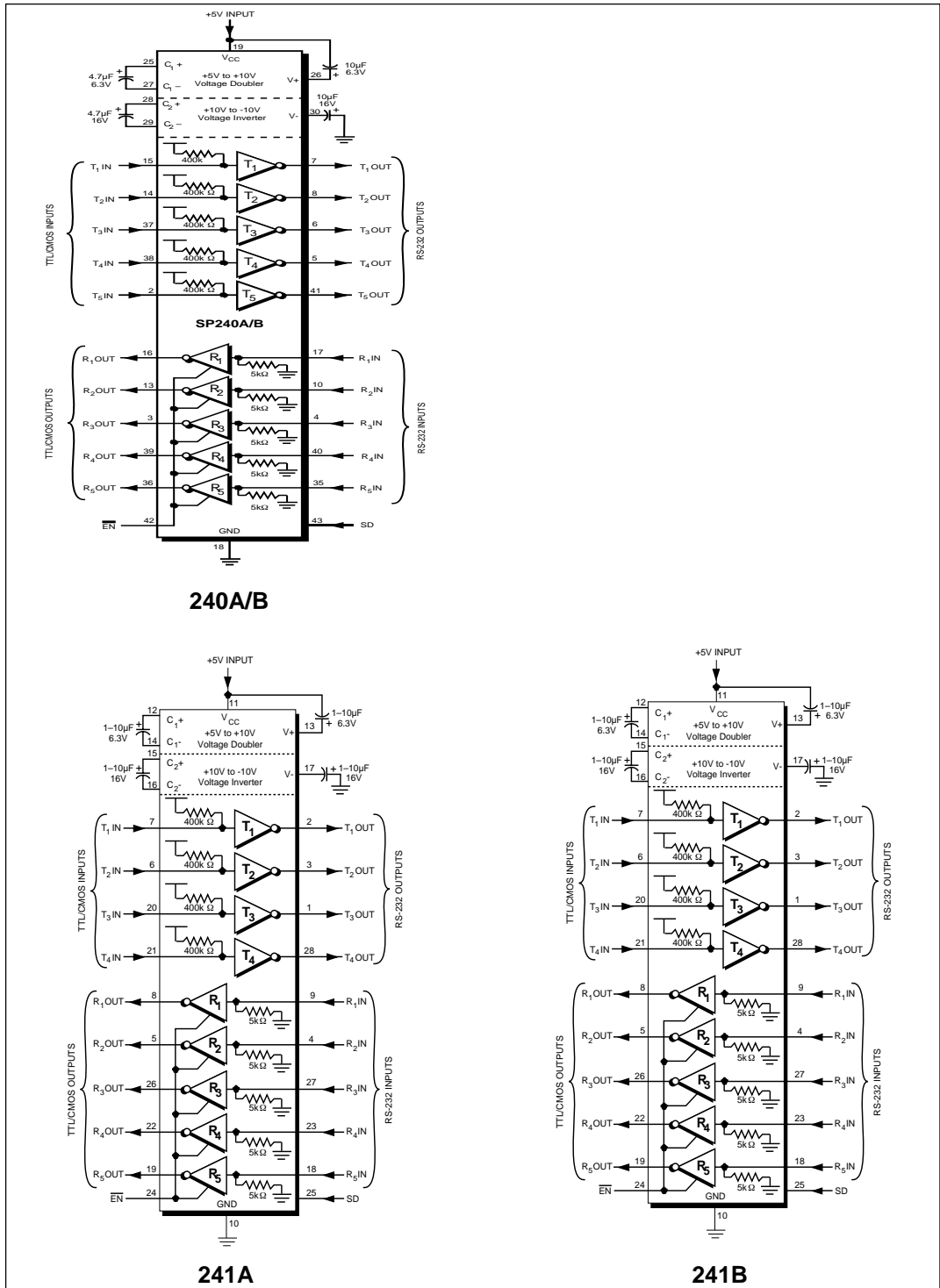

ORDERING INFORMATION

| Model | Temperature Range | Package |
|--------------------|-------------------------|--------------------|
| SP230ACP | 0°C to +70°C | 20 pin PDIP |
| SP230ACT | 0°C to +70°C | 20 pin WSOIC |
| SP230ACT/TR | 0°C to +70°C | 20 pin WSOIC |
| SP230ACX | 0°C to +70°C | Dice |
| SP230AEP | -40°C to +85°C | 20 pin PDIP |
| SP230AET | -40°C to +85°C | 20 pin WSOIC |
| SP230AET/TR | -40°C to +85°C | 20 pin WSOIC |
| SP234ACP | 0°C to +70°C | 16 pin PDIP |
| SP234ACT | 0°C to +70°C | 16 pin WSOIC |
| SP234ACT/TR | 0°C to +70°C | 16 pin WSOIC |
| SP234ACX | 0°C to +70°C | Dice |
| SP234AEP | -40°C to +85°C | 16 pin PDIP |
| SP234AET | -40°C to +85°C | 16 pin WSOIC |
| SP234AET/TR | -40°C to +85°C | 16 pin WSOIC |
| SP235ACP | 0°C to +70°C | 24 pin PDIP |
| SP235AEP | -40°C to +85°C | 24 pin PDIP |
| SP235BCP | 0°C to +70°C | 24 pin PDIP |
| SP235BEP | -40°C to +85°C | 24 pin PDIP |
| SP236ACS | 0°C to +70°C | 24 pin PDIP |
| SP236ACT | 0°C to +70°C | 24 pin WSOIC |
| SP236ACT/TR | 0°C to +70°C | 24 pin WSOIC |
| SP236ACX | 0°C to +70°C | Dice |
| SP236AES | -40°C to +85°C | 24 pin PDIP |
| SP236AET | -40°C to +85°C | 24 pin WSOIC |
| SP236AET/TR | -40°C to +85°C | 24 pin WSOIC |
| SP236BCS | 0°C to +70°C | 24 pin PDIP |
| SP236BCT | 0°C to +70°C | 24 pin WSOIC |
| SP236BCT /TR | 0°C to +70°C | 24 pin WSOIC |
| SP236BCX | 0°C to +70°C | Dice |
| SP236BES | -40°C to +85°C | 24 pin PDIP |
| SP236BET | -40°C to +85°C | 24 pin WSOIC |
| SP236BET /TR | -40°C to +85°C | 24 pin WSOIC |
| SP237ACS | 0°C to +70°C | 24 pin PDIP |
| SP237ACT | 0°C to +70°C | 24 pin WSOIC |
| SP237ACT/TR | 0°C to +70°C | 24 pin WSOIC |
| SP237ACX | 0°C to +70°C | Dice |
| SP237AES | -40°C to +85°C | 24 pin PDIP |
| SP237AET | -40°C to +85°C | 24 pin WSOIC |
| SP237AET/TR | -40°C to +85°C | 24 pin WSOIC |

Please consult factory for SP235B, SP236B, SP240B, SP241B, and dice.

Available in lead free packaging. To order add "-L" suffix to part number.

Example: SP230AEP = standard; SP230AEP-L = lead free

/TR = Tape and Reel

Pack quantity is 1,500 for WSOIC.



ANALOG EXCELLENCE

Sipex Corporation

**Headquarters and
Sales Office**
233 South Hillview Drive
Milpitas, CA 95035
TEL: (408) 934-7500
FAX: (408) 935-7600

ORDERING INFORMATION

| | | |
|-------------------|----------------------|----------------------|
| SP238ACS | 0°C to +70°C | 24 pin PDIP |
| SP238ACT | 0°C to +70°C | 24 pin WSOIC |
| SP238ACT/TR | 0°C to +70°C | 24 pin WSOIC |
| SP238ACX | 0°C to +70°C | Dice |
| SP238AES | -40°C to +85°C | 24 pin PDIP |
| SP238AET | -40°C to +85°C | 24 pin WSOIC |
| SP238AET/TR | -40°C to +85°C | 24 pin WSOIC |
| SP240ACF | 0°C to +70°C | 44 pin Quad Flatpack |
| SP240BCF | 0°C to +70°C | 44 pin Quad Flatpack |
| SP241ACT | 0°C to +70°C | 28 pin WSOIC |
| SP241ACT/TR | 0°C to +70°C | 28 pin WSOIC |
| SP241AET | -40°C to +85°C | 28 pin WSOIC |
| SP241AET/TR | -40°C to +85°C | 28 pin WSOIC |
| SP241BCT | 0°C to +70°C | 28 pin WSOIC |
| SP241BCT/TR | 0°C to +70°C | 28 pin WSOIC |
| SP241BET | -40°C to +85°C | 28 pin WSOIC |
| SP241BET/TR | -40°C to +85°C | 28 pin WSOIC |

Available in lead free packaging. To order add "-L" suffix to part number.

Example: SP230AET/TR = standard; SP230AET-L/TR = lead free

/TR = Tape and Reel

Pack quantity is 1,500 for WSOIC.



ANALOG EXCELLENCE

Sipex Corporation

**Headquarters and
Sales Office**
233 South Hillview Drive
Milpitas, CA 95035
TEL: (408) 934-7500
FAX: (408) 935-7600