

PART NUMBER	REVISION	DESCRIPTION	FEED TYPE
2151049-1	M	FINE CRIMP HEIGHT ADJUST	MECHANICAL
2151049-2	M	FINE CRIMP HEIGHT ADJUST	PNEUMATIC
5-2151049-1	M	SEAL STRIPPER CRIMPER TERMINATING UNIT	MECHANICAL
5-2151049-2	M	SEAL STRIPPER CRIMPER TERMINATING UNIT	PNEUMATIC
7-2151049-1	M	MECHANICAL AND CRIMP TOOLING KIT	MECHANICAL
7-2151049-2	M	PNEUMATIC AND CRIMP TOOLING KIT	PNEUMATIC
7-2151049-7	B	CRIMP TOOLING KIT	-

ATLANTIC VERSION TERMINATOR
 INTERFACE ADAPTER

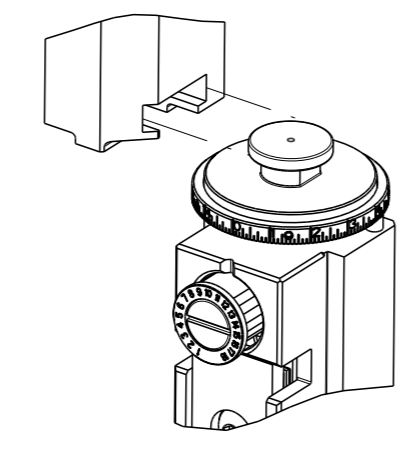

APPLICATOR DATA

CRIMP	SIZE	TYPE
WIRE	1.78 mm [.070]	F
INSUL	3.30 mm [.130]	O

APPLICATOR INSTRUCTIONS
 408-35042

TERMINAL DATA: TE TERMINATOR ELECTRONICS CRIMP SPECIFICATION

TERMINAL NAME: MCP 1.2 LOCKING LANCE RECET

WIRE STRIP LENGTH	TERMINAL INSULATION DIAMETER RANGE
3.30-3.90 mm [.130-.154 IN]	Ø1.90-2.40 mm [.075-.094 IN]

TERMINAL APPLICATION SPECIFICATION 114-18464 Rev M

TERMINALS APPLIED

TE TERMINAL	TE TERMINAL	TE SEAL	TE SEAL	SEAL INSULATION DIAMETER RANGE
1452671-1	7-1452671-1		967067-1	Ø1.4 - 2.1 mm
1452671-2	7-1452671-2		963142-1	Ø1.4 - 2.4 mm
1452671-3	7-1452671-3			

WIRE SIZE	CRIMP HEIGHT mm [INCH]	CRIMP HEIGHT REFERENCE SETTING
1.50mm2	1.31+/-0.05 [0.052+/-0.002]	5.0
16 AWG	1.26+/-0.05 [0.050+/-0.002]	5.6
1.00mm2	1.10+/-0.05 [0.043+/-0.002]	7.2
18 AWG	1.05+/-0.05 [0.041+/-0.002]	7.7

- 1 RECOMMENDED SPARE PARTS
 - 2 REFER TO SUPPLIED INSTRUCTION SHEET FOR CLEANING, LUBRICATION AND STORAGE OF APPLICATOR.
 - 3 APPLY PART NUMBER 1-23419-5 LOCTITE TO THREADS OF ITEM 180. APPLY PART NUMBER 2-23419-6 LOCTITE TO THREADS OF ITEM 242.
 - 4 CRIMP HEIGHT REFERENCE SETTING WAS THE SETTING USED WHEN THE APPLICATOR WAS QUALIFIED AT THE FACTORY. ADJUSTMENT MAY BE NECESSARY WHEN RUNNING APPLICATOR IN THE FIELD.
 - 5 APPLY TORO-SEAL IN ALLEN SOCKET TO FILL HOLE AFTER FLAT HD HAS BEEN ADJUSTED TO CORRECT HEIGHT AT QUALIFICATION. APPLY #1-23419-5 LOC-TITE TO THREADS.
 - 6 TERMINAL LUBRICANT IS RECOMMENDED.
7. UNLESS SPECIFIED OTHERWISE TORQUE VALUES SHALL BE USED PER DOCUMENT, 101-35000.

***WARNING**
 ON INSTALLATION, SET WIRE DISC TO CRIMP HEIGHT REFERENCE SETTING FOR LARGEST WIRE SIZE. CRIMP HEIGHT REFERENCE SETTINGS GREATER THAN THE VALUE SHOWN MAY CAUSE DAMAGE TO THE CRIMP TOOLING, REFER TO THE INSTRUCTION SHEET FOR PROPER SETUP AND ADJUSTMENTS.

LOC	DIST	REV	DATE	OWN	APVD
A	66	K	04MAY2021	JWC	GB
		L	23MAR2022	TB	TE
		L1	02AUG2022	FJ	YY
		M	24AUG2022	FZ	JAH

REV	DATE	OWN	APVD	DESCRIPTION	ITEM NO	
-	-	-	-	1803515-3	RAM ASSEMBLY, SF ATLANTIC	293
-	-	-	-	2-1803583-1	APPLICATOR BASIC ASSEMBLY, SF	292
-	1	-	1	2119641-1	FEED CAM, AIR FEED	248
-	1	1	1	2119082-4	CAM, SNAIL, INSULATION ADJUSTMENT	244
-	1	1	1	2079764-1	WASHER, WAVE SPRING, CREST-TO-CREST	243
3	-	1	1	2119083-1	RETAINER, INSULATION DIAL	242
-	1	1	1	7-18023-7	SCR, SKT HD CAP M3 X 4.0	241
-	-	1	-	2119580-1	MECHANICAL FEED ASSEMBLY	239
-	1	-	1	2844940-1	AIR FEED MODULE	238
-	-	-	1	4-1722335-3	STRIPPER, SIDE FEED	182
-	-	-	1	1-5018030-0	NUT, HEX, REG, RoHS, M3.5	181
3	-	-	1	1752354-7	STANDOFF, HOLD-DOWN	180
-	-	-	1	9931111-1	PIN, SLOTTED SPRING 3.0 X 20.0	177
-	-	-	1	5-22280-0	SPRING, COMPRESSION	176
-	-	-	1	1752353-3	GUIDE PIN, HOLDDOWN	175
-	-	-	1	1901680-2	GUIDE PIN, HOLDDOWN	174
-	REF	REF	REF	994970-2	COUNTER, MAGNETIC	164
6	-	1	1	2119955-1	ASSY, LUBRICATOR, SIDE FEED	113
-	1	1	1	2844908-1	SCREW, LOCKING	99
-	1	1	1	2844907-1	POST, LOCKING	98
-	1	1	1	455888-4	SPACER, CRIMPER	82
-	1	1	1	1803607-3	DOCUMENTATION PACKAGE	71
-	1	1	1	2119740-1	TAG, IDENTIFICATION	67
-	2	2	2	2168078-1	SCREW, DRIVE, RH, RoHS, 2 x .188	66
-	1	1	1	2168083-2	SCR, SKT HD CAP, RoHS, M4 X 8.0	60
-	1	1	1	5-18022-5	SCR, HEX HD CAP, M4 X 6.0	59
5	-	1	1	985575-3	SCR, FLT SKT HD CAP M3 X 10.0	57
-	1	1	1	1338685-1	PAWL, FEED	56
-	4	4	4	2168083-3	SCR, SKT HD CAP, RoHS, M4 X 12.0	54
-	2	2	2	2-2168083-5	SCR, SKT HD CAP, RoHS, M4 X 14	53
-	1	1	1	5018030-1	NUT, HEX, REG, RoHS, M3	52
-	1	1	1	811242-5	BUMPER, HOLD DOWN	51
-	1	1	1	690753-2	SPACER, TONKER	50
-	1	2	1	18023-9	SCR, SKT HD CAP M4 X 6.0	49
-	-	1	-	2119652-1	FEED CAM, PRE FEED	48
-	-	1	-	2119653-1	FEED CAM, POST FEED	47
-	1	1	-	1803583-9	APPLICATOR BASIC ASSEMBLY, SF	46
-	1	1	-	1803515-1	RAM ASSEMBLY, SF ATLANTIC	44
-	1	1	1	1803602-1	SCR, BHSC, RoHS (M8 X 25)	41
-	1	1	1	1752356-6	SUPPORT, TERMINAL	34
-	2	2	2	2079383-5	SCR, BHSC, RoHS (M4 X 20)	33
-	2	2	2	2-2844962-8	SPACER, CYLINDRICAL, STRIP GUIDE	30
-	1	1	1	2844992-2	ASSEMBLY, STRIP GUIDE	29
-	1	1	1	455888-5	SPACER, CRIMPER	28
-	1	1	1	1320928-2	STRIP GUIDE	24
-	1	1	-	2168083-2	SCR, SKT HD CAP, RoHS, M4 X 8.0	21
-	2	2	1	1-18028-2	WASHER, FLAT, REG M4	20
-	1	1	-	2119533-1	STRIPPER, SIDE FEED	19
1	-	1	1	2119806-1	INSERT, SHEAR	13
-	1	1	1	3-22280-3	SPRING, COMPRESSION	12
-	1	1	1	1-356885-4	STOP, SHEAR	11
1	-	1	1	2119805-1	SHEAR HOLDER, FRONT	10
1	-	1	1	318707-1	FLOATING SHEAR, FRONT	9
1	2	2	1	4-1333203-8	ANVIL, COMBINATION	8
-	1	1	1	2-240641-4	SPACER	7
-	1	1	1	2119781-1	DEPRESSOR, SHEAR	5
-	1	1	1	3-238011-8	BLOCK, CRIMPER SPACER	4
1	2	2	1	3-2119784-7	CRIMPER, INSULATION O PREMIUM	3
1	2	2	1	1633169-3	CRIMPER, WIRE, SPECIAL	1

ATLANTIC VERSION
 Shown on sheets 1 of 4 & 2 of 4
 (Pacific version shown on sheets 3 of 4 & 4 of 4)

DIMENSIONS:	TOLERANCES UNLESS OTHERWISE SPECIFIED:	OWN	DATE	NAME	DESCRIPTION	ITEM NO
mm	0 PLC ± 1 PLC ± 2 PLC ± 3 PLC ± 4 PLC ± ANGLES ±	C. CHEN	30APR2011	S. XI	TE Connectivity Harrisburg, PA 17105-3608	
		APVD	30APR2011	J. CRUZ	Ocean Side Feed Applicator	
MATERIAL	FINISH	WEIGHT	SCALE	SHEET	REV	
			1:2	1 of 4	M	

PART NUMBER	REVISION	DESCRIPTION	FEED TYPE
2-2151049-1	M	FINE CRIMP HEIGHT ADJUST	MECHANICAL
2-2151049-2	M	FINE CRIMP HEIGHT ADJUST	PNEUMATIC
7-2151049-7	B	CRIMP TOOLING KIT	-

PACIFIC VERSION TERMINATOR
INTERFACE ADAPTER

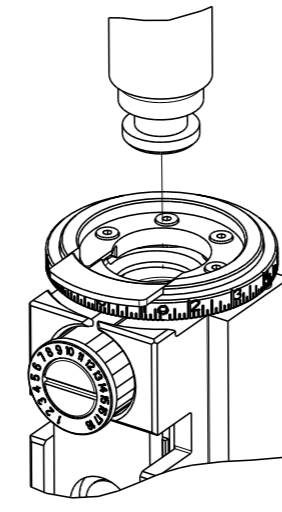

APPLICATOR DATA		
CRIMP	SIZE	TYPE
WIRE	1.78 mm [.070]	F
INSUL	3.30 mm [.130]	O

APPLICATOR INSTRUCTIONS
408-35042

TERMINAL DATA: TE TERMINAL TO ELECTRONICS CRIMP SPECIFICATION	
TERMINAL NAME: MCP 1.2 LOCKING LANCE RECET	
WIRE STRIP LENGTH 3.30-3.90 mm [.130-.154 IN]	TERMINAL INSULATION DIAMETER RANGE Ø1.90-2.40 mm [.075-.094 IN]
TERMINAL APPLICATION SPECIFICATION 114-18464 Rev M	

TERMINALS APPLIED				SEAL INSULATION DIAMETER RANGE
TE TERMINAL	TE TERMINAL	TE SEAL	TE SEAL	
1452671-1	7-1452671-1		967067-1	Ø1.4 - 2.1 mm
1452671-2	7-1452671-2		963142-1	Ø1.4 - 2.4 mm
1452671-3	7-1452671-3			

WIRE SIZE	CRIMP HEIGHT mm [INCH]	CRIMP HEIGHT REFERENCE SETTING
1.50mm2	1.31+/-0.05 [.052+/-0.002]	5.0
16 AWG	1.26+/-0.05 [.050+/-0.002]	5.6
1.00mm2	1.10+/-0.05 [.043+/-0.002]	7.2
18 AWG	1.05+/-0.05 [.041+/-0.002]	7.7



- 1 RECOMMENDED SPARE PARTS
- 2 REFER TO SUPPLIED INSTRUCTION SHEET FOR CLEANING, LUBRICATION AND STORAGE OF APPLICATOR.
- 3 APPLY PART NUMBER 2-23419-6 LOCTITE TO THREADS OF ITEM 242.
- 4 CRIMP HEIGHT REFERENCE SETTING WAS THE SETTING USED WHEN THE APPLICATOR WAS QUALIFIED AT THE FACTORY. ADJUSTMENT MAY BE NECESSARY WHEN RUNNING APPLICATOR IN THE FIELD.
- 5 APPLY TORO-SEAL IN ALLEN SOCKET TO FILL HOLE AFTER FLAT HD HAS BEEN ADJUSTED TO CORRECT HEIGHT AT QUALIFICATION. APPLY #1-23419-5 LOC-TITE TO THREADS.
- 6 TERMINAL LUBRICANT IS RECOMMENDED.
- 7. UNLESS SPECIFIED OTHERWISE TORQUE VALUES SHALL BE USED PER DOCUMENT, 101-35000.

***WARNING**
ON INSTALLATION, SET WIRE DISC TO CRIMP HEIGHT REFERENCE SETTING FOR LARGEST WIRE SIZE. CRIMP HEIGHT REFERENCE SETTINGS GREATER THAN THE VALUE SHOWN MAY CAUSE DAMAGE TO THE CRIMP TOOLING, REFER TO THE INSTRUCTION SHEET FOR PROPER SETUP AND ADJUSTMENTS.

ENTRY LEVEL APPLICATOR		ITEM SUBSTITUTION LIST		
PART NUMBER	SAME AS	ITEM	ITEM DESCRIPTION	SUBSTITUTE PART NUMBER
8-2151049-1	2151049-1	1	WIRE CRIMPER	1803661-3
8-2151049-2	2151049-2	3	INSULATION CRIMPER	3-1803604-7
9-2151049-1	2-2151049-1	46	BASIC SUB -ASSEMBLY	1803940-9
9-2151049-2	2-2151049-2	141	BASIC SUB -ASSEMBLY	1-1803940-0
			LUBRICATOR	DELETE

LOC	DIST	REVISIONS			
A	66	REV	DATE	BY	APPD
-	-	SEE SHEET 1	-	-	-

-	1	1	2119082-4	CAM, SNAIL, INSULATION ADJUSTMENT	244
-	1	1	2079764-1	WASHER, WAVE SPRING, CREST-TO-CREST	243
-	1	1	2119083-1	RETAINER, INSULATION DIAL	242
-	1	1	7-18023-7	SCR, SKT HD CAP M3 X 4.0	241
-	-	1	2119580-1	MECHANICAL FEED ASSEMBLY	239
-	1	-	2844940-1	AIR FEED MODULE	238
-	REF	REF	994970-2	COUNTER, MAGNETIC	164
-	1	-	2119641-2	FEED CAM, AIR FEED	151
-	1	1	2168083-8	SCR, SKT HD CAP, RoHS, M4 X 16	144
-	4	4	2168083-9	SCR, SKT HD CAP, RoHS, M4 X 20	143
-	-	1	2119653-2	FEED CAM, POST FEED	142
-	1	1	1-1803583-0	APPLICATOR BASIC ASSEMBLY, SF	141
-	1	1	1803516-1	RAM ASSEMBLY, SF PACIFIC	140
-	1	1	2119955-1	ASSY, LUBRICATOR, SIDE FEED	113
-	1	1	2844908-1	SCREW, LOCKING	99
-	1	1	2844907-1	POST, LOCKING	98
-	1	1	455888-4	SPACER, CRIMPER	82
-	1	1	1803607-3	DOCUMENTATION PACKAGE	71
-	1	1	2119740-1	TAG, IDENTIFICATION	67
-	2	2	2168078-1	SCREW, DRIVE, RH, RoHS, 2 x .188	66
-	1	1	5-18022-5	SCR, HEX HD CAP, M4 X 6.0	59
-	1	1	985575-3	SCR, FLT SKT HD CAP M3 X 10.0	57
-	1	1	1338685-1	PAWL, FEED	56
-	2	2	2-2168083-5	SCR, SKT HD CAP, RoHS, M4 X 14	53
-	1	1	5018030-1	NUT, HEX, REG, RoHS, M3	52
-	1	1	811242-5	BUMPER, HOLD DOWN	51
-	1	1	690753-2	SPACER, TONKER	50
-	1	2	18023-9	SCR, SKT HD CAP M4 X 6.0	49
-	-	1	2119652-1	FEED CAM, PRE FEED	48
-	1	1	1803602-1	SCR, BHSC, RoHS (M8 X 25)	41
-	1	1	1752356-6	SUPPORT, TERMINAL	34
-	2	2	2079383-5	SCR, BHSC, RoHS (M4 X 20)	33
-	2	2	2-2844962-8	SPACER, CYLINDRICAL, STRIP GUIDE	30
-	1	1	2844992-2	ASSEMBLY, STRIP GUIDE	29
-	1	1	455888-5	SPACER, CRIMPER	28
-	1	1	1320928-2	STRIP GUIDE	24
-	1	1	2168083-2	SCR, SKT HD CAP, RoHS, M4 X 8.0	21
-	2	2	1-18028-2	WASHER, FLAT, REG M4	20
-	1	1	2119533-1	STRIPPER, SIDE FEED	19
-	1	1	2119806-1	INSERT, SHEAR	13
-	1	1	3-22280-3	SPRING, COMPRESSION	12
-	1	1	1-356885-4	STOP, SHEAR	11
-	1	1	2119805-1	SHEAR HOLDER, FRONT	10
-	1	1	318707-1	FLOATING SHEAR, FRONT	9
-	1	1	4-1333203-8	ANVIL, COMBINATION	8
-	1	1	2-240641-4	SPACER	7
-	1	1	2119781-1	DEPRESSOR, SHEAR	5
-	1	1	3-238011-8	BLOCK, CRIMPER SPACER	4
-	1	1	3-2119784-7	CRIMPER, INSULATION O PREMIUM	3
-	1	1	1633169-3	CRIMPER, WIRE, SPECIAL	1

PACIFIC VERSION
Shown on sheets 3 of 4 & 4 of 4
(Atlantic version shown on sheets 1 of 4 & 2 of 4)

DIMENSIONS:		TOLERANCES UNLESS OTHERWISE SPECIFIED:		APPROVED:		NAME:	
mm	0 PLC ±	1 PLC ±	2 PLC ±	3 PLC ±	4 PLC ±	ANGLES FINISH	
MATERIAL		WEIGHT		SCALE	1:2	SHEET	3 of 4

OWN: C. CHEN 30APR2011
CHK: S. XI 30APR2011
APVD: J. CRUZ 30APR2011

NAME: Ocean Side Feed Applicator

SIZE: A1 CAGE CODE: 00779 DRAWING NO: 2151049

CUSTOMER ACCESSIBLE PRODUCTION DRAWING

