

REVISIONS			
REV	DESCRIPTION, ECN, EAR NO.	DATE	APP'D
A	PRODUCT DRAWING (EAR 13901)	AUG16/11	K.L.

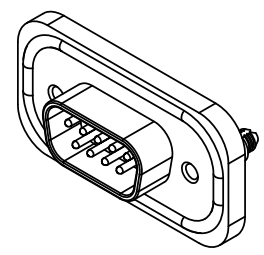

RECOMMENDED PANEL CUTOUT

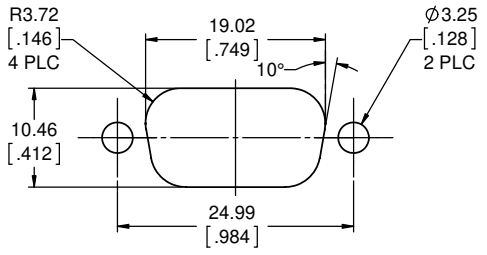
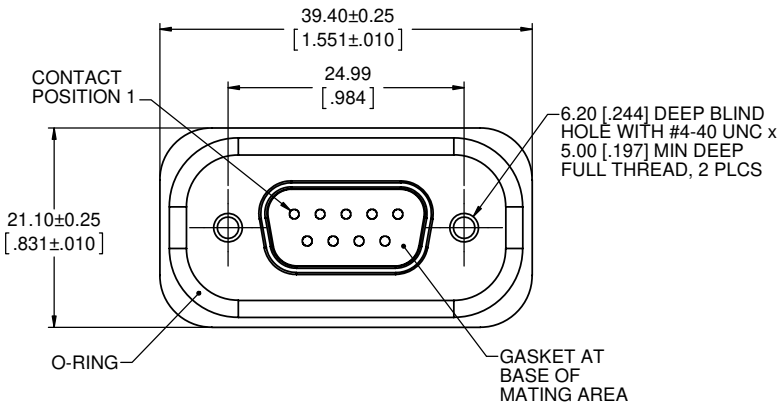
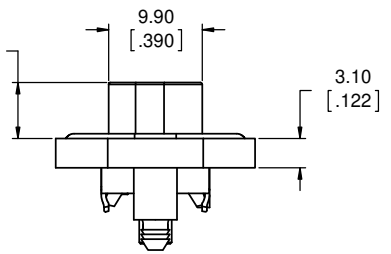
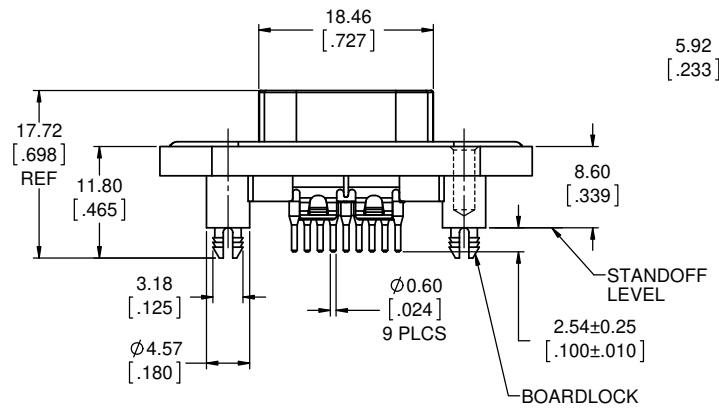

ORDERING CODE: M D B R - E 0 9 P E - 8 6 0

SERIES, RUGGED D-SUB
 SIZE E SHELL, 9 CONTACTS
 CONNECTOR TYPE (P = PIN)
 TERMINATION TYPE (E = PCB TAIL)
 VARIATION CODE
 860 = #4-40 THREADED STANDOFF WITH BOARDLOCK
 WIDE FLANGE DIECAST SHELL WITH O-RING FACE SEAL

NOTES:

- ALL MATERIALS ARE RoHS COMPLIANT PER EU DIRECTIVE 2002/95/EC AND AMENDMENTS
 SHELL: DIECAST ZINC ALLOY, NICKEL PLATED
 CONTACTS: COPPER ALLOY WITH 0.76µm [30µ"] MIN GOLD OVER 1.27µm [50µ"] MIN NICKEL PLATING
 INSULATOR: HIGH TEMPERATURE RESISTANT THERMOPLASTIC, FLAMMABILITY RATING UL94V-0, BLACK
 GASKET: SILICONE RUBBER, BLACK
 O-RING: SILICONE RUBBER, RED
- ENVIRONMENTAL PERFORMANCE PER IEC 60529 CODE IP67 FOR SEAL BETWEEN MATING AREA AND PCB SIDE OF CONNECTOR. O-RING PROVIDES SEAL TO INSIDE FACE OF THE PANEL.
- ELECTRICAL CHARACTERISTICS:
 CURRENT RATING: 5 AMPS
 DWV: 1500V DC AT SEA LEVEL
- OPERATING TEMPERATURE: -40°C TO +105°C
- CONNECTOR SEAL TO WITHSTAND TEMPERATURE EXPOSURE OF 150°C FOR 180 SECONDS (SOLDER PREHEAT) FOLLOWED BY 265°C FOR 8 SECONDS (SOLDER BATH). AFTER TEMPERATURE EXPOSURE, CONNECTOR SEAL TO WITHSTAND 34 kPa (5 PSI) PRESSURE.
- RECOMMENDED TORQUE FOR SCREW TIGHTENING (WITH MORE THAN 2.3mm (.090") THREAD ENGAGEMENT):
 STEEL SCREWS - 0.45 TO 0.65 N-m (4 TO 5.75 IN-LBS)
 BRASS SCREWS - 0.35 TO 0.50 N-m (3.1 TO 4.5 IN-LBS)
- CONSULT WITH AMPHENOL CANADA REGARDING HEX JACK SOCKETS, DUST COVERS OR OTHER ACCESSORIES.

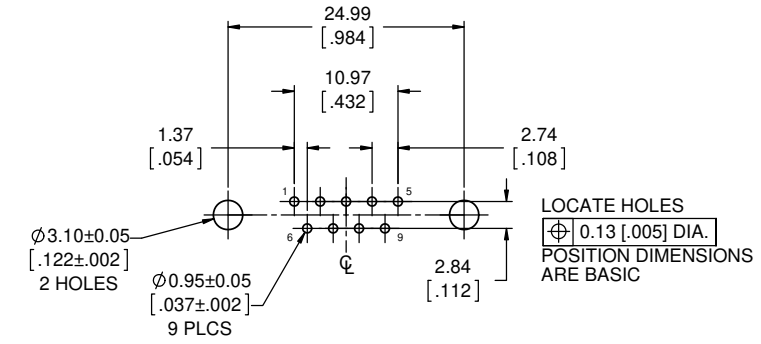

RECOMMENDED P.C.B LAYOUT
(COMPONENT SIDE OF BOARD)



UNLESS SPECIFIED OTHERWISE	DRAWN	M.SHAH	AUG12/11
PRIMARY UNITS MILLIMETERS	CHECKED		
SECONDARY INCHES	M.E. APP'D		
REFERENCE IN PARENTHESES	Q.A. APP'D		
GENERAL TOLERANCES	DWG APPR.	K.LAMBIE	AUG16/11
1 DECIMAL PLACE	ENG. REL. NO.	EAR 13901	
2 DECIMAL PLACES ±0.15	REF.		
3 DECIMAL PLACES	THIRD ANGLE PROJECTION		
ANGULAR DEGREES	DO NOT SCALE DRAWING		

Amphenol Canada Corp.
www.amphenolcanada.com

MDBR SERIES RUGGED D-SUB CONNECTOR, 9 POSITION PIN, VERTICAL PCB TAILS, RoHS COMPLIANT

DWG. NO. **P-MDBR-E09PE-860** REV **A**

CODE ID NO. 03554 DWG SIZE: X SCALE: 5:2 SHEET 1 OF 1