

SPECIFICATION

Part No. : **FXP290.07.0100A**

Model : 915MHz ISM Band Flex Circuit Antenna

Features : 75*45*0.1mm
100mm Ø1.13 Cable
RoHS & REACH compliant



1. OVERVIEW

The Taoglas FXP290 915 MHz ISM Antenna covers from 902-928 MHz used in the 915 MHz ISM (Industrial Scientific Medical) Band. The antenna has been designed in a flexible material with a square form-factor and cable connection for an easy installation. The antenna works on different plastic materials and thickness. We have selected a piece of ABS with 2 mm of thickness as a baseline for testing.

2. ANTENNA CHARACTERISTICS

Parameter	Specification
Frequency Range	902MHz to 928MHz
Return Loss (dB)	-20
Efficiency (%)	40
Gain (dBi)	1.5
Impedance	50 Ω
VSWR	$\leq 2:1$
Polarization	Linear
Power Handled	5W
Operation Temperature	-40°C ~ +85°C
Storage Temperature	-40°C ~ +85°C
Dimensions	75*45*0.1mm
Weight	1.5g
Connector	MHFII (U.FL Compatible)
Cable Standard	Mini-Coax 1.13 mm
Cable Length and color	100mm, Black
RoHS Compliant	Yes
Adhesive	3M 467

3. TEST SET UP

An ETS-Lindgren 3D Scan System with Anechoic Chamber

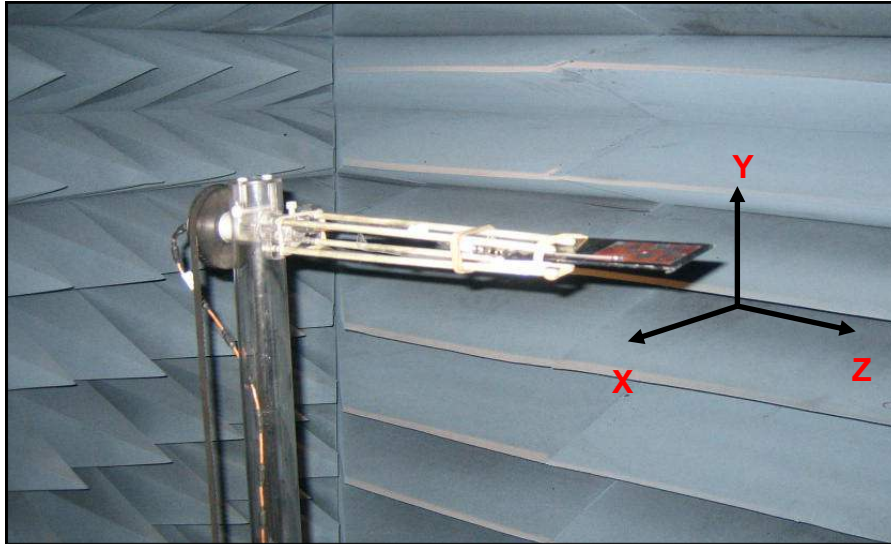

Figure 1. ETS-Lindgren System.

Rhode & Schwartz ZVL6 Vector Network Analyzer

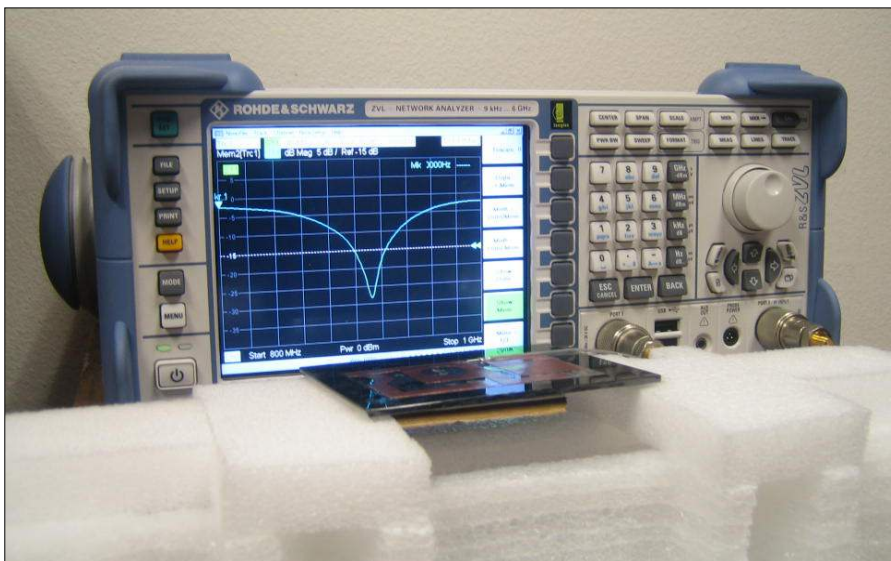

Figure 2. Network Analyzer.

4. ANTENNA PARAMETERS

The next antenna parameter graphs like Return Loss, VSWR and smith chart were measured in the Agilent Rhode & Schwartz ZVL6 Vector Network Analyzer. The Gain, Efficiency and Radiation Patterns were measured in the ETS-Lindgren 3D Scan System.

4.1. Return Loss Data

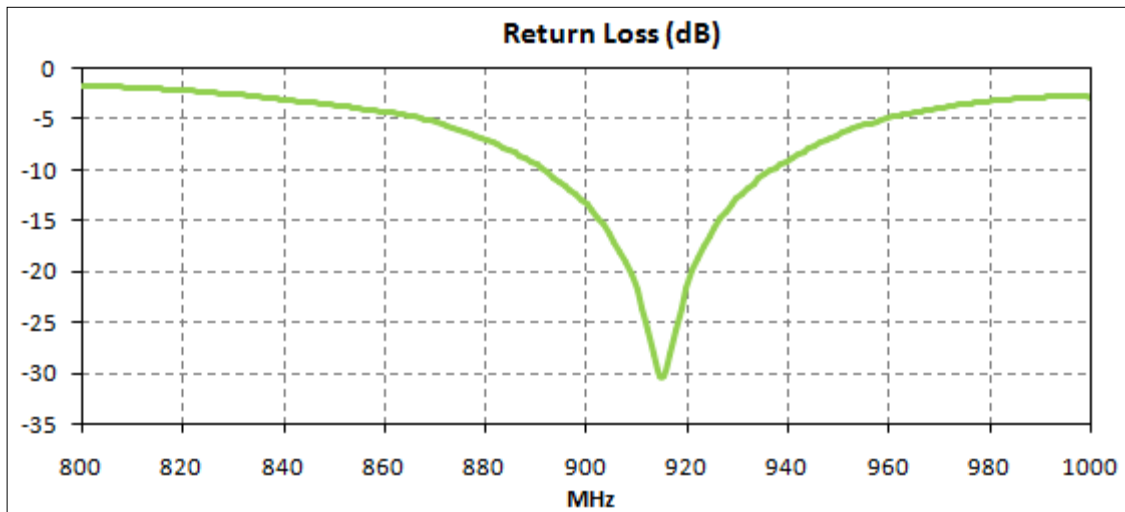

Figure 3. Return Loss for the FXP290 Antenna.

4.2. VSWR Data

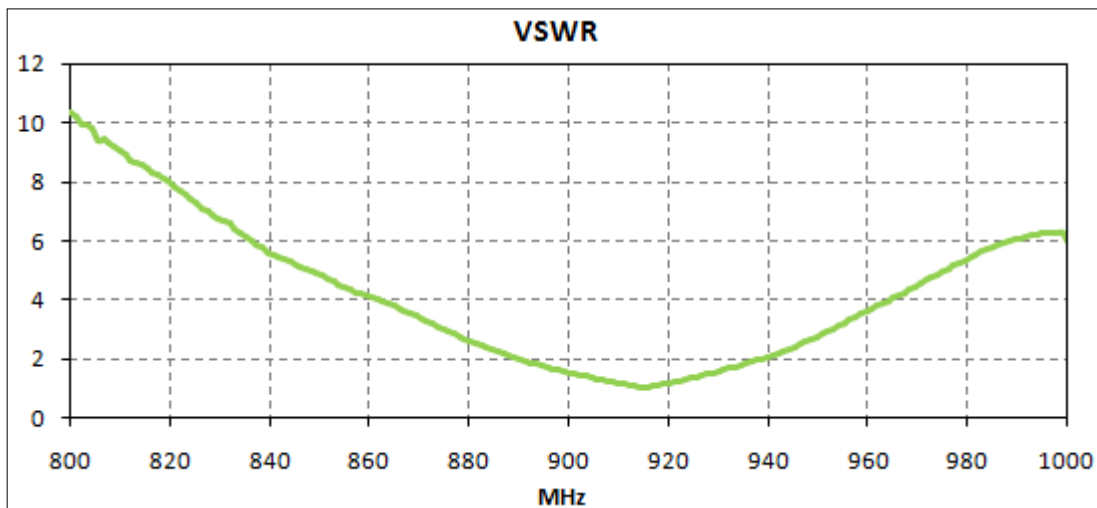

Figure 4. VSWR for the FXP290 Antenna.

4.3. Smith Chart Data

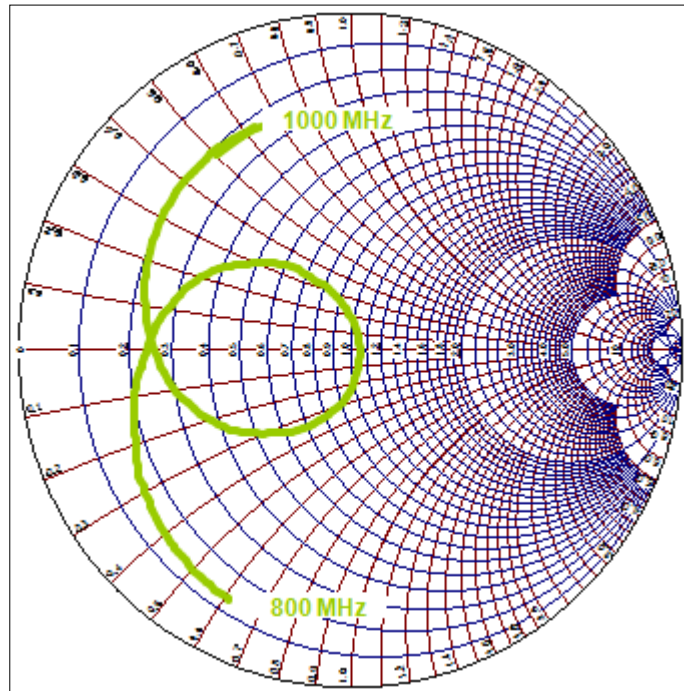

Figure 5. Smith Chart for the FXP290 Antenna.

4.4. Efficiency Data



Figure 6. Efficiency for the FXP290 Antenna.

4.5. Gain Data

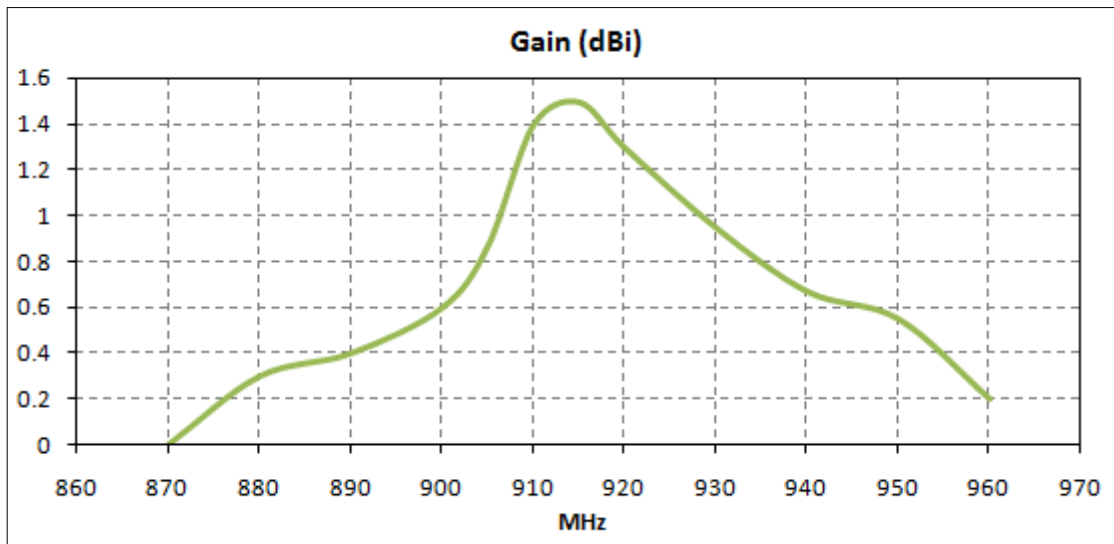

Figure 7. Gain for the FXP290 Antenna.

4.6. Radiation Pattern Data.

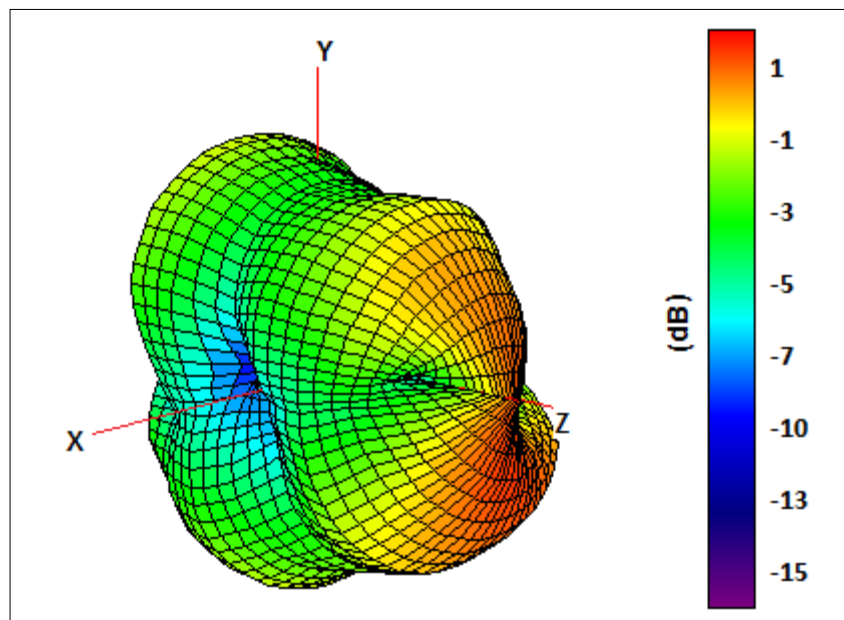

Figure 8. Radiation pattern 3D View, Figure 1 as reference (dB).

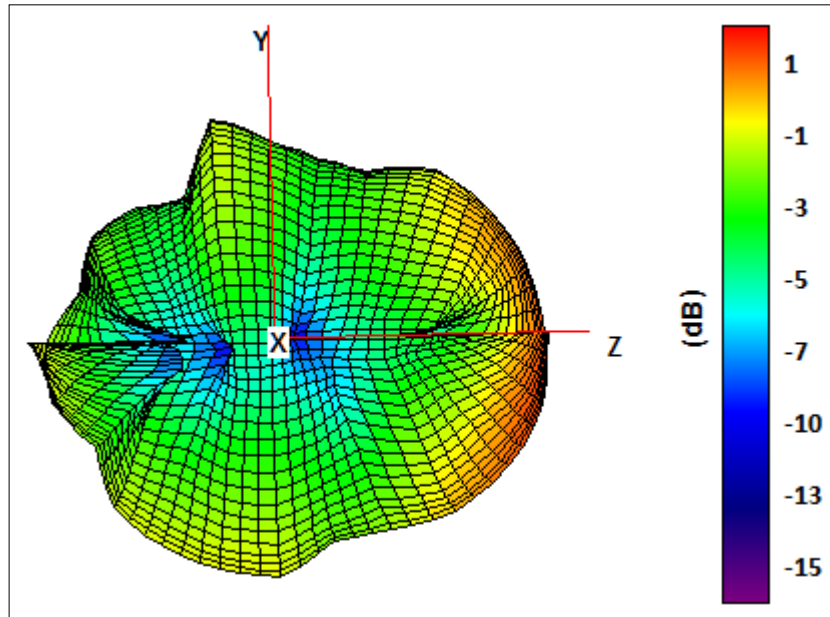

Figure 9. Radiation pattern YZ Plane, Figure 1 as reference (dB).

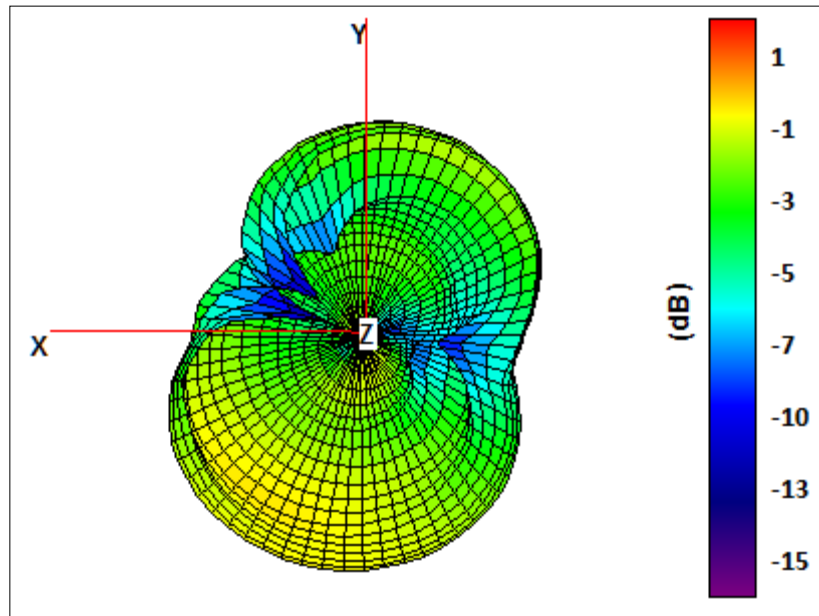

Figure 10. Radiation pattern XY plane, Figure 1 as reference (dB).

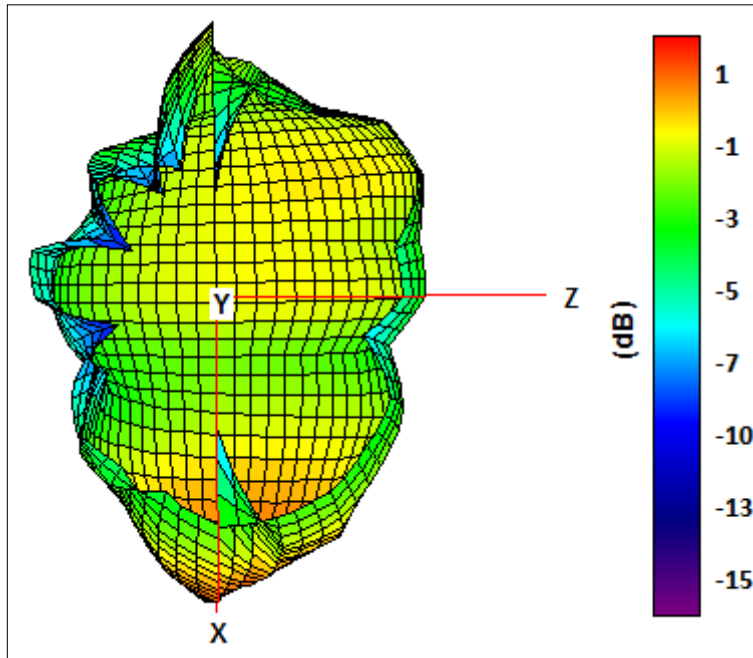

Figure 11. Radiation pattern XY plane, Figure 1 as reference (dB).

5. MECHANICAL DRAWING

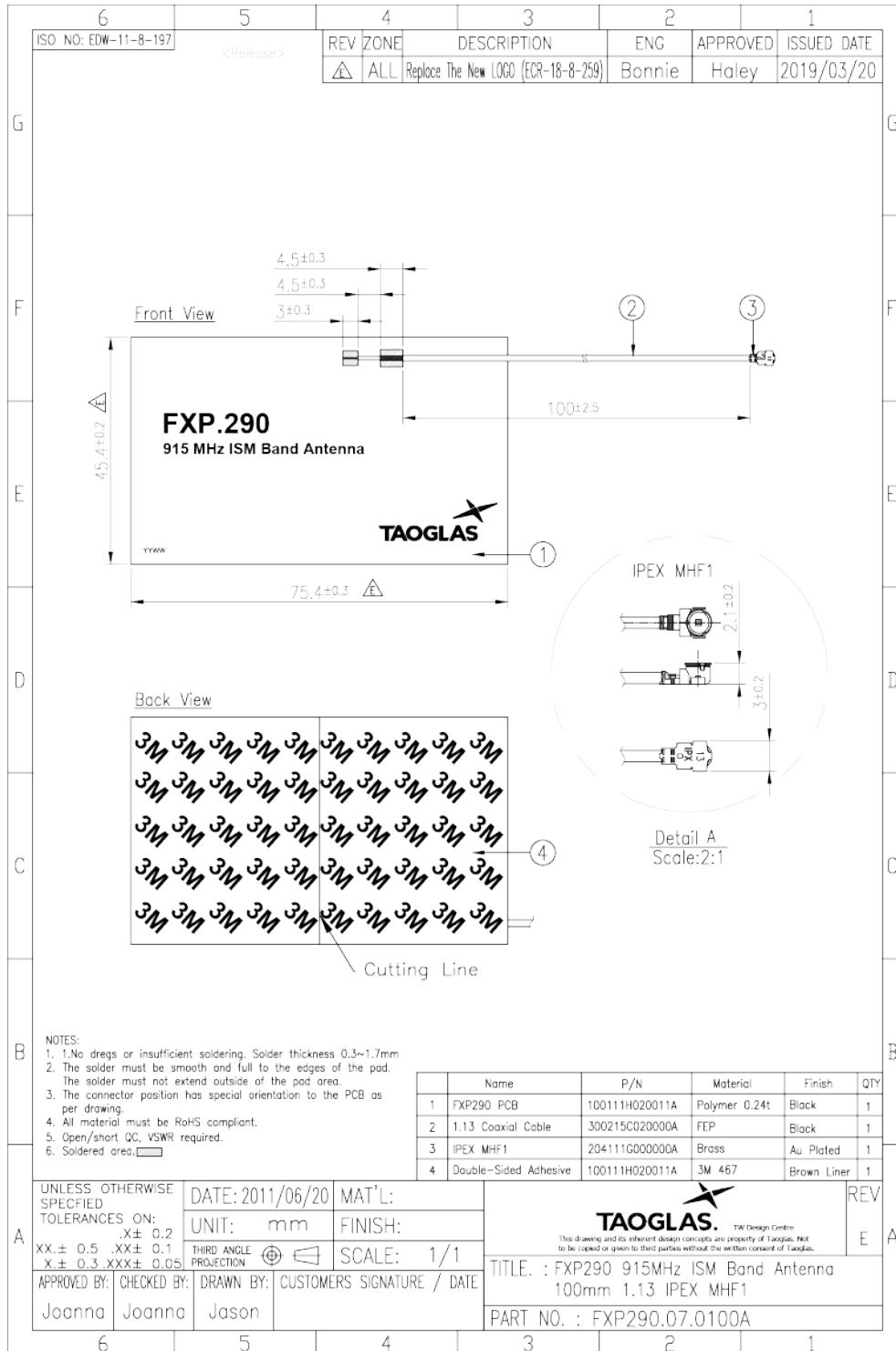

Figure 12. Mechanical Drawing for the FXP290 Antenna.

Taoglas makes no warranties based on the accuracy or completeness of the contents of this document and reserves the right to make changes to specifications and product descriptions at any time without notice. Taoglas reserves all rights to this document and the information contained herein.

Reproduction, use or disclosure to third parties without express permission is strictly prohibited.

© Taoglas