

TMCM-BB4

Hardware Version V1.1 | Document Revision V1.10 • 2022-11-22

The TMCM-BB4 is a 4-axis BaseBoard for Trinamic’s Slot Type Modules. It provides access to 4 + 1 Module slots. The single 36-pin PCI socket is available for the TMCM-0930 module, the main MCU (ARM Cortex-M4) module for the whole system. Other four 98-pin PCI sockets are accessible for Slot Type motor driver Modules, available as stepper (TMCM-1230;TMCM-1231) or BLDC (TMCM-1637;TMCM-1638) versions. This BaseBoard comes with communication interface options like CAN; RS485 and USB-C, plus separate GPIO headers for each insertable module.

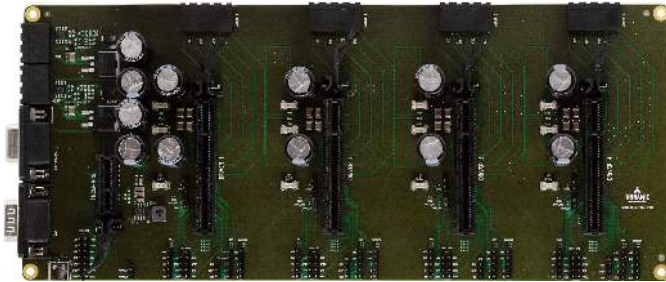

Features

- Board supply voltage: +24V and +48V DC options
- Standard PCI Express sockets for Slot Type Modules
- CAN, RS485, USB-C Interfaces
- Motor Connectors and GPIO headers for each stepper/BLDC motor driver slot

Applications

- Laboratory Automation
- Manufacturing
- Semiconductor Handling
- Robotics
- Factory Automation
- Test & Measurement
- Life Science
- Biotechnology
- Liquid Handling

Simplified Block Diagram

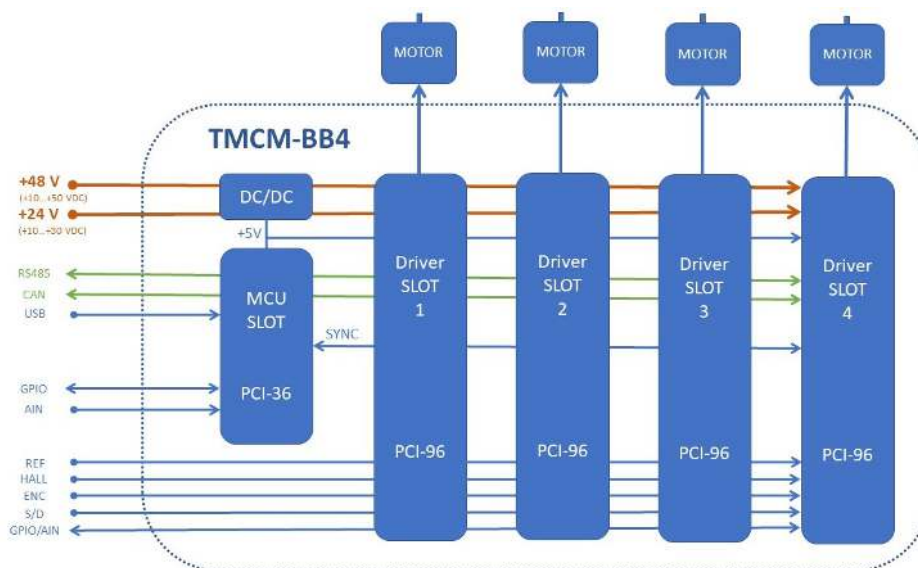

Contents

1	Getting Started	3
2	Connectors and Signals	4
2.1	Power supply and Communication Interface Connectors	5
2.2	Motor Connectors	6
2.3	GPIO Connectors	7
2.4	IO Description	10
2.5	Analog inputs AIN0 and AIN1	10
2.6	Digital inputs GPIO and GPI1	10
2.7	HOME/STOP_L/STOP_R switch inputs	10
2.8	Incremental encoder input	10
2.9	Hall sensor input	10
2.10	Step/Direction inputs	10
2.11	Address pins	10
3	Communication	12
3.1	RS485	12
3.2	CAN	13
4	Operational Ratings and Characteristics	15
5	Mechanical Characteristics	16
6	Revision History	18
6.1	Document Revision	18

1 Getting Started

You need

- TMCM-BB4
- TMCM-0930 MCU Module
- One or several Motor Driver Modules:
 - TMCM-1230 (+24V/5A Stepper)
 - TMCM-1231 (+48V/6.5A Stepper)
 - TMCM-1637 (+24V/5A BLDC)
 - TMCM-1638 (+48V/6.5A BLDC)
- Regulated Power Supply for:
 - +24** (+10...+30) VDC or
 - +48** (+10...+50) VDC
- Latest [TMCL-IDE](#)
- For TMCL and CAN firmware versions:
 - USB-2-RS485 adapter or CAN adapters

Precautions

- Do not mix up signals or short-circuit pins.
- Do not exceed the maximum rated supply supply voltage!
- **Start with power supply off!**

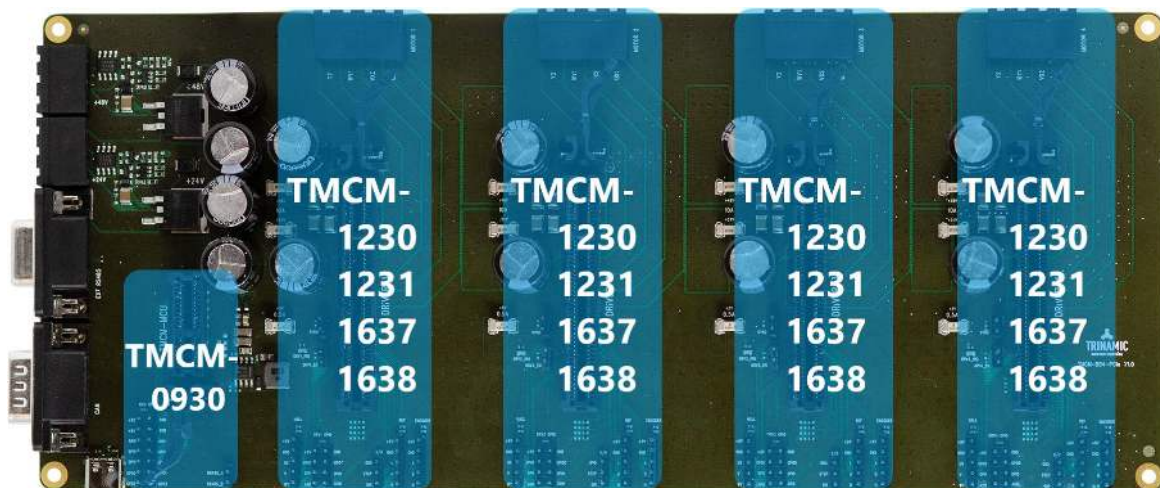

Figure 1: TMCM-BB4 Base board with available slots

NOTICE

Both supplies (+24 VDC and +48 VDC) are needed, if combination of +24V and +48V modules are used simultaneously. Each 98-pin PCI slot can be driven by either supply source.

2 Connectors and Signals

Figure 2 top view of the TMCM-BB4 shows two Power input connectors (2 x PT11503HBBN - marked red) and two Communication interface D-Sub connectors for RS485 and CAN (marked light blue). For the master MCU: PCIe 36-pin socket for MCU module (TMCM-0930 - marked in green), plus GPIO signal pin headers. For the Motor Drivers: PCIe 98-pin sockets (marked blue) and Motor Connectors (PT11504HBBN - marked pink), plus GPIO signal pin headers for each Driver Slot.

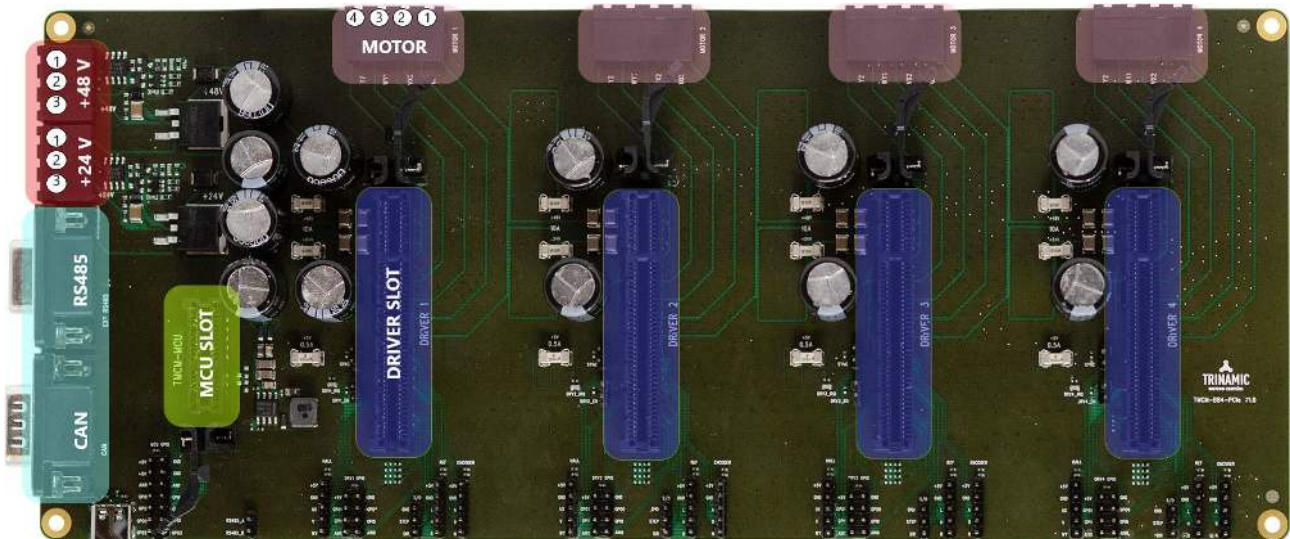

Figure 2: Top view of TMCM-BB4

Each connector has a small individual signal name marked in the silkscreen of the board , right next to the respective connectors' pin.

2.1 Power supply and Communication Interface Connectors

Connector Types and Mating Connectors		
Connector	Connector type on-board	Mating connector type
Power /+48V	PT11503HBBN (Type330, 3pins, 5mm pitch)	RP03503HBLC (Type313) RP03503HBLD (Type314)
Power /+24V	PT11503HBBN (Type330, 3pins, 5mm pitch)	RP03503HBLC (Type313) RP03503HBLD (Type314)
RS485	Female D-SUB 9pin receptable	Male D-SUB 9-pin plug
CAN	Male D-SUB 9-pin plug	Female D-SUB 9pin receptable
USB-C	USB-C female connector	USB-C male connector

Table 1: Connector Types and Mating Connectors of the TMCM-BB4



Figure 3: Power; Communication and USB-C connectors of TMCM-BB4

+48V 3pin POWER (Red) Connector Pin Assignment			
Pin no.	Pin name	Level	Description
1	GND	Power (GND)	Common system supply and signal ground
2	Brake	max. 30V	Brake Chopper for +24V
3	+48V	Supply	Supply voltage input (+10...+50 VDC)

Table 2: +24V Supply (Red) Pin Assignment

+24V 3pin POWER (Red) Connector Pin Assignment			
Pin no.	Pin name	Level	Description
1	GND	Power (GND)	Common system supply and signal ground
2	Brake	max. 50V	Brake Chopper for +48V
3	+24V	Supply	Supply voltage input (+10...+30 VDC)

Table 3: +48V Supply (Red) Pin Assignment

NOTICE

Always keep the power supply voltage below the upper limits of 30V and 50V! Otherwise the driver electronics fuses could be broken. Especially, when the selected operating voltage is near the upper limit a regulated power supply is highly recommended.

RS485 9-pin D-Sub Female Connector Pin Assignment			
Pin no.	Pin name	Level	Description
3	RS485-	+5 VDC	Bidirectional diff. RS485 bus signal (inverting)
5	GND	Power (GND)	Supply and signal ground connection
8	RS485+	+5 VDC	Bidirectional diff. RS485 bus signal (non-inverting)

Table 4: TMCM-BB4 RS485 D-Sub receptable pin assignment

CAN 9-pin D-Sub Male Connector Pin Assignment			
Pin no.	Pin name	Level	Description
2	CAN L	+5 VDC	Bidirectional diff. RS485 bus signal (inverting)
3	GND	Power (GND)	Supply and signal ground connection
7	CAN H	+5 VDC	Bidirectional diff. RS485 bus signal (non-inverting)

Table 5: TMCM-BB4 CAN D-Sub plug pin assignment

2.2 Motor Connectors

4pin PT11504HBBN MOTOR (Pink) Connectors Pin Assignment		
Pin no.	Pin name	Description
1	UX1	Motor phase A pin1 / BLDC U
2	VX2	Motor phase A pin2 / BLDC V
3	WY1	Motor phase B pin1 / BLDC W
4	Y2	Motor phase B pin2

Table 6: Motor (Pink) Pin Assignment

2.3 GPIO Connectors

The TMCM-BB4 offers separated GPIO headers for MCU module (purple) and Driver modules (yellow). The MCU GPIO 2x7pin header is situated below the 36-pin PCI socket and directly connected to the main MCU (MK20DX128VLK7) on the TMCM-0930. Right next to it, there is a 1x2pin header allowing direct access to internal RS485 BUS inbetween the Driver Slots. Right underneath each Driver's PCI 98-pin socket, five separated headers (yellow) with different GPIOs, ABN encoder inputs, Hall sensor inputs, Ref/stop/home inputs and S/D input can be found.

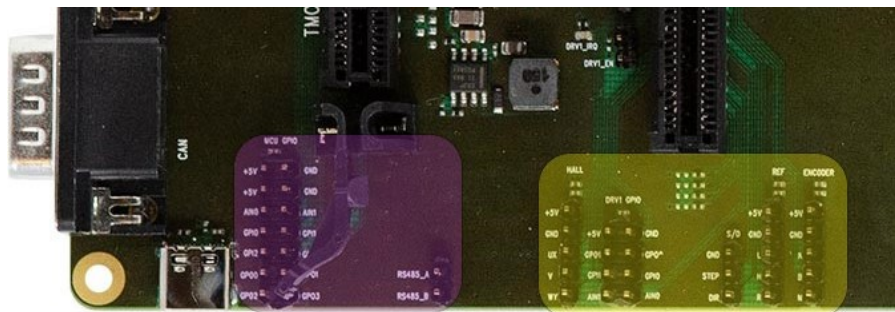

Figure 4: GPIO connectors of TMCM-BB4

Please check the online available design files and schematic data for additional information on the connectors' signal connections and pinning.

2x7pin MCU GPIO Header (Purple)			
Pin no.	Pin name	Level	Description
1	GPO 3	+5 VDC	MCU General purpose digital output 3
2	GPO 2	+5 VDC	MCU General purpose digital output 2
3	GPO 1	+5 VDC	MCU General purpose digital output 1
4	GPO 0	+5 VDC	MCU General purpose digital output 0
5	GPI 3	+5 VDC	MCU General purpose digital input 3
6	GPI 2	+5 VDC	MCU General purpose digital input 2
7	GPI 1	+5 VDC	MCU General purpose digital input 1
8	GPI 0	+5 VDC	MCU General purpose digital input 0
9	AIN 1	+5 VDC	MCU General purpose analog input 1
10	AIN 0	+5 VDC	MCU General purpose analog input 0
11	GND	Power (GND)	Common system supply and signal ground
12	+5V	+5 VDC	Common MCU-board +5V supply level
13	GND	Power (GND)	Common system supply and signal ground
14	+5V	+5 VDC	Common MCU-board +5V supply level

Table 7: 2x7pin MCU GPIO Header (Purple)

1x2pin Internal RS485 Bus Header (Purple)			
Pin no.	Pin name	Level	Description
1	RS485-	+5 VDC	Bidirectional diff. RS485 bus signal (inverting)
2	RS485+	+5 VDC	Bidirectional diff. RS485 bus signal (non-inverting)

Table 8: 1x2pin Internal RS485 Bus Header (Purple)

1x5pin Driver Hall sensor input Header (Yellow)			
Pin no.	Pin name	Level	Description
1	Hall WY	+5 VDC	Hall sensor input W
2	Hall V	+5 VDC	Hall sensor input V
3	Hall UX	+5 VDC	Hall sensor input U
4	GND	Power (GND)	Common system supply and signal ground
5	+5V	+5 VDC	Common Driver-board +5V supply level

Table 9: 1x5pin Driver Hall sensor input Header (Yellow)

2x4pin Driver GPIO Header (Yellow)			
Pin no.	Pin name	Level	Description
1	AIN 0	+5 VDC	Driver General purpose analog input 0
2	AIN 1	+5 VDC	Driver General purpose analog input 1
3	GPI 0	+5 VDC	Driver General purpose digital input 0
4	GPI 1	+5 VDC	Driver General purpose digital input 1
5	GPO 0	+5 VDC	Driver General purpose digital output 0
6	GPO 1	+5 VDC	Driver General purpose digital output 1
7	GND	Power (GND)	Common system supply and signal ground
8	+5V	+5 VDC	Common Driver-board +5V supply level

Table 10: 2x4pin Driver GPIO Header (Yellow)

1x3pin Driver S/D Header (Yellow)			
Pin no.	Pin name	Level	Description
1	GND	Power (GND)	Common system supply and signal ground
2	STEP	+5 VDC	Driver-board Step signal input
3	DIR	+5 VDC	Driver-board Direction signal input

Pin no.	Pin name	Level	Description
---------	----------	-------	-------------

Table 11: 1x3pin Driver S/D Header(Yellow)

1x5pin Driver Ref Header (Yellow)			
Pin no.	Pin name	Level	Description
1	STOP R	+5 VDC	Driver Right stop switch
2	HOME	+5 VDC	Driver Home switch
3	STOP L	+5 VDC	Driver Left stop switch
4	GND	Power (GND)	Common system supply and signal ground
5	+5V	+5 VDC	Common Driver-board +5V supply level

Table 12: 1x5pin Driver Ref Header (Yellow)

1x5pin Driver ABN Encoder input Header (Yellow)			
Pin no.	Pin name	Level	Description
1	ENC N	+5 VDC	Encoder signal null input
2	ENC B	+5 VDC	Encoder signal B input
3	ENC A	+5 VDC	Encoder signal A input
4	GND	Power (GND)	Common system supply and signal ground
5	+5V	+5 VDC	Common Driver-board +5V supply level

Table 13: 1x5pin Driver ABN Encoder input Header (Yellow)

1x2pin Driver Enable Jumper (Gray)			
Pin no.	Pin name	Level	Description
1	HIGH	+5 V	Resistor (100 Ohms) Pull-up for Driver Enable
2	ENABLE		Enable connected to each Driver's MCU and main MCU

Table 14: 1x2pin Driver Enable Jumper (Gray)

1x2pin Driver Sync Jumper (Gray)			
Pin no.	Pin name	Level	Description
1	HIGH	+5 V	Resistor (100 Ohms) Pull-up for Driver Sync
2	SYNC		Sync connected to each Driver's MCU and main MCU

Table 15: 1x2pin Driver Sync Jumper (Gray)

2.4 IO Description

Each Driver's slot connector offers two analog inputs, two digital inputs and digital outputs. All inputs can be used for different purposes explained in more detail in the following subsections.

2.5 Analog inputs AIN0 and AIN1

The TMCM-BB4 is equipped with two analog inputs, for each Driver slot. The analog input voltage range is approx. 0...+5V. For voltages above +5V saturation takes place but, up-to 30V higher voltages are tolerated without destroying the input. For analog to digital conversion the integrated ADC of the on-board microcontroller is used. Resolution of this converter is 12bit (0..4095).

The analog inputs can also be used as digital inputs.

2.6 Digital inputs GPIO and GPI1

The TMCM-BB4 offers two digital inputs per Driver GPIO and GPI1. Their input voltage range is 0...+5V. Higher voltages (up to 30V) are also tolerated without destroying the input. Voltages above 1V are recognized as logical '1' and below 1V as logical '0'.

2.7 HOME/STOP_L/STOP_R switch inputs

The TMCM-BB4 offers two inputs per Driver which can be used as left (STOP_L) and right (STOP_R) stop switch inputs. When enabled in software the STOP_L switch input will stop motor movement in negative direction (step counter decreasing) while activated. Likewise the STOP_R switch input will stop motor movement in positive direction (step counter increasing) while activated.

2.8 Incremental encoder input

An incremental A/B/N encoder can be connected to the encoder interface ENC_A, ENC_B and ENC_N. Encoder with push-pull signals (e.g. +5V TTL) and open-drain output signals are supported (single-ended). Each driver module is equipped with 4k7 pull-up resistors to +5V.

2.9 Hall sensor input

Hall sensor may be connected to the inputs HALL_U, HALL_V, HALL_W. The module is equipped with 4k7 pull-up resistors to +5V.

2.10 Step/Direction inputs

The Driver module may be used as driver with an external motion controller. In this case the Step/Direction output signals of the external motion controller may be connected to the Step/Dir inputs of the TMCM-BB4. Please note that these signals have to be TTL level signals.

2.11 Address pins

The address DIP-switch below each Driver slot includes signals ADDR0, ADDR1, ADDR2 and ADDR3 which can be used to set the TMCL module address or CANopen node ID of each module. This is useful when a base board with more than one slot is being used. In this case, every slot can be assigned to one specific TMCL module address or CANopen node ID by hardware.

When all address pins are pulled low, the address pins are not used. The TMCL module address or CANopen node ID stored in the EEPROM of the module will be used then. So in this case address / ID

settings will be set in software.

When at least one of the address pins is pulled high the address or ID set by the address pins will be used. With TMCL, the module address will be determined by the address pins (1... 15), and the reply address will always be 255. This is true for CAN and for RS485 communication. With CANopen, the node ID will be determined by the address pins (1... 15).

3 Communication

3.1 RS485

For remote control and communication the TMCM-BB4 provides a two wire RS485 bus interface. For proper operation the following items should be taken into account when setting up an RS485 network:

1. **BUS STRUCTURE:**

The network topology should follow a bus structure as closely as possible. That is, the connection between each node and the bus itself should be as short as possible. Basically, it should be short compared to the length of the bus.

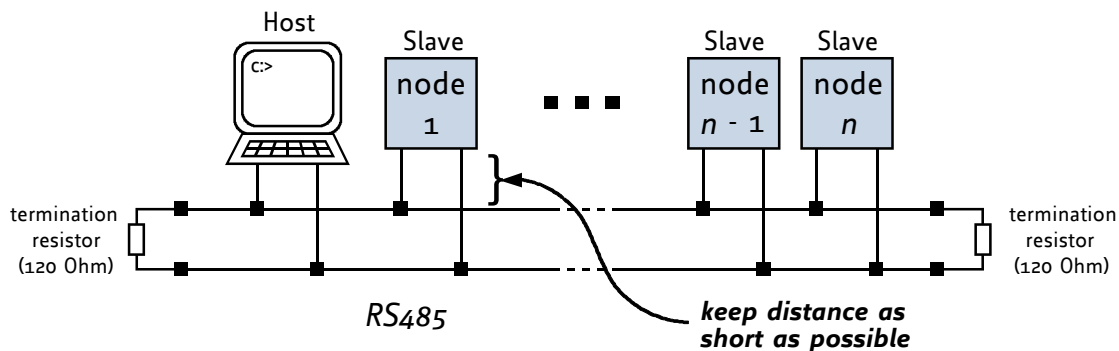

Figure 5: RS485 bus structure with termination resistors

2. **BUS TERMINATION:**

Especially for longer busses and/or multiple nodes connected to the bus and/or high communication speeds, the bus should be properly terminated at both ends. The TMCM-BB4 integrates a 120 Ohm termination resistor, at the end of last Driver socket. Therefore, another 120 Ohm termination resistors needs to be added to the bus externally.

3. **NUMBER OF NODES:**

The RS485 electrical interface standard (EIA-485) allows up to 32 nodes to be connected to a single bus. The bus transceiver used on the TMCM-BB4 units (SN65HVD1781D) offers a significantly reduced bus load compared to the standard and allows a maximum of 255 units to be connected to a single RS485 bus using standard TMCL firmware. *Please note: usually it cannot be expected to get reliable communication with the maximum number of nodes connected to one bus and maximum supported communication speed at the same time. Instead, a compromise has to be found between bus cable length, communication speed and number of nodes.*

4. **COMMUNICATION SPEED:**

The maximum RS485 communication speed supported by the TMCM-BB4 hardware is 1Mbit/s. Factory default is 9600 bit/s. Please see separate Slot Type Module TMCL firmware manual for information regarding other possible communication speeds below the upper hardware limit.

5. **NO FLOATING BUS LINES:**

Avoid floating bus lines while neither the host/master nor one of the slaves along the bus line is transmitting data (all bus nodes switched to receive mode). Floating bus lines may lead to communication errors. In order to ensure valid signals on the bus it is recommended to use a resistor network connecting both bus lines to well defined logic levels.

There are actually two options which can be recommended: Add resistor (bias) network on one side of the bus, only (120R termination resistor still at both ends):

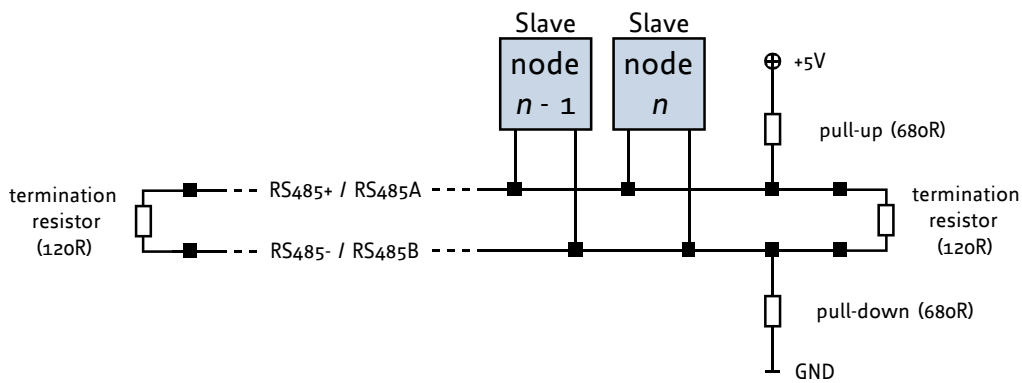

Figure 6: RS485 bus lines with resistor (bias) network on one side, only

Or add resistor network at both ends of the bus (like Profibus™ termination):

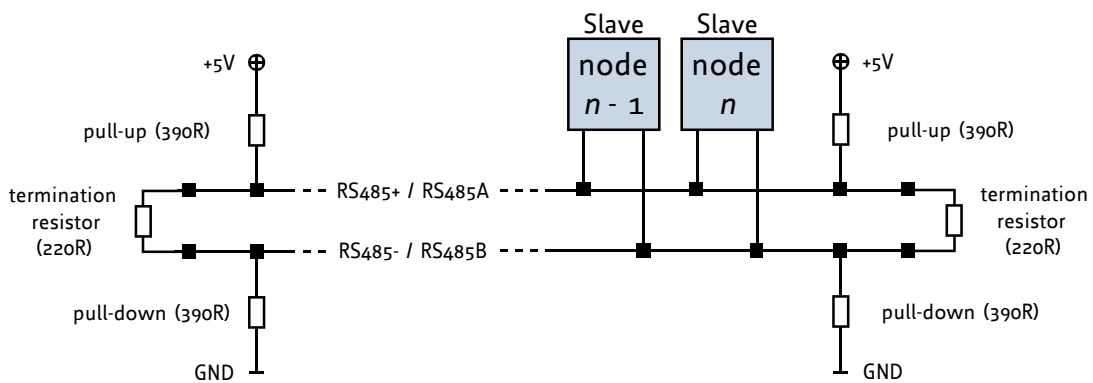

Figure 7: RS485 bus lines with Profibus™ recommended line termination

3.2 CAN

For remote control and communication with a host system the TMCM-BB4 provides a CAN bus interface. For proper operation the following items should be taken into account when setting up a CAN network:

1. **BUS STRUCTURE:**

The network topology should follow a bus structure as closely as possible. That is, the connection between each node and the bus itself should be as short as possible. Basically, it should be short compared to the length of the bus.

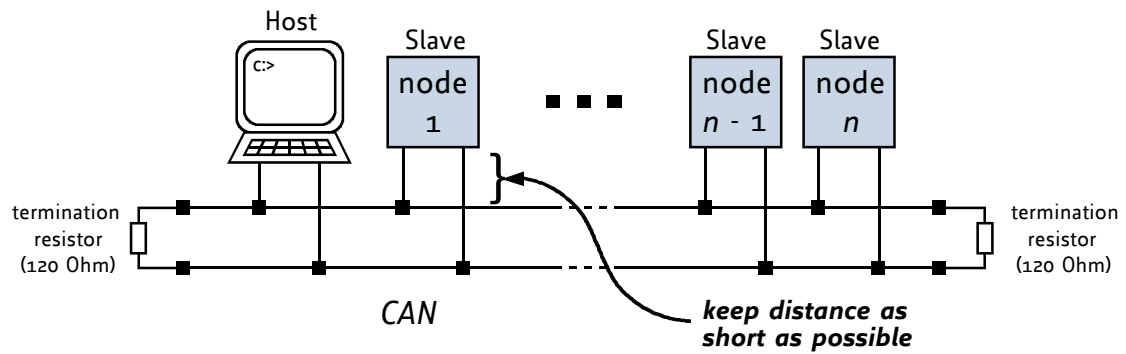

Figure 8: CAN bus structure with termination resistors

2. **BUS TERMINATION:**

Especially for longer busses and/or multiple nodes connected to the bus and/or high communication speeds, the bus should be properly terminated at both ends. The TMCM-BB4 includes one termination resistor at the end of the BUS. Therefore, additional 120 Ohm termination resistor has to be added externally.

3. **BUS TERMINATION:**

The bus transceiver used on the TMCM-BB4 units (TJA1051T) supports at least 110 nodes under optimum conditions. Practically achievable number of nodes per CAN bus highly depend on bus length (longer bus -> less nodes) and communication speed (higher speed -> less nodes).

4 Operational Ratings and Characteristics

NOTICE

Never Exceed the absolute maximum ratings! Keep the power supply voltages below the upper limits of +30V and +50V, depending on input connector! Otherwise the board's protective fuses or electronics on-board will be damaged! Especially, when the selected operating voltage is near the upper limit a regulated power supply is highly recommended.

General Operational Ratings					
Symbol	Parameter	Min	Typ	Max	Unit
V _{+24V}	Motor power supply voltage	10	12...24	30	V
V _{+48V}	Motor power supply voltage	10	24...48	50	V
I _{Motor}	Motor power supply current		<<I _{COIL_RMS}	1.4 × I _{COIL_RMS}	A
V _{Logic}	Logic power supply voltage		5		V
I _{Logic}	Logic power supply current		tbd		mA
I _{COIL_PEAK}	Motor coil current for sine wave peak (chopper regulated, adjustable via software)	0	0...7	7	A
I _{COIL_RMS}	Continuous motor current (RMS)	0	0...6.5	6.5	A
T _{ENV}	Environmental temperature at rated current (no forced cooling required)	-30		60	°C

Table 16: General operational ratings of the Driver modules

Operational Ratings of the I/Os					
Symbol	Parameter	Min	Typ	Max	Unit
V _{OUT}	Voltage at digital outputs GPO0 and GPO1	0		5	V
I _{OUT}	Current through GPO0 and GPO1			20	mA
V _{IN0/1/2/3}	Input voltage for inputs GPIO...GPIO3	0	0...5	5	V
V _{IN0/1}	Measurement range for analog inputs AIN0, AIN1	0		5	V
V _{IN1/2_L}	Low level voltage for GPIO...GPIO3 (digital inputs)			1	V
V _{IN1/2_H}	High level voltage for GPIO...GPIO3 (digital inputs)	2.9			V
V _{STOP_L/R_L}	Low level voltage for stop and home switch inputs		1		V
V _{STOP_L/R_H}	High level voltage for stop and home switch inputs	0	2.9		V
f _{STEP/DIR}	Max. frequency for step/direction inputs		250		kHz

Table 17: Operational ratings of I/Os

Operational Ratings of the RS485 Interface					
Symbol	Parameter	Min	Typ	Max	Unit
N_{RS485}	Number of nodes connected to single RS485 network			256	
f_{RS485}	Max. speed for RS485 network			1Mbit/s	

Table 18: Operational ratings of the RS485 interface

Operational Ratings of the CAN Interface					
Symbol	Parameter	Min	Typ	Max	Unit
N_{CAN}	Number of nodes connected to single CAN network			>110	
f_{CAN}	Max. speed for CAN network			1Mbit/s	

Table 19: Operational ratings of the CAN interface

5 Mechanical Characteristics

The maximum height of the BaseBoard with no Slot Type Modules is 27.55 ± 1 mm. The total height of the BaseBoard together with a Slot Type Modules is given by the length of the module + 5 mm. For example, the BaseBoard together with a TMC-1231 have a total height of 50 mm, while the TMC-1231 on its own has a short-side length of 45mm.

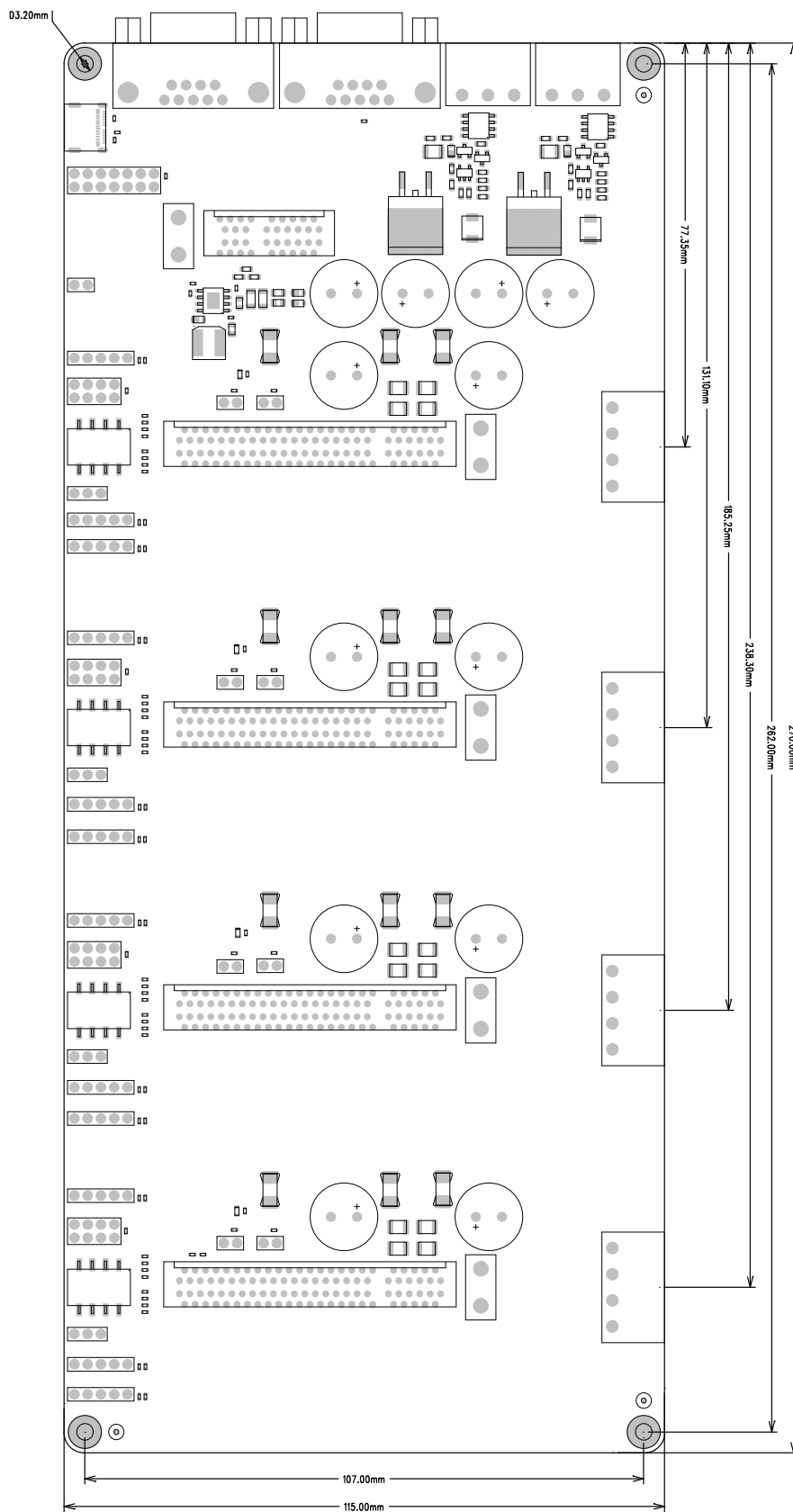

Figure 9: Top View, Mechanical Characteristics

6 Revision History

6.1 Document Revision

Version	Date	Author	Description
1.00	2020-11-09	HH	Initial release version.
1.10	2022-11-22	FV, DC	ADI Trinamic logo update and added Mechanical Characteristics section.

Table 20: Document Revision