



NJU7725x / NJU7726x

PRELIMINARY SPECIFICATIONS SUBJECT TO CHANGE

High-Speed, Rail-to-Rail Input, CMOS Comparator

FEATURES

- (V⁺ = 5V, Typical value, Ta = 25°C)
- Propagation Delay (T_{PLH} / T_{PHL})
 - NJU7725x 42ns / 35ns
 - NJU7726x 125ns / 32ns
- Rail-to-Rail Common-Mode Input Voltage Range
 - 0.2V beyond Supply Rails
- Dynamic Transient Stabilizer™
 - Rail-to-Rail Input with less propagation delay fluctuation
- Push-Pull Output (NJU7725x)
- Open-Drain Output (NJU7726x)
- Output Drive Current
 - Sink (V_O = 1V) 40mA
 - Source (V_O = 4V, NJU7725x) 37mA
- Supply Current 140μA/ch
- Supply Voltage 2.7V to 5.5V
- Operating Temperature -40°C to 125°C
- Lead-less Small Package
 - DFN6-G1 (ESON6-G1) (1.6 x 1.6 mm)
 - DFN8-U1 (ESON8-U1) (2.0 x 2.0 mm)
- Standard Small Package
 - SOT-23-5, SC-88A
 - MSOP8 (VSP8)

DESCRIPTION

The NJU7725x, NJU7726x series are Rail-to-Rail Input CMOS comparators featuring High-Speed. These comparators operate from 2.7V to 5.5V and low supply current of 140μA/ch. typ. This feature is suitable for battery powered application.

NJU7725x, NJU7726x series features the newly developed circuit technology Dynamic Transient Stabilizer™ realizes full swing input with suppressed fluctuation of propagation delay time.

In addition, the common mode input voltage range that exceeds the power supply voltage range is specified, and voltage detection near the power supply voltage is supported.

NJU7725x, NJU7726x series are available in ultra-small, leadless package measuring 1.6 mm x 1.6 mm (DFN6-G1) and 2.0 mm x 2.0 mm (DFN8-U1), and industrial standard leaded packages SOT-23-5, SC-88A, and MSOP8 (VSP8).

Dynamic Transient Stabilizer™ It is a circuit technology that suppresses fluctuations in propagation delay time even if the reference voltage for voltage detection fluctuates.

APPLICATIONS

- Protection circuit for overvoltage detection, overcurrent detection, overheat detection, etc.
- Window comparators
- LED drivers
- Relay drivers
- Electronic and electrical equipment in general
- Voltage Level Translators

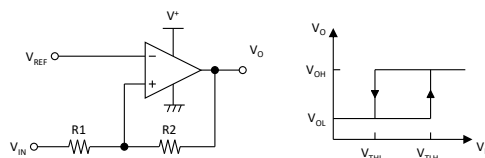
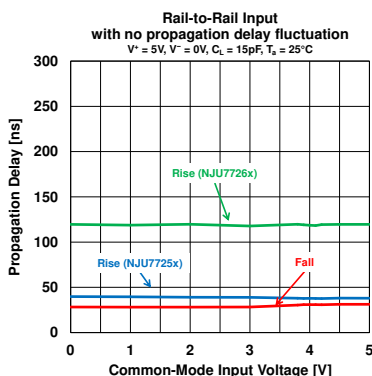

$$V_{TLH} = \frac{R1+R2}{R2} V_{REF} - \frac{R1}{R2} V_{OL}$$

$$V_{THL} = \frac{R1+R2}{R2} V_{REF} - \frac{R1}{R2} V_{OH}$$

Noninverting Comparator with Hysteresis

■ PRODUCT NAME INFORMATION

NJU772XX a (bbb)

Description of configuration

Suffix	Item	Description
a	Package code	Indicates the package. Refer to the order information.
bbb	Packing	Refer to the packing specifications.

■ ORDER INFORMATION

Product Name (Insert direction)	Package	RoHS	Halogen-Free	Terminal Finish	Marking	Weight (mg)	MOQ (pcs)
NJU77250F (TE1)	SOT-23-5	Yes	Yes	Sn2Bi	1S	15	3000
NJU77250F3 (TE1)	SC-88A	Yes	Yes	Sn2Bi	F5	7.5	3000
NJU77251F (TE1)	SOT-23-5	Yes	Yes	Sn2Bi	1U	15	3000
NJU77251F3 (TE1)	SC-88A	Yes	Yes	Sn2Bi	F6	7.5	3000
NJU77251KG1 (TE3)	DFN6-G1 (ESON6-G1)	Yes	Yes	Sn2Bi	77251	3.5	3000
NJU77260F (TE1)	SOT-23-5	Yes	Yes	Sn2Bi	1V	15	3000
NJU77260F3 (TE1)	SC-88A	Yes	Yes	Sn2Bi	F7	7.5	3000
NJU77261F (TE1)	SOT-23-5	Yes	Yes	Sn2Bi	1W	15	3000
NJU77261F3 (TE1)	SC-88A	Yes	Yes	Sn2Bi	F8	7.5	3000
NJU77261KG1 (TE3)	DFN6-G1 (ESON6-G1)	Yes	Yes	Sn2Bi	77261	3.5	3000
NJU77252R (TE1)	MSOP8 (VSP8)	Yes	Yes	Sn2Bi	77252	21	2000
NJU77252KU1 (TE3)	DFN8-U1 (ESON8-U1)	Yes	Yes	Sn2Bi	77252	5.3	3000
NJU77262R (TE1)	MSOP8 (VSP8)	Yes	Yes	Sn2Bi	77262	21	2000
NJU77262KU1 (TE3)	DFN8-U1 (ESON8-U1)	Yes	Yes	Sn2Bi	77262	5.3	3000

■ PIN DESCRIPTIONS

Product Name	NJU77250F NJU77260F	NJU77250F3 NJU77260F3	NJU77251F NJU77261F	NJU77251F3 NJU77261F3	NJU77251KG1 NJU77261KG1
Package	SOT-23-5	SC-88A	SOT-23-5	SC-88A	DFN6-G1 (ESON6-G1)
Pin Functions	<p>(Top View) OUTPUT 1, 5 V⁺ V⁻ 2 +INPUT 3, -INPUT 4</p>		<p>(Top View) +INPUT 1, 5 V⁺ V⁻ 2 -INPUT 3, OUTPUT 4</p>		<p>(Top View) V⁺ 1, 8 +INPUT N.C. 2, Exposed Pad on Underside V⁻ 7 OUTPUT 3, 6 -INPUT</p> <p>*Connect to exposed pad to V⁻</p>
Product Name	NJU77252R			NJU77252KU1	
Package	MSOP8 (VSP8)			DFN8-U1 (ESON8-U1)	
Pin Functions	<p>(Top View) A OUTPUT 1, 8 V⁺ A -INPUT 2, 7 B OUTPUT A +INPUT 3, 6 B -INPUT V⁻ 4, 5 B +INPUT</p>			<p>(Top View) A OUTPUT 1, 8 V⁺ A -INPUT 2, 7 B OUTPUT A +INPUT 3, 6 B -INPUT V⁻ 4, 5 B +INPUT</p> <p>*Connect to exposed pad to V⁻</p>	
Product Name	NJU77262R			NJU77262KU1(U.D.)	
Package	MSOP8 (VSP8)			DFN8-U1 (ESON8-U1)	
Pin Functions	<p>(Top View) A OUTPUT 1, 8 V⁺ A -INPUT 2, 7 B OUTPUT A +INPUT 3, 6 B -INPUT V⁻ 4, 5 B +INPUT</p>			<p>(Top View) A OUTPUT 1, 8 V⁺ A -INPUT 2, 7 B OUTPUT A +INPUT 3, 6 B -INPUT V⁻ 4, 5 B +INPUT</p> <p>*Connect to exposed pad to V⁻</p>	

■ BLOCK DIAGRAM

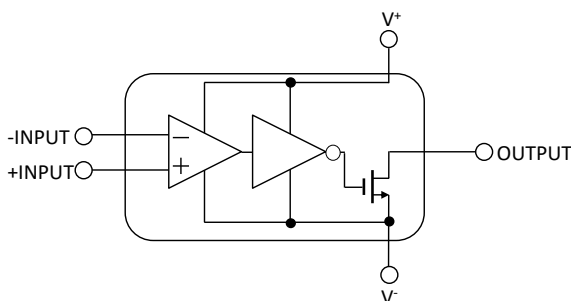

Open-Drain Output

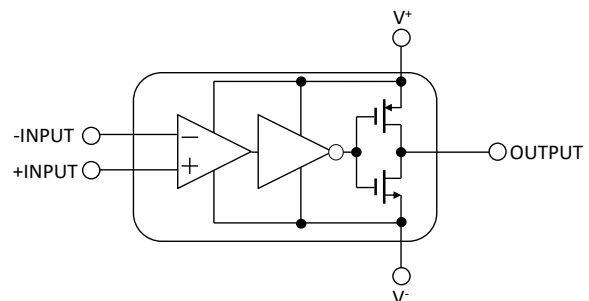

Push-Pull Output

■ ABSOLUTE MAXIMUM RATINGS

Parameter	Symbol	Rating	Unit
Supply Voltage	$V^+ - V^-$	7	V
Input Voltage (*1)	V_{IN}	$V^- - 0.3$ to $V^+ + 0.3$	V
Input Current (*1)	I_{IN}	± 10	mA
Differential Input Voltage (*2)	V_{ID}	± 7	V
Output Terminal Input Voltage (*3)	V_O	$V^- - 0.3$ to $V^+ + 0.3$ ^{*3}	V
		$V^- - 0.3$ to $V^- + 7$ ^{*4}	
Power Dissipation (Ta = 25°C)	P D	2-Layer / 4-Layer	
		480 ^{*5} / 650 ^{*5}	
		360 ^{*5} / 490 ^{*5}	
		330 ^{*6} / 1200 ^{*6}	
		500 ^{*5} / 660 ^{*5} 450 ^{*6} / 1200 ^{*6}	
Storage Temperature	T_{stg}	-65 to 150	°C
Junction Temperature	T_j	150	°C

*1 Input voltages outside the supply voltage will be clamped by ESD protection diodes. If the input voltage exceeds the supply voltage, the current must be limited 10 mA or less by using a restriction resistance. Input current inflow is positive and Input current outflow is negative. The input voltage is limited at 7V.

*2 Differential voltage is the voltage difference between +INPUT and -INPUT. The absolute maximum input voltage is limited at 7V.

*3 Rating of NJU7725X series. The output terminal input voltage is limited at 7V.

*4 Rating of NJU7726X series. The output terminal input voltage is limited at 7V.

*5 2-Layer: Mounted on glass epoxy board (76.2 mm × 114.3 mm × 1.6 mm: based on EIA/JEDEC standard, 2-layer FR-4).

4-Layer: Mounted on glass epoxy board (76.2 mm × 114.3 mm × 1.6 mm: based on EIA/JEDEC standard, 4-layer FR-4), internal Cu area: 74.2 mm × 74.2 mm.

*6 2-Layer: Mounted on glass epoxy board (101.5 mm × 114.5 mm × 1.6 mm: based on EIA/JEDEC standard, 2-layer FR-4) with exposed pad.

4-Layer: Mounted on glass epoxy board (101.5 mm × 114.5 mm × 1.6 mm: based on EIA/JEDEC standard, 4-layer FR-4) with exposed pad.

(For 4-layer: Applying 99.5 mm × 99.5 mm inner Cu area and a thermal via hole to a board based on JEDEC standard JESD51-5.)

ABSOLUTE MAXIMUM RATINGS

Electronic and mechanical stress momentarily exceeded absolute maximum ratings may cause permanent damage and may degrade the lifetime and safety for both device and system using the device in the field. The functional operation at or over these absolute maximum ratings is not assured.

■ THERMAL CHARACTERISTICS

Package	Measurement Result		Unit
	Thermal Resistance (Θ_{ja})	Thermal Characterization Parameter (ψ_{jt})	
SOT-23-5	260 ^{*7} /192 ^{*7}	67 ^{*7} / 58 ^{*7}	°C/W
SC-88A	347 ^{*7} /255 ^{*7}	91 ^{*7} / 73 ^{*7}	
DFN6-G1 (ESON6-G1)	379 ^{*8} /104 ^{*8}	64 ^{*8} / 26 ^{*8}	
MSOP8 (VSP8)	250 ^{*7} /189 ^{*7}	62 ^{*7} / 53 ^{*7}	
DFN8-U1 (ESON8-U1)	278 ^{*8} /104 ^{*8}	42 ^{*8} / 25 ^{*8}	

Θ_{ja} : Junction-to-Ambient Thermal Resistance

ψ_{jt} : Junction-to-Top Thermal Characterization Parameter

*7 2-Layer: Mounted on glass epoxy board (76.2 mm × 114.3 mm × 1.6 mm: based on EIA/JEDEC standard, 2-layer FR-4).

4-Layer: Mounted on glass epoxy board (76.2 mm × 114.3 mm × 1.6 mm: based on EIA/JEDEC standard, 4-layer FR-4), internal Cu area: 74.2 mm × 74.2 mm.

*8 2-Layer: Mounted on glass epoxy board (101.5 mm × 114.5 mm × 1.6 mm: based on EIA/JEDEC standard, 2-layer FR-4) with exposed pad.

4-Layer: Mounted on glass epoxy board (101.5 mm × 114.5 mm × 1.6 mm: based on EIA/JEDEC standard, 4-layer FR-4) with exposed pad.

(For 4-layer: Applying 99.5 mm × 99.5 mm inner Cu area and a thermal via hole to a board based on JEDEC standard JESD51-5.)

■ ELECTROSTATIC DISCHARGE (ESD) PROTECTION VOLTAGE

Parameter	Conditions	Protection Voltage
HBM	C = 100 pF, R = 1.5 kΩ	±1000 V
CDM	Direct CDM	±1000 V

ELECTROSTATIC DISCHARGE RATINGS

The electrostatic discharge test is done based on JEITA ED-4701.
In the HBM method, ESD is applied using the power supply pin and GND pin as reference pins.

■ RECOMMENDED OPERATING CONDITIONS

Parameter	Symbol	Conditions	Rating	Unit
Supply Voltage	$V^+ - V^-$		2.7 to 5.5	V
Input Voltage	V_{IN}		$V^- - 0.2$ to $V^+ + 0.2$ (MAX 5.5)	V
Output Terminal Input Voltage	V_O	NJU7726x	$V^- - 0.2$ to $V^- + 5.5$	V
Operating Temperature	T_{opr}		-40 to 125	°C

RECOMMENDED OPERATING CONDITIONS

All of electronic equipment should be designed that the mounted semiconductor devices operate within the recommended operating conditions. The semiconductor devices cannot operate normally over the recommended operating conditions, even if when they are used over such conditions by momentary electronic noise or surge. And the semiconductor devices may receive serious damage when they continue to operate over the recommended operating conditions.

■ ELECTRICAL CHARACTERISTICS

V⁺ = 5V, V⁻ = 0V, R_L = Open, T_a = 25°C, unless otherwise specified.

Parameter	Symbol	Test Conditions	Min	Typ	Max	Unit
INPUT CHARACTERISTICS^{*1}						
Input Offset Voltage	V _{IO}	V _{COM} = -0.2V	-	1	7	mV
		V _{COM} = 5.2V	-	1	9	mV
Input Bias Current	I _B		-	1	-	pA
Input Offset Current	I _{IO}		-	1	-	pA
Common-Mode Input Voltage Range	V _{ICM}	CMR ≥ 55dB	-0.2	-	5.2	V
Common-Mode Rejection Ratio	CMR	V _{ICM} = -0.2V to 5.2V	55	70	-	dB
OUTPUT CHARACTERISTICS						
High-level Output Voltage (NJU7725x)	V _{OH}	I _{SOURCE} = 4mA	4.8	4.9	-	V
Low-level Output Voltage	V _{OL}	I _{SINK} = 4mA	-	0.1	0.2	V
Output Leakage Current (NJU7726x)	I _{LEAK}	V _O = 5V	-	1	700	nA
Output Short-Circuit Current (NJU7725x)	I _{SC}	I _{SOURCE} , V _O = 0V	-	85	-	mA
Output Short-Circuit Current	I _{SC}	I _{SINK} , V _O = 5V	-	65	-	mA
POWER SUPPLY						
Supply Current per Comparator	I _{SUPPLY}	V _{COM} = -0.2V	-	140	210	μA
		V _{COM} = 5.2V	-	200	300	μA
Supply Voltage Rejection Ratio	SVR	V ⁺ = 2.7V to 5.5V	60	85	-	dB
Transient Response (R_L = 5.1kΩ, C_L = 15pF, Overdrive = 100mV)						
(NJU7725x)						
Propagation Delay (Low to High)	t _{PLH}		-	42	-	ns
Propagation Delay (High to Low)	t _{PHL}		-	35	-	ns
Rise Time	t _{TLH}		-	4.0	-	ns
Fall Time	t _{THL}		-	3.5	-	ns
(NJU7726x)						
Propagation Delay (Low to High)	t _{PLH}		-	125	-	ns
Propagation Delay (High to Low)	t _{PHL}		-	32	-	ns
Rise Time	t _{TLH}		-	250	-	ns
Fall Time	t _{THL}		-	2	-	ns

^{*1} Input offset voltage and drift, Input bias and offset current are positive or negative, its absolute values are listed in electrical characteristics.

■ APPLICATION NOTE

Single and Dual Supply Voltage Operation

Single and Dual Supply Voltage Operation
 The NJU7725x, NJU7726x series works with both single supply and dual supply when the voltage supplied is between V^+ and V^- . These comparators operate from single 2.7V to 5.5V supply and dual $\pm 1.35V$ to $\pm 2.75V$ supply. The power supply pin should have bypass capacitor (i.e. 0.1 μ F).

Input Voltage

The NJU7725x, NJU7726x series are Rail-to-Rail input comparators. The common mode input voltage range is $V^- - 0.2V$ to $V^+ + 0.2V$, and the differential input voltage can be any voltage within supply voltage. No phase inversion of the comparator output occurs when the input range of $V^- - 0.2V$ to $V^+ + 0.2V$.

Inputs of the NJU7725x, NJU7726x series are protected by ESD diodes (shown in Figure 1) that will conduct if the input voltages exceed the power supplies by more than approximately 300mV. Momentary voltages greater than 300mV beyond the power supply, inputs can be tolerated if the current is limited to 10mA.

Figure 2 is simple accomplished with an input resistor. If the input voltage exceeds the supply voltage, the input current must be limited 10mA or less by using a restriction RLIMIT as shown in figure 2.

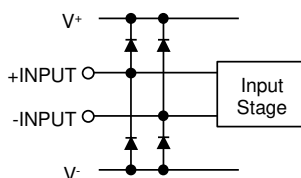

Figure 1. Simplified Schematic

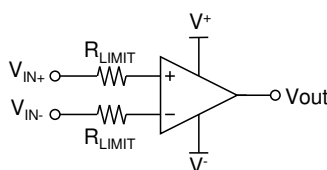

Figure 2. Input Current Protection for Voltages exceeding the Supply Voltage.

Output Voltage

The NJU7725x series features a push-pull output. The output logic level is the same as the supply rail. The circuit can be simplified without the need for an external pull-up resistor.

The NJU7726x series has an open drain output. It can be pulled up to an external power supply up to $V^- + 5.5V$ independent of supply voltage. It can be applied to window comparators and logic level converter.

Dynamic Transient Stabilizer™

The NJU7725x and NJU7726x series use the new circuit technology Dynamic Transient Stabilizer™ to realize a rail-to-rail input that suppresses fluctuations in propagation delay.

A general rail-to-rail input comparator operates within the supply rails, but when the input signal level is close to the supply voltage, the propagation delay will decrease and may not be as designed.

Figure 3 compares the NJU7725x and NJU7726x with a conventional rail-to-rail input comparators. Conventional comparators have a delay of 20 ns close to the supply voltage. This change in propagation delay requires a review of the design margin, which increases the design period.

By using the NJU7725x and NJU7726x series with Dynamic Transient Stabilizer™, stable response can be obtained in any voltage within supply voltage.

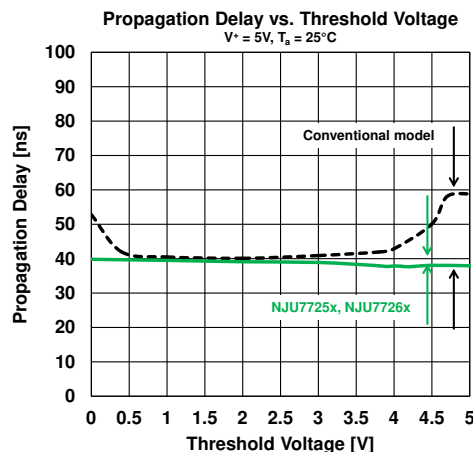
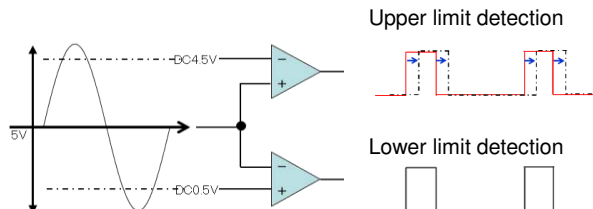

Figure 3. Propagation delay vs. Threshold Voltage

Figure 4 shows a window comparator circuit using the NJU7726x series. Even if the threshold setting is set near the power supply voltage, stable operation can be performed without delay in response time.



In conventional comparators, the upper limit detection was changed.
 -> Lower limit detection and upper limit detection are different.

Figure 4. Level detection circuit using window comparator

■ APPLICATION NOTE

Terminating unused comparators

Examples of common methods of terminating an uncommitted comparator are shown in Figure 5. Improper termination can result in increased supply current, heating and noise in comparators.

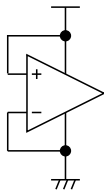

Figure 5. Terminating unused comparators

External Hysteresis

The comparator can change the threshold by using positive feedback. The difference in threshold voltage is called hysteresis, which can improve noise immunity and operation for low-speed signals.

Noninverting Comparator with Hysteresis

Figure 6 shows a hysteresis comparator circuit with two resistors. Assuming that the threshold at which the comparator output is Low-High is V_{TLH} and the threshold at which the comparator output is High-Low is V_{THL} , to achieve the following hysteresis are below.

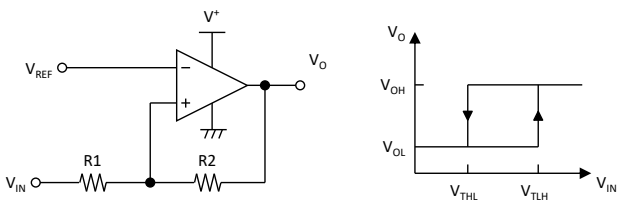

$$V_{TLH} = \frac{R1+R2}{R2} V_{REF} - \frac{R1}{R2} V_{OL}$$

$$V_{THL} = \frac{R1+R2}{R2} V_{REF} - \frac{R1}{R2} V_{OH}$$

Figure 6. Noninverting Comparator with Hysteresis

Inverting Comparator with Hysteresis

Figure 7 shows a hysteresis comparator circuit with three resistors.

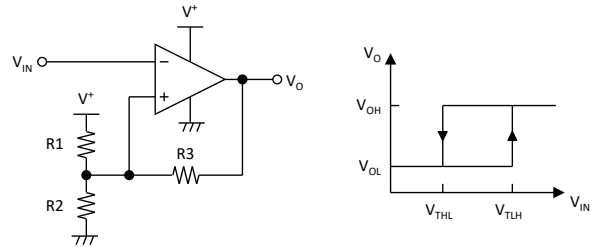
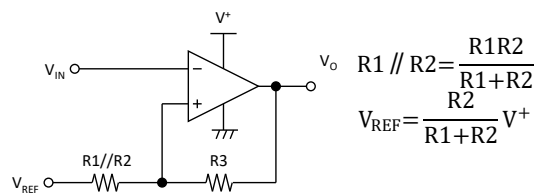

Figure 7. Inverting Comparator with Hysteresis

If R1 and R2 of the circuit in Figure 7 are represented by equivalent resistors, the circuit will be as shown in Figure 8. Since this circuit is the same as the noninverting hysteresis comparator, V_{TLH} and V_{THL} can be calculated by rearranging the equations.



$$R1 // R2 = \frac{R1R2}{R1+R2}$$

$$V_{REF} = \frac{R2}{R1+R2} V^+$$

$$V_{TLH} = \frac{R1 // R2}{R1 // R2 + R3} V_{REF} + \frac{R1 // R2}{R1 // R2 + R3} V_{OL}$$

$$V_{THL} = \frac{R1 // R2}{R1 // R2 + R3} V_{REF} + \frac{R1 // R2}{R1 // R2 + R3} V_{OH}$$

Figure 8. Noninverting hysteresis comparator as equivalent circuits

■ APPLICATION NOTE

Window Comparator

By using the open drain type NJU7726x in parallel, it is achieve to detect whether the signal is between two reference voltages. This circuit is commonly called a window comparator and can be used for monitoring the reference voltage and monitoring abnormal voltages such as signal voltage drop or overvoltage.

Figure 9 shows a simple window comparator circuit. The comparator output V_O is High only when V_{IN} is between V_{REF1} and V_{REF2} , and Low otherwise. If chattering occurs during the output shift period, connect capacitors in parallel with R1 and R3.

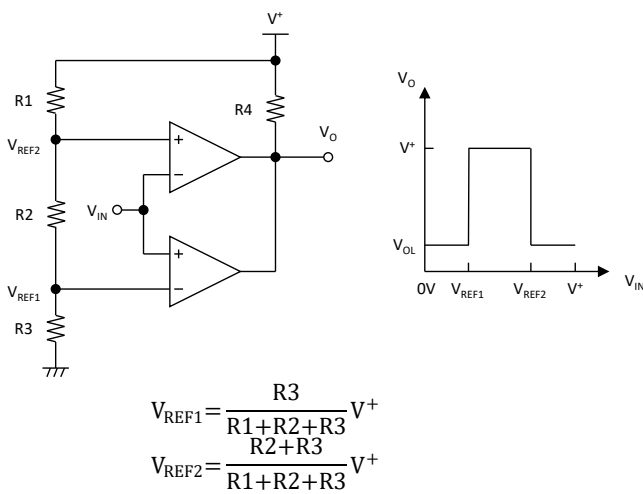

Figure 9. Window Comparator with NJU7726x

Example)

Assuming $V^+ = 3.3V$, $R1 = R2 = R3 = 1M\Omega$, $R4 = 10k\Omega$, the thresholds from the formula in Figure 9 are $V_{REF1} = 1.1V$, $V_{REF2} = 2.2V$. V_O is Low when $V_{IN} < 1.1V$ or $V_{IN} > 2.2V$, and V_O is High when V_{IN} is between 1.1V and 2.2V (Figure 10).

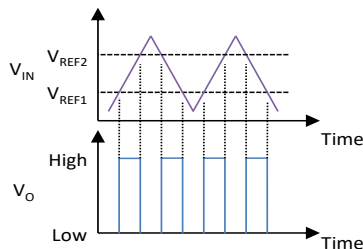

Figure 10. Window comparator output results

Square Wave Oscillator

Figure 11 shows a simple square wave oscillator circuit. It can be used to digital circuits such as microcomputers, oscillation circuits, timing waveforms, and driver circuits for electronic buzzers.

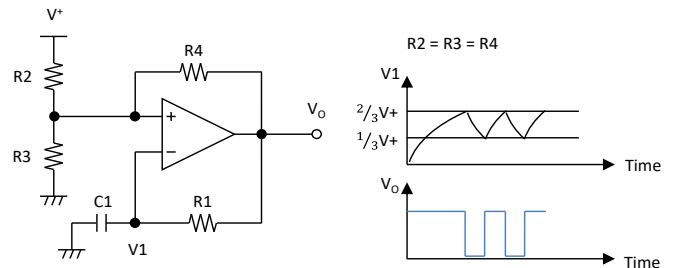

Figure 11. Square Wave Oscillator

When $R2 = R3$, the oscillator circuit has 50% duty, and the oscillation frequency is as follows.

$$f = \frac{1}{2R1C1 \ln \left(1 + \frac{R4}{R3} \right)} \text{ [Hz]}$$

$R2=R3$

$R4$ sets the threshold of the comparator that switches between charging and discharging to C1. If $R2 = R3 = R4$, the oscillation frequency is as follows.

$$f = \frac{1}{2R1C1 \ln 2} \text{ [Hz]}$$

$R2=R3=R4$

■ TYPICAL CHARACTERISTICS

Note: Typical Characteristics are intended to be used as reference data; they are not guaranteed.

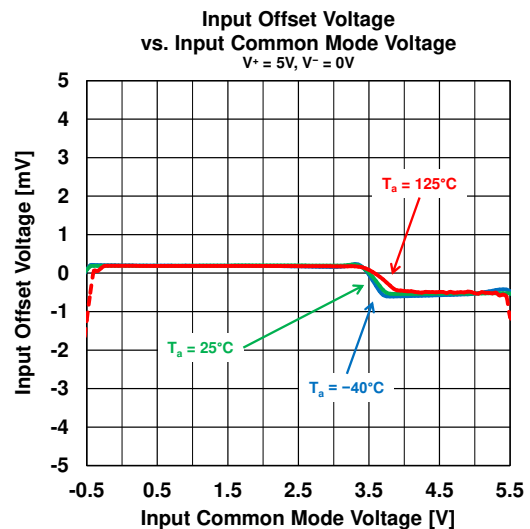
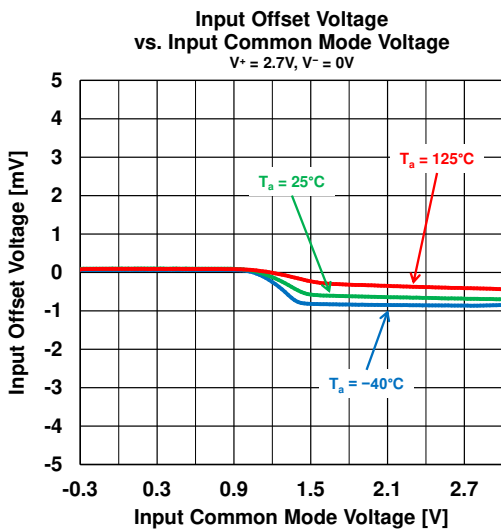
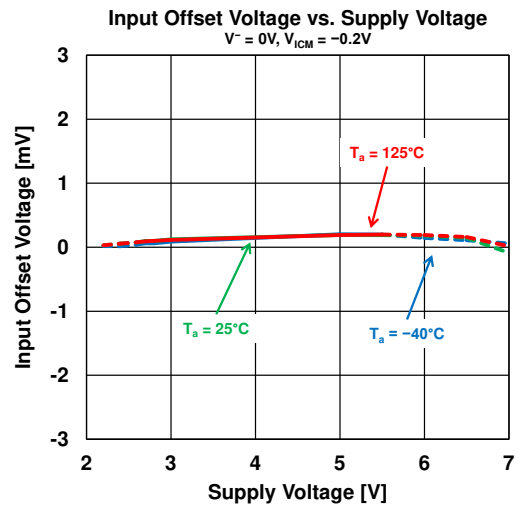
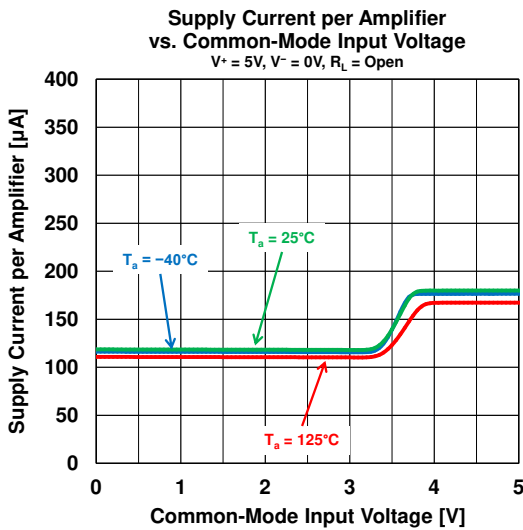
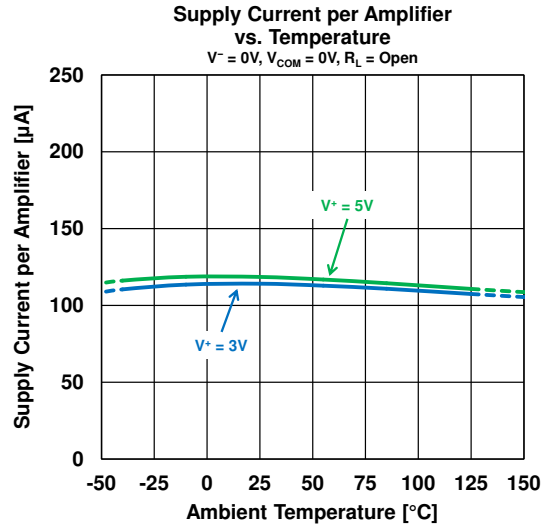
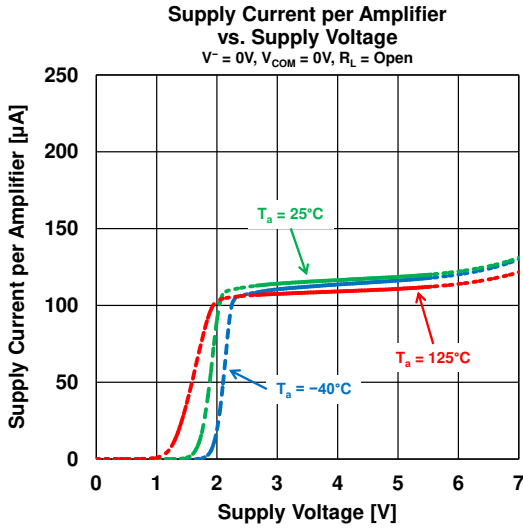

■ TYPICAL CHARACTERISTICS

Note: Typical Characteristics are intended to be used as reference data; they are not guaranteed.

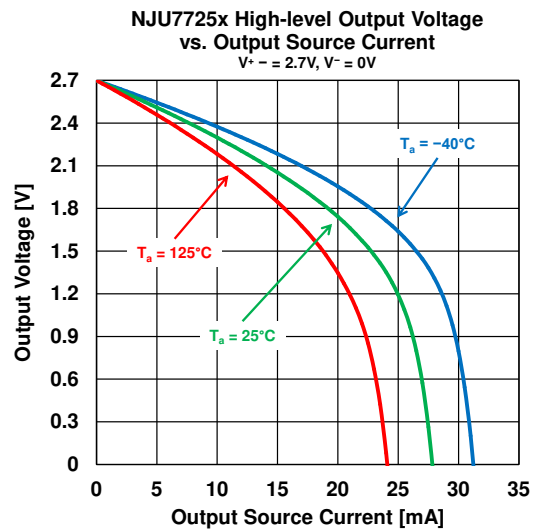
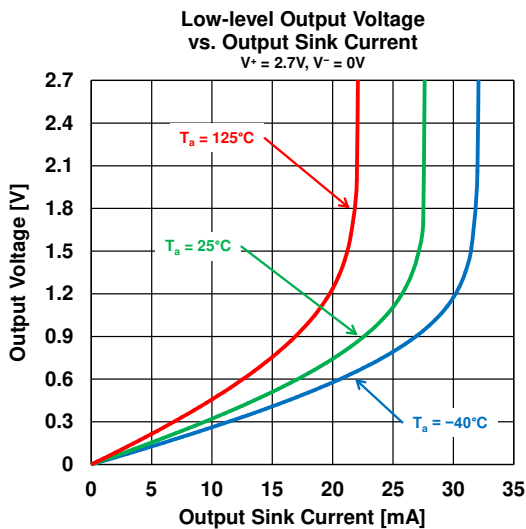
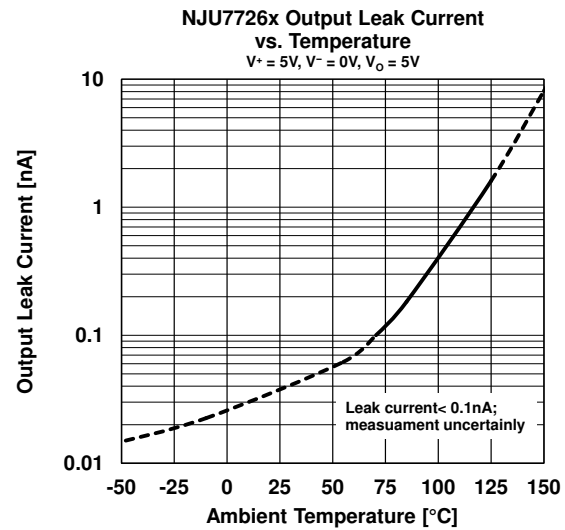
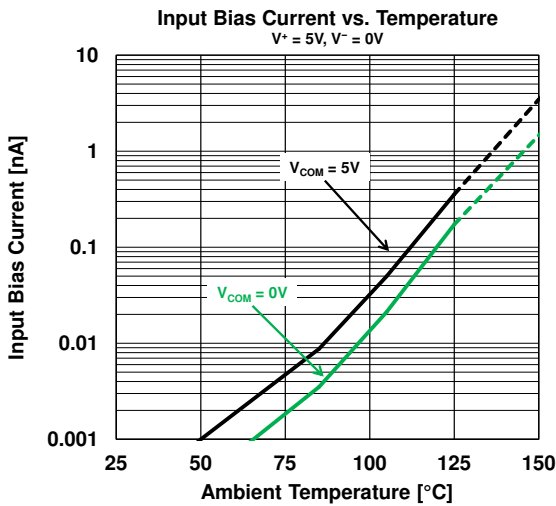
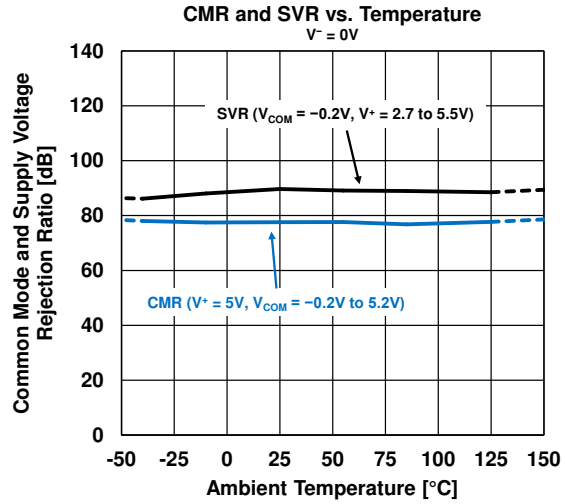
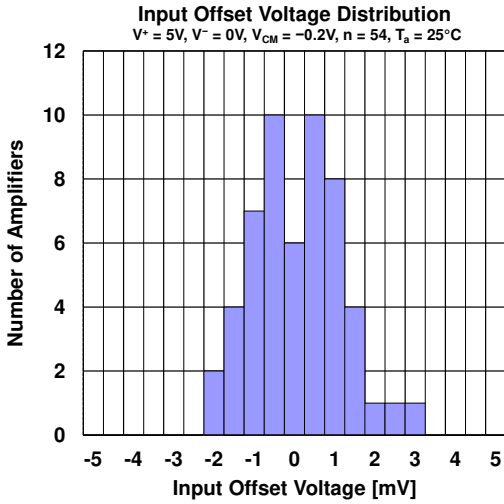

■ TYPICAL CHARACTERISTICS

Note: Typical Characteristics are intended to be used as reference data; they are not guaranteed.

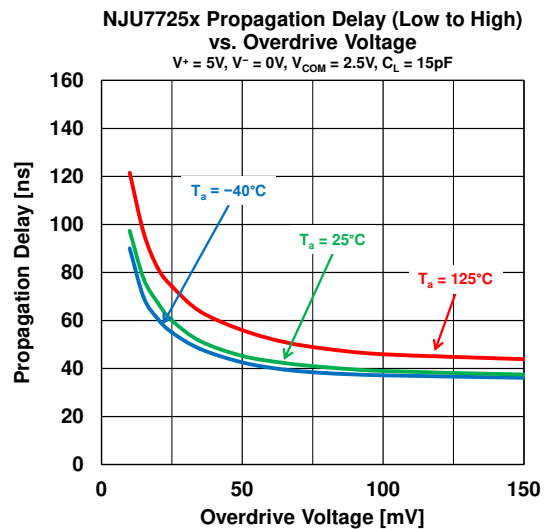
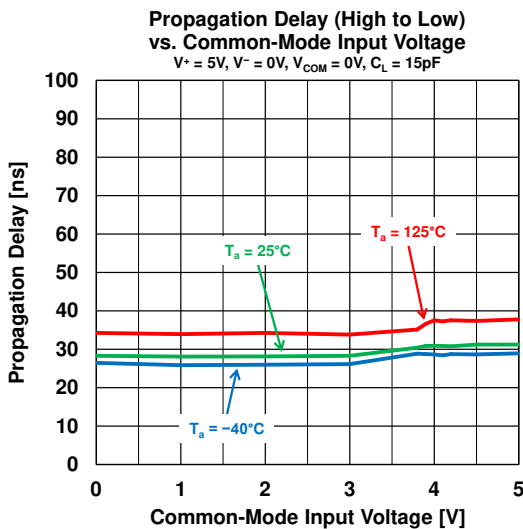
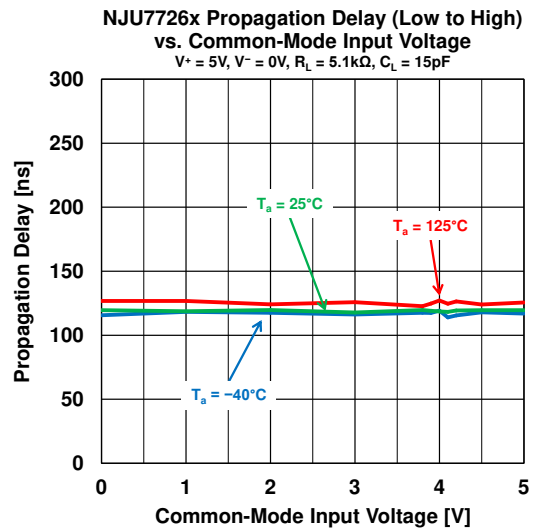
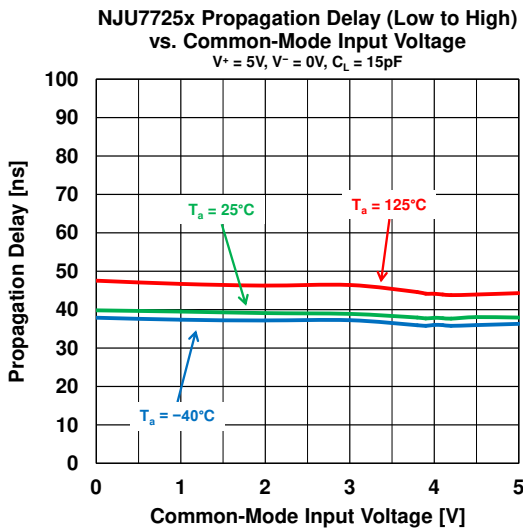
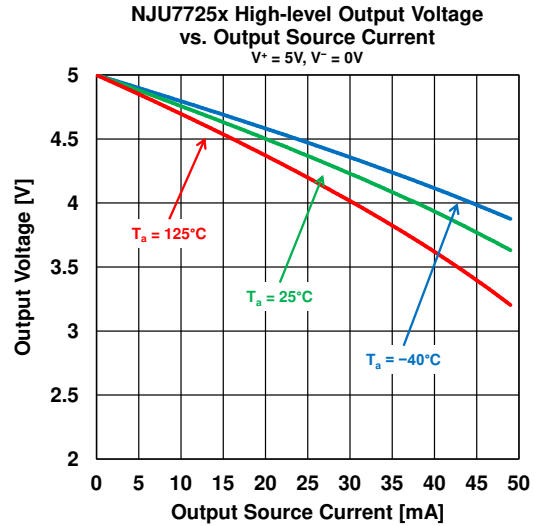
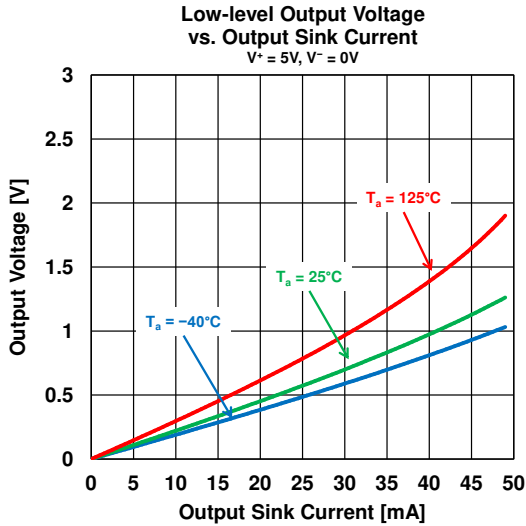

■ TYPICAL CHARACTERISTICS

Note: Typical Characteristics are intended to be used as reference data; they are not guaranteed.

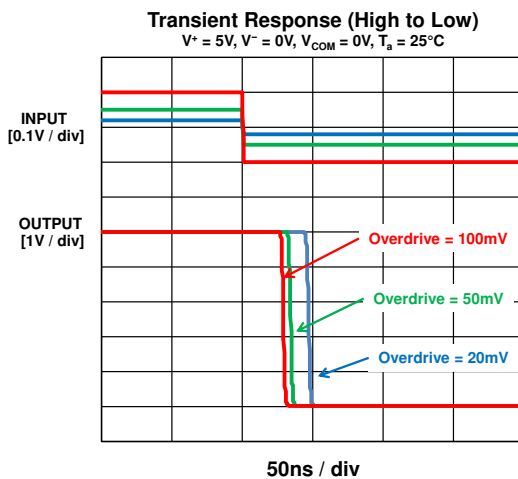
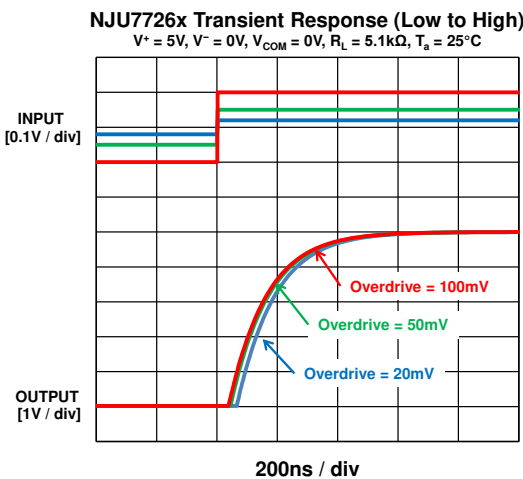
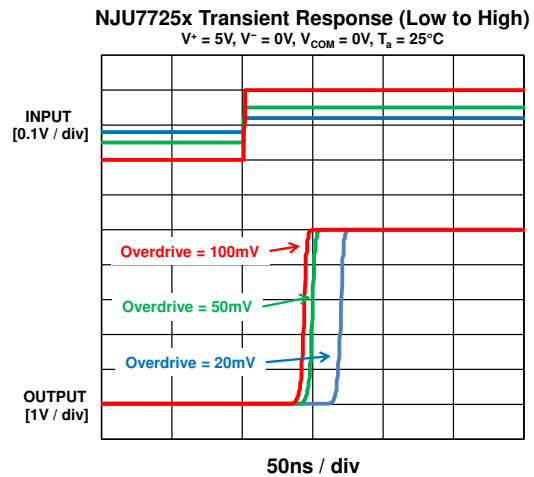
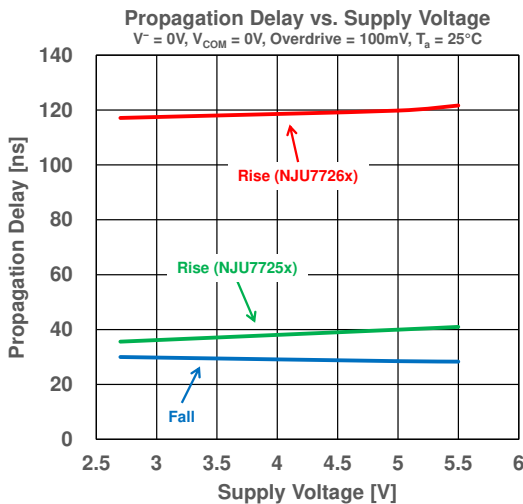
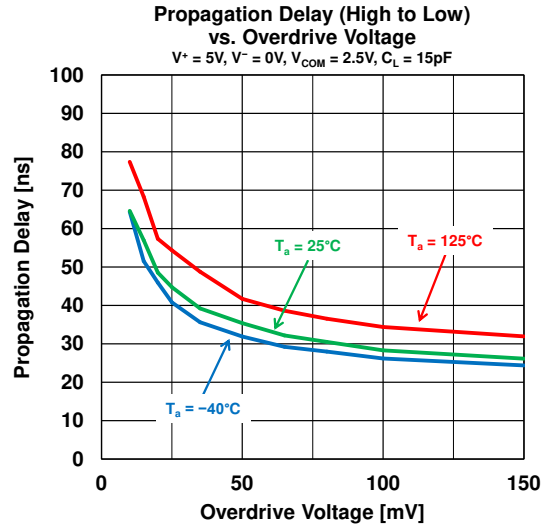
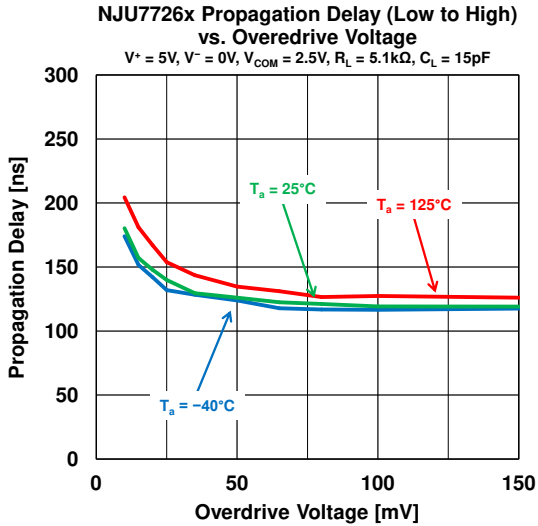

■ TEST CIRCUITS

● I_{SUPPLY}

V_{ID} = 100mV

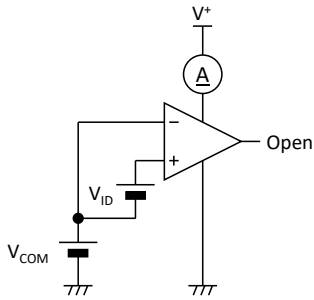

● V_{OH}

V_{ID} = 100mV

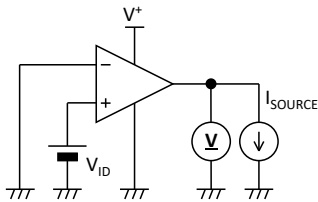

● V_{OL}

V_{ID} = 100mV

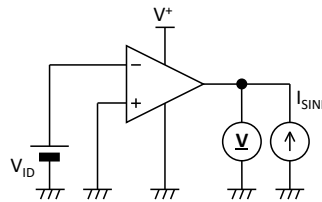

● Propagation Delay

R_L = 5.1kΩ, V_{COM} = 0V, V⁺

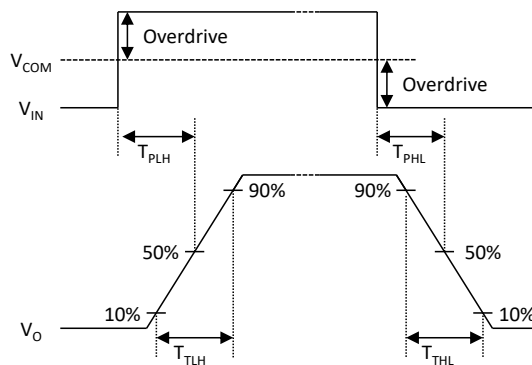
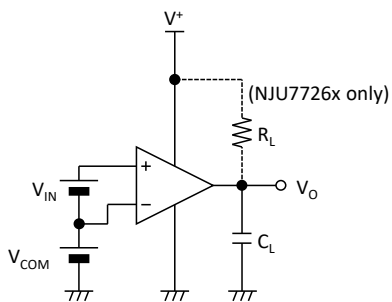

■ REVISION HISTORY

Date	Revision	changes
August 31, 2020	Ver.0.0	Initial Release
August 19, 2021	Ver.0.1	Added NJU7726x series Added Application Note.
September 22, 2021	Ver.0.2	Updated Descriptions.
June 30, 2022	Ver.0.3	Updated Format Development status update

■ PACKAGE DIMENSIONS

UNIT: mm

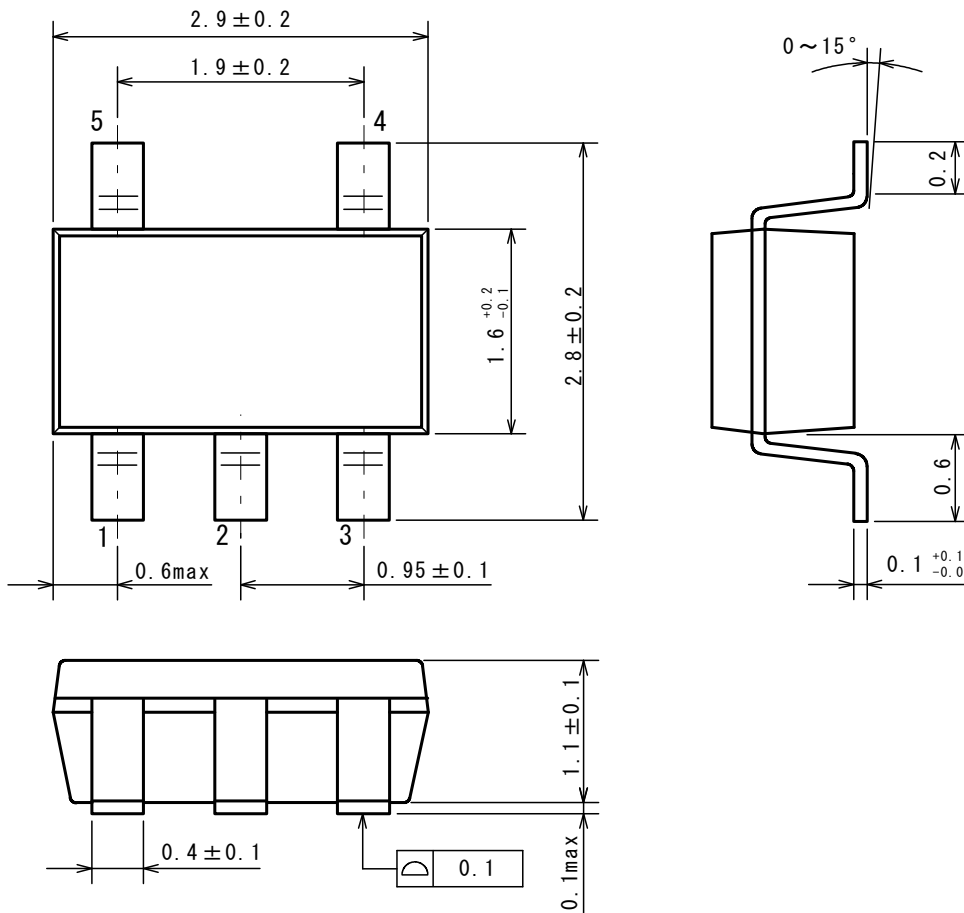

■ EXAMPLE OF SOLDER PADS DIMENSIONS

UNIT: mm

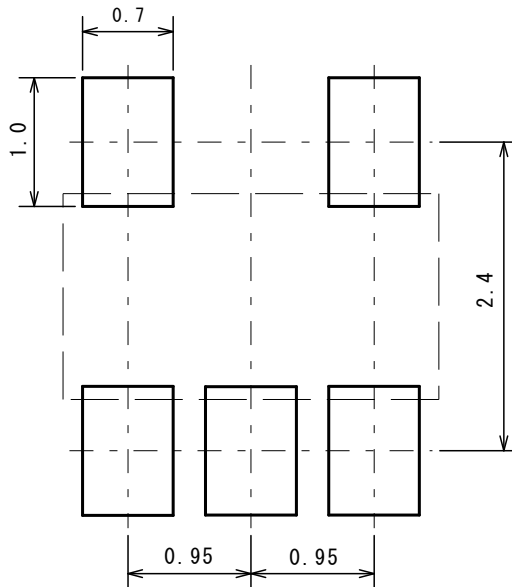

Nisshinbo Micro Devices Inc.

SOT-23-5

PI-SOT-23-5-E-A

■ PACKING SPEC

UNIT: mm

TAPING DIMENSIONS

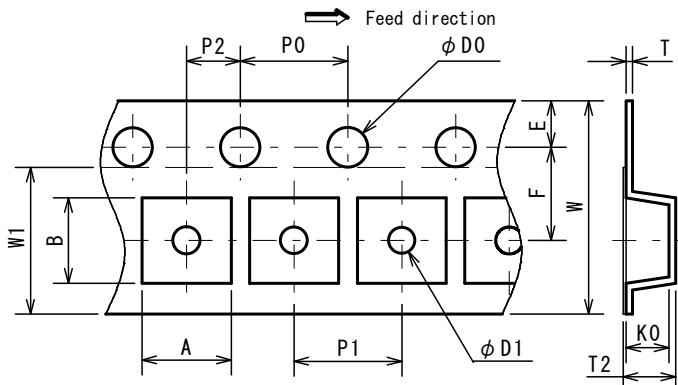

SYMBOL	DIMENSION	REMARKS
A	3.3±0.1	BOTTOM DIMENSION
B	3.2±0.1	BOTTOM DIMENSION
D0	1.55	
D1	1.05	
E	1.75±0.1	
F	3.5±0.05	
P0	4.0±0.1	
P1	4.0±0.1	
P2	2.0±0.05	
T	0.25±0.05	
T2	1.82	
K0	1.5±0.1	
W	8.0±0.3	
W1	5.5	THICKNESS 0.1MAX

REEL DIMENSIONS

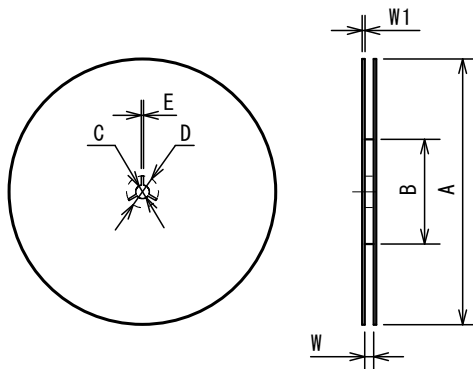

SYMBOL	DIMENSION
A	φ 180±1
B	φ 60±1
C	φ 13±0.2
D	φ 21±0.8
E	2±0.5
W	9±0.5
W1	1.2±0.2

TAPING STATE

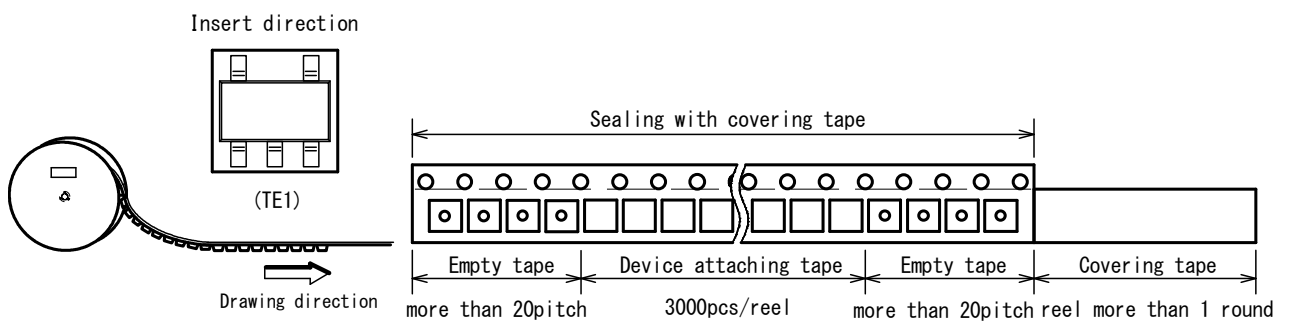

PACKING STATE

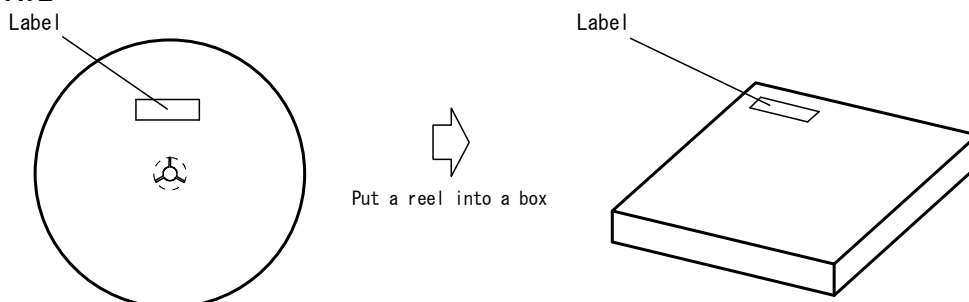

■ PACKAGE DIMENSIONS

UNIT: mm

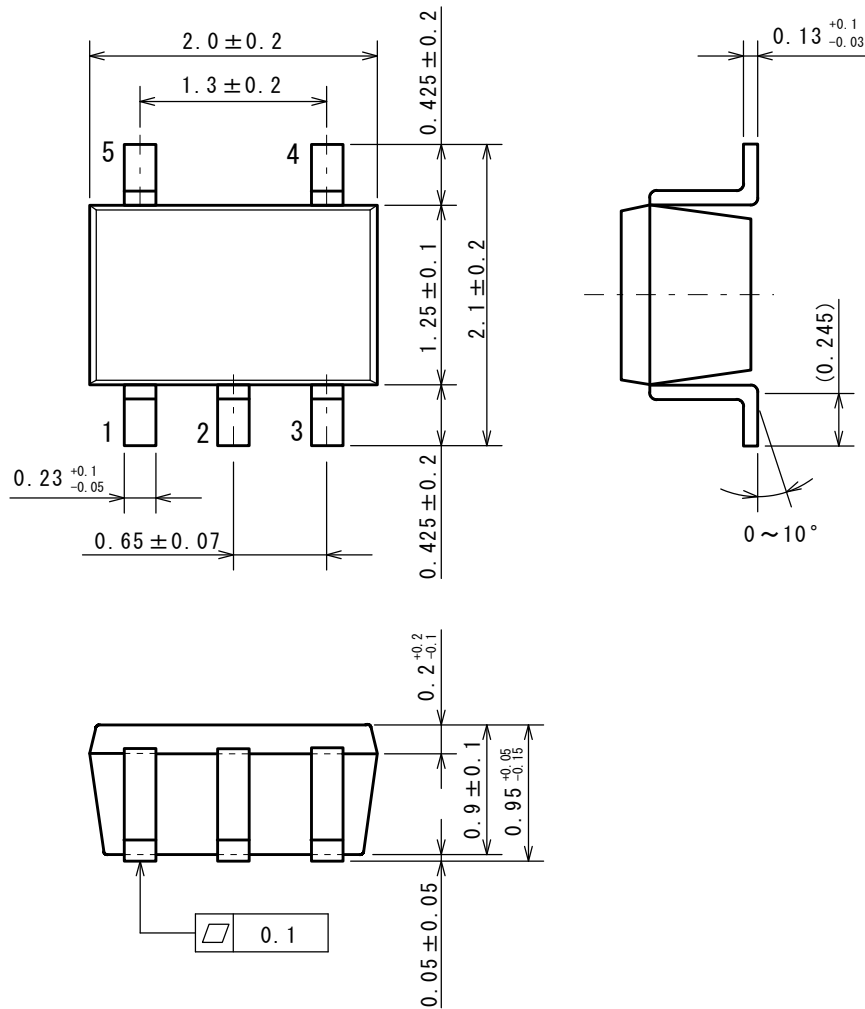

■ EXAMPLE OF SOLDER PADS DIMENSIONS

UNIT: mm

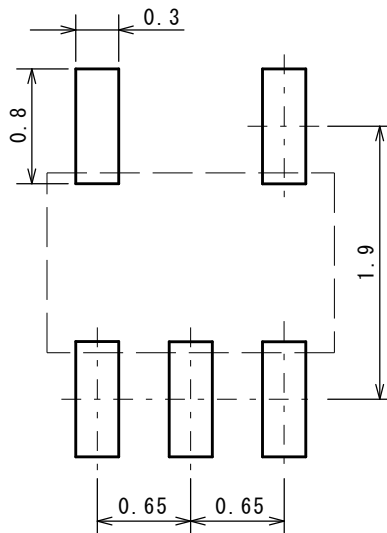

Nisshinbo Micro Devices Inc.

SC-88A

PI-SC-88A-E-A

■ PACKING SPEC

UNIT: mm

TAPING DIMENSIONS

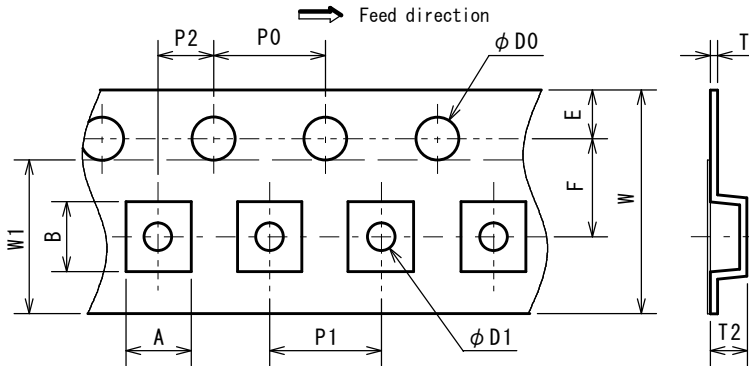

SYMBOL	DIMENSION	REMARKS
A	2.3±0.1	BOTTOM DIMENSION
B	2.5±0.1	BOTTOM DIMENSION
D0	1.55±0.05	
D1	1.05±0.05	
E	1.75±0.1	
F	3.5±0.05	
P0	4.0±0.1	
P1	4.0±0.1	
P2	2.0±0.05	
T	0.25±0.05	
T2	1.3±0.1	
W	8.0±0.2	
W1	5.5	THICKNESS 0.1max

REEL DIMENSIONS

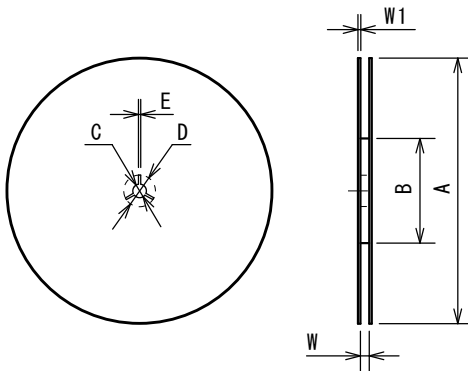

SYMBOL	DIMENSION
A	φ 180±1
B	φ 60±1
C	φ 13±0.2
D	φ 21±0.8
E	2±0.5
W	9±0.5
W1	1.2±0.2

TAPING STATE

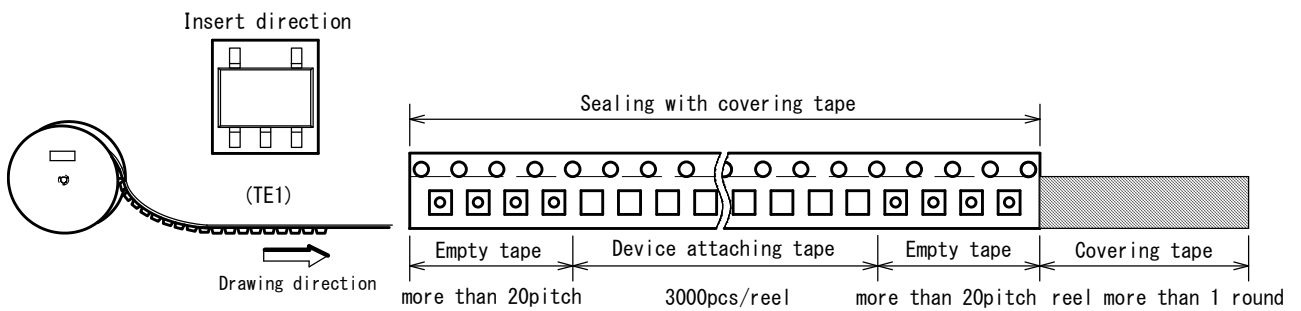

PACKING STATE

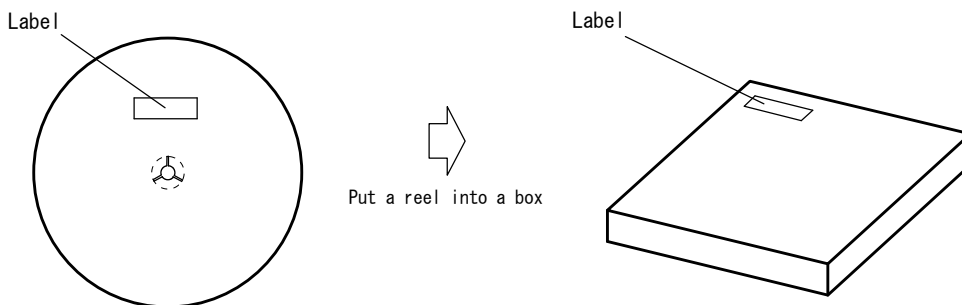

Nisshinbo Micro Devices Inc.

DFN6-G1 (ESON6-G1)

PI-DFN6-G1-E-A

■ PACKAGE DIMENSIONS

UNIT: mm

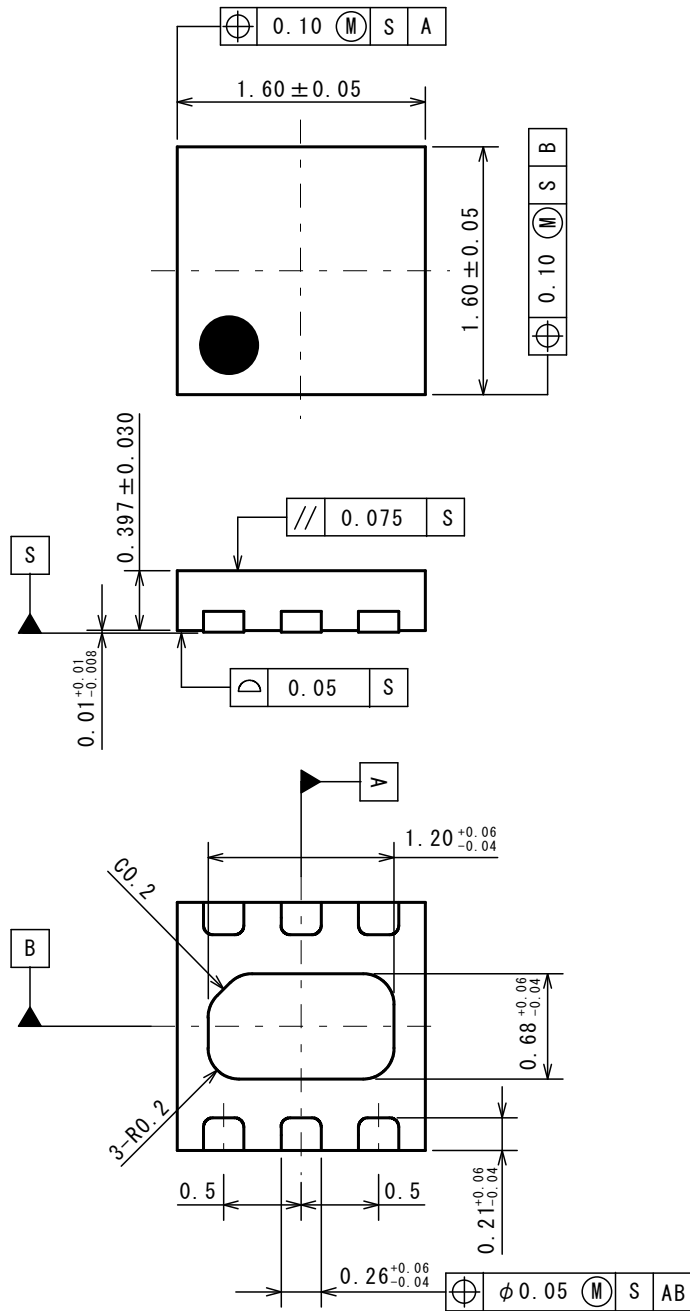

Nisshinbo Micro Devices Inc.

DFN6-G1 (ESON6-G1)

PI-DFN6-G1-E-A

■ EXAMPLE OF SOLDER PADS DIMENSIONS

UNIT: mm

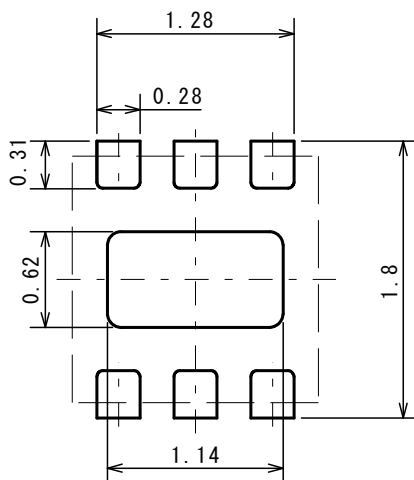

Nisshinbo Micro Devices Inc.

DFN6-G1 (ESON6-G1)

PI-DFN6-G1-E-A

■ PACKING SPEC

UNIT: mm

TAPING DIMENSIONS

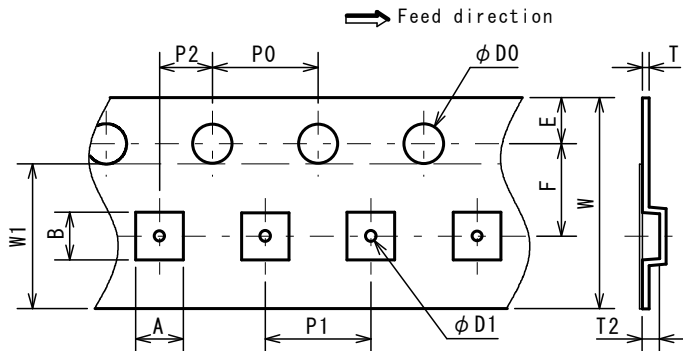

SYMBOL	DIMENSION	REMARKS
A	1.85±0.05	BOTTOM DIMENSION
B	1.85±0.05	BOTTOM DIMENSION
D0	1.5 ^{+0.1} ₀	
D1	0.5±0.1	
E	1.75±0.1	
F	3.5±0.05	
P0	4.0±0.1	
P1	4.0±0.1	
P2	2.0±0.05	
T	0.25±0.05	
T2	0.65±0.05	
W	8.0±0.2	
W1	5.5	THICKNESS 0.1max

REEL DIMENSIONS

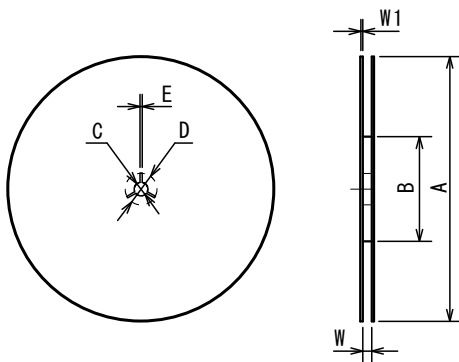

SYMBOL	DIMENSION
A	φ 180 ⁰ _{-1.5}
B	φ 60 ⁺¹ ₀
C	φ 13±0.2
D	φ 21±0.8
E	2±0.5
W	9 ^{+0.3} ₀
W1	1.2

TAPING STATE

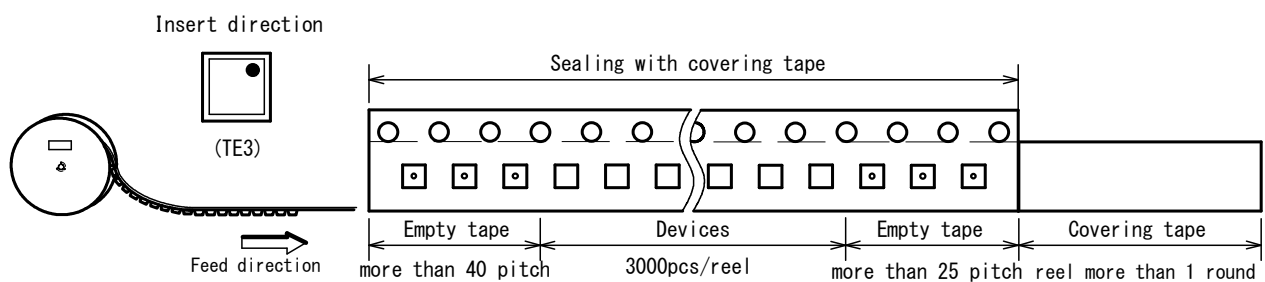

PACKING STATE

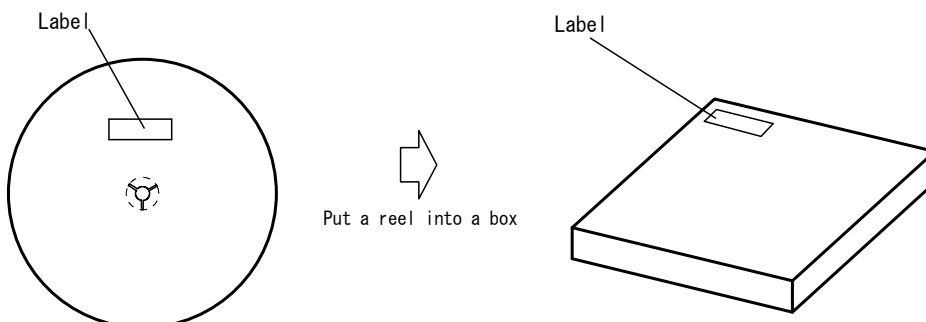

Nisshinbo Micro Devices Inc.

MSOP8 MEET JEDEC MO-187-DA (VSP8)

PI-MSOP8-E-A

■ PACKAGE DIMENSIONS

UNIT: mm

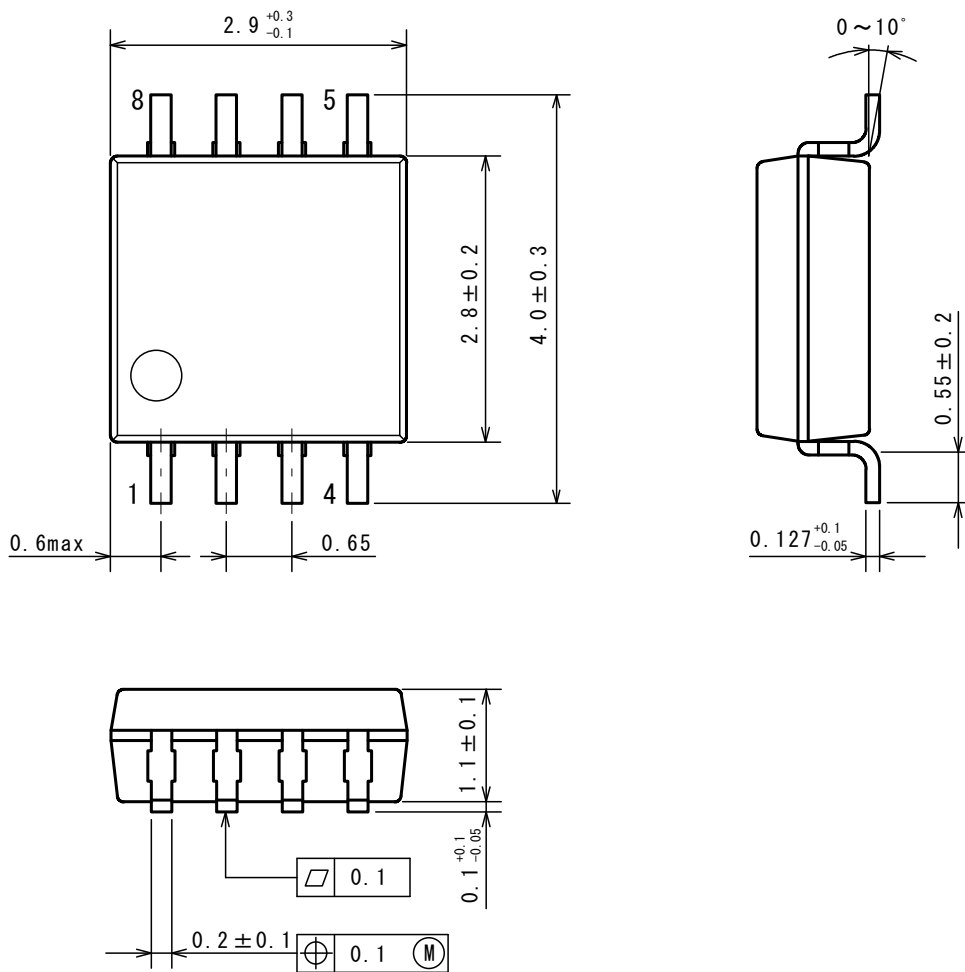

Nisshinbo Micro Devices Inc.

MSOP8 MEET JEDEC MO-187-DA (VSP8)

PI-MSOP8-E-A

■ EXAMPLE OF SOLDER PADS DIMENSIONS

UNIT: mm

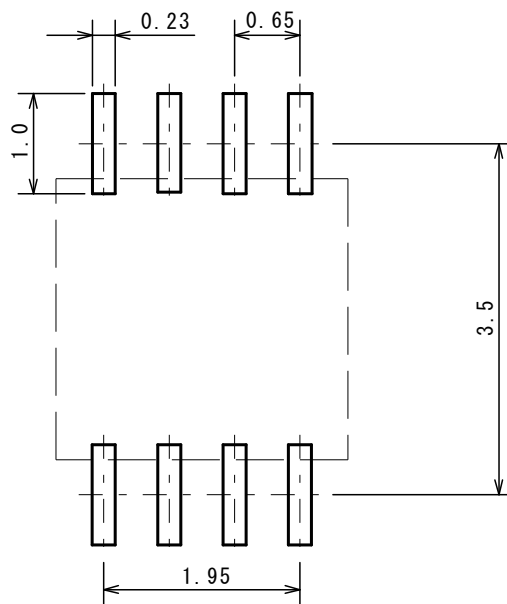

Nisshinbo Micro Devices Inc.

MSOP8 MEET JEDEC MO-187-DA (VSP8)

PI-MSOP8-E-A

PACKING SPEC

UNIT: mm

TAPING DIMENSIONS

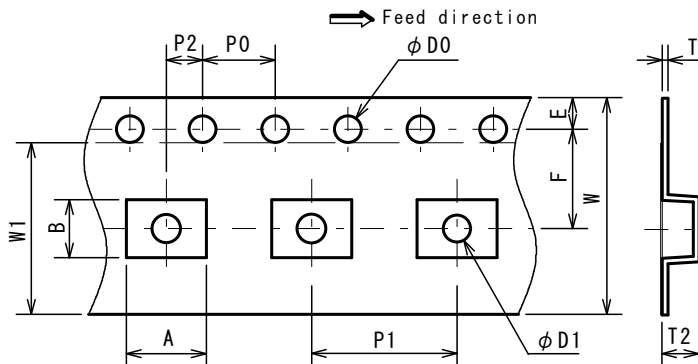

SYMBOL	DIMENSION	REMARKS
A	4.4	BOTTOM DIMENSION
B	3.2	BOTTOM DIMENSION
D0	1.5 ^{+0.1} ₀	
D1	1.5 ^{+0.1} ₀	
E	1.75±0.1	
F	5.5±0.05	
P0	4.0±0.1	
P1	8.0±0.1	
P2	2.0±0.05	
T	0.30±0.05	
T2	2.0 (MAX.)	
W	12.0±0.3	
W1	9.5	THICKNESS 0.1max

REEL DIMENSIONS

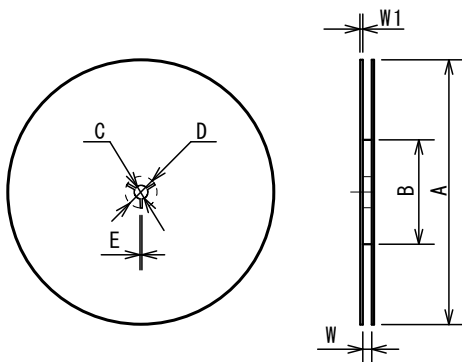

SYMBOL	DIMENSION
A	φ 254±2
B	φ 100±1
C	φ 13±0.2
D	φ 21±0.8
E	2±0.5
W	13.5±0.5
W1	2.0±0.2

TAPING STATE

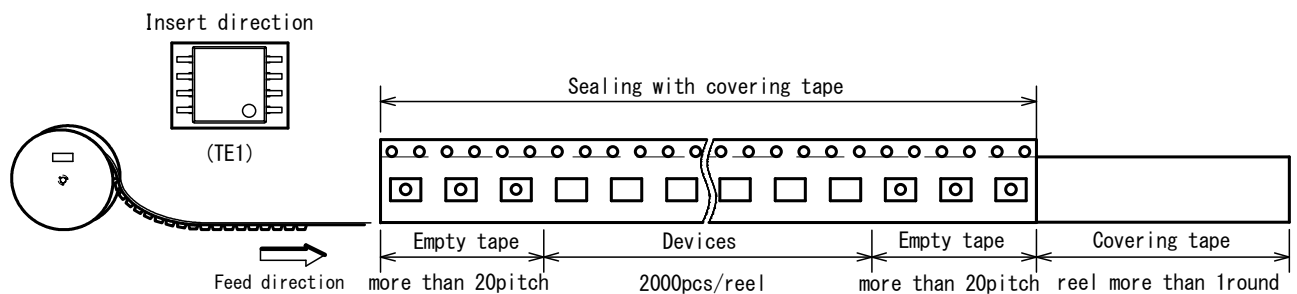

PACKING STATE

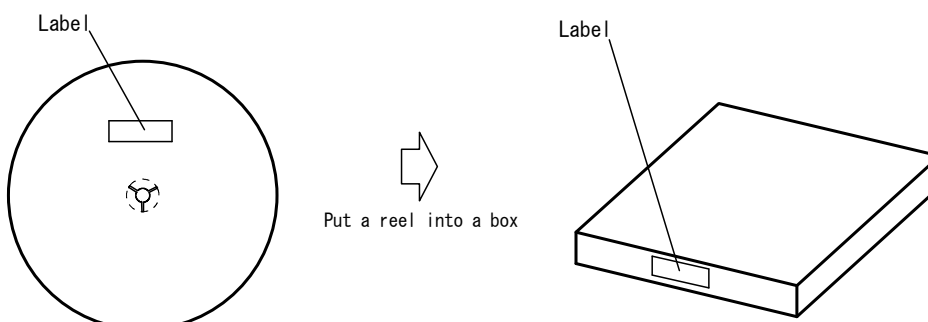

Nisshinbo Micro Devices Inc.

DFN8-U1 (ESON8-U1)

PI-DFN8-U1-E-A

■ PACKAGE DIMENSIONS

UNIT: mm

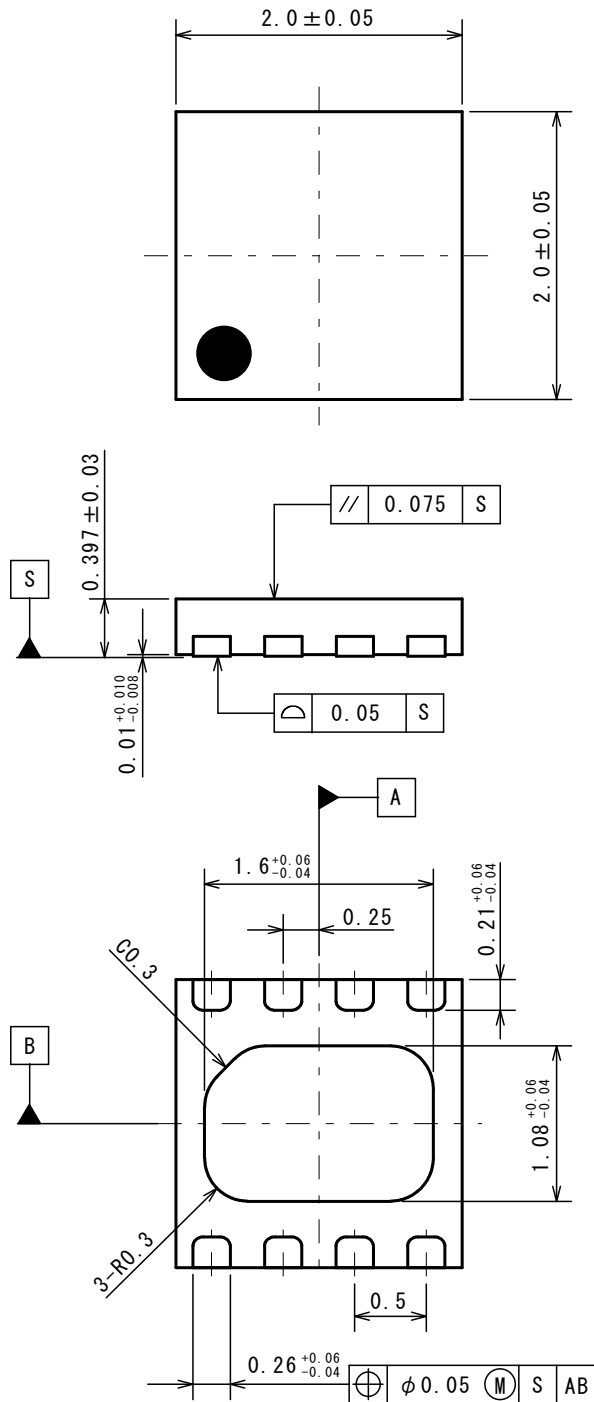

Nisshinbo Micro Devices Inc.

DFN8-U1 (ESON8-U1)

PI-DFN8-U1-E-A

■ EXAMPLE OF SOLDER PADS DIMENSIONS

UNIT: mm

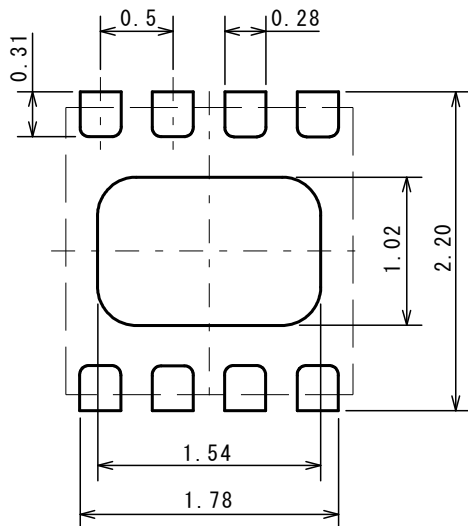

Nisshinbo Micro Devices Inc.

DFN8-U1 (ESON8-U1)

PI-DFN8-U1-E-A

PACKING SPEC

UNIT: mm

TAPING DIMENSIONS

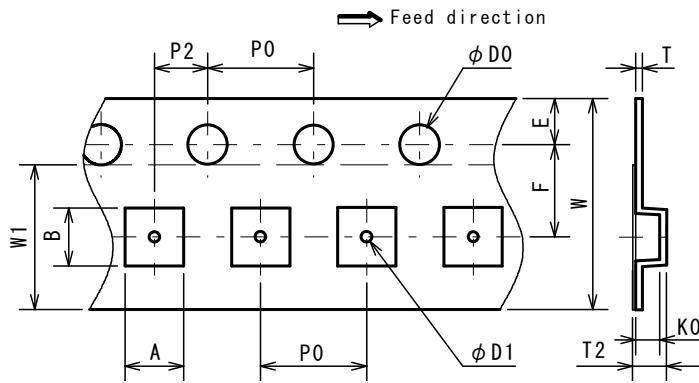

SYMBOL	DIMENSION	REMARKS
A	2.25±0.05	BOTTOM DIMENSION
B	2.25±0.05	BOTTOM DIMENSION
D0	1.5 ^{+0.1} ₀	
D1	0.5±0.1	
E	1.75±0.1	
F	3.5±0.05	
P0	4.0±0.1	
P1	4.0±0.1	
P2	2.0±0.05	
T	0.25±0.05	
T2	1.00±0.07	
K0	0.65±0.05	
W	8.0±0.2	
W1	5.5	THICKNESS 0.1max

REEL DIMENSIONS

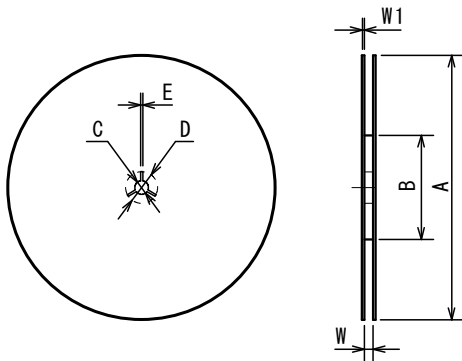

SYMBOL	DIMENSION
A	φ 180 ⁰ _{-1.5}
B	φ 60 ⁺¹ ₀
C	φ 13±0.2
D	φ 21±0.8
E	2±0.5
W	9 ^{+0.3} ₀
W1	1.2

TAPING STATE

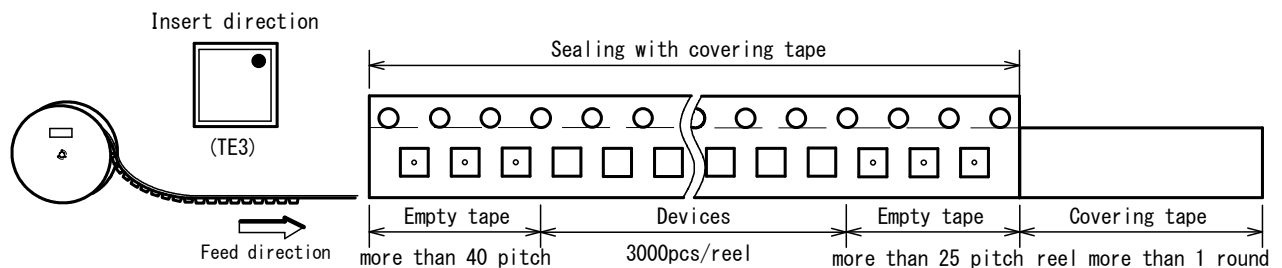

PACKING STATE

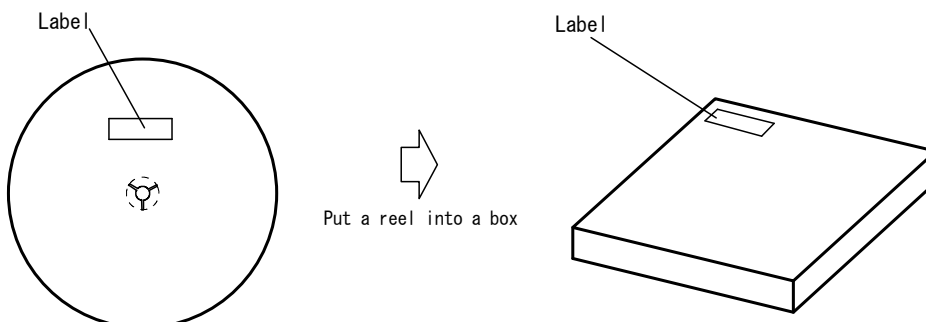

1. The products and the product specifications described in this document are subject to change or discontinuation of production without notice for reasons such as improvement. Therefore, before deciding to use the products, please refer to our sales representatives for the latest information thereon.
2. The materials in this document may not be copied or otherwise reproduced in whole or in part without the prior written consent of us.
3. This product and any technical information relating thereto are subject to complementary export controls (so-called KNOW controls) under the Foreign Exchange and Foreign Trade Law, and related politics ministerial ordinance of the law. (Note that the complementary export controls are inapplicable to any application-specific products, except rockets and pilotless aircraft, that are insusceptible to design or program changes.) Accordingly, when exporting or carrying abroad this product, follow the Foreign Exchange and Foreign Trade Control Law and its related regulations with respect to the complementary export controls.
4. The technical information described in this document shows typical characteristics and example application circuits for the products. The release of such information is not to be construed as a warranty of or a grant of license under our or any third party's intellectual property rights or any other rights.
5. The products listed in this document are intended and designed for use as general electronic components in standard applications (office equipment, telecommunication equipment, measuring instruments, consumer electronic products, amusement equipment etc.). Those customers intending to use a product in an application requiring extreme quality and reliability, for example, in a highly specific application where the failure or misoperation of the product could result in human injury or death should first contact us.
 - Aerospace Equipment
 - Equipment Used in the Deep Sea
 - Power Generator Control Equipment (nuclear, steam, hydraulic, etc.)
 - Life Maintenance Medical Equipment
 - Fire Alarms / Intruder Detectors
 - Vehicle Control Equipment (automotive, airplane, railroad, ship, etc.)
 - Various Safety Devices
 - Traffic control system
 - Combustion equipment

In case your company desires to use this product for any applications other than general electronic equipment mentioned above, make sure to contact our company in advance. Note that the important requirements mentioned in this section are not applicable to cases where operation requirements such as application conditions are confirmed by our company in writing after consultation with your company.

6. We are making our continuous effort to improve the quality and reliability of our products, but semiconductor products are likely to fail with certain probability. In order to prevent any injury to persons or damages to property resulting from such failure, customers should be careful enough to incorporate safety measures in their design, such as redundancy feature, fire containment feature and fail-safe feature. We do not assume any liability or responsibility for any loss or damage arising from misuse or inappropriate use of the products.
7. The products have been designed and tested to function within controlled environmental conditions. Do not use products under conditions that deviate from methods or applications specified in this datasheet. Failure to employ the products in the proper applications can lead to deterioration, destruction or failure of the products. We shall not be responsible for any bodily injury, fires or accident, property damage or any consequential damages resulting from misuse or misapplication of the products.
8. **Quality Warranty**
 - 8-1. **Quality Warranty Period**

In the case of a product purchased through an authorized distributor or directly from us, the warranty period for this product shall be one (1) year after delivery to your company. For defective products that occurred during this period, we will take the quality warranty measures described in section 8-2. However, if there is an agreement on the warranty period in the basic transaction agreement, quality assurance agreement, delivery specifications, etc., it shall be followed.
 - 8-2. **Quality Warranty Remedies**

When it has been proved defective due to manufacturing factors as a result of defect analysis by us, we will either deliver a substitute for the defective product or refund the purchase price of the defective product.

Note that such delivery or refund is sole and exclusive remedies to your company for the defective product.
 - 8-3. **Remedies after Quality Warranty Period**

With respect to any defect of this product found after the quality warranty period, the defect will be analyzed by us. On the basis of the defect analysis results, the scope and amounts of damage shall be determined by mutual agreement of both parties. Then we will deal with upper limit in Section 8-2. This provision is not intended to limit any legal rights of your company.
9. Anti-radiation design is not implemented in the products described in this document.
10. The X-ray exposure can influence functions and characteristics of the products. Confirm the product functions and characteristics in the evaluation stage.
11. WLCSP products should be used in light shielded environments. The light exposure can influence functions and characteristics of the products under operation or storage.
12. Warning for handling Gallium and Arsenic (GaAs) products (Applying to GaAs MMIC, Photo Reflector). These products use Gallium (Ga) and Arsenic (As) which are specified as poisonous chemicals by law. For the prevention of a hazard, do not burn, destroy, or process chemically to make them as gas or power. When the product is disposed of, please follow the related regulation and do not mix this with general industrial waste or household waste.
13. Please contact our sales representatives should you have any questions or comments concerning the products or the technical information.



Nisshinbo Micro Devices Inc.

Official website

<https://www.nisshinbo-microdevices.co.jp/en/>

Purchase information

<https://www.nisshinbo-microdevices.co.jp/en/buy/>