

NOTES:

1. MATERIALS AND FINISHES:
 BODY, CLAMP NUT, SHELL & HALF WASHER - BRASS, NICKEL PLATING
 CONTACT - BRASS, GOLD PLATING
 OUTER CONTACT - PHOSPHOR BRONZE, NICKEL PLATING
 FERRULE - COPPER, NICKEL PLATING
 SPRING WASHER - BeCu, NICKEL PLATING
 BOOT - SILICONE RUBBER
 GASKET - SILICONE RUBBER, RED
 INSULATORS - PTFE, NATURAL
2. MECHANICAL:
 A. DURABILITY: 500 CYCLES MIN.
 B. TEMPERATURE RANGE: -65° C TO +165° C
3. PACKAGING:
 A. QUANTITY: SINGLE PACK
 B. MARKING: BAG TO BE MARKED
 "AMPHENOL RF, 31-350 AND DATE CODE"
4. CABLE ASSEMBLY INSTRUCTIONS:
 A. REFER TO AMPHENOL DRAWNG. 123-219 FOR
 CABLE TO CONNECTOR ASSEMBLY INSTRUCTIONS AND
 FOR SELECTION OF PROPER BRAID CRIMPING TOOL.

5. SHOWS CABLE ENTRY DIMENSIONS.

THIRD ANGLE PROJ.

REVISIONS

REV	DESCRIPTION	DATE	ECO	APPR
--	RELEASE TO MFG	--	--	--
Y	REDRAWN IN PRO-E & COD SHEET ADDED	6/18/15	50333	NR

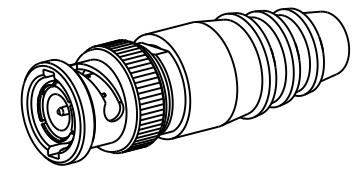

SCALE 1.000

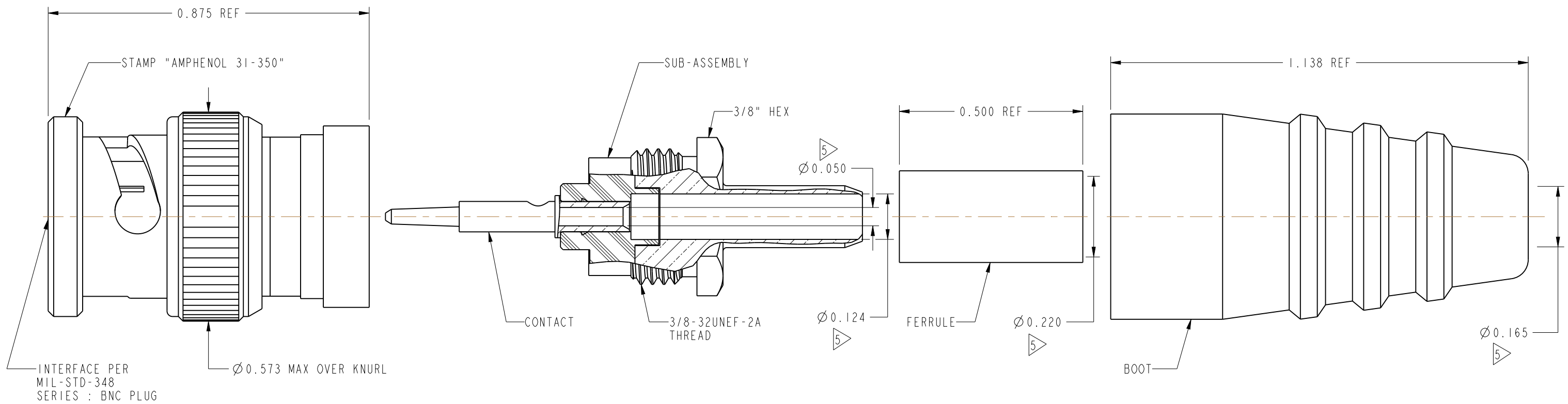

CUSTOMER OUTLINE DRAWING
 ALL OTHER SHEETS ARE FOR INTERNAL USE ONLY

UNLESS OTHERWISE SPECIFIED, DIMENSIONS ARE IN INCHES AND TOLERANCES ARE: 2 PLACE DECIMAL 3 PLACE DECIMAL ANGLES ± 0.015 (0,381 mm) ± 0.005 (0,127 mm) $\pm 1^\circ$	MATERIAL	DRAWN	DATE	TITLE QUICK CRIMP BNC STR PLUG FOR RG-55/U, 55 B/U, 142/U, 223/U CABLES		Amphenol RF www.amphenolrf.com	
	SEE NOTES	RAJAGOPAL N	02-Jan-15				
NOTICE - These drawings, specifications, or other data (1) are, and remain the property of Amphenol corp. (2) must be returned upon request; and (3) are confidential and not to be disclosed to any person other than those to whom they are given by Amphenol Corp. the furnishing of these drawings, specifications, or other data by Amphenol Corp., or to any other person to anyone for any purpose is not to be regarded by implication or otherwise in any manner licensing, granting rights to permitting such holder or any other person to manufacture, use or sell any product, process or design, patented or otherwise, that may in any way be related to or disclosed by said drawings, specifications, or other data.	REFERENCE EAR #	APPROVED	DATE	SCALE: 3.7:1.0		SHEET 2 OF 2	
	CONFIGURATION LEVEL: In Work	K. CAPOZZI	6/18/15	DWG SIZE		REV	
	FINISH	CAD FILE			B		Y
						DRAWING NO. 31-350	
						ITEM NO. 31-350	
						PART NO. 31-350	