

ISP817, ISP827, ISP847



DESCRIPTION

The ISP817, ISP827 and ISP847 series of optically coupled isolator consist of an infrared light emitting diode and an NPN silicon photo transistor in a space efficient Dual In Line Plastic Package.

FEATURES

- AC Isolation Voltage 5300V_{RMS}
- CTR Selections Available
- Wide Operating Temperature Range
-55°C to +110°C ISP817
-30°C to +100°C ISP827 / ISP847
- Lead Free and RoHS Compliant
- UL File E91231 Package Code "EE"
- VDE Approval Certificate No. 40028086

APPLICATIONS

- Computer Terminals
- Industrial System Controllers
- Measuring Instruments
- Signal Transmission between Systems of Different Potentials and Impedances

ORDER INFORMATION

- Add X after PN for VDE Approval
- Add G after PN for 10mm lead spacing
- Add SM after PN for Surface Mount
- Add SMT&R after PN for Surface Mount Tape & Reel
(Available for ISP817SM and ISP827SM)
- Consult Factory for Tape and Reel version of ISP847SM

ISP817

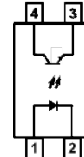

ISP827

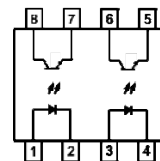

ISP847

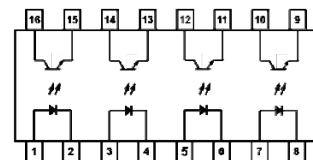

ABSOLUTE MAXIMUM RATINGS (T_A = 25°C)

Stresses exceeding the absolute maximum ratings can cause permanent damage to the device. Exposure to absolute maximum ratings for long periods of time can adversely affect reliability.

Input

| | |
|------------------------------|------|
| Forward Current | 50mA |
| Peak Forward Current | 1A |
| Pulse 100µs, Frequency 100Hz | |
| Reverse Voltage | 6V |
| Power dissipation | 70mW |

Output

| | | |
|---|-----------------|-------|
| Collector to Emitter Voltage V _{CEO} | ISP817 | 80V |
| | ISP827 / ISP847 | 35V |
| Emitter to Collector Voltage V _{ECO} | | 6V |
| Collector Current | | 50mA |
| Power Dissipation | | 150mW |

Total Package

| | | |
|----------------------------------|-----------------|----------------------|
| Isolation Voltage | | 5300V _{RMS} |
| Total Power Dissipation | | 200mW |
| Operating Temperature | ISP817 | -55 to 110 °C |
| | ISP827 / ISP847 | -30 to 100 °C |
| Storage Temperature | | -55 to 125 °C |
| Lead Soldering Temperature (10s) | | 260°C |

ISOCOM COMPONENTS 2004 LTD

Unit 25B, Park View Road West, Park View Industrial Estate
Hartlepool, Cleveland, TS25 1PE, United Kingdom
Tel : +44 (0)1429 863 609 Fax : +44 (0)1429 863 581
e-mail : sales@isocom.co.uk
<http://www.isocom.com>

ISOCOM COMPONENTS ASIA LTD

Hong Kong Office
Block A, 8/F, Wah Hing Industrial Mansion
36 Tai Yau Street, San Po Kong, Kowloon, Hong Kong
Tel : +852 2995 9217 Fax : +852 8161 6292
e-mail : sales@isocom.com.hk

ISP817, ISP827, ISP847

ELECTRICAL CHARACTERISTICS (Ambient Temperature = 25°C unless otherwise specified)

INPUT

| Parameter | Symbol | Test Condition | Min | Typ. | Max | Unit |
|----------------------|--------|----------------------------------|-----|------|-----|---------------|
| Forward Voltage | V_F | $I_F = 20\text{mA}$ | | 1.2 | 1.4 | V |
| Reverse Leakage | I_R | $V_R = 4\text{V}$ | | | 10 | μA |
| Terminal Capacitance | C_t | $V = 0\text{V}, f = 1\text{KHz}$ | | 30 | 250 | pF |

OUTPUT

| Parameter | Symbol | Test Condition | Min | Typ. | Max | Unit |
|-------------------------------------|------------|---|-----|------|-----|------|
| Collector–Emitter Breakdown Voltage | BV_{CEO} | $I_C = 0.1\text{mA}, I_F = 0\text{mA}$ | | | | V |
| | | ISP817 | 80 | | | |
| | | ISP827 / ISP847 | 35 | | | |
| Emitter–Collector Breakdown Voltage | BV_{ECO} | $I_E = 10\mu\text{A}, I_F = 0\text{mA}$ | 6 | | | V |
| Collector–Emitter Dark Current | I_{CEO} | $V_{CE} = 20\text{V}, I_F = 0\text{mA}$ | | | 100 | nA |



ISP817, ISP827, ISP847

ELECTRICAL CHARACTERISTICS (Ambient Temperature = 25°C unless otherwise specified)

COUPLED

| Parameter | Symbol | Test Condition | Min | Typ. | Max | Unit |
|--------------------------------------|---------------|--|-----|------|-----|---------------|
| Current Transfer Ratio | CTR | $I_F = 5\text{mA}, V_{CE} = 5\text{V}$ | 50 | | 600 | % |
| | | Optional CTR Grades | | | | |
| | | GB | 100 | | 600 | |
| | | BL | 200 | | 600 | |
| | | A | 80 | | 160 | |
| | | B | 130 | | 260 | |
| | | C | 200 | | 400 | |
| D | 300 | | 600 | | | |
| Collector–Emitter Saturation Voltage | $V_{CE(sat)}$ | $I_F = 20\text{mA}, I_C = 1\text{mA}$ | | 0.1 | 0.2 | V |
| Floating Capacitance | C_f | $V = 0\text{V}, f = 1\text{MHz}$ | | 0.6 | 1 | pF |
| Cut-Off Frequency | f_c | $V_{CE} = 5\text{V}, I_C = 2\text{mA}, R_L = 100\Omega, -3\text{dB}$ | | 80 | | kHz |
| Output Rise Time | t_r | $V_{CE} = 2\text{V}, I_C = 2\text{mA}, R_L = 100\Omega$ | | 4 | 18 | μs |
| Output Fall Time | t_f | | | 3 | 18 | |

ISOLATION

| Parameter | Symbol | Test Condition | Min | Typ. | Max | Unit |
|--------------------------------------|-----------|---|--------------------|--------------------|-----|-----------|
| Input to Output Isolation Voltage | V_{ISO} | AC 1 minute, RH = 40% to 60% Note 1 | 5300 | | | V_{RMS} |
| Input to Output Isolation Resistance | R_{ISO} | $V_{IO} = 500\text{V}, \text{RH} = 40\% \text{ to } 60\%$ Note 1 | 5×10^{10} | 1×10^{11} | | Ω |

Note 1 : Measure with input leads shorted together and output leads shorted together.

ISP817, ISP827, ISP847

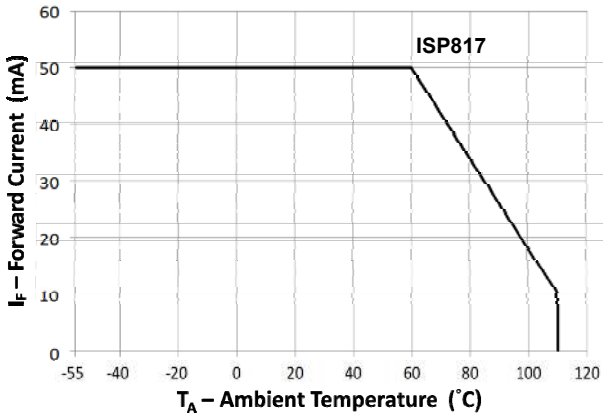

Fig 1 Forward Current vs Ambient Temperature (1)

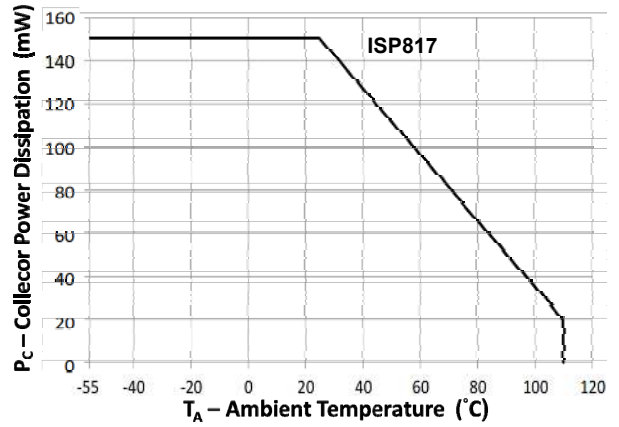

Fig 2 Collector Power Dissipation vs Ambient Temperature (1)

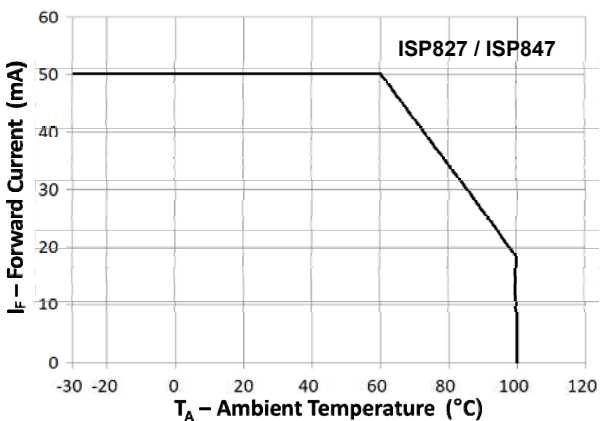

Fig 3 Forward Current vs Ambient Temperature (2)

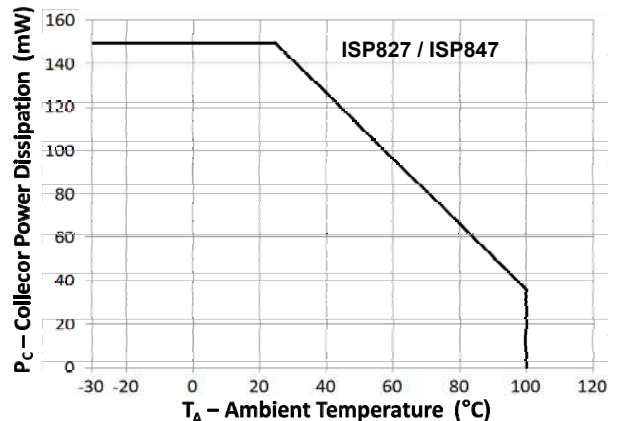

Fig 4 Collector Power Dissipation vs Ambient Temperature (2)

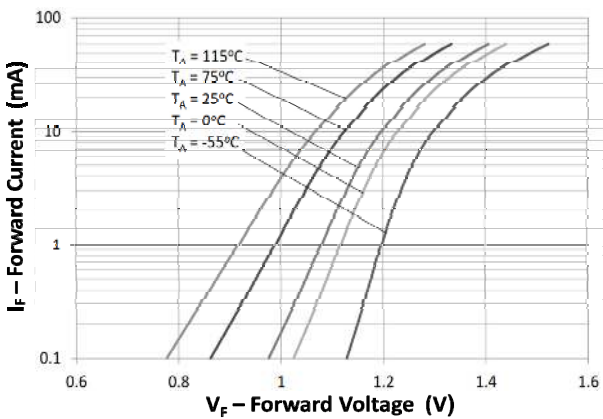

Fig 5 Forward Current vs Forward Voltage

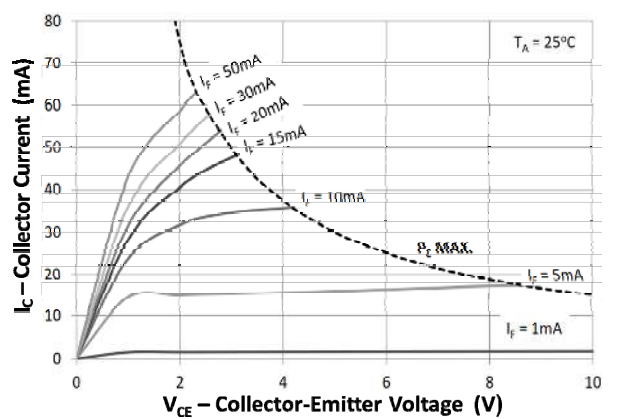

Fig 6 Collector Current vs Collector-Emitter Voltage

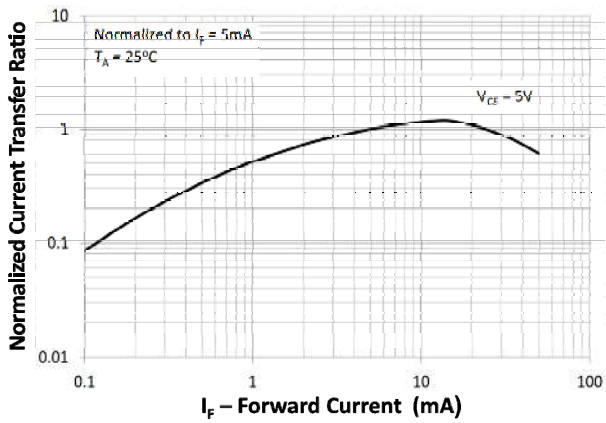

Fig 7 Normalized Current Transfer Ratio vs Forward Current

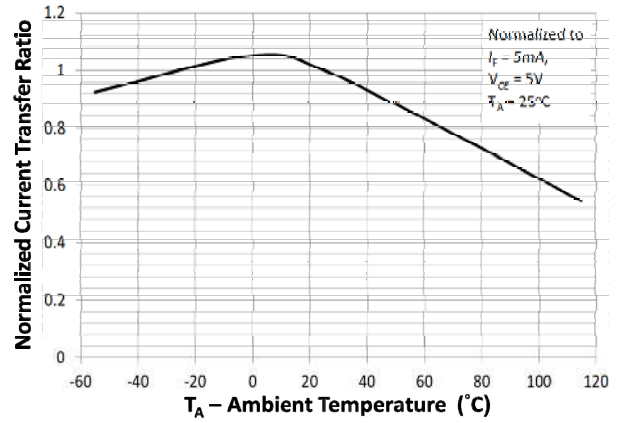

Fig 8 Normalized Current Transfer Ratio vs Ambient Temperature

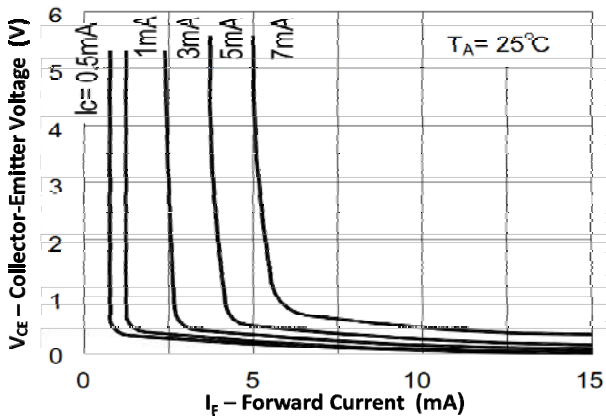

Fig 9 Collector-Emitter Voltage vs Forward Current

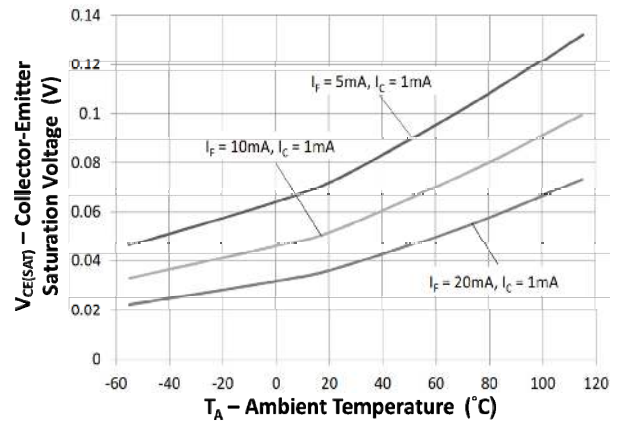

Fig 10 Collector-Emitter Saturation Voltage vs Ambient Temperature

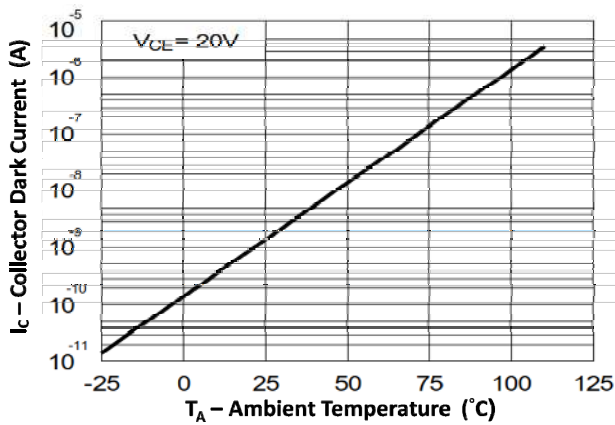

Fig 11 Collector Dark Current vs Ambient Temperature

ISP817, ISP827, ISP847

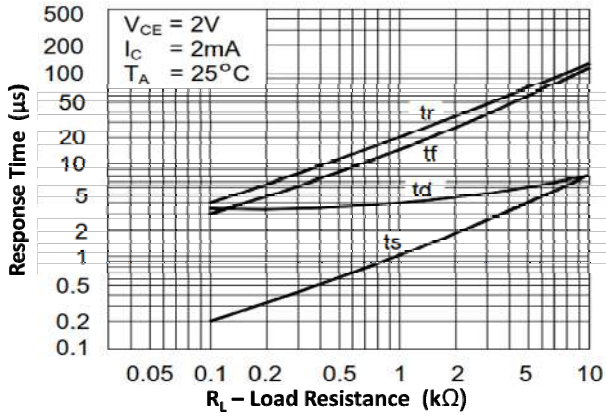
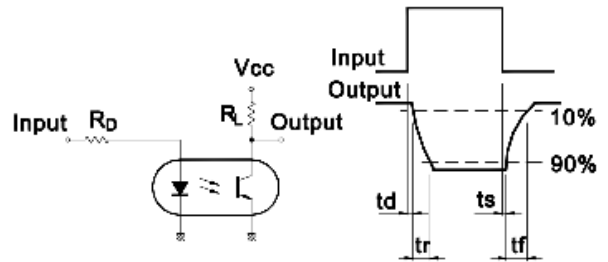

Fig 12 Response Time vs Load Resistance



Response Time Test Circuit

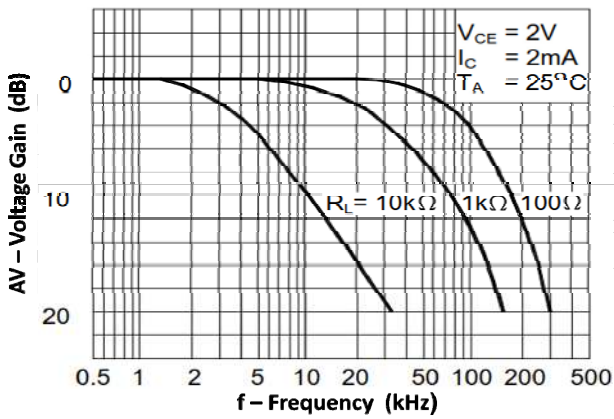
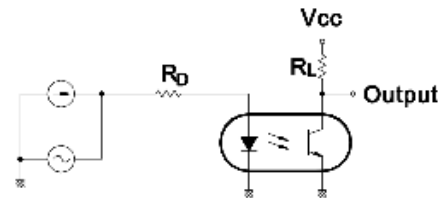

Fig 13 Frequency Response



Frequency Response Test Circuit



ISP817, ISP827, ISP847

ORDER INFORMATION

| ISP817 (UL Approval) | | | |
|-----------------------------|--|---------------------------|-------------------------|
| After PN | PN | Description | Packing quantity |
| None | ISP817, ISP817GB, ISP817BL, ISP817A, ISP817B, ISP817C, ISP817D | Standard DIP4 | 100 pcs per tube |
| G | ISP817G, ISP817GBG, ISP817BLG, ISP817AG, ISP817BG, ISP817CG, ISP817DG | 10mm Lead Spacing | 100 pcs per tube |
| SM | ISP817SM, ISP817GBSM, ISP817BLSM, ISP817ASM, ISP817BSM, ISP817CSM, ISP817DSM | Surface Mount | 100 pcs per tube |
| SMT&R | ISP817SMT&R, ISP817GBSMT&R, ISP817BLSMT&R, ISP817ASMT&R, ISP817BSMT&R, ISP817CSMT&R, ISP817DSMT&R | Surface Mount Tape & Reel | 1000 pcs per reel |

| ISP827 (UL Approval) | | | |
|-----------------------------|--|---------------------------|-------------------------|
| After PN | PN | Description | Packing quantity |
| None | ISP827, ISP827GB, ISP827BL, ISP827A, ISP827B, ISP827C, ISP827D | Standard DIP8 | 50 pcs per tube |
| G | ISP827G, ISP827GBG, ISP827BLG, ISP827AG, ISP827BG, ISP827CG, ISP827DG | 10mm Lead Spacing | 50 pcs per tube |
| SM | ISP827SM, ISP827GBSM, ISP827BLSM, ISP827ASM, ISP827BSM, ISP827CSM, ISP827DSM | Surface Mount | 50 pcs per tube |
| SMT&R | ISP827SMT&R, ISP827GBSMT&R, ISP827BLSMT&R, ISP827ASMT&R, ISP827BSMT&R, ISP827CSMT&R, ISP827DSMT&R | Surface Mount Tape & Reel | 1000 pcs per reel |

| ISP847 (UL Approval) | | | |
|-----------------------------|--|--------------------|-------------------------|
| After PN | PN | Description | Packing quantity |
| None | ISP847, ISP847GB, ISP847BL, ISP847A, ISP847B, ISP847C, ISP847D | Standard DIP16 | 25 pcs per tube |
| G | ISP847G, ISP847GBG, ISP847BLG, ISP847AG, ISP847BG, ISP847CG, ISP847DG | 10mm Lead Spacing | 25 pcs per tube |
| SM | ISP847SM, ISP847GBSM, ISP847BLSM, ISP847ASM, ISP847BSM, ISP847CSM, ISP847DSM | Surface Mount | 25 pcs per tube |



ISP817, ISP827, ISP847

ORDER INFORMATION

| ISP817X (UL and VDE Approvals) | | | |
|---------------------------------------|---|---------------------------|-------------------------|
| After PN | PN | Description | Packing quantity |
| None | ISP817X, ISP817XGB, ISP817XBL, ISP817XA, ISP817XB, ISP817XC, ISP817XD | Standard DIP4 | 100 pcs per tube |
| G | ISP817XG, ISP817XGBG, ISP817XBLG, ISP817XAG, ISP817XBG, ISP817XCG, ISP817XDG | 10mm Lead Spacing | 100 pcs per tube |
| SM | ISP817XSM, ISP817XGBSM, ISP817XBLSM, ISP817XASM, ISP817XBXSM, ISP817XCSM, ISP817XDMSM | Surface Mount | 100 pcs per tube |
| SMT&R | ISP817XSMT&R, ISP817XGBSMT&R, ISP817XBLSMT&R, ISP817XASMT&R, ISP817XBSMT&R, ISP817XCSMT&R, ISP817XDSMT&R | Surface Mount Tape & Reel | 1000 pcs per reel |

| ISP827X (UL and VDE Approvals) | | | |
|---------------------------------------|---|---------------------------|-------------------------|
| After PN | PN | Description | Packing quantity |
| None | ISP827X, ISP827XGB, ISP827XBL, ISP827XA, ISP827XB, ISP827XC, ISP827XD | Standard DIP8 | 50 pcs per tube |
| G | ISP827XG, ISP827XGBG, ISP827XBLG, ISP827XAG, ISP827XBG, ISP827XCG, ISP827XDG | 10mm Lead Spacing | 50 pcs per tube |
| SM | ISP827XSM, ISP827XGBSM, ISP827XBLSM, ISP827XASM, ISP827XBBSM, ISP827XCSM, ISP827XDMSM | Surface Mount | 50 pcs per tube |
| SMT&R | ISP827XSMT&R, ISP827XGBSMT&R, ISP827XBLSMT&R, ISP827XASMT&R, ISP827XBSMT&R, ISP827XCSMT&R, ISP827XDSMT&R | Surface Mount Tape & Reel | 1000 pcs per reel |

| ISP847 (UL and VDE Approvals) | | | |
|--------------------------------------|--|--------------------|-------------------------|
| After PN | PN | Description | Packing quantity |
| None | ISP847X, ISP847XGBL, ISP847XBL, ISP847XA, ISP847XB, ISP847XC, ISP847XD | Standard DIP16 | 25 pcs per tube |
| G | ISP847XG, ISP847XGBG, ISP847XBLG, ISP847XAG, ISP847XBG, ISP847XCG, ISP847XDG | 10mm Lead Spacing | 25 pcs per tube |
| SM | ISP847XSM, ISP847XGBSM, ISP847XBLSM, ISP847XASM, ISP847XBBSM, ISP847XCSM, ISP847XDMSM | Surface Mount | 25 pcs per tube |

ISP817, ISP827, ISP847

PACKAGE DIMENSIONS in mm (inch)

DIP

ISP817

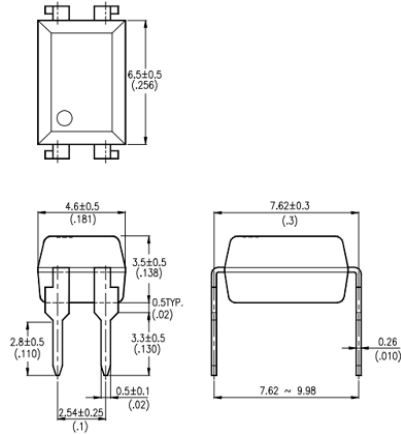

ISP827

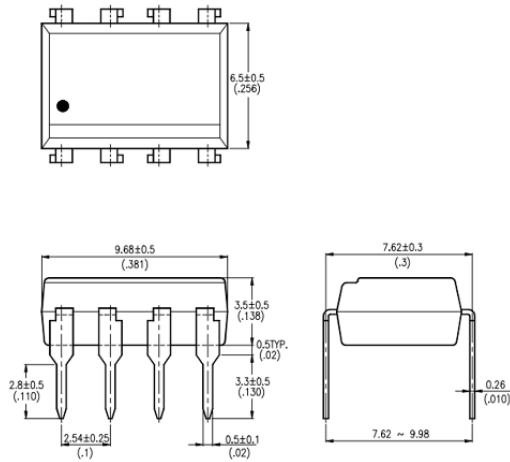

ISP847

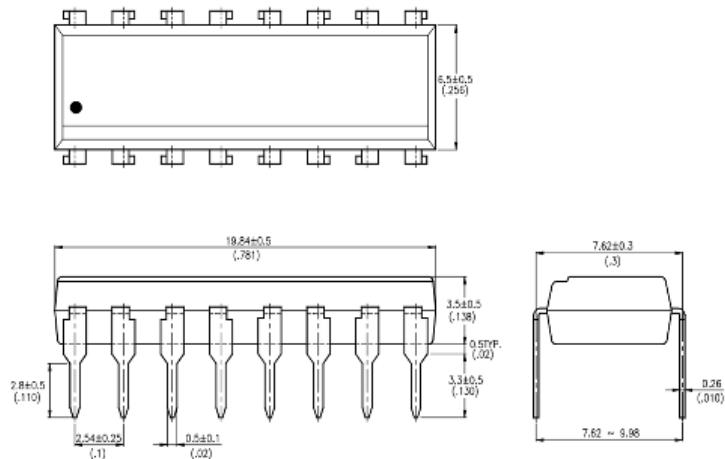

ISP817, ISP827, ISP847

PACKAGE DIMENSIONS in mm (inch)

G Form

ISP817

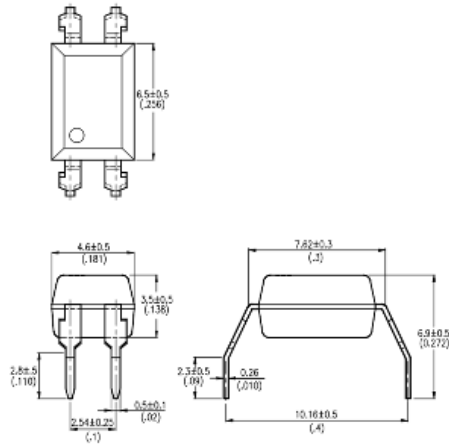

ISP827

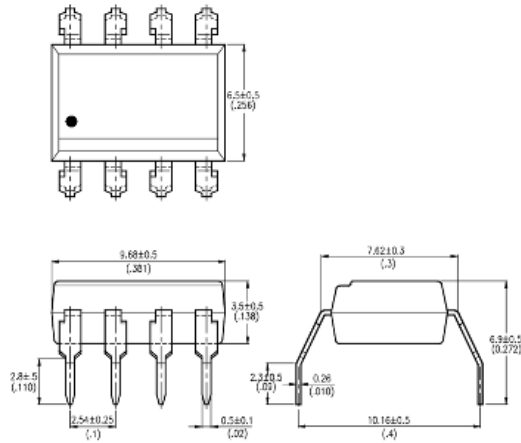

ISP847

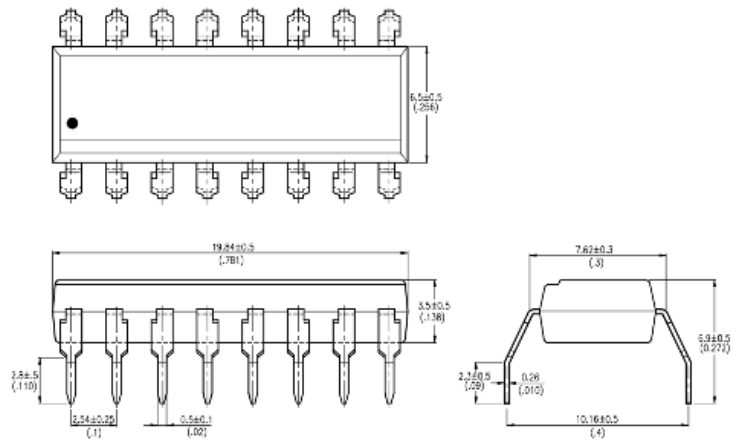

ISP817, ISP827, ISP847

PACKAGE DIMENSIONS in mm (inch)

SMD

ISP817

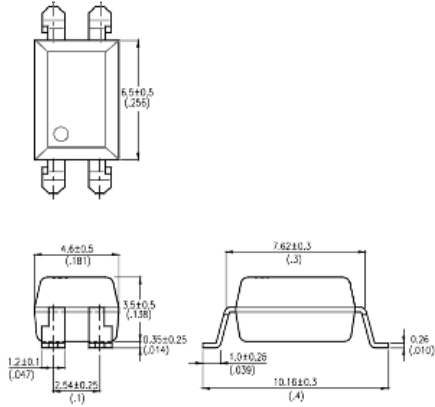

ISP827

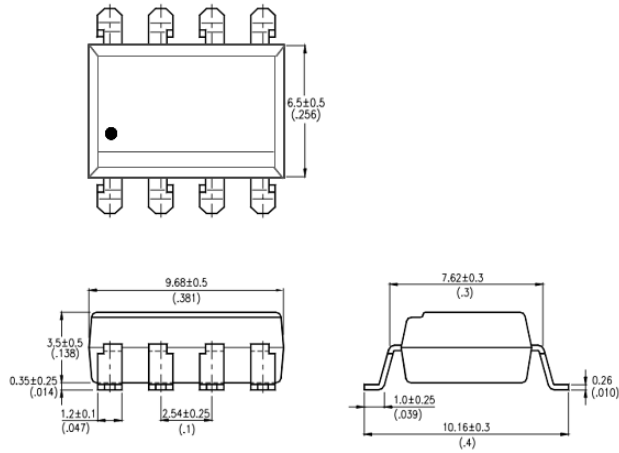

ISP847

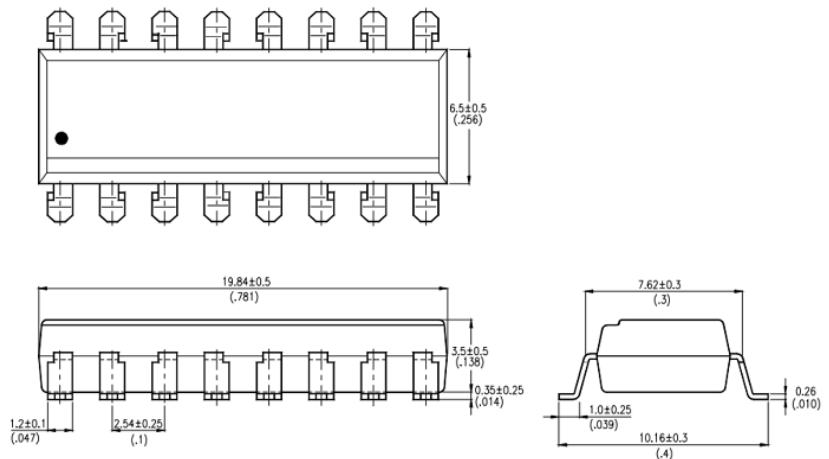

RECOMMENDED PAD LAYOUT FOR SMD (mm)

ISP817SM

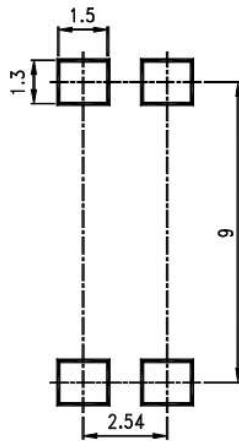

ISP827SM

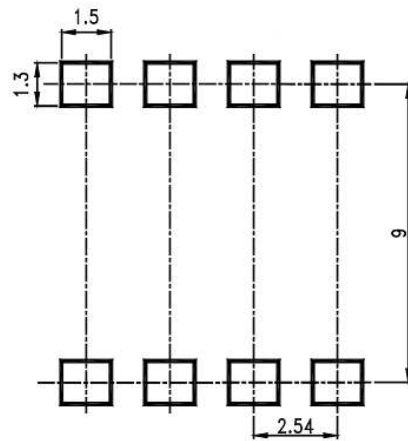

ISP847SM

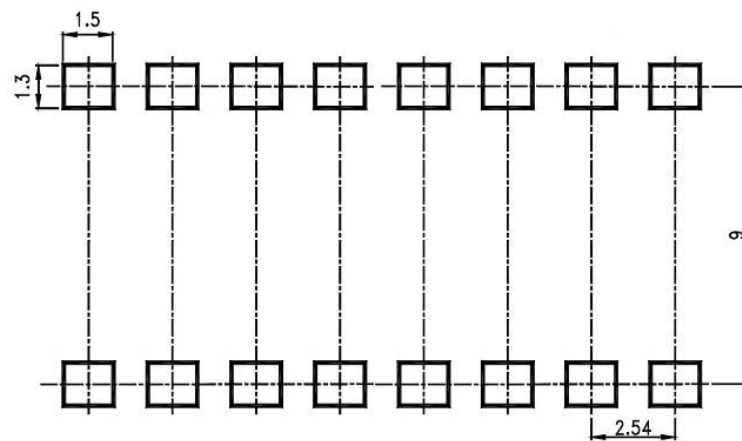

ISP817, ISP827, ISP847

TAPE AND REEL PACKAGING

ISP817SMT&R

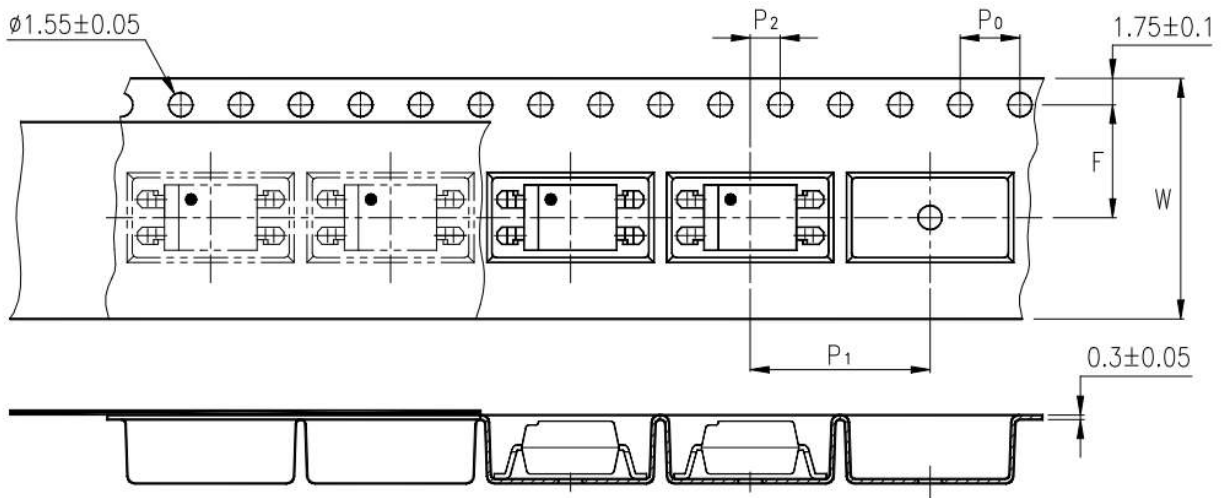

ISP827SMT&R

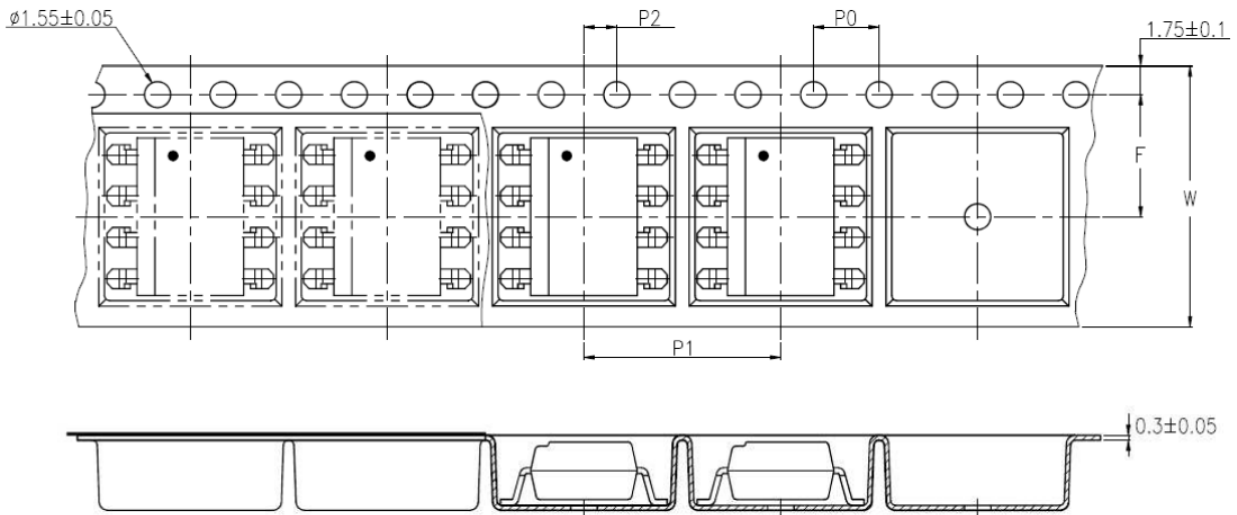

| Description | Symbol | Dimension mm (inch) |
|---|--------|------------------------|
| Tape Width | W | 16 ± 0.3 (0.63) |
| Pitch of Sprocket Holes | P_0 | 4 ± 0.1 (0.15) |
| Distance of Compartment to Sprocket Holes | F | 7.5 ± 0.1 (0.295) |
| | P_2 | 2 ± 0.1 (0.079) |
| Distance of Compartment to Compartment | P_1 | 12 ± 0.1 (0.472) |

IR REFLOW SOLDERING TEMPERATURE PROFILE FOR SMD
One Time Reflow Soldering is Recommended.
Do not immerse device body in solder paste.

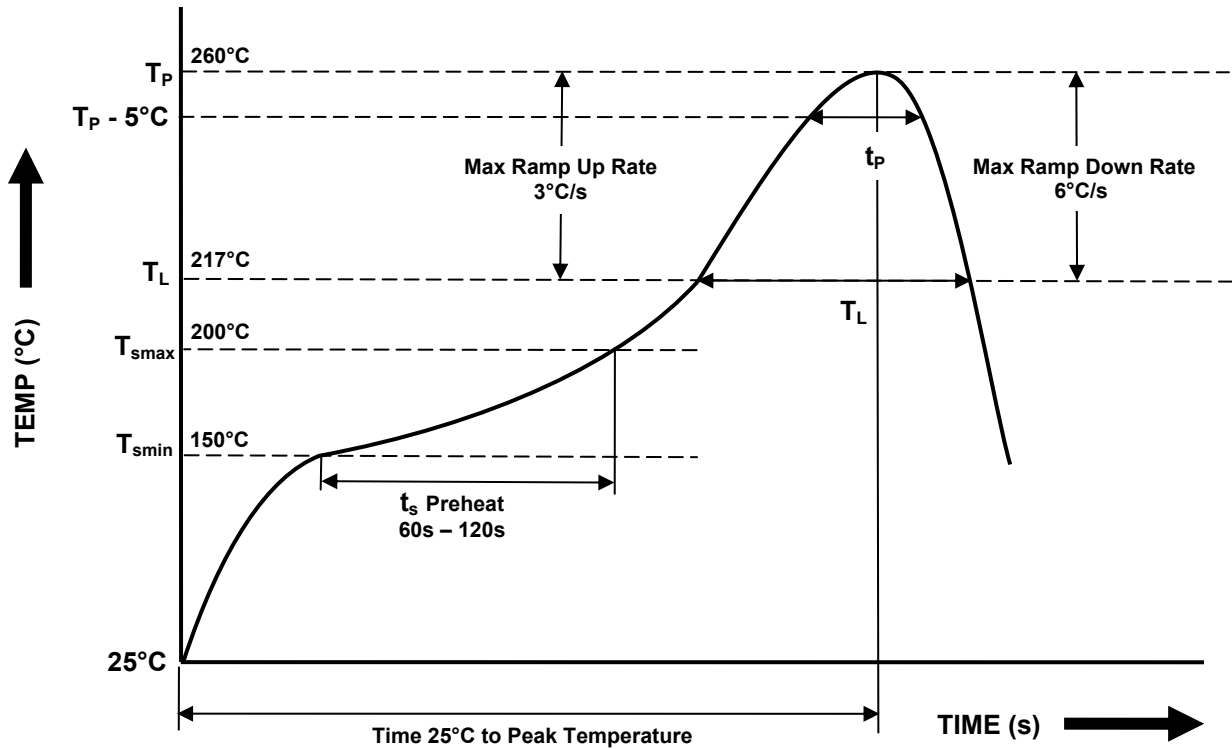

| Profile Details | Conditions |
|---|--|
| Preheat - Min Temperature (T _{SMIN}) - Max Temperature (T _{SMAX}) - Time T _{SMIN} to T _{SMAX} (t _s) | 150°C 200°C 60s - 120s |
| Soldering Zone - Peak Temperature (T _P) - Time at Peak Temperature - Liquidous Temperature (T _L) - Time within 5°C of Actual Peak Temperature (T _P - 5°C) - Time maintained above T _L (t _L) - Ramp Up Rate (T _L to T _P) - Ramp Down Rate (T _P to T _L) | 260°C 10s max 217°C 30s max 60s - 100s 3°C/s max 6°C/s max |
| Average Ramp Up Rate (T _{smax} to T _P) | 3°C/s max |
| Time 25°C to Peak Temperature | 8 minutes max |



DISCLAIMER

Isocom Components is continually working to improve the quality and reliability of its products. Nevertheless, semiconductor devices in general can malfunction or fail due to their inherent electrical sensitivity and vulnerability to physical stress. It is the responsibility of the buyer, when utilizing Isocom Components products, to comply with the standards of safety in making a safe design for the entire system, and to avoid situations in which a malfunction or failure of such Isocom Components products could cause loss of human life, bodily injury or damage to property.

In developing your designs, please ensure that Isocom Components products are used within specified operating ranges as set forth in the most recent Isocom Components products specifications.

The Isocom Components products listed in this document are intended for usage in general electronics applications (computer, personal equipment, office equipment, measuring equipment, industrial robotics, domestic appliances, etc.). These Isocom Components products are neither intended nor warranted for usage in equipment that requires extraordinarily high quality and/or reliability or a malfunction or failure of which may cause loss of human life or bodily injury ("Unintended Usage"). Unintended Usage include atomic energy control instruments, airplane or spaceship instruments, transportation Instruments, traffic signal instruments, combustion control instruments, medical Instruments, all types of safety devices, etc... Unintended Usage of Isocom Components products listed in this document shall be made at the customer's own risk.

Gallium arsenide (GaAs) is a substance used in the products described in this document. GaAs dust and fumes are toxic. Do not break, cut or pulverize the product, or use chemicals to dissolve them. When disposing of the products, follow the appropriate regulations. Do not dispose of the products with other industrial waste or with domestic garbage.

The products described in this document are subject to the foreign exchange and foreign trade laws.

The information contained herein is presented only as a guide for the applications of our products. No responsibility is assumed by Isocom Components for any infringements of intellectual property or other rights of the third parties which may result from its use. No license is granted by implication or otherwise under any intellectual property or other rights of Isocom Components or others.

The information contained herein is subject to change without notice.