



American Opto Plus LED Corp.

L314YGD

3mm Yellow Green LED Lamp

PACKAGE OUTLINES

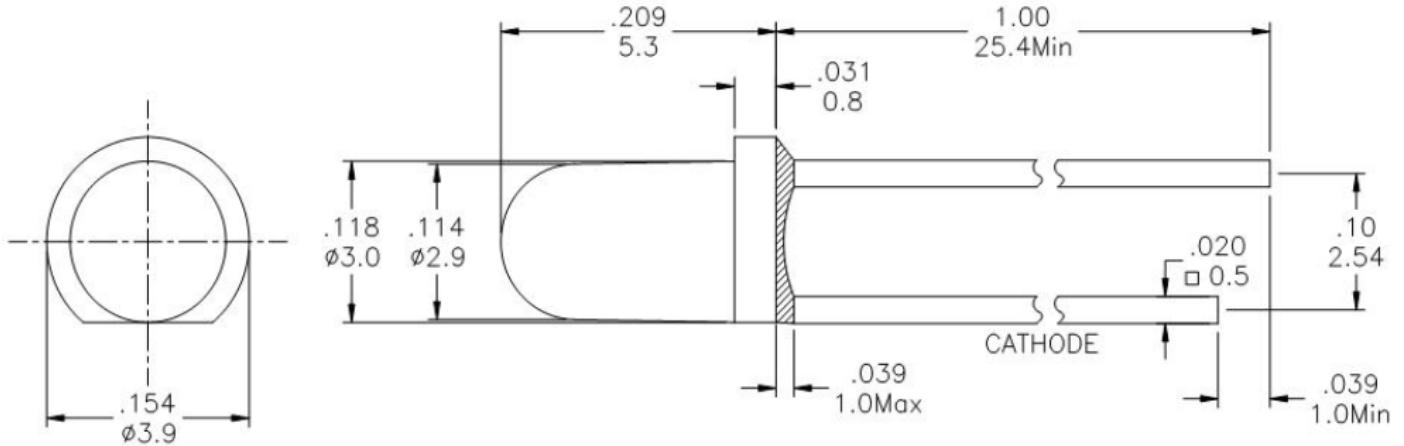

Notes:

1. All dimensions are in millimeters (inch).
2. Tolerances are $\pm 0.25\text{mm}$ (± 0.01 inch) unless otherwise noted.

Part Number	Material	Color	
		Emitted	Lens
L314YGD	AllnGaP	Yellow Green	Green Diffused



American Opto Plus LED Corp.

L314YGD

3mm Yellow Green LED Lamp

ABSOLUTE MAXIMUM RATINGS

(Ta=25°C)

Parameter	Symbol	Value	Unit
Power Dissipation	P _D	72	mW
Reverse Voltage	V _R	5	V
Forward Current	I _F	30	mA
Peak Forward Current (Duty=0.1, 1kHz)	I _{FP}	100	mA
Operating Temperature Range	T _{OPR}	-40~+80	°C
Storage Temperature Range	T _{STG}	-40~+100	°C
Lead Soldering Temperature	T _{SOL}	Max 260°C for 5 sec (1.6mm(0.063inch) from Body)	

OPTICAL-ELECTRICAL CHARACTERISTICS

(Ta=25°C)

Parameter	Symbol	Test Condition	Min	Typ	Max	Unit
Forward Voltage	V _F	I _F =10mA	--	2.0	2.4	V
Dominant Wavelength	λ _D		--	570	--	nm
Viewing Angle	2θ _{1/2}		--	50	--	deg
Luminous Intensity	I _V		9.2	25	--	mcd
		I _F =20mA	16	45	--	
Reverse Current	I _R	V _R =5V	--	--	100	μA

Notes:

1. Forward voltage data did not include ±0.1V testing tolerance.
2. Luminous intensity data did not included ±15% testing tolerance.



American Opto Plus LED Corp.

L314YGD

3mm Yellow Green LED Lamp

BIN COMBINATIONS

Luminous Intensity Rank Limits ($I_F=10\text{mA}$)

Code	Min	Max	Unit
15	9.2	16	mcd
16	16	27	
17	27	45	
18	45	77	

Dominant Wavelength Rank Limits ($I_F=10\text{mA}$)

Code	Min	Max	Unit
YG3	565	567	nm
YG4	567	569	
YG5	569	571	
YG6	571	573	

Forward Voltage Rank Limits ($I_F=10\text{mA}$)

Code	Min	Max	Unit
B	1.6	1.8	V
C	1.8	2.0	
D	2.0	2.2	
E	2.2	2.4	

Notes:

1. Luminous intensity tolerance: $\pm 15\%$
2. Dominant wavelength tolerance: $\pm 2\text{nm}$
3. Forward voltage tolerance: $\pm 0.05\text{V}$
4. One delivery will include several color rank, V_F rank & I_v rank of products. The quantity-ratio of ranks is decided by AOP.



American Opto Plus LED Corp.

L314YGD

3mm Yellow Green LED Lamp

OPTICAL CHARACTERISTIC CURVES

Fig 1. Forward Current vs. Forward Voltage

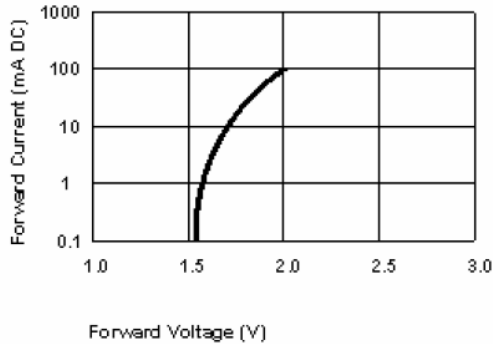

Fig 2. Relative Intensity vs. Forward Current

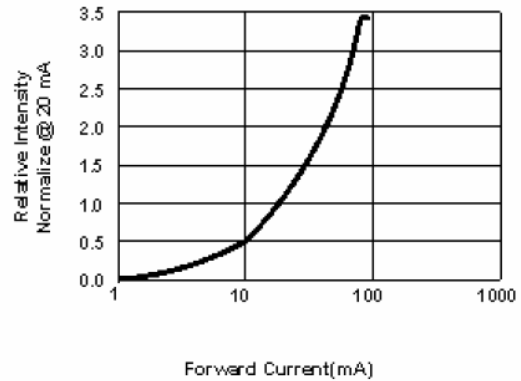

Fig 3. Forward Voltage vs. Temperature

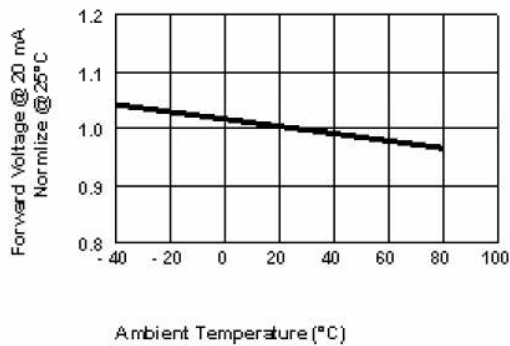

Fig 4. Relative Intensity vs. Temperature

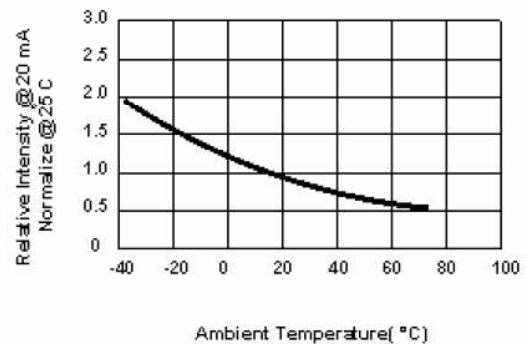

Fig 5. Relative Intensity Vs. Wavelength

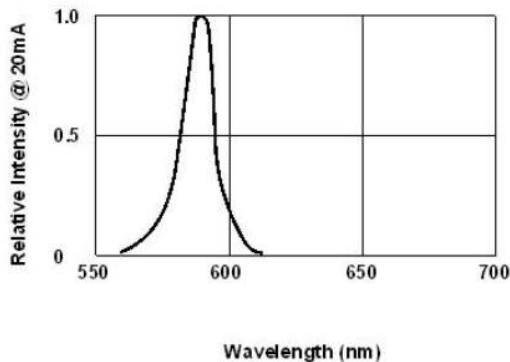
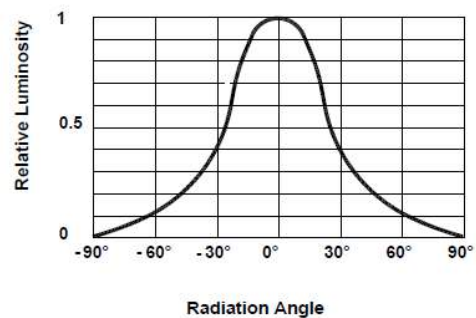

Fig6. Relative Luminous Intensity Vs. RadRadiation





American Opto Plus LED Corp.

L314YGD

3mm Yellow Green LED Lamp

PRECAUTION FOR USE

1. Recommended Soldering Condition

1.1 Wave Soldering

Basic spec is ≤ 5 sec. when 260°C . If temperature is higher, time should be shorter ($+10^{\circ}\text{C} \rightarrow -1$ sec).

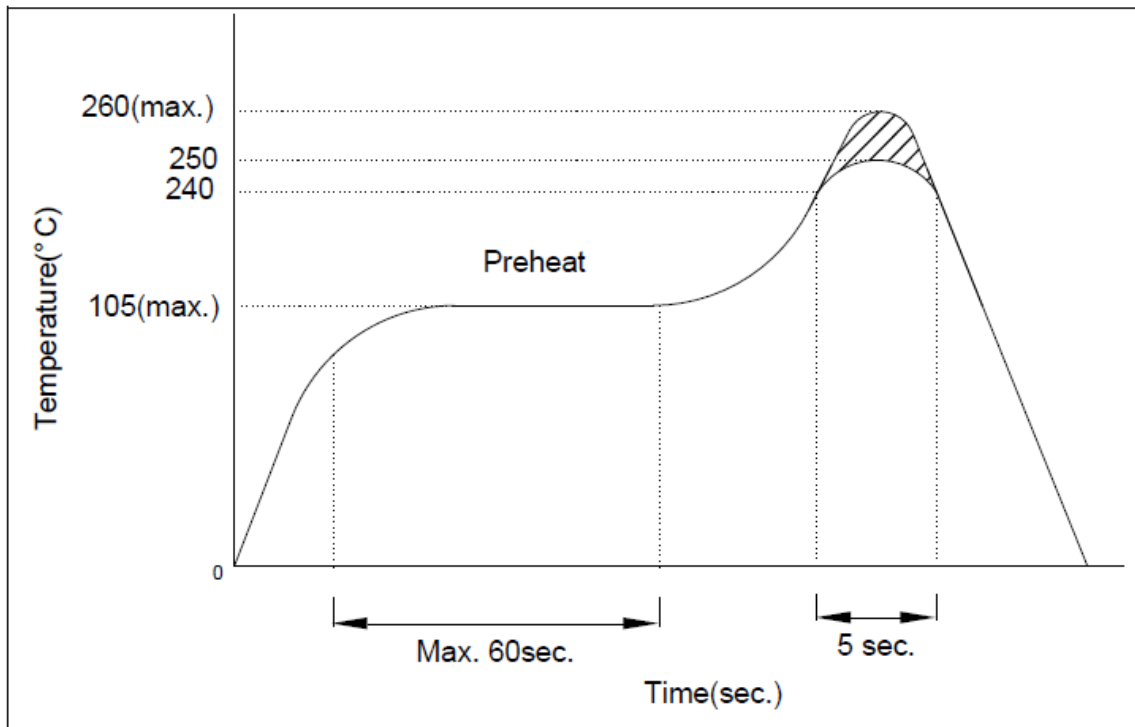

1.2 Soldering Iron

Power dissipation of iron should be smaller than 15W and temperature should be controllable. Surface temperature of iron tip should be under 230°C , soldering time ≤ 3 sec.

2. Electrostatic Discharge (ESD)

Static electricity or surge voltage will damage the LEDs.

Use of conductive wrist band or anti-electrostatic glove when handling these LEDs is recommended. All devices, equipment, work table, storage rack and machinery must be properly grounded.

In the events of manual working in process, make sure devices are well protected from ESD at all times.