

High-Brightness LED Driver Controller with High-Side Current Sense

Features

- 4.5V to 42V Input Voltage Range
- High Efficiency (>90%)
- $\pm 5\%$ LED Current Accuracy
- MIC3203: Dither Enabled for Low EMI
- MIC3203-1: Dither Disabled
- High-Side Current Sense
- Dedicated Dimming Control Input
- Hysteretic Control (No Compensation)
- Up to 1.5 MHz Switching Frequency
- Adjustable Constant LED Current
- Overtemperature Protection
- -40°C to $+125^{\circ}\text{C}$ Junction Temperature Range

Applications

- Architectural, Industrial, and Ambient Lighting
- LED Bulbs
- Indicators and Emergency Lighting
- Street Lighting
- Channel Letters
- 12V Lighting Systems (MR-16 Bulbs, Under-Cabinet Lighting, Garden/Pathway Lighting)

General Description

The MIC3203 is a hysteretic, step-down, constant-current, high-brightness LED (HB LED) driver. It provides an ideal solution for interior/exterior lighting, architectural and ambient lighting, LED bulbs, and other general illumination applications.

The MIC3203 is well suited for lighting applications that require a wide input voltage range. The hysteretic control gives good supply rejection and fast response during load transients and PWM dimming. The high-side current sensing and on-chip current-sense comparator delivers LED current with $\pm 5\%$ accuracy. An external high-side current-sense resistor is used to set the output current.

The MIC3203 offers a dedicated PWM input (DIM) that enables a wide range of pulsed dimming. A high-frequency switching operation up to 1.5 MHz allows the use of smaller external components minimizing space and cost. The MIC3203 offers frequency dither feature for EMI control.

The MIC3203 operates over a junction temperature from -40°C to $+125^{\circ}\text{C}$ and is available in an 8-pin SOIC package.

A dither disabled version MIC3203-1 is also available in the same package as the MIC3203.

Package Type

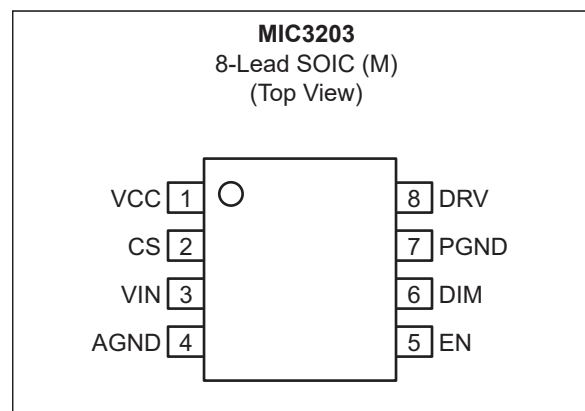

MIC3203/MIC3203-1

Typical Application Circuit

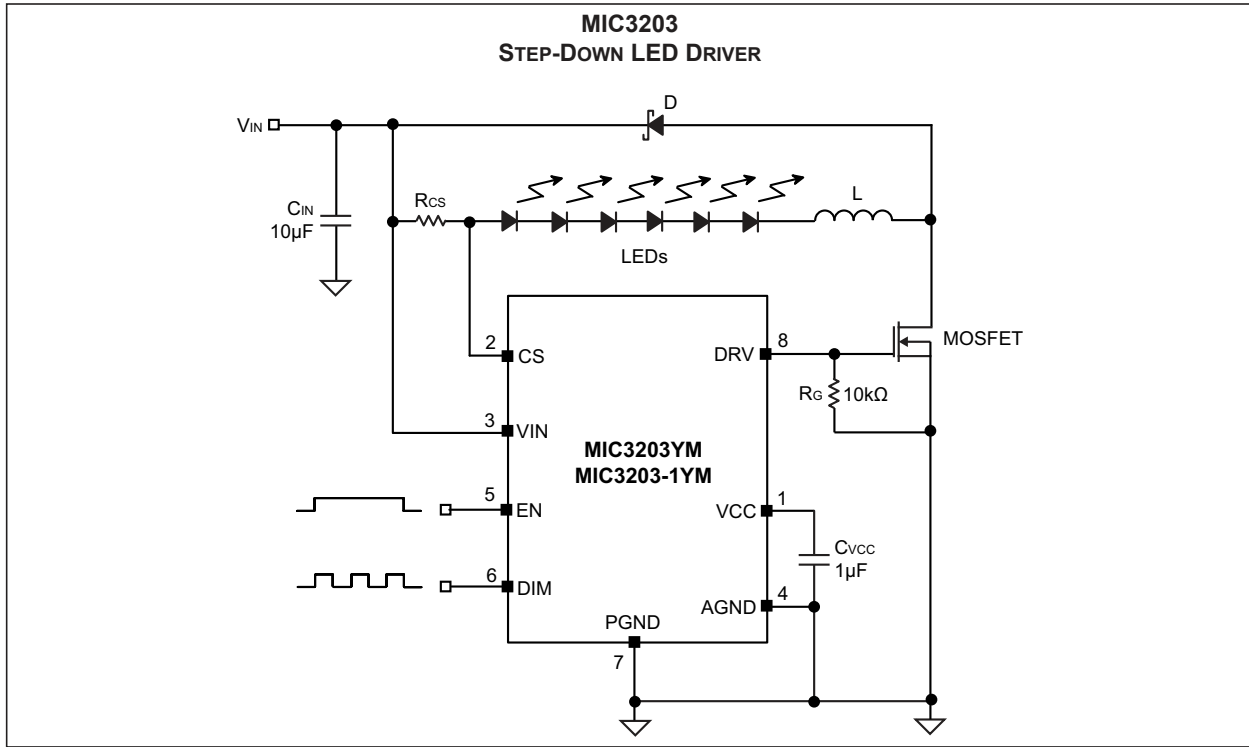

Functional Block Diagram

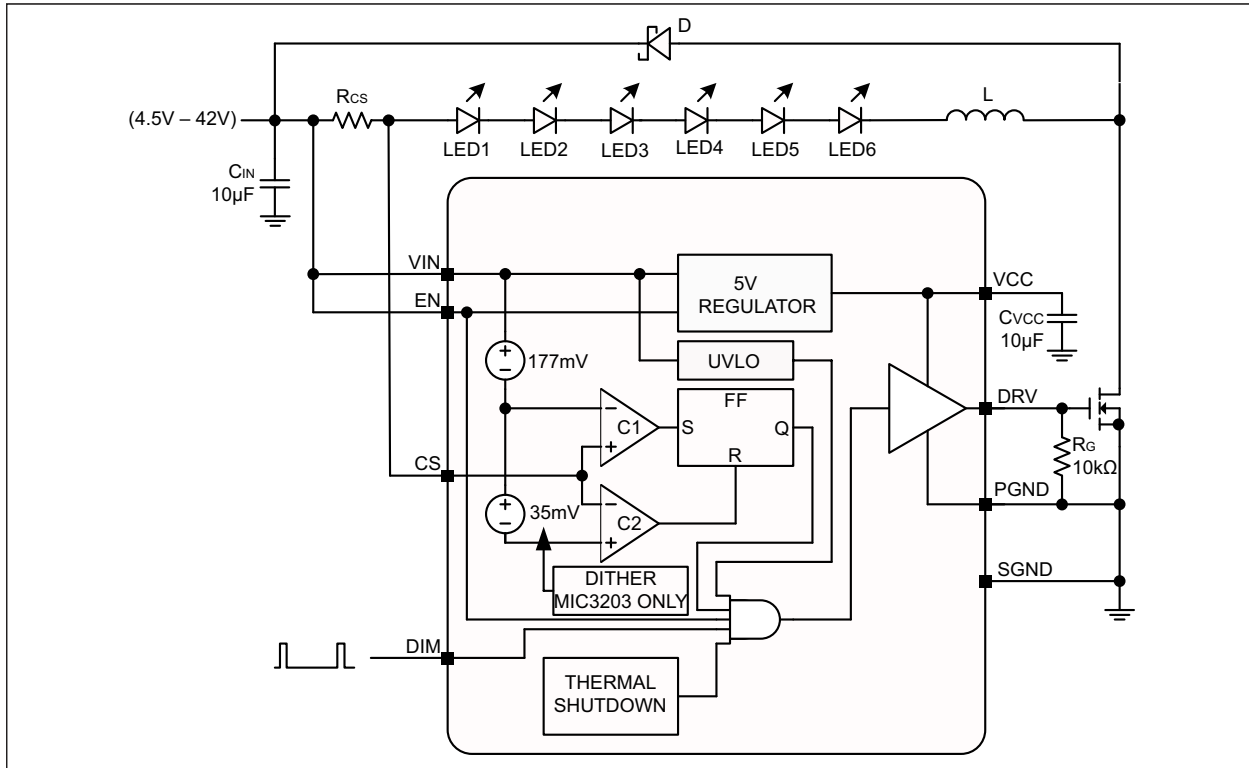

1.0 ELECTRICAL CHARACTERISTICS

Absolute Maximum Ratings †

V_{IN} to PGND	-0.3V to +45V
V_{CC} to PGND	-0.3V to +6.0V
CS to PGND.....	-0.3V to ($V_{IN} + 0.3V$)
EN to AGND.....	-0.3V to ($V_{IN} + 0.3V$)
DIM to AGND	-0.3V to ($V_{IN} + 0.3V$)
DRV to PGND	-0.3V to ($V_{CC} + 0.3V$)
PGND to AGND.....	-0.3V to +0.3V)
ESD Rating (Note 1)	1.5 kV, HBM
ESD Rating (Note 1)	200V, MM

Operating Ratings ††

Supply Voltage (V_{IN})	+4.5V to +42V
Enable Input Voltage (V_{EN})	0V to V_{IN}
Dimming Input Voltage (V_{DIM}).....	0V to V_{IN}

† **Notice:** Stresses above those listed under “Absolute Maximum Ratings” may cause permanent damage to the device. This is a stress rating only and functional operation of the device at those or any other conditions above those indicated in the operational sections of this specification is not intended. Exposure to maximum rating conditions for extended periods may affect device reliability.

†† **Notice:** The device is not guaranteed to function outside its operating ratings.

Note 1: Devices are ESD sensitive. Handling precautions are recommended. Human body model, 1.5 k Ω in series with 100 pF.

ELECTRICAL CHARACTERISTICS

Electrical Characteristics: $V_{IN} = V_{EN} = V_{DIM} = 12V$; $C_{VCC} = 1.0 \mu F$; $T_J = +25^\circ C$, **bold** values indicate $-40^\circ C \leq T_J \leq +125^\circ C$ unless noted. [Note 1](#)

Parameter	Sym.	Min.	Typ.	Max.	Units	Conditions
Input Supply						
Input Voltage Range	V_{IN}	4.5	—	42	V	—
Supply Current	I_S	—	1	3	mA	DRV = open
Shutdown Current	I_{SD}	—	—	1	μA	$V_{EN} = 0V$
V_{IN} UVLO Threshold	UVLO	3.2	4	4.5	V	V_{IN} rising
V_{IN} UVLO Hysteresis	UVLO _{HYS}	—	500	—	mV	—
VCC Supply						
VCC Output Voltage	V_{CC}	4.5	5	5.5	V	$V_{IN} = 12V$, $I_{CC} = 10 \text{ mA}$
Current Sense Comparator						
Current Sense Voltage Upper Threshold	$V_{CS(MAX)}$	201.4	212	222.6	mV	$V_{CS(MAX)} = V_{IN} - V_{CS}$
		199	212	225		
Current Sense Voltage Lower Threshold	$V_{CS(MIN)}$	168	177	186	mV	$V_{CS(MIN)} = V_{IN} - V_{CS}$
		165	177	189		
V_{CS} Hysteresis	V_{CSHYS}	—	35	—	mV	—

Note 1: Specification for packaged product only.

2: Guaranteed by design.

MIC3203/MIC3203-1

ELECTRICAL CHARACTERISTICS (CONTINUED)

Electrical Characteristics: $V_{IN} = V_{EN} = V_{DIM} = 12V$; $C_{VCC} = 1.0 \mu F$; $T_J = +25^\circ C$, **bold** values indicate $-40^\circ C \leq T_J \leq +125^\circ C$ unless noted. [Note 1](#)

Parameter	Sym.	Min.	Typ.	Max.	Units	Conditions
Current Sense Response Time	$t_{RES(CS)}$	—	50	—	ns	V_{CS} rising
		—	70	—		V_{CS} falling
CS Input Current	$I_{IN(CS)}$	—	0.5	10	μA	$V_{IN} - V_{CS} = 220 mV$
Frequency						
Switching Frequency	f_{SW}	—	—	1.5	MHz	—
Dithering (MIC3203)						
V_{CS} Hysteresis Dithering Range (Note 2)	V_{DITH}	—	± 6	—	mV	—
Frequency Dithering Range (Note 2)	f_{DITHER}	—	± 12	—	%	Percent of Switching Frequency
Enable Input						
EN Logic Level High	V_{ENH}	2.2	—	—	V	—
EN Logic Level Low	V_{ENL}	—	—	0.4	V	—
EN Bias Current	I_{EN}	—	—	60	μA	$V_{EN} = 12V$
		—	—	1		$V_{EN} = 0V$
Start-Up Time	t_{START}	—	30	—	μs	From EN pin going high to DRV going high
Dimming Input						
DIM Logic Level High	V_{DIMH}	2.0	—	—	V	—
DIM Logic Level Low	V_{DIML}	—	—	0.4	V	—
DIM Bias Current	I_{DIM}	—	20	50	μA	—
		—	—	1		$V_{DIM} = 0V$
DIM Delay Time	t_{DLY}	—	450	—	ns	From DIM pin going high to DRV going high
Maximum Dimming Frequency	f_{DIM}	—	—	20	kHz	—
External FET Driver						
DRV On-Resistance	$R_{DRV(ON)}$	—	2	—	Ω	Pull-Up, $I_{SOURCE} = 10 mA$
		—	1.5	—		Pull-Down, $I_{SINK} = -10 mA$
DRV Transition Time	t_r/t_f	—	13	—	ns	Rise Time, $C_{LOAD} = 1000 pF$
		—	7	—		Fall Time, $C_{LOAD} = 1000 pF$
Thermal Protection						
Overtemperature Shutdown Threshold	T_{LIM}	—	160	—	$^\circ C$	T_J rising
Overtemperature Shutdown Hysteresis	T_{LIMHYS}	—	20	—	$^\circ C$	—

Note 1: Specification for packaged product only.

2: Guaranteed by design.

TEMPERATURE SPECIFICATIONS

Parameters	Sym.	Min.	Typ.	Max.	Units	Conditions
Temperature Ranges						
Operating Junction Temperature Range	T_J	-40	—	+125	°C	Note 1
Maximum Junction Temperature	$T_{J(MAX)}$	—	—	+150	°C	—
Storage Temperature Range	T_S	-60	—	+150	°C	—
Lead Temperature	T_{LEAD}	—	—	+260	°C	Soldering, 10 sec.
Package Thermal Resistance						
Thermal Resistance, SOIC 8-Ld	θ_{JA}	—	98.9	—	°C/W	—
Thermal Resistance, SOIC 8-Ld	θ_{JC}	—	48.8	—	°C/W	—

Note 1: The maximum allowable power dissipation is a function of ambient temperature, the maximum allowable junction temperature and the thermal resistance from junction to air (i.e., T_A , T_J , θ_{JA}). Exceeding the maximum allowable power dissipation will cause the device operating junction temperature to exceed the maximum +125°C rating. Sustained junction temperatures above +125°C can impact the device reliability.

MIC3203/MIC3203-1

2.0 TYPICAL PERFORMANCE CURVES

Note: The graphs and tables provided following this note are a statistical summary based on a limited number of samples and are provided for informational purposes only. The performance characteristics listed herein are not tested or guaranteed. In some graphs or tables, the data presented may be outside the specified operating range (e.g., outside specified power supply range) and therefore outside the warranted range.

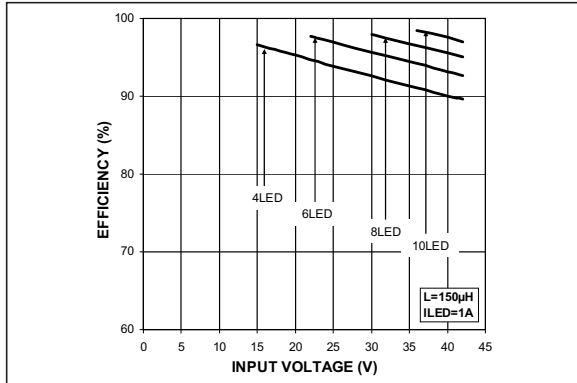

FIGURE 2-1: Efficiency vs. Input Voltage ($L = 150 \mu\text{H}$, $I_{LED} = 1\text{A}$).

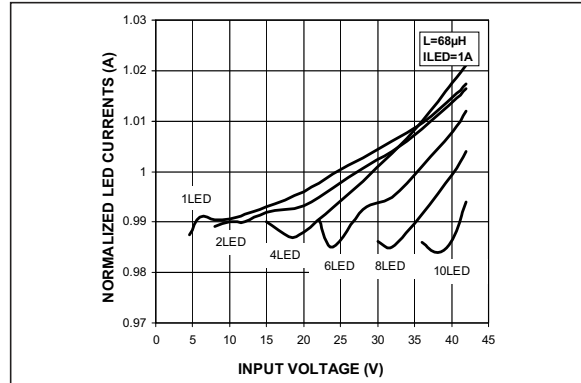

FIGURE 2-4: Normalized LED Currents vs. Input Voltage ($L = 68 \mu\text{H}$, $I_{LED} = 1\text{A}$).

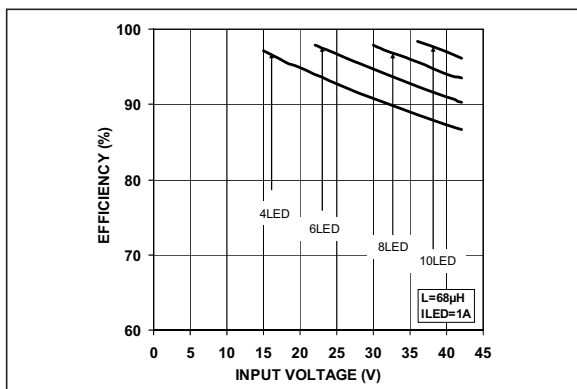

FIGURE 2-2: Efficiency vs. Input Voltage ($L = 68 \mu\text{H}$, $I_{LED} = 1\text{A}$).

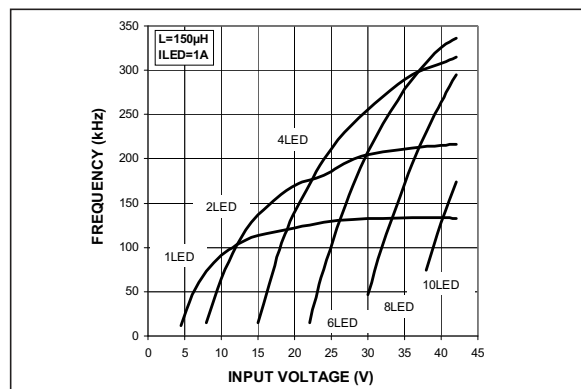

FIGURE 2-5: Frequency vs. Input Voltage ($L = 150 \mu\text{H}$, $I_{LED} = 1\text{A}$).

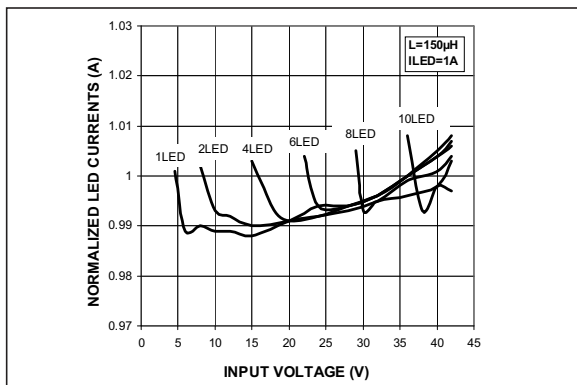

FIGURE 2-3: Normalized LED Currents vs. Input Voltage ($L = 150 \mu\text{H}$, $I_{LED} = 1\text{A}$).

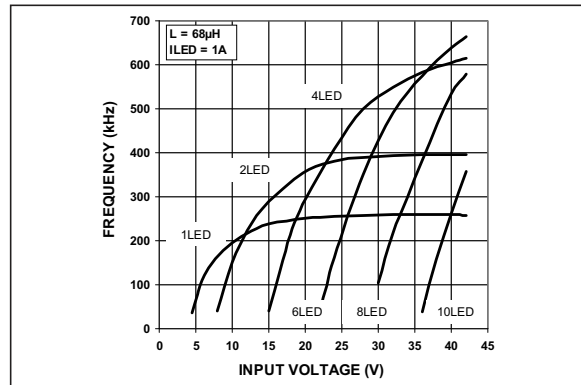

FIGURE 2-6: Frequency vs. Input Voltage ($L = 68 \mu\text{H}$, $I_{LED} = 1\text{A}$).

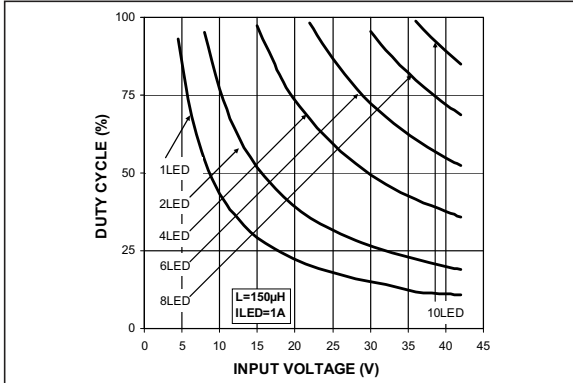

FIGURE 2-7: Duty Cycle vs. Input Voltage ($L = 150 \mu\text{H}$, $I_{LED} = 1\text{A}$).

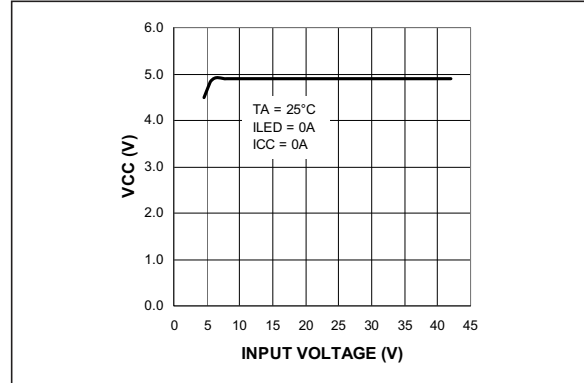

FIGURE 2-10: VCC vs. Input Voltage.

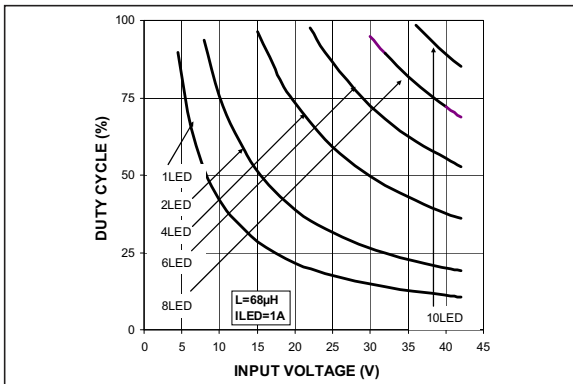

FIGURE 2-8: Duty Cycle vs. Input Voltage ($L = 68 \mu\text{H}$, $I_{LED} = 1\text{A}$).

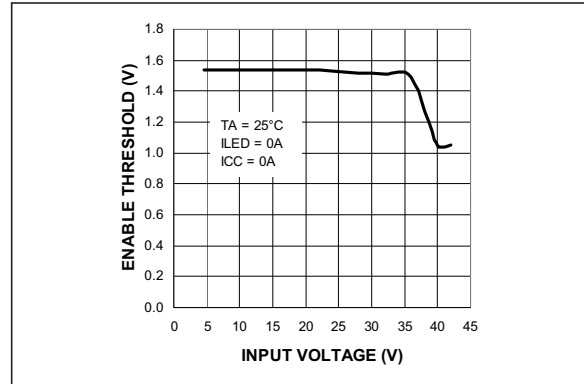

FIGURE 2-11: Enable Threshold vs. Input Voltage.

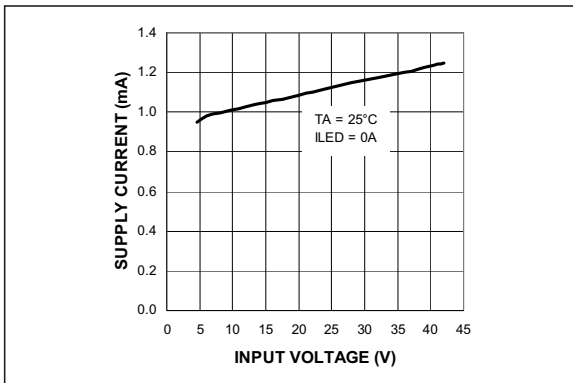

FIGURE 2-9: Supply Current vs. Input Voltage.

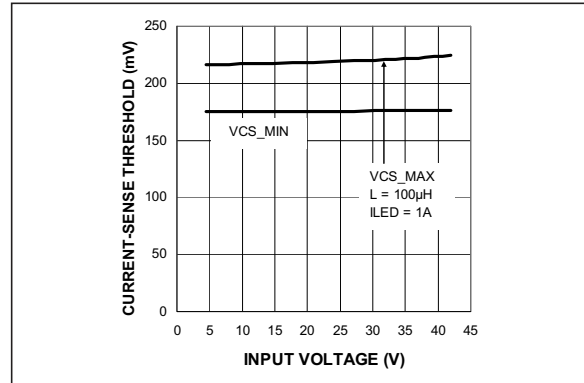

FIGURE 2-12: Current-Sense Threshold vs. Input Voltage.

MIC3203/MIC3203-1

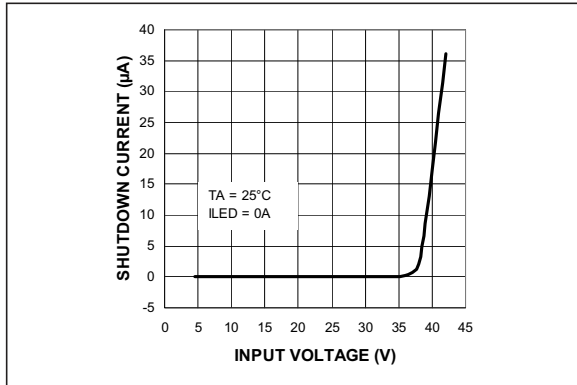

FIGURE 2-13: Shutdown Current vs. Input Voltage.

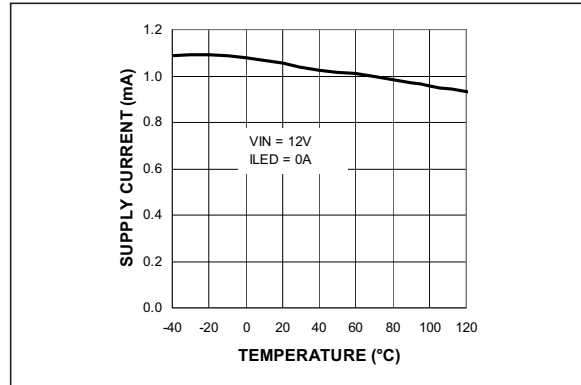

FIGURE 2-16: Supply Current vs. Temperature.

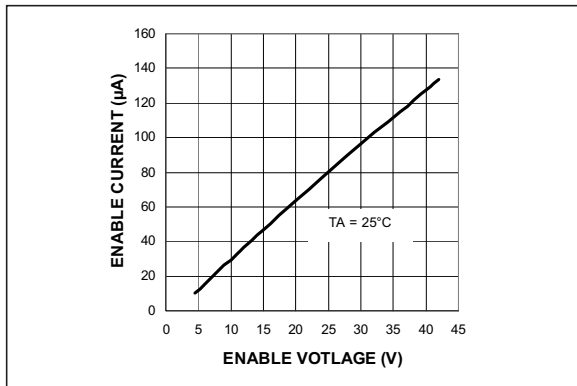

FIGURE 2-14: Enable Current vs. Enable Voltage.

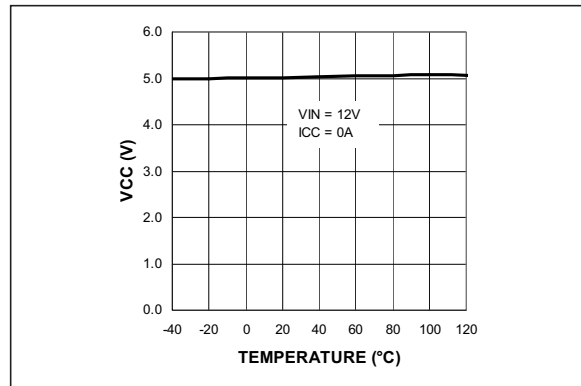

FIGURE 2-17: VCC vs. Temperature.

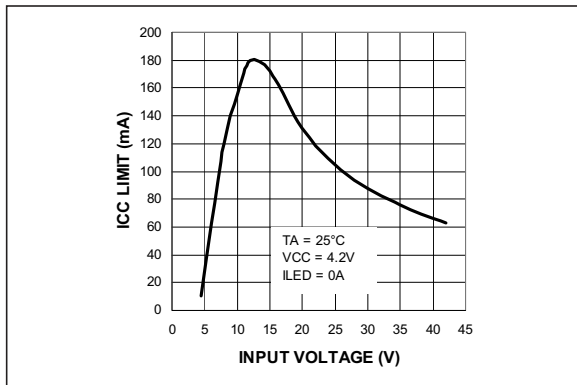

FIGURE 2-15: ICC Limit vs. Input Voltage.

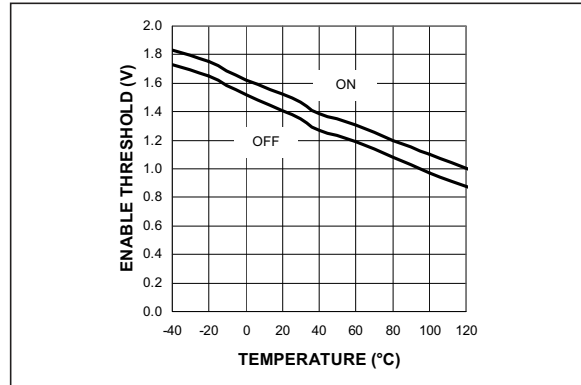

FIGURE 2-18: Enable Threshold vs. Temperature.

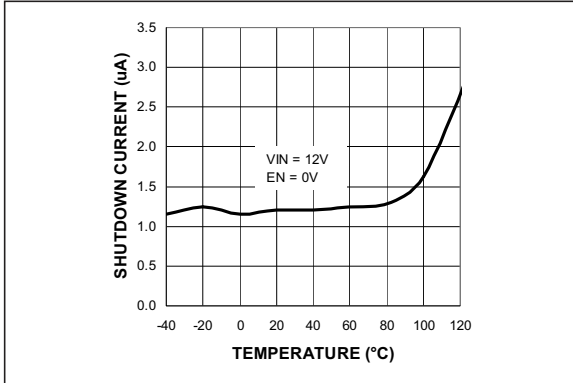

FIGURE 2-19: Shutdown Current vs. Temperature.

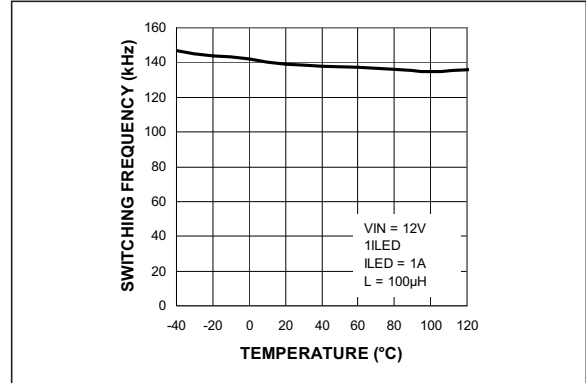

FIGURE 2-22: Switching Frequency vs. Temperature.

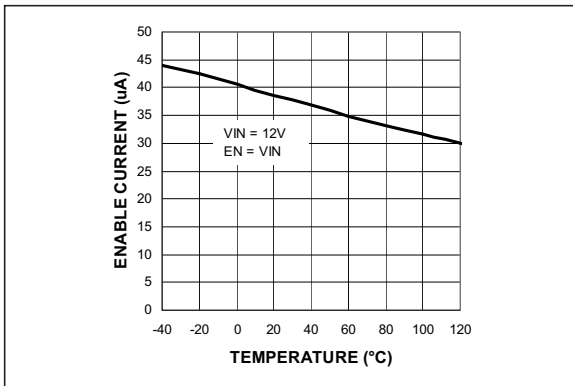

FIGURE 2-20: Enable Current vs. Temperature.

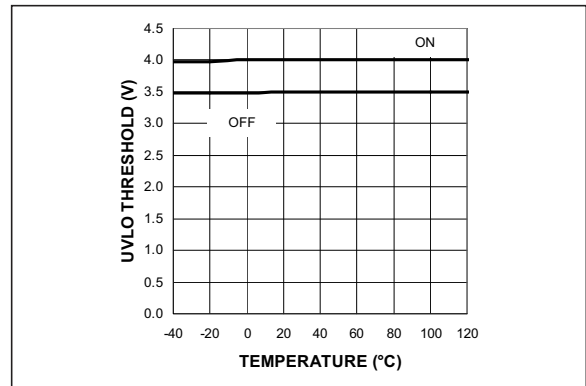

FIGURE 2-23: UVLO Threshold vs. Temperature.

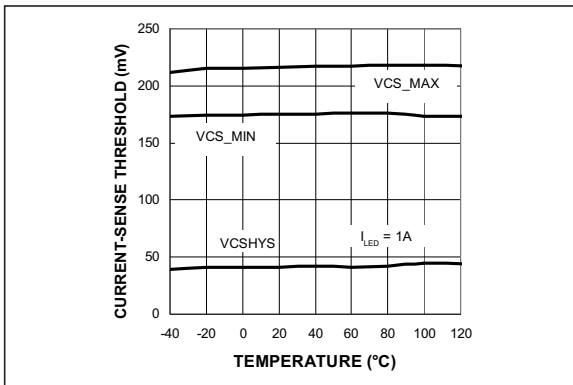

FIGURE 2-21: Current-Sense Voltage vs. Temperature.

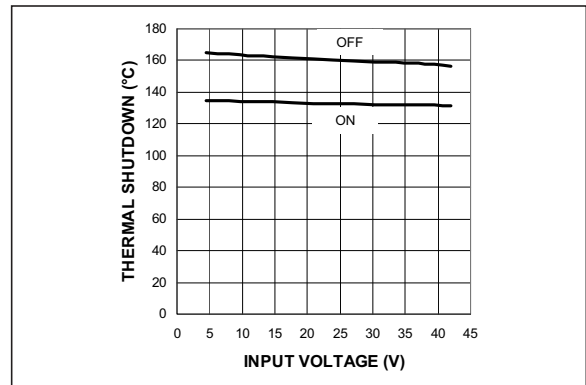

FIGURE 2-24: Thermal Shutdown Threshold vs. Input Voltage.

MIC3203/MIC3203-1

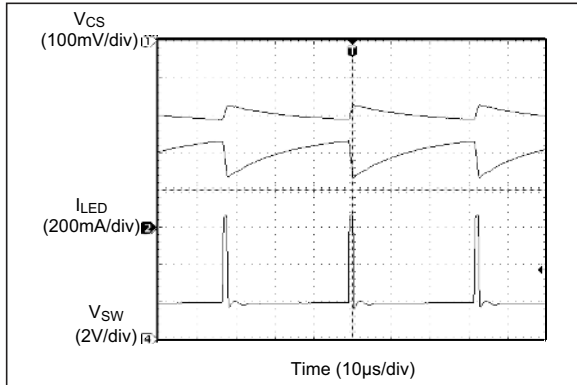

FIGURE 2-25: Steady-State Operation at $V_{IN} = 6V$.

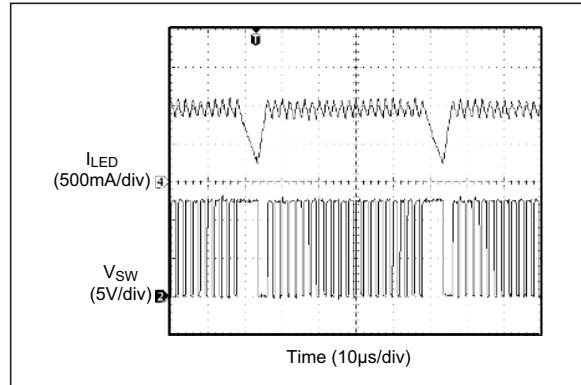

FIGURE 2-28: PWM Dimming at 20 kHz ($V_{IN} = 12V$, 90% Duty Cycle).

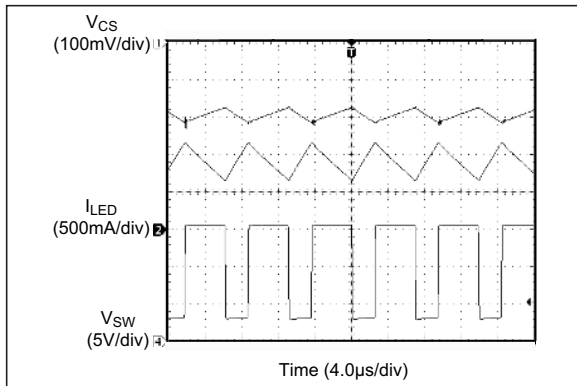

FIGURE 2-26: PWM Dimming at 20 kHz ($V_{IN} = 6V$, 10% Duty Cycle).

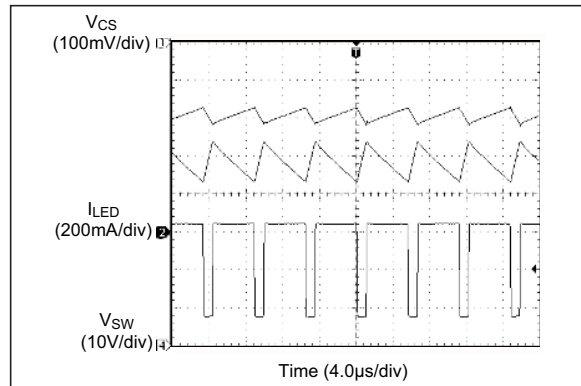

FIGURE 2-29: Steady-State Operation at $V_{IN} = 24V$.

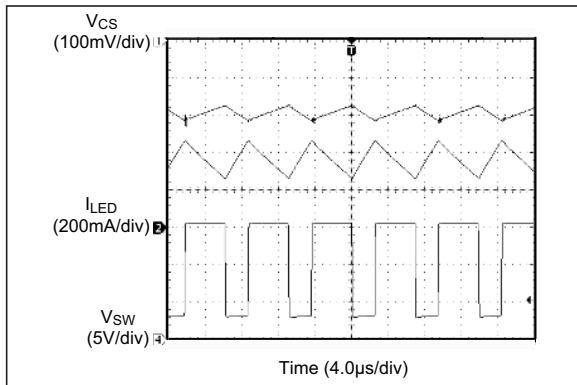

FIGURE 2-27: Steady-State Operation at $V_{IN} = 12V$.

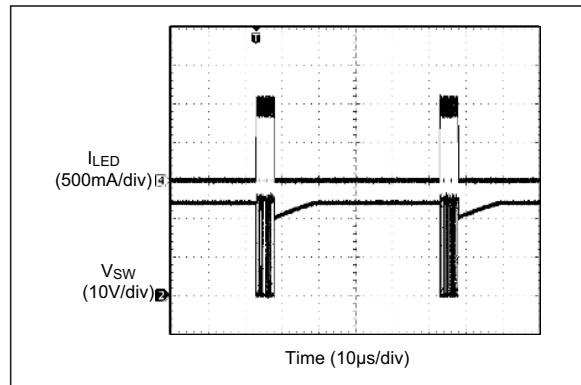

FIGURE 2-30: PWM Dimming at 20 kHz ($V_{IN} = 24V$, 10% Duty Cycle).

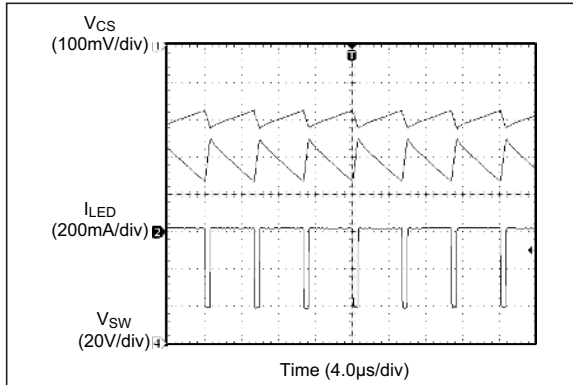

FIGURE 2-31: Steady-State Operation at $V_{IN} = 42V$.

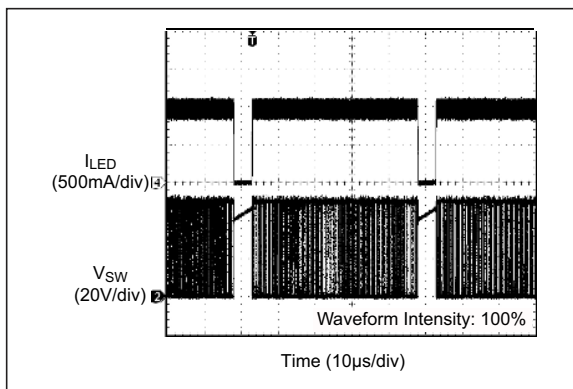

FIGURE 2-32: PWM Dimming at 20 kHz ($V_{IN} = 42V$, 0% Duty Cycle).

MIC3203/MIC3203-1

3.0 PIN DESCRIPTIONS

The descriptions of the pins are listed in [Table 3-1](#).

TABLE 3-1: PIN FUNCTION TABLE

Pin Number	Pin Name	Description
1	VCC	Voltage Regulator Output. The VCC pin supplies the power to the internal circuitry. The V _{CC} is the output of a linear regulator which is powered from VIN. A 1 μ F ceramic capacitor is recommended for bypassing and should be placed as close as possible to the VCC and AGND pins. Do not connect to an external load.
2	CS	Current-Sense Input. The CS pin provides the high-side current sense to set the LED current with an external sense resistor.
3	VIN	Input Power Supply. VIN is the input supply pin to the internal circuitry and the positive input to the current sense comparator. Due to the high frequency switching noise, a 10 μ F ceramic capacitor is recommended to be placed as close as possible to VIN and the power ground (PGND) pins for bypassing. Please refer to layout recommendations.
4	AGND	Ground pin for analog circuitry. Internal signal ground for all low power sections.
5	EN	Enable Input. The EN pin provides a logic level control of the output and the voltage has to be 2.2V or higher to enable the current regulator. The output stage is gated by the DIM pin. When the EN pin is pulled low, the regulator goes to off state and the supply current of the device is greatly reduced (below 1 μ A). In the off state, during this period the output drive is placed in a "tri-stated" condition, where MOSFET is in an "off" or non-conducting state. Do not drive the EN pin above the supply voltage.
6	DIM	PWM Dimming Input. The DIM pin provides the control for brightness of the LED. A PWM input can be used to control the brightness of LED. DIM high enables the output and its voltage has to be at least 2.0V or higher. DIM low disables the output, regardless of EN "high" state.
7	PGND	Power Ground Pin for Power FET. Power Ground (PGND) is for the high-current switching with hysteretic mode. The current loop for the power ground should be as small as possible and separate from the Analog ground (AGND) loop. Refer to the layout considerations for more details.
8	DRV	Gate-Drive Output. Connect to the gate of an external N-channel MOSFET. The drain of the external MOSFET connects directly to the inductor and provides the switching current necessary to operate in hysteretic mode. Due to the high frequency switching and high voltage associated with this pin, the switch node should be routed away from sensitive nodes.

4.0 FUNCTIONAL DESCRIPTION

The MIC3203 is a hysteretic step-down driver that regulates the LED current over a wide input voltage range.

The device operates from a 4.5V to 42V input supply voltage range and provides up to 0.5A source and 1A sink drive capability. When the input voltage reaches 4.5V, the internal 5V V_{CC} is regulated and the DRV pin is pulled high to turn on an external MOSFET if the EN pin and DIM pin are high. The inductor current builds up linearly. When the CS pin voltage hits the $V_{CS(MAX)}$ with respect to V_{IN} , the MOSFET turns off and the Schottky diode takes over and returns the current to V_{IN} . Then the current, through inductor and LEDs, starts decreasing linearly. When the CS pin voltage, with respect to V_{IN} pin voltage, hits $V_{CS(MIN)}$, the MOSFET turns on and the cycle repeats.

The frequency of operation depends upon input voltage, total LEDs voltage drop, LED current, and temperature. The calculation for frequency of operation is given in the [Application Information](#) section.

The MIC3203 has an on board 5V regulator that is for internal use only. Connect a 1 μ F capacitor on the VCC pin to analog ground.

The MIC3203 has an EN pin that gives the flexibility to enable and disable the IC device with logic high and low signals.

The MIC3203 also has a DIM pin that can turn on and off the LEDs if EN is in “high” state. This DIM pin controls the brightness of the LED by varying the duty cycle of DIM pin from 1% to 99%.

MIC3203/MIC3203-1

5.0 APPLICATION INFORMATION

The internal [Functional Block Diagram](#) of the MIC3203 is shown on Page 2. The MIC3203 is composed of a current-sense comparator, voltage and current reference, 5V regulator, and MOSFET driver. Hysteretic mode control is a topology that does not employ an error amplifier, it uses an error comparator instead.

The inductor current is controlled within a hysteretic window. If the inductor current is too small, the power MOSFET is turned on; if the inductor current is large enough, the power MOSFET is turned off. It is a simple control scheme with no oscillator and no loop compensation. Because the control scheme does not need loop compensation, it makes a design easy and avoids problems of instability.

Transient response to load and line variation is very fast and only depends on propagation delay. This makes the control scheme very popular for certain applications.

5.1 LED Current and R_{CS}

The main feature in MIC3203 is to control the LED current accurately within ±5% of a set current. Choosing a high-side R_{CS} resistor helps with setting constant LED current regardless of a wide input voltage range. The following equation gives the R_{CS} value:

EQUATION 5-1:

$$R_{CS} = \frac{1}{2} \times \left(\frac{V_{CS(MAX)} + V_{CS(MIN)}}{I_{LED}} \right)$$

TABLE 5-1: R_{CS} FOR LED CURRENT

R _{CS}	I _{LED}	I ² R	Size (SMD)
1.33Ω	0.15A	0.03W	0603
0.56Ω	0.35A	0.07W	0805
0.4Ω	0.5A	0.1W	0805
0.28Ω	0.7A	0.137W	1206
0.2Ω	1.0A	0.2W	1206
0.13Ω	1.5A	0.3W	1210
0.1Ω	2.0A	0.4W	2010
0.08Ω	2.5A	0.5W	2010
0.068Ω	3.0A	0.6W	2010

For V_{CS(MAX)} and V_{CS(MIN)}, refer to the [Electrical Characteristics](#) table.

5.2 Frequency of Operation

To calculate the frequency spread across input supply:

EQUATION 5-2:

$$V_L = L \times \frac{\Delta I_L}{\Delta t}$$

L is the inductance, ΔI_L is fixed (the value of the hysteresis):

EQUATION 5-3:

$$\Delta I_L = \frac{V_{CS(MAX)} - V_{CS(MIN)}}{R_{CS}}$$

V_L is the voltage across inductor L, which varies by supply.

For current rising (MOSFET is ON):

EQUATION 5-4:

$$t_r = L \times \frac{\Delta I_L}{V_{L_RISE}}$$

Where:
V_{L_RISE} = V_{IN} - I_{LED} × R_{CS} - V_{LED}

For current falling (MOSFET is OFF):

EQUATION 5-5:

$$t_f = L \times \frac{\Delta I_L}{V_{L_FALL}}$$

Where:
V_{L_FALL} = V_D + I_{LED} × R_{CS} + V_{LED}

EQUATION 5-6:

$$T = t_r + t_f$$

$$f_{SW} = \frac{1}{T}$$

$$f_{SW} = \frac{(V_D + I_{LED} \times R_{CS} + V_{LED}) \times (V_{IN} - I_{LED} \times R_{CS} - V_{LED})}{L \times \Delta I_L \times (V_D + V_{IN})}$$

Where:
 V_D = Schottky diode forward drop.
 V_{LED} = Total LEDs voltage drop.
 V_{IN} = Input voltage.
 I_{LED} = Average LED current.

5.3 Inductor

According to the above equation, choose the inductor to make the operating frequency no higher than 1.5 MHz. The following tables give a reference inductor value and corresponding frequency for a given LED current. For space-sensitive applications, a smaller inductor with higher switching frequency can be used, but the efficiency of the regulator will be reduced.

TABLE 5-2: INDUCTOR FOR $V_{IN} = 12V$, 1 LED

R_{CS}	I_{LED}	L	f_{SW}
1.33Ω	0.15A	220 μH	474 kHz
0.56Ω	0.35A	100 μH	439 kHz
0.4Ω	0.5A	68 μH	461 kHz
0.28Ω	0.7A	47 μH	467 kHz
0.2Ω	1.0A	33 μH	475 kHz
0.13Ω	1.5A	22 μH	463 kHz
0.1Ω	2.0A	15 μH	522 kHz
0.08Ω	2.5A	12 μH	522 kHz
0.068Ω	3.0A	10 μH	533 kHz

TABLE 5-3: INDUCTOR FOR $V_{IN} = 24V$, 4LEDS

R_{CS}	I_{LED}	L	f_{SW}
1.33Ω	0.15A	470 μH	474 kHz
0.56Ω	0.35A	220 μH	426 kHz
0.4Ω	0.5A	150 μH	447 kHz
0.28Ω	0.7A	100 μH	470 kHz
0.2Ω	1.0A	68 μH	493 kHz
0.13Ω	1.5A	47 μH	463 kHz
0.1Ω	2.0A	33 μH	507 kHz
0.08Ω	2.5A	27 μH	496 kHz
0.068Ω	3.0A	22 μH	517 kHz

TABLE 5-4: INDUCTOR FOR $V_{IN} = 36V$ 8 LEDES

R_{CS}	I_{LED}	L	f_{SW}
1.33Ω	0.15A	470 μH	495 kHz
0.56Ω	0.35A	220 μH	446 kHz
0.4Ω	0.5A	150 μH	467 kHz
0.28Ω	0.7A	100 μH	490 kHz
0.2Ω	1.0A	68 μH	515 kHz
0.13Ω	1.5A	47 μH	485 kHz
0.1Ω	2.0A	33 μH	530 kHz
0.08Ω	2.5A	27 μH	519 kHz
0.068Ω	3.0A	22 μH	541 kHz

Given an inductor value, the size of the inductor can be determined by its RMS and peak current rating.

EQUATION 5-7:

$$\frac{\Delta I_L}{I_L} = 2 \times \frac{V_{CS(MAX)} - V_{CS(MIN)}}{V_{CS(MAX)} + V_{CS(MIN)}} = 0.18$$

$$I_{L(RMS)} = \sqrt{I_L^2 + \frac{1}{12} \times \Delta I_L^2} \approx I_L$$

$$I_{L(PK)} = I_L + \frac{1}{2} \Delta I_L = 1.09 I_L$$

Where:
 I_L = Average inductor current.

Select an inductor with saturation current rating at least 30% higher than the peak current.

MIC3203/MIC3203-1

5.4 MOSFET

MOSFET selection depends upon the maximum input voltage, output LED current, and switching frequency.

The selected MOSFET should have a 30% margin on the maximum voltage rating for high reliability requirements.

The MOSFET channel resistance $R_{DS(ON)}$ is selected such that it helps to get the required efficiency at the required LED currents as well as meets the cost requirement.

Logic level MOSFETs are preferred because the drive voltage is limited to 5V.

The MOSFET power loss has to be calculated for proper operation. The power loss consists of conduction loss and switching loss. The conduction loss can be found by:

EQUATION 5-8:

$$P_{LOSS(CON)} = I_{FET(RMS)}^2 \times R_{DS(ON)}$$

$$I_{FET(RMS)} = I_{LED} \times \sqrt{D}$$

$$D = \frac{V_{TOTAL\ LED}}{V_{IN}}$$

The switching loss occurs during the MOSFET turn-on and turn-off transition and can be found by:

EQUATION 5-9:

$$P_{LOSS(TRAN)} = \frac{V_{IN} \times I_{LED} \times f_{SW}}{I_{DRV}} \times (Q_{gs2} + Q_{gd})$$

$$I_{DRV} = \frac{V_{DRV}}{R_{GATE}}$$

Where:

R_{GATE} = Total MOSFET gate resistance and gate driver resistance. Q_{gs2} and Q_{gd} can be found in a MOSFET manufacturer's data sheet.

The total power loss is:

EQUATION 5-10:

$$P_{LOSS(TOT)} = P_{LOSS(CON)} + P_{LOSS(TRAN)}$$

The MOSFET junction temperature is given by:

EQUATION 5-11:

$$T_J = P_{LOSS(TOT)} \times \theta_{JA} + T_A$$

The T_J must not exceed maximum junction temperature under any conditions.

5.5 Freewheeling Diode

The freewheeling diode should have the reverse voltage rating to accommodate the maximum input voltage. The forward voltage drop should be small in order to get the lowest conduction dissipation for high efficiency. The forward current rating has to be at least equal to the LED current. A Schottky diode is recommended for highest efficiency.

5.6 Input Capacitor

The ceramic input capacitor is selected by voltage rating and ripple current rating. To determine the input capacitor ripple current rating, the RMS value of the input capacitor current can be found by:

EQUATION 5-12:

$$I_{CIN(RMS)} = I_{LED} \times \sqrt{D \times (1 - D)}$$

The input capacitor ripple current rating can be considered as $I_{LED}/2$ under the worst condition, $D = 50\%$.

The power loss in the input capacitor is:

EQUATION 5-13:

$$P_{LOSS(CIN)} = I_{CIN(RMS)}^2 \times ESR_{CIN}$$

5.7 LED Ripple Current

The LED current is the same as inductor current. If the LED ripple current needs to be reduced, then place a 4.7 μ F/50V ceramic capacitor across the LED.

5.8 Frequency Dithering

The MIC3203 is designed to reduce EMI by dithering the switching frequency $\pm 12\%$ in order to spread the frequency spectrum over a wider range. This lowers the EMI noise peaks generated by the switching regulator.

Switching regulators generate noise by their nature and they are the main EMI source to interference with nearby circuits. If the switching frequency of a regulator is modulated via frequency dithering, the energy of the EMI is spread among many frequencies instead of concentrated at fundamental switching frequency and its harmonics. The MIC3203 modulates the $V_{CS(MAX)}$ with amplitude $\pm 6mV$ by a pseudo random generator to generate the $\pm 12\%$ of the switching frequency dithering to reduce the EMI noise peaks.

MIC3203/MIC3203-1

6.0 PCB LAYOUT GUIDELINES

PCB layout is critical to achieve reliable, stable, and efficient performance. A ground plane is required to control EMI and minimize the inductance in power and signal return paths.

To minimize EMI and output noise, and to ensure proper operation of the MIC3203 regulator, follow these guidelines.

6.1 IC

- Use thick traces to route the input and output power lines.
- Signal and power grounds should be kept separate and connected at only one location.

6.2 Input Capacitor

- Place the input capacitors on the same side of the board and as close to the IC as possible.
- Keep both the VIN and PGND traces as short as possible.
- Place several vias to the ground plane close to the input capacitor ground terminal, but not between the input capacitors and IC pins.
- Use either X7R or X5R dielectric ceramic input capacitors. Do not use Y5V or Z5U type capacitors.
- Do not replace the ceramic input capacitor with any other type of capacitor. Any type of capacitor can be placed in parallel with the ceramic input capacitor.
- If a Tantalum input capacitor is placed in parallel with the input capacitor, it must be recommended for switching regulator applications and the operating voltage must be derated by 50%.
- In “Hot-Plug” applications, a Tantalum or Electrolytic bypass capacitor must be placed in parallel to ceramic capacitor to limit the overvoltage spike seen on the input supply with power is suddenly applied. In this case, an additional Tantalum or Electrolytic bypass input capacitor of 22 μF or higher is required at the input power connection if necessary.

6.3 Inductor

- Keep the inductor connection to the switch node (MOSFET drain) short.
- Do not route any digital lines underneath or close to the inductor.
- To minimize noise, place a ground plane underneath the inductor.

6.4 Output Capacitor

- If LED ripple current needs to be reduced, then place a 4.7 $\mu\text{F}/50\text{V}$ capacitor across the LED. The capacitor must be placed as close to the LED as possible.

6.5 MOSFET

- Place the MOSFET as close as possible to the MIC3203 to avoid trace inductance. Provide sufficient copper area on the MOSFET ground to dissipate the heat.

6.6 Diode

- Place the Schottky diode on the same side of the board as the IC and input capacitor.
- The connection from the Schottky diode's anode to the switching node must be as short as possible.
- The diode's cathode connection to the R_{CS} must be kept as short as possible.

6.7 RC Snubber

- If an RC snubber is needed, place the RC snubber on the same side of the board and as close to the Schottky diode as possible.

6.8 Current Sense Resistor (R_{CS})

- The VIN pin and CS pin must be as close as possible to R_{CS} . Make a Kelvin connection to the VIN and CS pins respectively for current sensing.

6.9 Trace Routing Recommendation

- Keep the power traces as short and wide as possible. One current flowing loop is during the MOSFET ON-time, the traces connecting the input capacitor C_{IN} , R_{CS} , LEDs, inductor, the MOSFET, and back to C_{IN} . The other current flowing loop is during the MOSFET OFF-time, the traces connecting R_{CS} , LED, inductor, freewheeling diode, and back to R_{CS} . These two loop areas should be kept as small as possible to minimize the noise interference,
- Keep all analog signal traces away from the switching node and its connecting traces.

7.0 RIPPLE MEASUREMENTS

To properly measure ripple on either input or output of a switching regulator, a proper ring in tip measurement is required. Standard oscilloscope probes come with a grounding clip or a long wire with an alligator clip. Unfortunately, for high-frequency measurements, this ground clip can pick-up high-frequency noise and erroneously inject it into the measured output ripple.

The standard evaluation board accommodates a homemade version by providing probe points for both the input and output supplies and their respective grounds. This requires the removing of the oscilloscope probe sheath and ground clip from a standard oscilloscope probe and wrapping a non-shielded bus wire around the oscilloscope probe. If there does not happen to be any non-shielded bus wire immediately available, the leads from axial resistors will work. By maintaining the shortest possible ground lengths on the oscilloscope probe, true ripple measurements can be obtained.

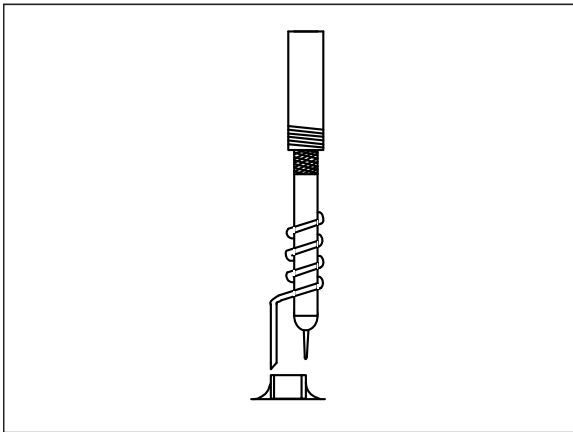

FIGURE 7-1: *Low Noise Measurement.*

MIC3203/MIC3203-1

8.0 PACKAGING INFORMATION

8.1 Package Marking Information

8-Lead SOIC*
Dither Enabled

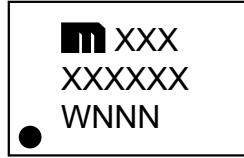

Example

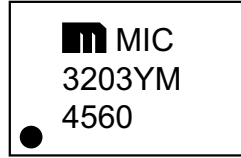

8-Lead SOIC*
Dither Disabled

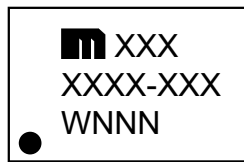

Example

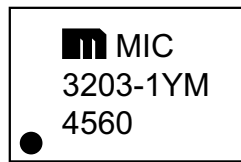

Legend:	XX...X	Product code or customer-specific information
	Y	Year code (last digit of calendar year)
	YY	Year code (last 2 digits of calendar year)
	WW	Week code (week of January 1 is week '01')
	NNN	Alphanumeric traceability code
	(e3)	Pb-free JEDEC [®] designator for Matte Tin (Sn)
	*	This package is Pb-free. The Pb-free JEDEC designator ((e3)) can be found on the outer packaging for this package.
	•, ▲, ▼	Pin one index is identified by a dot, delta up, or delta down (triangle mark).

Note: In the event the full Microchip part number cannot be marked on one line, it will be carried over to the next line, thus limiting the number of available characters for customer-specific information. Package may or may not include the corporate logo.

Underbar (¯) and/or Overbar (˘) symbol may not be to scale.

8-Lead SOIC Package Outline and Recommended Land Pattern

TITLE

8 LEAD SOICN PACKAGE OUTLINE & RECOMMENDED LAND PATTERN

DRAWING #	SOICN-8LD-PL-1	UNIT	INCH [MM]
-----------	----------------	------	-----------

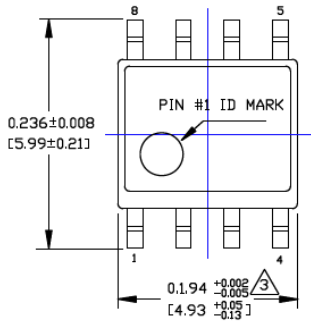

TOP VIEW

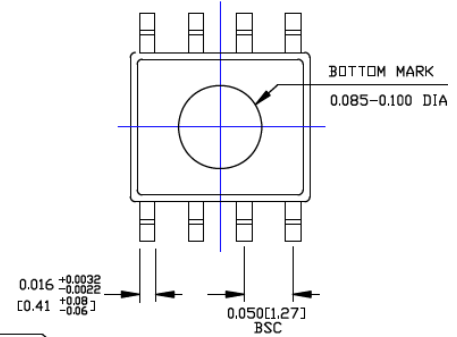

BOTTOM VIEW

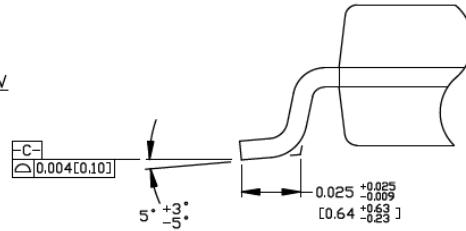

DETAIL "A"

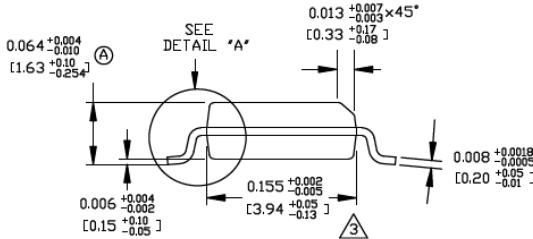

END VIEW

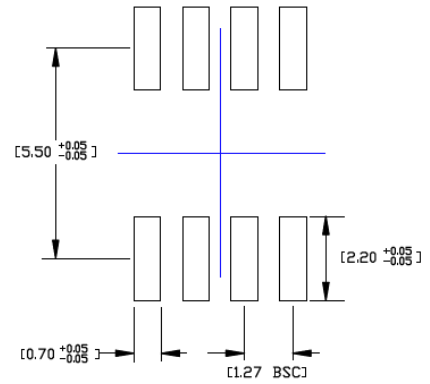

RECOMMENDED LAND PATTERN

NOTES:

1. DIMENSIONS ARE IN INCHES[MM].
2. CONTROLLING DIMENSION: INCHES.
3. DIMENSION DOES NOT INCLUDE MOLD FLASH OR PROTRUSIONS, EITHER OF WHICH SHALL NOT EXCEED 0.010[0.25] PER SIDE.

Note: For the most current package drawings, please see the Microchip Packaging Specification located at <http://www.microchip.com/packaging>.

MIC3203/MIC3203-1

NOTES:

APPENDIX A: REVISION HISTORY

Revision A (November 2019)

- Converted Micrel document MIC3203/MIC3203-1 to Microchip data sheet template DS20006250A.
- Minor grammatical text changes throughout.
- Updated minimum value for EN Logic Level High in [Electrical Characteristics](#) table.
- Evaluation Board Schematic and BOM sections from original data sheet moved to the part's Evaluation Board User's Guide.

MIC3203/MIC3203-1

NOTES:

PRODUCT IDENTIFICATION SYSTEM

To order or obtain information, e.g., on pricing or delivery, contact your local Microchip representative or sales office.

<u>Device</u>	<u>-X</u>	<u>X</u>	<u>X</u>	<u>-XX</u>
Part No.	Dither	Junction Temp. Range	Package	Media Type
Device:	MIC3203:	High-Brightness LED Driver Controller with High-Side Current Sense		
Dither:	<blank>=	Enabled		
	1 =	Disabled		
Junction Temperature Range:	Y =	-40°C to +125°C, RoHS-Compliant		
Package:	M =	8-Lead SOIC		
Media Type:	<blank>=	95/Tube		
	TR =	2,500/Reel		
Examples:				
a) MIC3203YM: MIC3203, Dither Enabled, -40°C to +125°C Temperature Range, 8-Lead SOIC, 95/Tube				
b) MIC3203YM-TR: MIC3203, Dither Enabled, -40°C to +125°C Temperature Range, 8-Lead SOIC, 2,500/Reel				
c) MIC3203-1YM: MIC3203, Dither Disabled, -40°C to +125°C Temperature Range, 8-Lead SOIC, 95/Tube				
d) MIC3203-1YM-TR: MIC3203, Dither Disabled, -40°C to +125°C Temperature Range, 8-Lead SOIC, 2,500/Reel				
Note 1: Tape and Reel identifier only appears in the catalog part number description. This identifier is used for ordering purposes and is not printed on the device package. Check with your Microchip Sales Office for package availability with the Tape and Reel option.				

MIC3203/MIC3203-1

NOTES:

Note the following details of the code protection feature on Microchip devices:

- Microchip products meet the specification contained in their particular Microchip Data Sheet.
- Microchip believes that its family of products is one of the most secure families of its kind on the market today, when used in the intended manner and under normal conditions.
- There are dishonest and possibly illegal methods used to breach the code protection feature. All of these methods, to our knowledge, require using the Microchip products in a manner outside the operating specifications contained in Microchip's Data Sheets. Most likely, the person doing so is engaged in theft of intellectual property.
- Microchip is willing to work with the customer who is concerned about the integrity of their code.
- Neither Microchip nor any other semiconductor manufacturer can guarantee the security of their code. Code protection does not mean that we are guaranteeing the product as “unbreakable.”

Code protection is constantly evolving. We at Microchip are committed to continuously improving the code protection features of our products. Attempts to break Microchip's code protection feature may be a violation of the Digital Millennium Copyright Act. If such acts allow unauthorized access to your software or other copyrighted work, you may have a right to sue for relief under that Act.

Information contained in this publication regarding device applications and the like is provided only for your convenience and may be superseded by updates. It is your responsibility to ensure that your application meets with your specifications. MICROCHIP MAKES NO REPRESENTATIONS OR WARRANTIES OF ANY KIND WHETHER EXPRESS OR IMPLIED, WRITTEN OR ORAL, STATUTORY OR OTHERWISE, RELATED TO THE INFORMATION, INCLUDING BUT NOT LIMITED TO ITS CONDITION, QUALITY, PERFORMANCE, MERCHANTABILITY OR FITNESS FOR PURPOSE. Microchip disclaims all liability arising from this information and its use. Use of Microchip devices in life support and/or safety applications is entirely at the buyer's risk, and the buyer agrees to defend, indemnify and hold harmless Microchip from any and all damages, claims, suits, or expenses resulting from such use. No licenses are conveyed, implicitly or otherwise, under any Microchip intellectual property rights unless otherwise stated.

Trademarks

The Microchip name and logo, the Microchip logo, Adaptec, AnyRate, AVR, AVR logo, AVR Freaks, BesTime, BitCloud, chipKIT, chipKIT logo, CryptoMemory, CryptoRF, dsPIC, FlashFlex, flexPWR, HELDO, IGLOO, JukeBlox, KeeLoq, Klear, LANCheck, LinkMD, maXStylus, maXTouch, MediaLB, megaAVR, Microsemi, Microsemi logo, MOST, MOST logo, MPLAB, OptoLyzer, PackeTime, PIC, picoPower, PICSTART, PIC32 logo, PolarFire, Prochip Designer, QTouch, SAM-BA, SenGenuity, SpyNIC, SST, SST Logo, SuperFlash, Symmetricom, SyncServer, Tachyon, TempTrackr, TimeSource, tinyAVR, UNI/O, Vectron, and XMEGA are registered trademarks of Microchip Technology Incorporated in the U.S.A. and other countries.

APT, ClockWorks, The Embedded Control Solutions Company, EtherSynch, FlashTec, Hyper Speed Control, HyperLight Load, IntelliMOS, Libero, motorBench, mTouch, Powermite 3, Precision Edge, ProASIC, ProASIC Plus, ProASIC Plus logo, Quiet-Wire, SmartFusion, SyncWorld, Temux, TimeCesium, TimeHub, TimePictra, TimeProvider, Vite, WinPath, and ZL are registered trademarks of Microchip Technology Incorporated in the U.S.A.

Adjacent Key Suppression, AKS, Analog-for-the-Digital Age, Any Capacitor, AnyIn, AnyOut, BlueSky, BodyCom, CodeGuard, CryptoAuthentication, CryptoAutomotive, CryptoCompanion, CryptoController, dsPICDEM, dsPICDEM.net, Dynamic Average Matching, DAM, ECAN, EtherGREEN, In-Circuit Serial Programming, ICSP, INICnet, Inter-Chip Connectivity, JitterBlocker, KlearNet, KlearNet logo, memBrain, Mindi, MiWi, MPASM, MPF, MPLAB Certified logo, MPLIB, MPLINK, MultiTRAK, NetDetach, Omniscient Code Generation, PICDEM, PICDEM.net, PICKit, PICtail, PowerSmart, PureSilicon, QMatrix, REAL ICE, Ripple Blocker, SAM-ICE, Serial Quad I/O, SMART-I.S., SQI, SuperSwitcher, SuperSwitcher II, Total Endurance, TSHARC, USBCheck, VariSense, ViewSpan, WiperLock, Wireless DNA, and ZENA are trademarks of Microchip Technology Incorporated in the U.S.A. and other countries.

SQTP is a service mark of Microchip Technology Incorporated in the U.S.A.

The Adaptec logo, Frequency on Demand, Silicon Storage Technology, and Symmcom are registered trademarks of Microchip Technology Inc. in other countries.

GestIC is a registered trademark of Microchip Technology Germany II GmbH & Co. KG, a subsidiary of Microchip Technology Inc., in other countries.

All other trademarks mentioned herein are property of their respective companies.

© 2019, Microchip Technology Incorporated, All Rights Reserved.

ISBN: 978-1-5224-5258-4

For information regarding Microchip's Quality Management Systems, please visit www.microchip.com/quality.



MICROCHIP

Worldwide Sales and Service

AMERICAS

Corporate Office
2355 West Chandler Blvd.
Chandler, AZ 85224-6199
Tel: 480-792-7200
Fax: 480-792-7277
Technical Support:
<http://www.microchip.com/support>
Web Address:
www.microchip.com

Atlanta

Duluth, GA
Tel: 678-957-9614
Fax: 678-957-1455

Austin, TX

Tel: 512-257-3370

Boston

Westborough, MA
Tel: 774-760-0087
Fax: 774-760-0088

Chicago

Itasca, IL
Tel: 630-285-0071
Fax: 630-285-0075

Dallas

Addison, TX
Tel: 972-818-7423
Fax: 972-818-2924

Detroit

Novi, MI
Tel: 248-848-4000

Houston, TX

Tel: 281-894-5983

Indianapolis

Noblesville, IN
Tel: 317-773-8323
Fax: 317-773-5453
Tel: 317-536-2380

Los Angeles

Mission Viejo, CA
Tel: 949-462-9523
Fax: 949-462-9608
Tel: 951-273-7800

Raleigh, NC

Tel: 919-844-7510

New York, NY

Tel: 631-435-6000

San Jose, CA

Tel: 408-735-9110
Tel: 408-436-4270

Canada - Toronto

Tel: 905-695-1980
Fax: 905-695-2078

ASIA/PACIFIC

Australia - Sydney
Tel: 61-2-9868-6733

China - Beijing
Tel: 86-10-8569-7000

China - Chengdu
Tel: 86-28-8665-5511

China - Chongqing
Tel: 86-23-8980-9588

China - Dongguan
Tel: 86-769-8702-9880

China - Guangzhou
Tel: 86-20-8755-8029

China - Hangzhou
Tel: 86-571-8792-8115

China - Hong Kong SAR
Tel: 852-2943-5100

China - Nanjing
Tel: 86-25-8473-2460

China - Qingdao
Tel: 86-532-8502-7355

China - Shanghai
Tel: 86-21-3326-8000

China - Shenyang
Tel: 86-24-2334-2829

China - Shenzhen
Tel: 86-755-8864-2200

China - Suzhou
Tel: 86-186-6233-1526

China - Wuhan
Tel: 86-27-5980-5300

China - Xian
Tel: 86-29-8833-7252

China - Xiamen
Tel: 86-592-2388138

China - Zhuhai
Tel: 86-756-3210040

ASIA/PACIFIC

India - Bangalore
Tel: 91-80-3090-4444

India - New Delhi
Tel: 91-11-4160-8631

India - Pune
Tel: 91-20-4121-0141

Japan - Osaka
Tel: 81-6-6152-7160

Japan - Tokyo
Tel: 81-3-6880-3770

Korea - Daegu
Tel: 82-53-744-4301

Korea - Seoul
Tel: 82-2-554-7200

Malaysia - Kuala Lumpur
Tel: 60-3-7651-7906

Malaysia - Penang
Tel: 60-4-227-8870

Philippines - Manila
Tel: 63-2-634-9065

Singapore
Tel: 65-6334-8870

Taiwan - Hsin Chu
Tel: 886-3-577-8366

Taiwan - Kaohsiung
Tel: 886-7-213-7830

Taiwan - Taipei
Tel: 886-2-2508-8600

Thailand - Bangkok
Tel: 66-2-694-1351

Vietnam - Ho Chi Minh
Tel: 84-28-5448-2100

EUROPE

Austria - Wels
Tel: 43-7242-2244-39
Fax: 43-7242-2244-393

Denmark - Copenhagen
Tel: 45-4450-2828
Fax: 45-4485-2829

Finland - Espoo
Tel: 358-9-4520-820

France - Paris
Tel: 33-1-69-53-63-20
Fax: 33-1-69-30-90-79

Germany - Garching
Tel: 49-8931-9700

Germany - Haan
Tel: 49-2129-3766400

Germany - Heilbronn
Tel: 49-7131-72400

Germany - Karlsruhe
Tel: 49-721-625370

Germany - Munich
Tel: 49-89-627-144-0
Fax: 49-89-627-144-44

Germany - Rosenheim
Tel: 49-8031-354-560

Israel - Ra'anana
Tel: 972-9-744-7705

Italy - Milan
Tel: 39-0331-742611
Fax: 39-0331-466781

Italy - Padova
Tel: 39-049-7625286

Netherlands - Drunen
Tel: 31-416-690399
Fax: 31-416-690340

Norway - Trondheim
Tel: 47-7288-4388

Poland - Warsaw
Tel: 48-22-3325737

Romania - Bucharest
Tel: 40-21-407-87-50

Spain - Madrid
Tel: 34-91-708-08-90
Fax: 34-91-708-08-91

Sweden - Gothenberg
Tel: 46-31-704-60-40

Sweden - Stockholm
Tel: 46-8-5090-4654

UK - Wokingham
Tel: 44-118-921-5800
Fax: 44-118-921-5820