

TLE4999I3

Programmable Dual Channel Linear Hall Sensor with PSI5 Interface



ISO26262
compliant

Features

- Two highly accurate redundant Hall measurement channels (main and sub) integrated on one chip.
- Developed compliant to **ISO26262** for safety requirements rated up to **ASIL D**.
- PSI5 v2.1-compatible interface in synchronous mode with high speed P10P-400/4H protocol.
- Bi-directional interface for programming via fast SICI interface.
- 13bit output signals, protected by CRC and rolling counters.
- Digital temperature and stress compensation.
- 3-pin leaded package for mounting in PCB-less modules.
- Operating junction temperature range -40°C to 150°C.
- Main and sub channel programmable independently in EEPROM.
- 16bit user-configurable ID in EEPROM.
- Supply voltage 5.5 to 7 V.



PRO-SIL™ Features

- Safety Manual and Safety Analysis Summary Report.

Potential applications

- Suited for safety applications such as steering torque sensing, pedal position and throttle position.
- Robust replacement of potentiometers: No mechanical abrasion, resistant to humidity, temperature, pollution and vibration.
- Linear and angular position sensing in automotive and industrial applications with highest accuracy requirements.

Product validation

Qualified for automotive applications. Product validation according to AEC-Q100.

Description

The TLE4999I3 is a dual channel linear Hall sensor with a synchronous digital PSI5-compatible interface. It is compliant to **ISO26262**, supporting safety requirements on system level rated up to **ASIL D**.

The TLE4999I3 features two highly accurate Hall measurement channels on one chip. A plausibility check of the two redundant channels on system level enables a high diagnostic coverage.

Highest accuracy over a wide temperature range and lifetime is achieved by an integrated digital temperature- and stress-compensation.

Table 1 **Ordering Information**

Product Name	Marking	Ordering Code	Package
TLE4999I3	4999I3	SP001689862	PG-SSO-3-12

Table of Contents

1	Block Diagram	4
2	Pin-Out	5
3	Functional Description	6
4	Application Circuit	6
5	Maximum Ratings	7
6	Operating range	8
7	Electrical, Magnetic and Output Parameters	9
8	Digital Current Interface	11
8.1	Manchester Encoding	11
8.2	Communication Protocol	12
8.3	Digital Interface timing	12
9	Configuration and Calibration Parameters	13
10	PG-SSO-3-12 Package Outline	15
11	Revision History	16

Block Diagram

1 Block Diagram

Figure 1 shows a simplified block diagram of the TLE4999I3.

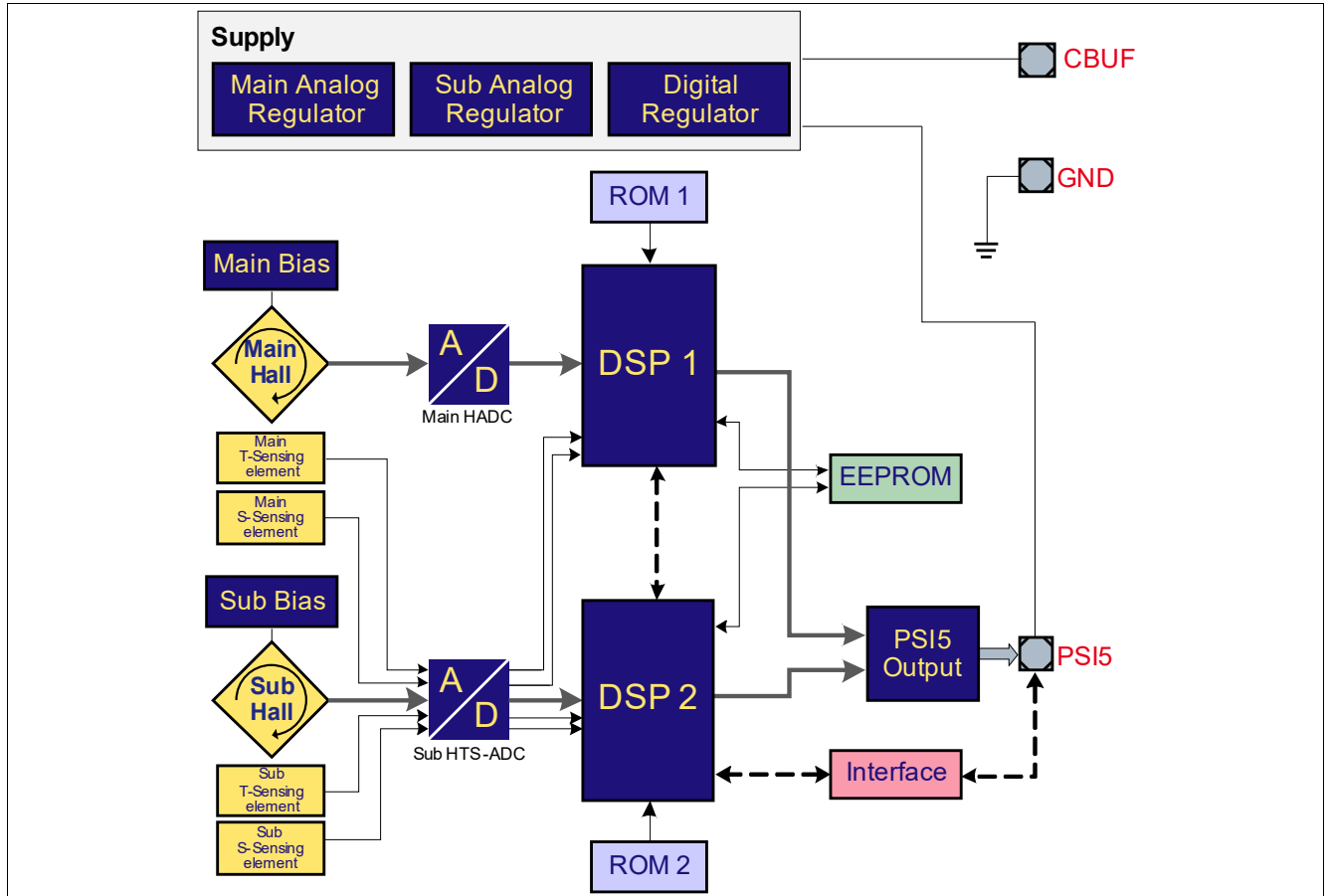

Figure 1 TLE4999I3 Simplified Block Diagram

Pin-Out

2 Pin-Out

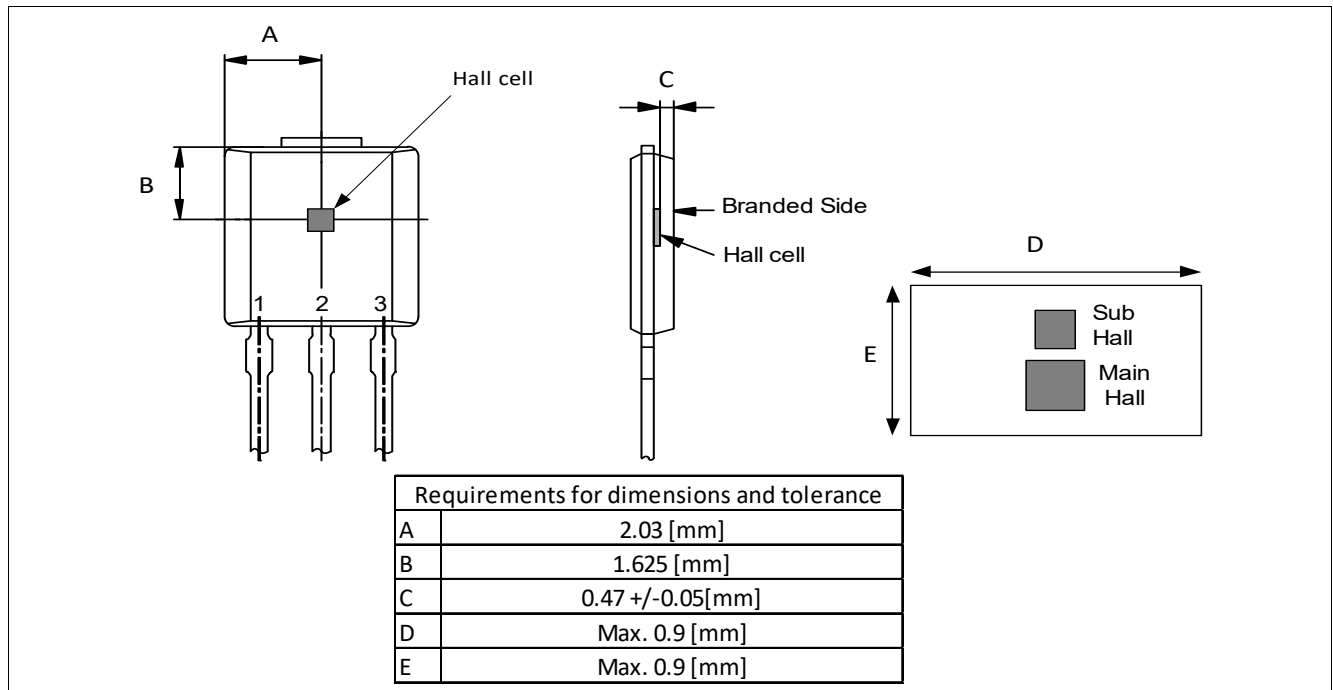

Figure 2 TLE4999I3 Pin Configuration and Hall Cell Location

Table 2 TLE4999I3 Pin Definitions and Functions

Pin No.	Symbol	Function
1	<i>CBUF</i>	Buffer capacitor
2	<i>GND</i>	Ground
3	<i>PSI5</i>	PSI5 output/ supply voltage

Functional Description

3 Functional Description

The TLE4999I3 is a dual channel linear Hall sensor designed to meet the requirements of highly accurate steering torque measurement applications. The sensor provides a digital Manchester-encoded current modulation signal that is compatible to PSI5 v2.1 on the PSI5 pin. Configuration parameters can be programmed after assembly of the sensor in a module in an end-of-line calibration procedure using the two-wire SICI (serial inspection and configuration interface).

The two measurement channels have separate analog supply domains controlled by the main and sub analog regulators. These regulators feed separate biasing units for the main and sub Hall sensor elements. The analog signal of the main Hall probe is fed into an analog-digital converter (main HADC), and is then processed in a digital signal processing unit (DSP1). A multiplexed second analog-digital converter (sub HTS-ADC) is used to convert analog signals from the main and sub temperature and stress sensing elements, and the sub Hall probe. The sub Hall, sub temperature and sub stress signals are fed into the second digital signal processing unit (DSP2). The main temperature and main stress signals are fed into DSP1. Each DSP uses its corresponding temperature, stress and Hall signal, together with compensation parameters stored in the EEPROM to calculate a Hall measurement value that is compensated for stress and temperature drift effects.

A high speed Manchester-encoded protocol is generated from the data of the two DSPs in the PSI5 output stage. The protocol is transmitted in synchronous mode, triggered by a synchronization pulse on the PSI5 pin.

4 Application Circuit

Figure 3 shows the recommended application circuit of the TLE4999I3.

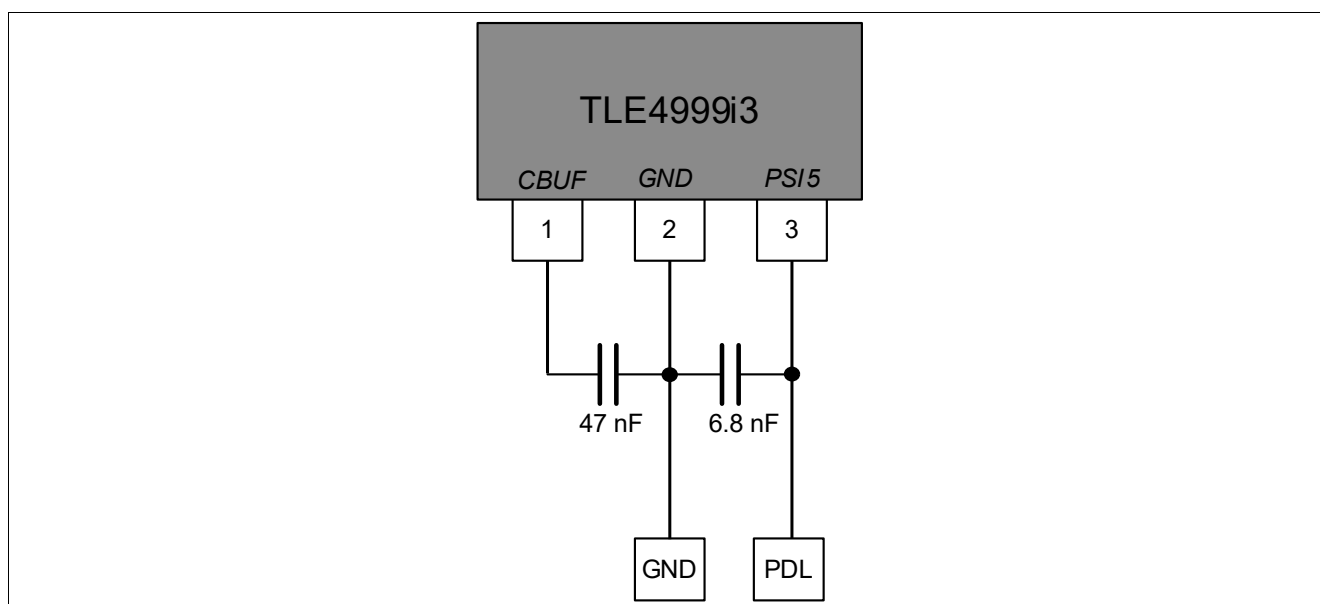

Figure 3 TLE4999I3 Recommended Application Circuit

Programming of the sensor is done via the SICI interface on the PDL line.

Note: Infineon recommends that the capacitors are placed close to the sensor

Maximum Ratings

5 Maximum Ratings

Table 3 Absolute Maximum Ratings

Parameter	Symbol	Limit Values		Unit	Notes
		Min.	Max.		
Non-operating temperature	T_{NOL}	-40	150	°C	max. 4400 hours at 150°C ¹⁾ (not additive)
Junction temperature	T_J	-40	175	°C	max. 96 hours at 175°C ¹⁾ (not additive)
Voltage supply maximum ratings	$V_{DD, max}$	-21.5	21.5	V	max. 24 h for -40°C to 30°C T_J max. 10 min for 30°C to 80°C T_J max. 30 s for 80°C to 125°C T_J max. 15 s above 125°C T_J
Supply current in overvoltage	$I_{DD, ov}$	-	45	mA	time limitation for V_{DD} applies
Supply current in reverse voltage	$I_{DD, rev}$	-75	-	mA	time limitation for V_{DD} applies
Magnetic flux density	B_{max}	-	1000	mT	
ESD immunity	V_{HBM}	-	±4	kV	The product can withstand the specified maximum Electro-Static Discharge voltage according to HBM ESD test standard ²⁾
	V_{CDM}	-	±0.75	kV	The product can withstand the specified maximum Electro-Static Discharge voltage according to CDM ESD test standard ³⁾

1) Maximum exposure time at other junction temperatures shall be calculated using the Arrhenius-model

2) Human Body Model (HBM) according to ANSI/ESDA/JEDEC JS-001

3) Charged Device Model (CDM) according to ANSI/ESDA/JEDEC JS-002

Note: Any stress exceeding the values listed in **Table 3** may cause permanent damage to the device. The values given are stress ratings only and functional operation of the device at these conditions is not implied. Exposure to absolute maximum rating conditions for extended periods may affect device reliability.

Operating Range

6 Operating Range

The following operating conditions must not be exceeded in order to ensure correct operation of the TLE4999I3. All parameters specified in the next sections refer to these operating conditions unless otherwise indicated.

Table 4 Operating Range

Parameter	Symbol	Values			Unit	Notes
		Min.	Typ.	Max.		
Supply voltage	$V_{DD,cm}$	5.5	-	7	V	
		$V_{DD,pon}$	-	5.5	V	Extended range ¹⁾
		7	-	16.5	V	Extended range ²⁾
Sync pulse voltage	V_{Sync}	$V_{DD,cm} + 2.5$	-	16.5 - $V_{DD,cm}$	V	
Operating junction temperature	T_J	-40	-	150	°C	max.4400 hours at 150°C ³⁾ (not additive)
Magnetic flux density	B	-	-	25	mT	Maximum magnetic measurement range: -25 to 25 mT ⁴⁾

- 1) No performance degradation in undervoltage between 5.5 V and actual supply undervoltage reset level
- 2) No performance degradation in overvoltage between 7 V and actual supply overvoltage shutdown level
- 3) Maximum exposure time at other junction temperatures shall be calculated using the Arrhenius-model
- 4) At room temperature

*Note: In addition to adhering to **Table 4**, the specifications of the PSI5 standard Rev.2.1 regarding wiring and transceiver characteristics have to be obeyed to ensure accurate and reliable operation.*

Electrical, Magnetic and Output Parameters

7 Electrical, Magnetic and Output Parameters

All specifications are valid over the full temperature range and over lifetime.

Table 5 Electrical Characteristics

Parameter	Symbol	Values			Unit	Notes
		Min.	Typ.	Max.		
Supply current	I_{DD}	4	–	14	mA	
Communication sink current	ΔI	22	26	30	mA	
Power-on time	t_{pon}	–	–	5	ms	
Supply undervoltage reset level	$V_{DD, pon}$	3.1	–	3.9	V	Equal or below this level no PSI5 protocol is transmitted
Supply undervoltage release level	$V_{DD, pon rel}$	3.25	–	4.5	V	Above or equal to this value the PSI5 protocol is transmitted again
Supply overvoltage shutdown level	$V_{DD, ov}$	17.5	–	21.5	V	Equal or above this level no PSI5 protocol shall be transmitted
Supply overvoltage release level	$V_{DD, ov rel}$	16	–	19	V	Below or equal to this value the PSI5 protocol shall be transmitted again
Reset hysteresis	$V_{DD, pon hyst}$	100	–	300	mV	
Interface timing variation	Δf_{PSI5}	-5	–	5	%	in % of nominal PSI5 timing

Main and sub channels of the TLE4999I3 provide highly accurate 13bit magnetic field signals. The output characteristics of the two channels are specified in [Table 6](#), [Table 7](#), and [Table 8](#).

Table 6 Magnetic and output characteristics of main channel

Parameter	Symbol	Values			Unit	Notes
		Min.	Typ.	Max.		
Magnetic offset drift main ¹⁾	ΔB_{OS_Main}	-100	–	100	μT	
Output noise (RMS)	OUT_{Noise_Main}	–	–	4	LSB_{13}	at LP-Filter setting 8, range 25 mT, gain 1.0 (scales linearly with gain), $ B =0mT$

1) Drift over temperature and lifetime

Electrical, Magnetic and Output Parameters

Table 7 Magnetic and output characteristics of sub channel

Parameter	Symbol	Values			Unit	Notes
		Min.	Typ.	Max.		
Magnetic offset drift sub ¹⁾	ΔB_{OS_Sub}	-200	-	200	μT	
Output noise (RMS)	OUT_{Noise_Sub}	-	-	8	LSB_{13}	at LP-Filter setting 8, range 25 mT, gain 1.0 (scales linearly with gain), $ B =0mT$

1) Drift over temperature and lifetime

Table 8 Common magnetic and output characteristics for main and sub channel

Parameter	Symbol	Values			Unit	Notes
		Min.	Typ.	Max.		
Magnetic sensitivity drift ¹⁾	ΔS_{Main}	-2	-	2	%	
Magnetic initial offset - Main and Sub channel	ΔB_{OS}	-300	-	300	μT	at 0 h, 25 °C
Magnetic hysteresis	B_{Hys}	-	-	20	μT	at range 25 mT, gain=1.0, 25°C
Integral non-linearity	INL	-24	-	24	LSB_{13}	at range 25 mT, gain 1.0 (scales linearly with gain)
Signal latency ²⁾	$t_{latency}$	-	-	500	μs	not including interface transmission time. for LP-Filter setting 8

1) Drift over temperature and lifetime

2) Defined as phase shift of 100 Hz sine signal

Digital Current Interface

Figure 4 shows the output characteristics of the sensor’s main and sub channel in the default setting. The output characteristics can be changed by reconfiguring the zero point, gain and clamping ranges for main and sub channel (see **Chapter 9**).

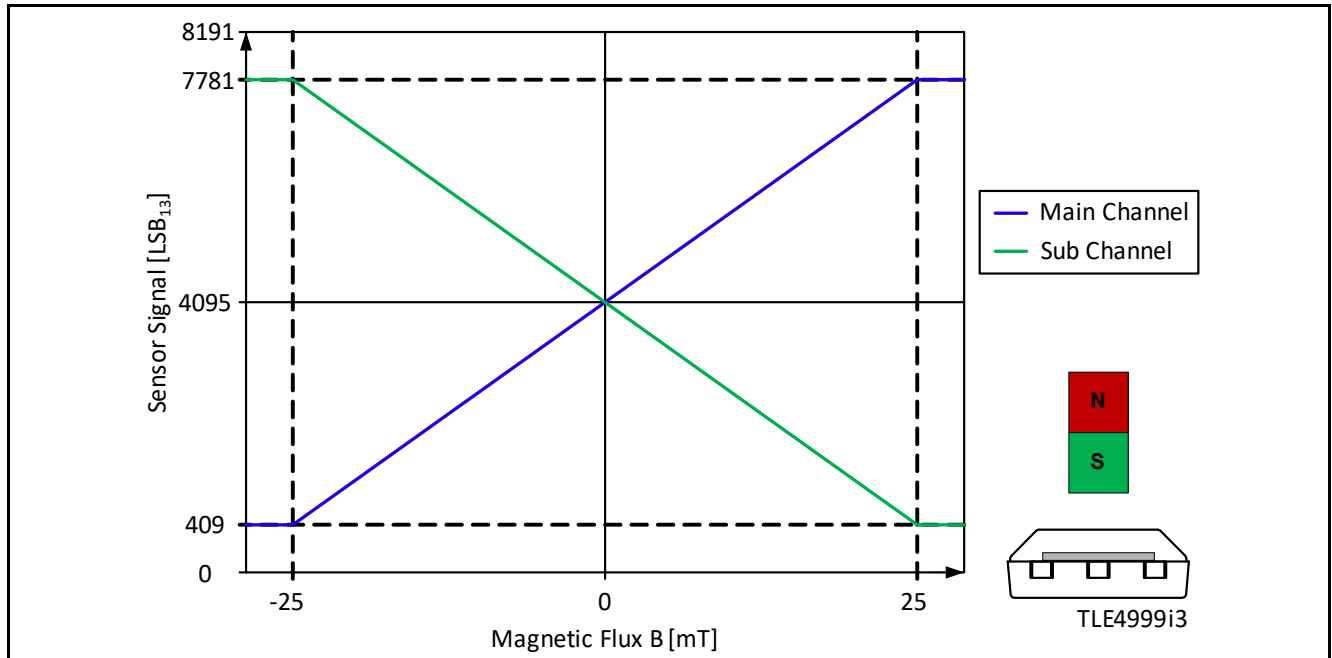

Figure 4 TLE4999I3 Default Output Characteristic

8 Digital Current Interface

The TLE4999I3 has a digital current interface in synchronous mode, which is compatible to PSI5 Rev2.1.

8.1 Manchester Encoding

The digital interface uses Manchester encoding for data transmission. In the middle of each bit there is a rising or falling edge, which is interpreted as a logical “0” or “1” by the receiver (see **Figure 5**). This allows for a synchronisation of the receiver to the sensor and efficient bit-error detection.

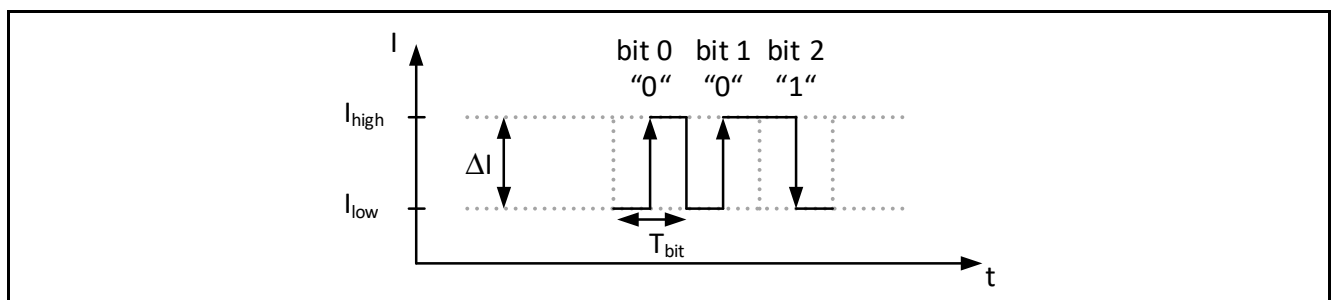

Figure 5 Manchester Encoding Scheme

Digital Current Interface

8.2 Communication Protocol

The communication frame format of the TLE4999I3 is P10P-400/4H, with a bit rate of 189 kbps. After receiving a valid sync pulse, the sensor transmits four 10bit data messages, which contain the two measurement values of the main and sub channel, message counter and CRC checksum. Each message has two start bits and one parity bit.

The digital protocol has one common 7bit checksum that is calculated from all four messages.

	S1	S2	D0	D1	D2	D3	D4	D5	D6	D7	D8	D9	P
1st	S	S	Main (upper 9 bits)									RE	P
			[4]	[5]	[6]	[7]	[8]	[9]	[10]	[11]	[12]		
2nd	S	S	Sub (upper 9 bits)									RE	P
			[4]	[5]	[6]	[7]	[8]	[9]	[10]	[11]	[12]		
3rd	S	S	ID	Main (lower 4 bits)				Sub (lower 4 bits)				RE	P
			[0]	[0]	[1]	[2]	[3]	[0]	[1]	[2]	[3]		
4th	S	S	Counter		7bit CRC							RE	P
			[0]	[1]	[0]	[1]	[2]	[3]	[4]	[5]	[6]		

Figure 6 Communication Protocol of the TLE4999I3.

- Start bits (S1 & S2) : The PSI5 standard requires every frame to begin with two start bits that have the logical value “0”.
- Main (9 + 4 bits): Main channel measurement data (bit 0 = LSB, bit 12 = MSB).
- Sub (9 + 4 bits): Sub channel measurement data (bit 0 = LSB, bit 12 = MSB).
- Counter: rolling message counter: 00 -> 01 -> 10 -> 11 -> 00 -> ...
- ID: Programmable sensor ID bit to identify sensors in module. Value configurable in EEPROM register.
- RE: Reserved bit. D9 has the same value as D5. This rule provides compatibility to the “data range” specification of the PSI5 standard
- CRC: 7bit Checksum
- P: Parity bit (even)

The 7bit Checksum is calculated using the generator polynomial x^7+x^3+1 and the seed value 1010101_B . The checksum is calculated from bits D0 to D9 of messages 1 to 3 plus bits D0 and D1 of message 4.

Table 9 Data for CRC calculation

Seed (7 bit)	Frame 1 (10 bit)	Frame 2 (10 bit)	Frame 3 (10 bit)	Frame 4 (2 bit)	Append zeros
1010101_B	bits D0-D9	bits D0-D9	bits D0-D9	bits D0-D1	0000000_B

Attention: The RE bit of the 4th data frame is not included in the 7bit Checksum.

8.3 Digital Interface timing

After the sync pulse is received by the TLE4999I3, it sends the first data frame after the response time t_{pD} , which is measured from the beginning of the sync pulse (see **Figure 7**). The TLE4999I3 outputs four data frames with a gap of t_{gap} between the frames.

Configuration and Calibration Parameters

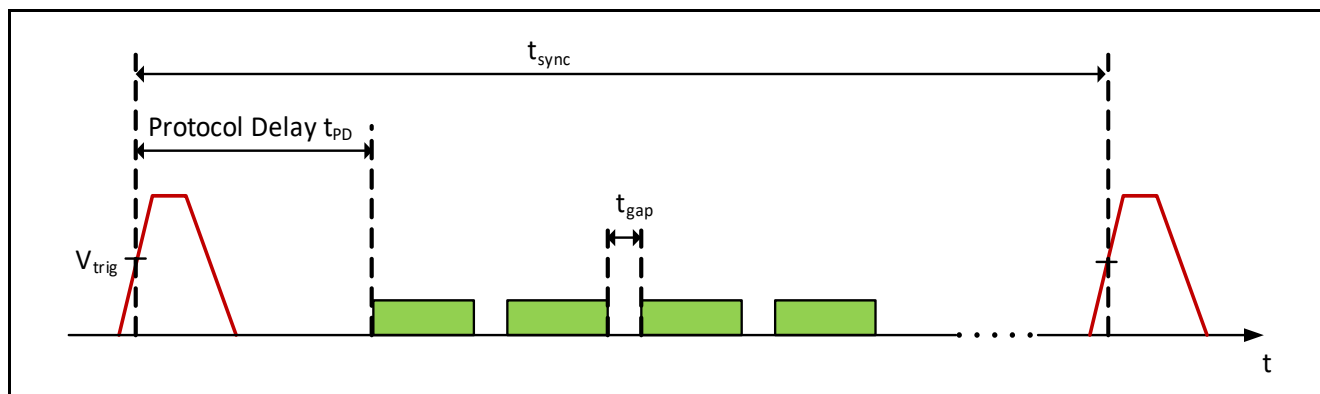

Figure 7 Digital Interface Timing

Table 10 Interface Timing characteristics of TLE4999I3

Parameter	Symbol	Values			Unit	Notes
		Min.	Typ.	Max.		
Sync period	t_{sync}	400	-	-	μs	
Data frame gap	t_{gap}	10	-	11.2	μs	

Note: Protocol delay and Protocol rise and fall times are configurable, the limits are defined in [Table 12](#)

9 Configuration and Calibration Parameters

The TLE4999I3 has several configurable parameters which are stored in the EEPROM. These parameters affect the interface timing parameters. [Table 11](#) gives an overview of the magnetic measurement parameters, which can be configured separately for main and sub channel. [Table 12](#) shows the PSI5 interface parameters.

Table 11 TLE4999I3 Magnetic Measurement Parameters for Main and Sub Channel

Parameter	Setting range	Note
Magnetic range	25 mT (default) 12.5 mT	
Gain	-5.43...5.42	Gain value of +1.0 corresponds to typical 147.5 LSB ₁₃ /mT sensitivity in 25 mT range.
Zero point	0 LSB ₁₃ ... 8191 LSB ₁₃	
Clamping low level	0 LSB ₁₃ ... 8191 LSB ₁₃	For default output clamping settings, see Figure 4 .
Clamping high level	0 LSB ₁₃ ... 8191 LSB ₁₃	

Configuration and Calibration Parameters

Table 11 TLE4999I3 Magnetic Measurement Parameters for Main and Sub Channel

Parameter	Setting range	Note
Bandwidth ¹⁾	0: Off ²⁾ 1: 80Hz 2: 160 Hz 3: 200 Hz 4: 240 Hz 5: 320 Hz 6: 400 Hz 7: 470 Hz 8: 500 Hz (default) 9: 650 Hz 10: 870 Hz 11: 980 Hz 12: 1070 Hz 13: 1270 Hz 14: 1380 Hz 15: 1530 Hz	Low-pass filter cut-off (-3 dB) frequency
1 st order temperature coefficient TC ₁	-2400 ppm/°C ... 5400 ppm/°C	Second order user configurable temperature compensation
2 nd order temperature coefficient TC ₂	-30 ppm/°C ² ... 30 ppm/°C ²	
Reference Temperature T ₀	0°C ... 127°C	

- 1) Subject to oscillator variation ±5%.
2) Set programmable low pass filter off, inherent filter of ADC stays on

Table 12 TLE4999I3 PSI5 Interface Parameters

Parameter	Symbol	Values			Unit	Notes
		Min.	Typ.	Max.		
Protocol delay ¹⁾	t _{PD}	44	-	299	μs	configurable via EEPROM setting (see TLE4999i User Manual)
Protocol rise and fall times ¹⁾	t _{current slope}	0.33	-	1	μs	with recommended application circuit (see Figure 3); configurable via EEPROM setting (see TLE4999i User Manual)

- 1) Interface timing variation not included

10 PG-SSO-3-12 Package Outline

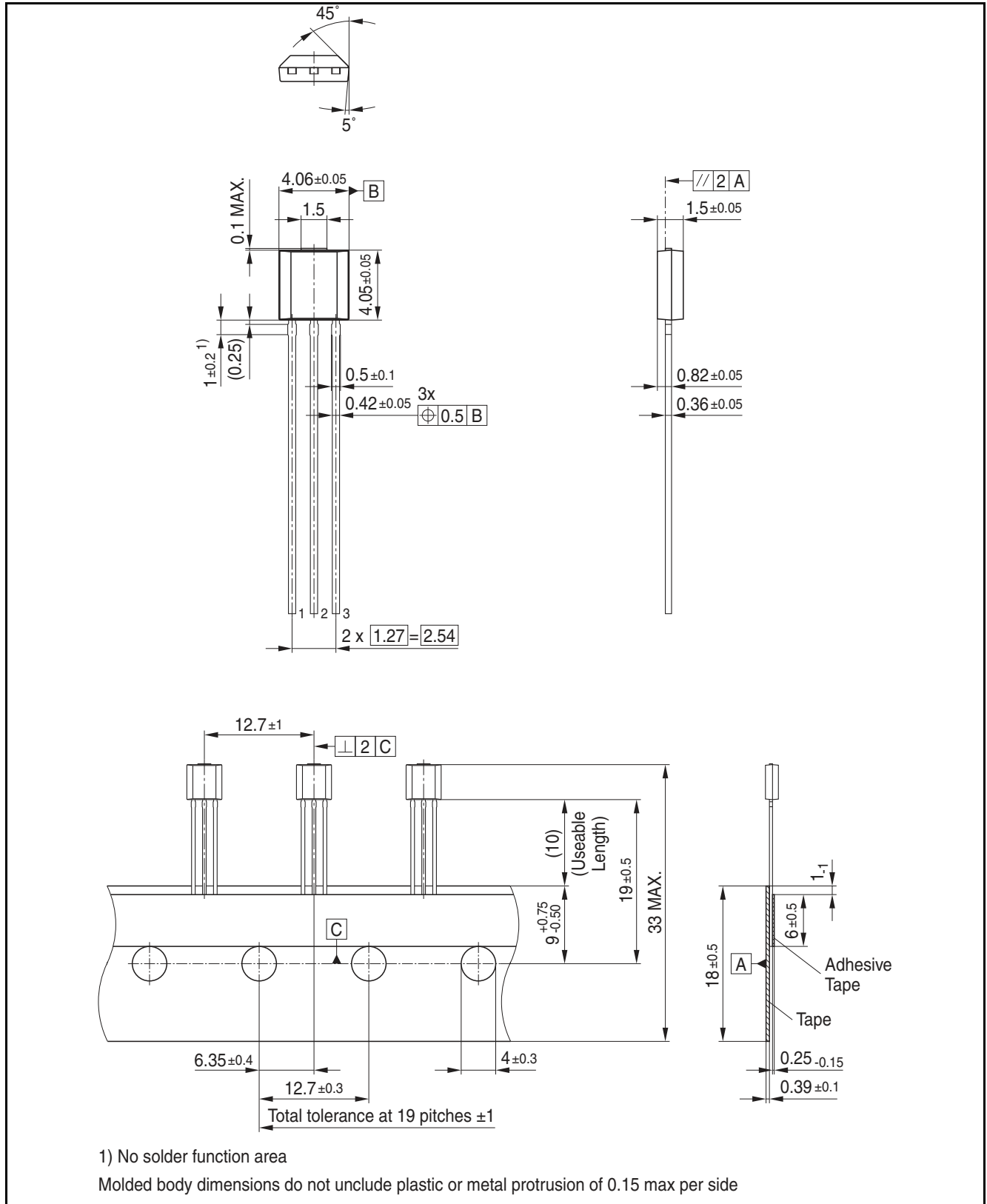

Figure 8 PG-SSO-3-12 Package Outline (values in mm)

Revision History

11 Revision History

Revision	Date	Changes
1.0	2018-07	Initial version

Terminology

A	
ADC	Analog to digital converter
C	
CBUF	Buffer capacitor
CRC	Cyclic redundancy check
D	
DSP	Digital Signal Processing unit
E	
ECC	Error correction code to protect EEPROM content
EEPROM (abbrev. EEP)	Electrically erasable and programmable read only memory - programmable memory for sensor calibration and configuration data
G	
GND	Ground - ground line of sensor
H	
HADC	Hall analog to digital converter
HTS-ADC	Hall, temperature, stress analog to digital converter
I	
ID	Identification
L	
LP-Filter	Low Pass Filter
LSB	Least significant bit
M	
MSB	Most significant bit
MVS	Margin voltage selector
O	
OUT	Current modulator output pin of the sensor
P	
PSI5	Peripheral Sensor Interface 5
PDL	Peripheral Data Line - combined supply and data input/output line of a PSI5 sensor
PWM	Pulse-Width-Modulation
R	
RMS	Root mean square
ROM	Read only memory
S	
SICI	Serial Inspection and Configuration Interface - Programming interface of the TLE4999I3
T	
TBD	To be defined

Trademarks

All referenced product or service names and trademarks are the property of their respective owners.

Edition 2018-07-18

Published by

Infineon Technologies AG

81726 Munich, Germany

© 2019 Infineon Technologies AG.

All Rights Reserved.

Do you have a question about any aspect of this document?

Email: erratum@infineon.com

Document reference

IMPORTANT NOTICE

The information given in this document shall in no event be regarded as a guarantee of conditions or characteristics ("Beschaffenhheitsgarantie").

With respect to any examples, hints or any typical values stated herein and/or any information regarding the application of the product, Infineon Technologies hereby disclaims any and all warranties and liabilities of any kind, including without limitation warranties of non-infringement of intellectual property rights of any third party.

In addition, any information given in this document is subject to customer's compliance with its obligations stated in this document and any applicable legal requirements, norms and standards concerning customer's products and any use of the product of Infineon Technologies in customer's applications.

The data contained in this document is exclusively intended for technically trained staff. It is the responsibility of customer's technical departments to evaluate the suitability of the product for the intended application and the completeness of the product information given in this document with respect to such application.

For further information on technology, delivery terms and conditions and prices, please contact the nearest Infineon Technologies Office (www.infineon.com).

WARNINGS

Due to technical requirements products may contain dangerous substances. For information on the types in question please contact your nearest Infineon Technologies office.

Except as otherwise explicitly approved by Infineon Technologies in a written document signed by authorized representatives of Infineon Technologies, Infineon Technologies' products may not be used in any applications where a failure of the product or any consequences of the use thereof can reasonably be expected to result in personal injury.