

85V Full-Bridge MOSFET Drivers with Adaptive Dead Time and Shoot-Through Protection

Features

- 5.5V to 16V Gate Drive Supply Voltage Range
- Advanced Adaptive Dead Time
- Intelligent Shoot-Through Protection
- MIC4606-1: Four Independent TTL Inputs
- MIC4606-2: Two PWM Inputs
- Enable Input for On/Off Control
- On-Chip Bootstrap Diodes
- Fast 35 ns Propagation Times
- Drives 1000 pF Load with 20 ns Rise and Fall Times
- Low Power Consumption: 235 μ A Total Quiescent Current
- Separate High-Side and Low-Side Undervoltage Protection
- -40°C to +125°C Junction Temperature Range

Applications

- Full-Bridge Motor Drives
- Power Inverters
- High-Voltage Step-Down Regulators
- Distributed Power Systems
- Stepper Motors

General Description

The MIC4606 is an 85V full-bridge MOSFET driver that features adaptive dead time and shoot-through protection. The adaptive dead-time circuitry actively monitors both sides of the full bridge to minimize the time between high-side and low-side MOSFET transitions, thus maximizing power efficiency. Anti-shoot-through circuitry prevents erroneous inputs and noise from turning both MOSFETs of each side of the bridge on at the same time.

The MIC4606 also offers a wide 5.5V to 16V operating supply range to maximize system efficiency. The low 5.5V operating voltage allows longer run times in battery-powered applications. Additionally, the MIC4606 device's adjustable gate drive sets the gate drive voltage to V_{DD} for optimal MOSFET $R_{DS(ON)}$, which minimizes power loss due to the MOSFET's $R_{DS(ON)}$.

The MIC4606-1 features four independent inputs while the MIC4606-2 utilizes two PWM inputs, one for each side of the H-bridge. The MIC4606-1 and MIC4606-2 are available in a 16-pin 4 mm x 4 mm QFN package, and a 16-pin 4 mm x 5 mm TSSOP package with an operating temperature range of -40°C to +125°C.

Typical Application Circuit

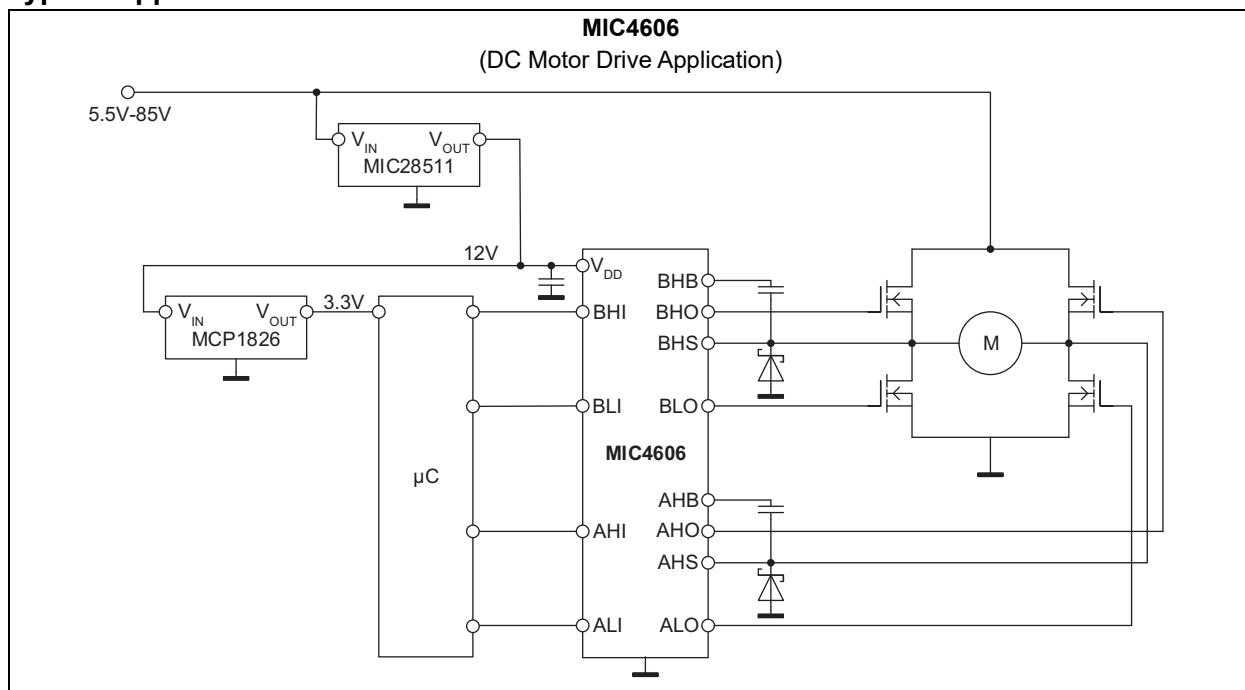

MIC4606

Package Types

MIC4606-1
16-Pin QFN
4 mm x 4 mm

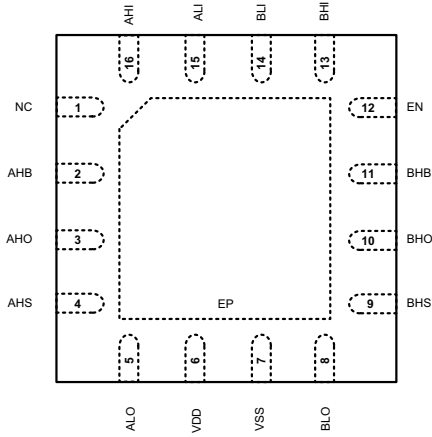

MIC4606-2
16-Pin QFN
4 mm x 4 mm

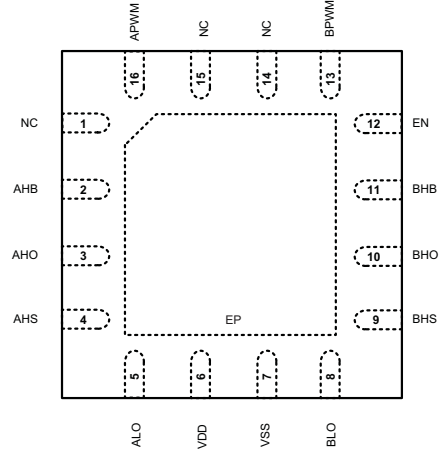

MIC4606-1
16-Pin TSSOP
4 mm x 5 mm

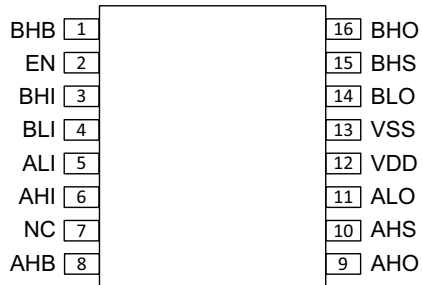

MIC4606-2
16-Pin TSSOP
4 mm x 5 mm

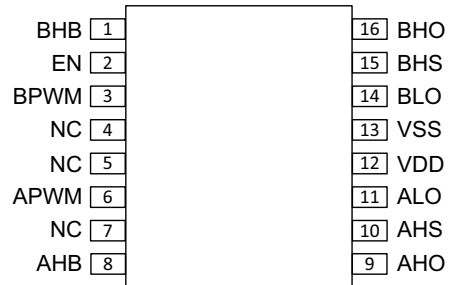

Note: See [Table 4-1](#) through [Table 4-4](#) for pin descriptions.

1.0 ELECTRICAL CHARACTERISTICS

Absolute Maximum Ratings† (Note 1)

Supply Voltage (V_{DD} , $V_{xHB} - V_{xHS}$)	-0.3V to +18V
Input Voltage (V_{xLI} , V_{xHI} , V_{EN})	-0.3V to $V_{DD} + 0.3V$
Voltage on xLO (V_{xLO})	-0.3V to $V_{DD} + 0.3V$
Voltage on xHO (V_{xHO})	$V_{HS} - 0.3V$ to $V_{HB} + 0.3V$
Voltage on xHS (Continuous)	-0.3V to 90V
Voltage on xHB	108V
Average Current in V_{DD} to HB Diode	100 mA
ESD Protection On All Pins (Note 2)	±1 kV HBM, ±200V MM

Operating Ratings††

Supply Voltage (V_{DD}) [decreasing V_{DD}]	+5.25V to +16V
Supply Voltage (V_{DD}) [increasing V_{DD}]	+5.5V to +16V
Enable Voltage (V_{EN})	0V to V_{DD}
Voltage on xHS	-0.3V to +85V
Voltage on xHS (repetitive transient < 1 μ s)	-1V to +90V
HS Slew Rate	50 V/ns
Voltage on xHB	V_{HS} to V_{DD}
and/or	$V_{DD} - 1V$ to $V_{DD} + 85V$

† Notice: Exceeding the absolute maximum ratings may damage the device.

†† Notice: The device is not ensured to function outside its operating ratings.

Note 1: "x" in front of a pin name refers to either A or B (e.g., xHI can be either AHI or BHI).

2: Devices are ESD-sensitive. Handling precautions are recommended. Human body model, 1.5 k Ω in series with 100 pF.

ELECTRICAL CHARACTERISTICS

Electrical Characteristics: Unless otherwise indicated: $V_{DD} = V_{xHB} = 12V$; $V_{EN} = 5V$; $V_{SS} = V_{xHS} = 0V$; No load on xLO or xHO; $T_A = +25^\circ C$. **Bold** values indicate $-40^\circ C \leq T_J \leq +125^\circ C$. (1,2)

Parameters	Sym.	Min.	Typ.	Max.	Units	Conditions
Supply Current						
V_{DD} Quiescent Current	I_{DD}	—	200	350	μA	$xLI = xHI = 0V$
V_{DD} Shutdown Current	I_{DDSH}	—	2.5	5	μA	EN = 0V with xHS = floating
		—	40	100		EN = 0V, xLI, xHI = 12V or 0V
V_{DD} Operating Current	I_{DDO}	—	0.35	0.5	mA	$f_S = 20$ kHz
Total xHB Quiescent Current	I_{HB}	—	35	75	μA	$xLI = xHI = 0V$ or $xLI = 0V$ and $xHI = 5V$
Total xHB Operating Current	I_{HBO}	—	30	400	μA	$f_S = 20$ kHz
xHB to V_{SS} Quiescent Current	I_{HBS}	—	0.5	5	μA	$V_{xHS} = V_{xHB} = 90V$
xHB to V_{SS} Operating Current	I_{HBSO}	—	3	10	μA	$f_S = 20$ kHz

Note 1: Specification for packaged product only.

2: "x" in front of a pin name refers to either A or B (e.g., xHI can be either AHI or BHI).

3: $V_{IL(MAX)}$ = maximum positive voltage applied to the input which will be accepted by the device as a logic low.

$V_{IH(MIN)}$ = minimum positive voltage applied to the input which will be accepted by the device as a logic high.

4: xLI/xHI mode with inputs non-overlapping, assumes xHS low before xLI goes high and xLO low before xHI goes high.

5: PWM mode (MIC4606-2) or LI/HI mode (MIC4606-1) with overlapping xLI/xHI inputs.

MIC4606

ELECTRICAL CHARACTERISTICS (CONTINUED)

Electrical Characteristics: Unless otherwise indicated: $V_{DD} = V_{xHB} = 12V$; $V_{EN} = 5V$; $V_{SS} = V_{xHS} = 0V$; No load on xLO or xHO; $T_A = +25^\circ C$. **Bold** values indicate $-40^\circ C \leq T_J \leq +125^\circ C$. (1,2)

Parameters	Sym.	Min.	Typ.	Max.	Units	Conditions
Input (TTL: xLI, xHI, EN) (Notes 2,3)						
Low-Level Input Voltage	V_{IL}	—	—	0.8	V	
High-Level Input Voltage	V_{IH}	2.2	—	—	V	
Input Voltage Hysteresis	V_{HYS}	—	0.1	—	V	
Input Pull-Down Resistance	R_I	100	300	500	k Ω	xHI/xLI inputs
		50	150	250	k Ω	xPWM inputs
Undervoltage Protection						
V_{DD} Falling Threshold	V_{DDR}	4.0	4.4	4.9	V	
V_{DD} Threshold Hysteresis	V_{DDH}	—	0.25	—	V	
xHB Falling Threshold	V_{HBR}	4.0	4.4	4.9	V	
xHB Threshold Hysteresis	V_{HBH}	—	0.25	—	V	
Bootstrap Diode						
Low-Current Forward Voltage	V_{DL}	—	0.4	0.70	V	$I_{VDD-xHB} = 100 \mu A$
High-Current Forward Voltage	V_{DH}	—	0.7	1.0	V	$I_{VDD-xHB} = 50 \text{ mA}$
Dynamic Resistance	R_D	—	3	5.0	Ω	$I_{VDD-xHB} = 50 \text{ mA}$
LO Gate Driver						
Low-Level Output Voltage	V_{OLL}	—	0.3	0.6	V	$I_{xLO} = 50 \text{ mA}$
High-Level Output Voltage	V_{OHL}	—	0.5	1.0	V	$I_{xLO} = -50 \text{ mA}$, $V_{OHL} = V_{DD} - V_{xLO}$
Peak Sink Current	I_{OHL}	—	1	—	A	$V_{xLO} = 0V$
Peak Source Current	I_{OLL}	—	1	—	A	$V_{xLO} = 12V$
HO Gate Driver						
Low-Level Output Voltage	V_{OLH}	—	0.3	0.6	V	$I_{xHO} = 50 \text{ mA}$
High-Level Output Voltage	V_{OHH}	—	0.5	1.0	V	$I_{xHO} = -50 \text{ mA}$, $V_{OHH} = V_{xHB} - V_{xHO}$
Peak Sink Current	I_{OHH}	—	1	—	A	$V_{xHO} = 0V$
Peak Source Current	I_{OLH}	—	1	—	A	$V_{xLO} = 12V$
Switching Specifications (Note 4)						
Lower Turn-Off Propagation Delay (xLI Falling to xLO Falling)	t_{LPHL}	—	35	75	ns	
Upper Turn-Off Propagation Delay (xHI Falling to xHO Falling)	t_{HPHL}	—	35	75	ns	
Lower Turn-On Propagation Delay (xLI Rising to xLO Rising)	t_{LPLH}	—	35	75	ns	

Note 1: Specification for packaged product only.

2: “x” in front of a pin name refers to either A or B (e.g., xHI can be either AHI or BHI).

3: $V_{IL(MAX)}$ = maximum positive voltage applied to the input which will be accepted by the device as a logic low.
 $V_{IH(MIN)}$ = minimum positive voltage applied to the input which will be accepted by the device as a logic high.

4: xLI/xHI mode with inputs non-overlapping, assumes xHS low before xLI goes high and xLO low before xHI goes high.

5: PWM mode (MIC4606-2) or LI/HI mode (MIC4606-1) with overlapping xLI/xHI inputs.

ELECTRICAL CHARACTERISTICS (CONTINUED)

Electrical Characteristics: Unless otherwise indicated: $V_{DD} = V_{xHB} = 12V$; $V_{EN} = 5V$; $V_{SS} = V_{xHS} = 0V$; No load on xLO or xHO; $T_A = +25^\circ C$. **Bold** values indicate $-40^\circ C \leq T_J \leq +125^\circ C$. (1,2)

Parameters	Sym.	Min.	Typ.	Max.	Units	Conditions
Upper Turn-On Propagation Delay (xHI Rising to xHO Rising)	t_{HPLH}	—	35	75	ns	
Output Rise/Fall Time	t_R/t_F	—	20	—	ns	$C_L = 1000 \text{ pF}$
Output Rise/Fall Time (3V to 9V)	t_R/t_F	—	0.8	—	μs	$C_L = 0.1 \text{ }\mu F$
Minimum Input Pulse Width that Changes the Output	t_{PW}	—	50	—	ns	
Switching Specifications (Note 5)						
Delay from xPWM High (or xLI Low) to xLO Low	$t_{L\text{OFF}}$	—	35	75	ns	
xLO Output Voltage Threshold for Low-Side FET to be Considered Off	$V_{L\text{OFF}}$	—	1.9	—	V	
Delay from xLO Off to xHO High	$t_{H\text{ON}}$	—	35	75	ns	
Delay from xPWM Low (or xHI Low) to xHO Low	$t_{H\text{OFF}}$	—	35	75	ns	
Switch Node Voltage Threshold Signaling xHO is Off	V_{SWTH}	1	2.2	4	V	
Delay Between xHO FET being Considered Off to xLO Turning On	$t_{L\text{ON}}$	—	35	75	ns	
For xHS Low/xLI High, Delay from xPWM/xHI Low to xLO High	$t_{L\text{ONHI}}$	—	80	150	ns	
Force xLO On if V_{SWTH} is Not Detected	t_{SWTO}	100	250	500	ns	

Note 1: Specification for packaged product only.

2: "x" in front of a pin name refers to either A or B (e.g., xHI can be either AHI or BHI).

3: $V_{IL(MAX)}$ = maximum positive voltage applied to the input which will be accepted by the device as a logic low.
 $V_{IH(MIN)}$ = minimum positive voltage applied to the input which will be accepted by the device as a logic high.

4: xLI/xHI mode with inputs non-overlapping, assumes xHS low before xLI goes high and xLO low before xHI goes high.

5: PWM mode (MIC4606-2) or LI/HI mode (MIC4606-1) with overlapping xLI/xHI inputs.

MIC4606

TEMPERATURE SPECIFICATIONS⁽¹⁾

Parameters	Sym.	Min.	Typ.	Max.	Units	Conditions
Temperature Ranges						
Storage Temperature Range	T_S	-60	—	+150	°C	
Junction Operating Temperature	T_J	-40	—	+125	°C	
Package Thermal Resistances						
Thermal Resistance, 16-Lead QFN	θ_{JA}	—	51	—	°C/W	
Thermal Resistance, 16-Lead TSSOP	θ_{JA}	—	97.5	—	°C/W	

Note 1: The maximum allowable power dissipation is a function of ambient temperature, the maximum allowable junction temperature and the thermal resistance from junction to air (i.e., T_A , T_J , θ_{JA}). Exceeding the maximum allowable power dissipation will cause the device operating junction temperature to exceed the maximum +125°C rating. Sustained junction temperatures above +125°C can impact the device reliability.

2.0 TIMING DIAGRAMS

2.1 Non-Overlapping LI/HI Input Mode (MIC4606-1)

In LI/HI Input mode, external xLI/xHI inputs are delayed to the point that xHS is low before xLI is pulled high and similarly, xLO is low before xHI goes high.

xHO goes high with a high signal on xHI after a typical delay of 35 ns ($t_{HP LH}$). xHI going low drives xHO low also with a typical delay of 35 ns ($t_{HP HL}$).

Likewise, xLI going high forces xLO high after a typical delay of 35 ns ($t_{LP LH}$) and xLO follows the low transition of xLI after a typical delay of 35 ns ($t_{LP HL}$).

xHO and xLO output rise and fall times (t_R/t_F) are typically 20 ns, driving 1000 pF capacitive loads.

All propagation delays are measured from the 50% voltage level and rise/fall times are measured 10% to 90%.

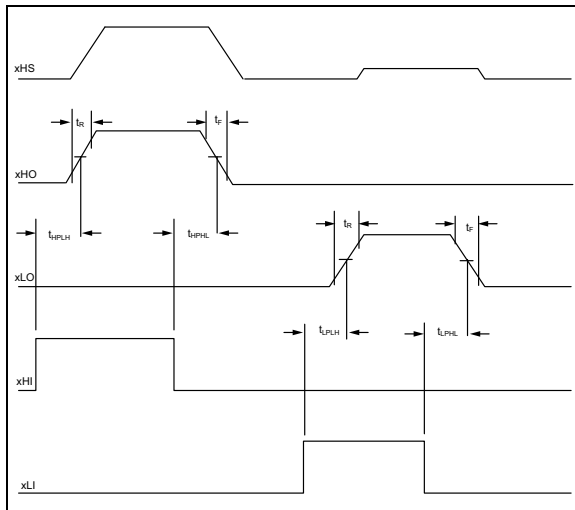

FIGURE 2-1: Separate Non-Overlapping LI/HI Input Mode (MIC4606-1).

2.2 Overlapping LI/HI Input Mode (MIC4606-1)

When xLI/xHI input high conditions overlap, xLO/xHO output states are dominated by the first output to be turned on. If xLI goes high (on) while xHO is high, xHO stays high until xHI goes low. After a delay of $t_{HO OFF}$, and when $xHS < 2.2V$, xLO goes high with a delay of $t_{LO ON}$. If xHS never trips the aforementioned internal comparator reference (2.2V), a falling xHI edge delayed by a typical 250 ns will set the "HS latch," allowing xLO to go high.

If xHS falls very fast, xLO will be held low by a 35 ns delay, gated by HI going low. Conversely, xHI going high (on) when xLO is high has no effect on the outputs until xLI is pulled low (off) and xLO falls to < 1.9V. Delay from xLI going low to xLO falling is $t_{LO OFF}$ and delay from $xLO < 1.9V$ to xHO being on is $t_{HO ON}$.

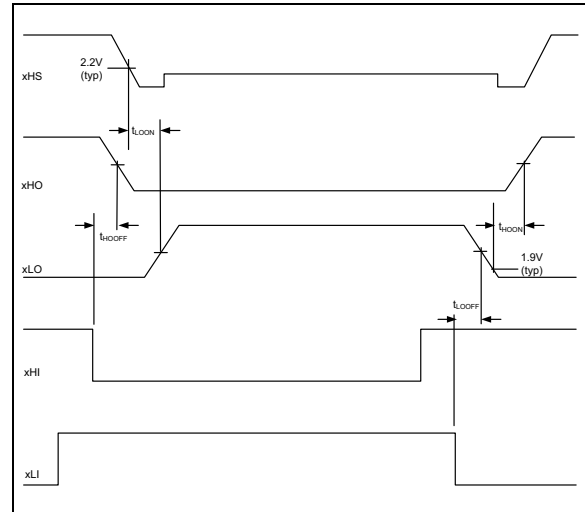

FIGURE 2-2: Separate Overlapping LI/HI Input Mode (MIC4606-1).

2.3 PWM Input Mode (MIC4606-2)

A low xPWM signal applied to the MIC4606-2 causes the xHO to go low, typically to 35 ns ($t_{HO OFF}$) after the xPWM input goes low. At this point, the switch node xHS falls (1-2).

When the xHS reaches 2.2V ($V_{SW TH}$), the external high-side MOSFET is deemed off and the xLO goes high, typically within 35 ns ($t_{LO ON}$) (3-4). The xHS falling below 2.2V sets a latch that can only be reset by the xPWM going high. This design prevents ringing on xHS from causing an indeterminate xLO state. Should xHS never trip the aforementioned internal comparator reference (2.2V), a falling xPWM edge delayed by 250 ns will set the "HS latch", allowing xLO to go high. An 80 ns delay, gated by xPWM going low, may determine the time to xLO going high for fast falling HS designs. xPWM going high forces xLO low in typically 35 ns ($t_{LO OFF}$) (5-6).

MIC4606

When xLO reaches 1.9V (V_{LOFF}), the low-side MOSFET is deemed off and xHO is allowed to go high. The delay between these two points is typically 35 ns (t_{HOON}) (7-8).

xHO and xLO output rise and fall times (t_R/t_F) are typically 20 ns, driving 1000 pF capacitive loads.

Note: All propagation delays are measured from the 50% voltage level and rise/fall times are measured from 10% to 90%.

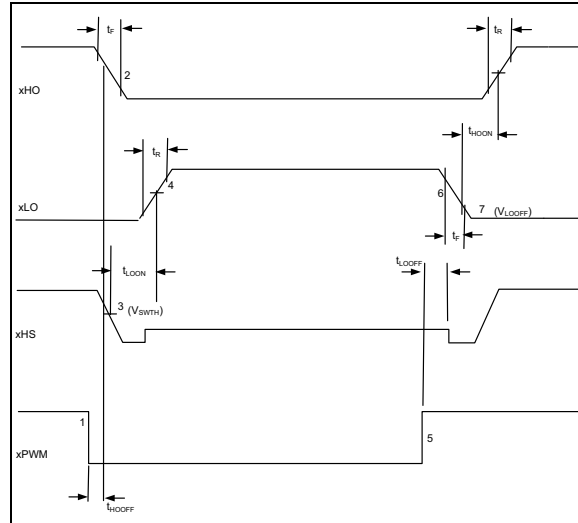

FIGURE 2-3: PWM Mode (MIC4606-2).

3.0 TYPICAL PERFORMANCE CURVES

Note: The graphs and tables provided following this note are a statistical summary based on a limited number of samples and are provided for informational purposes only. The performance characteristics listed herein are not tested or guaranteed. In some graphs or tables, the data presented may be outside the specified operating range (e.g., outside specified power supply range) and therefore outside the warranted range.

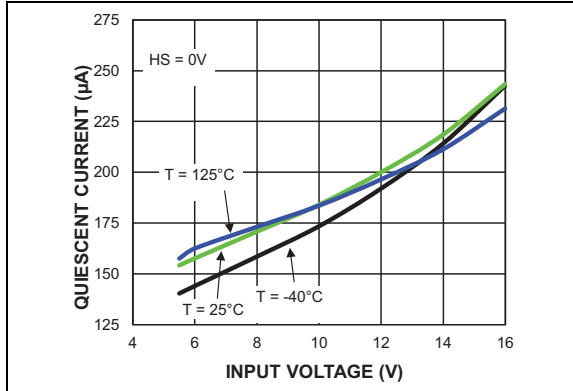

FIGURE 3-1: V_{DD} Quiescent Current vs. Input Voltage.

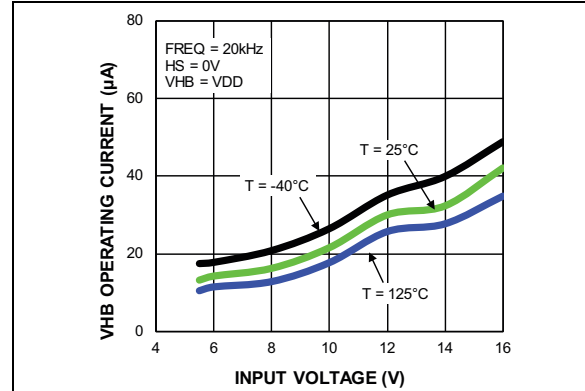

FIGURE 3-4: V_{HB} Operating Current vs. Input Voltage.

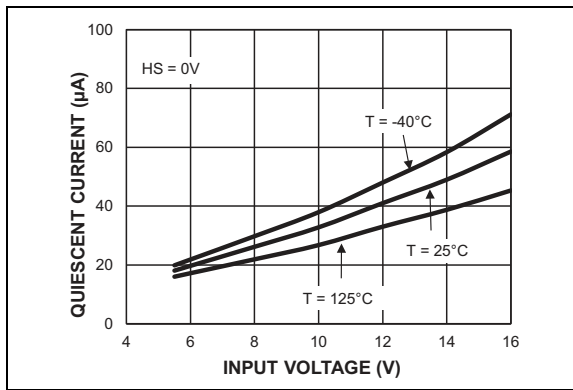

FIGURE 3-2: Shutdown Current vs. Input Voltage.

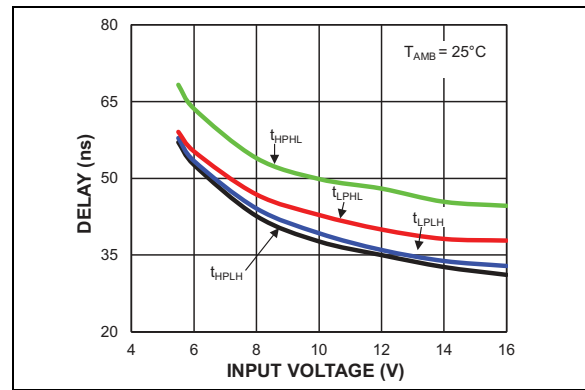

FIGURE 3-5: Propagation Delay vs. Input Voltage.

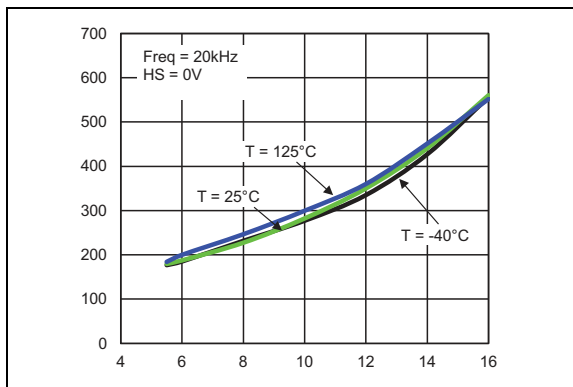

FIGURE 3-3: V_{DD} Operating Current vs. Input Voltage.

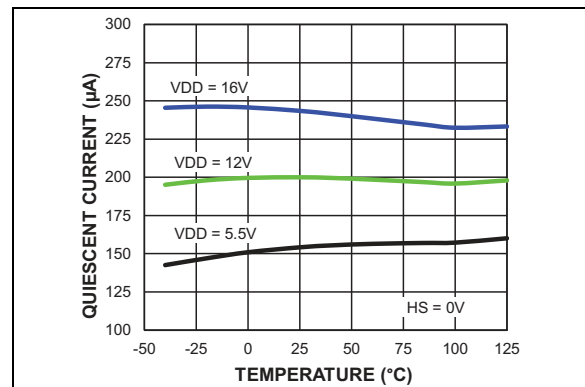

FIGURE 3-6: V_{DD} Quiescent Current vs. Temperature.

MIC4606

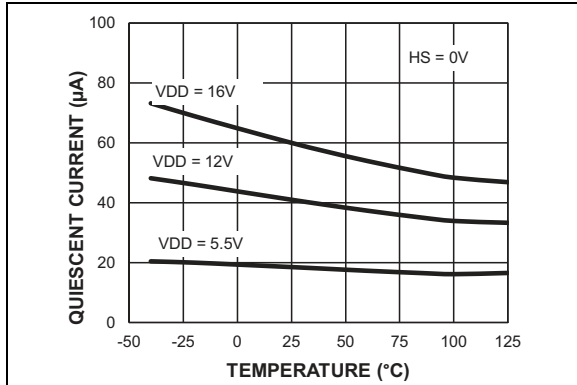

FIGURE 3-7: Shutdown Current vs. Temperature.

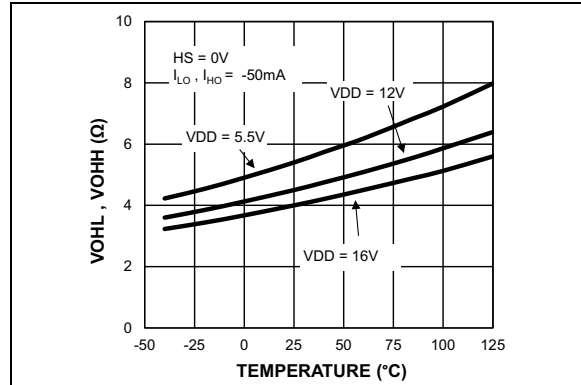

FIGURE 3-10: High-Level Output Resistance vs. Temperature.

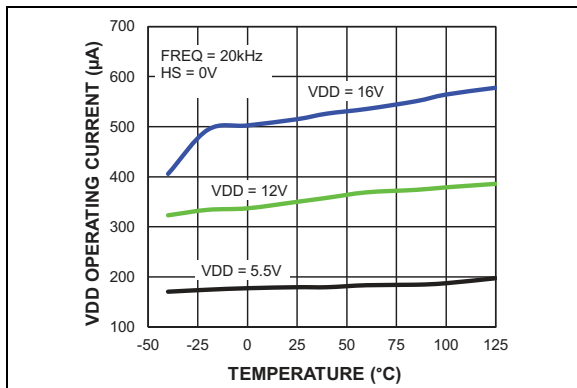

FIGURE 3-8: V_{DD} Operating Current vs. Temperature.

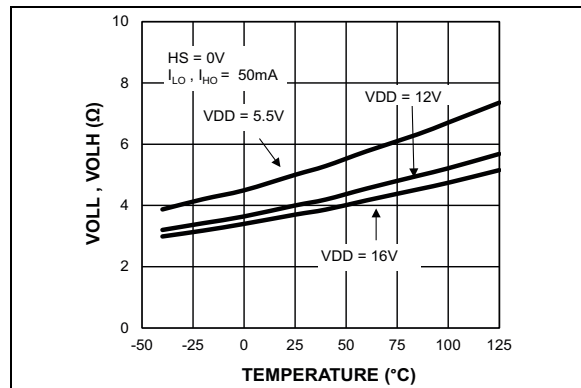

FIGURE 3-11: Low-Level Output Resistance vs. Temperature.

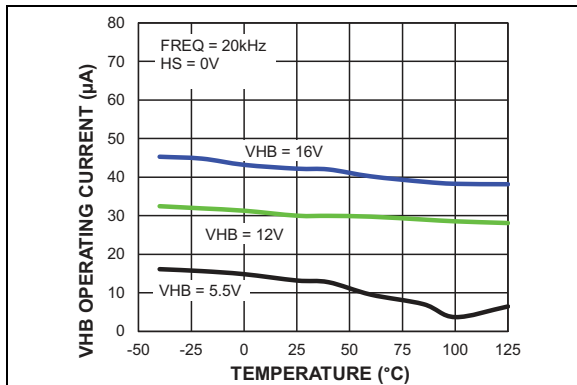

FIGURE 3-9: V_{HB} Operating Current vs. Temperature.

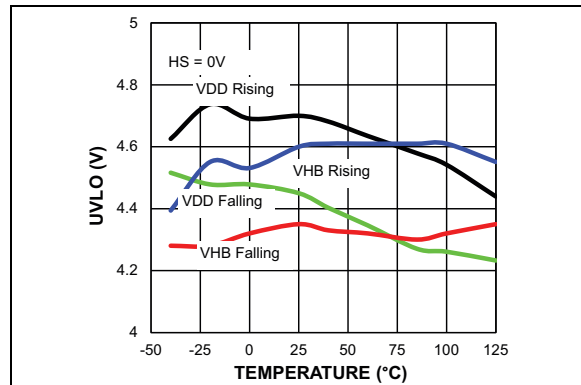

FIGURE 3-12: UVLO Thresholds vs. Temperature.

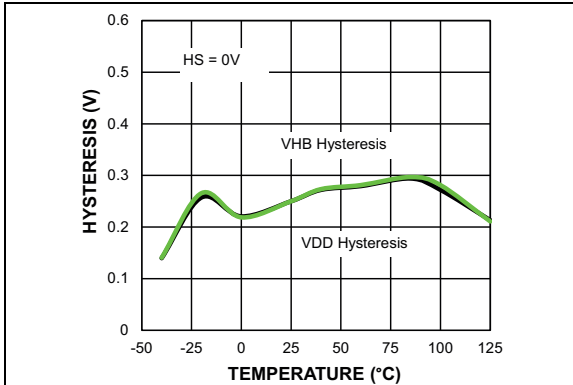

FIGURE 3-13: UVLO Hysteresis vs. Temperature.

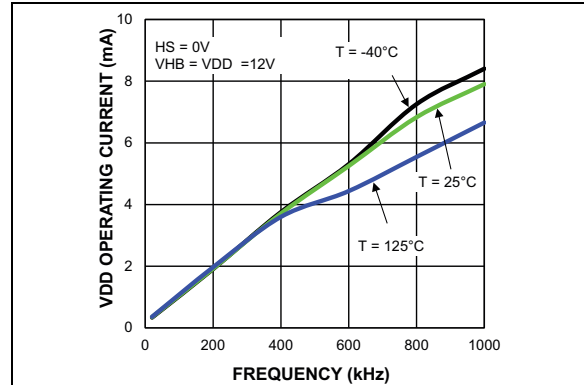

FIGURE 3-16: V_{DD} Operating Current vs. Frequency.

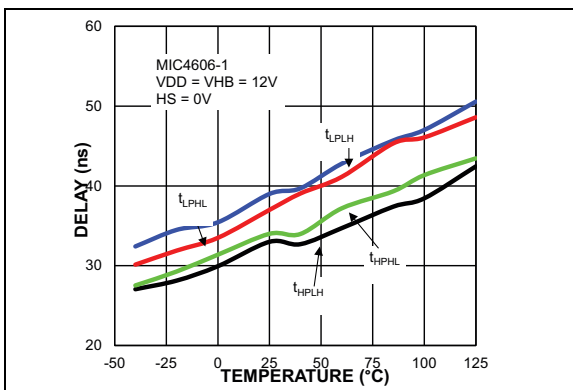

FIGURE 3-14: Propagation Delay vs. Temperature.

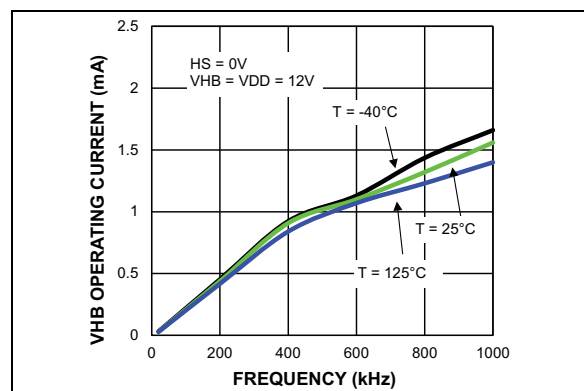

FIGURE 3-17: V_{HB} Operating Current vs. Frequency.

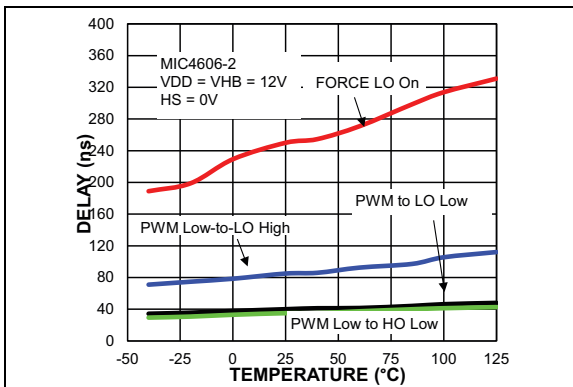

FIGURE 3-15: Propagation Delay (PWM) vs. Temperature.

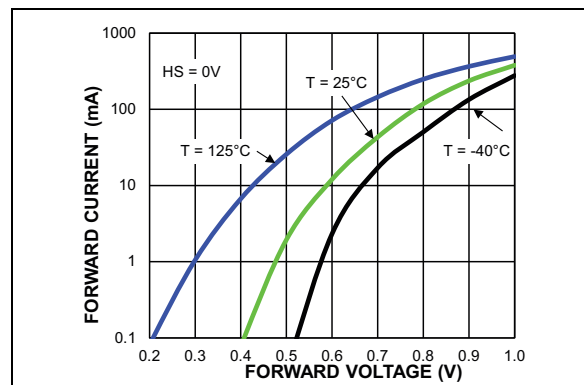

FIGURE 3-18: Bootstrap Diode I-V Characteristics.

MIC4606

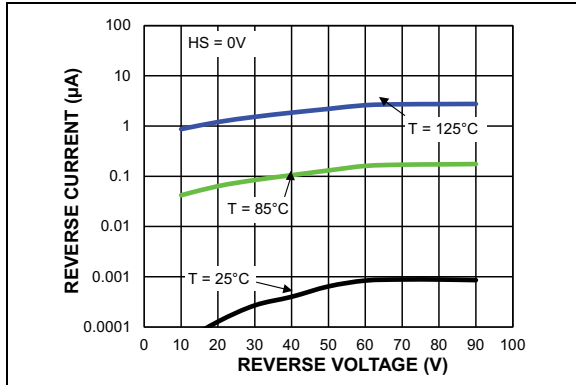

FIGURE 3-19: *Bootstrap Diode Reverse Current.*

4.0 PIN DESCRIPTIONS

The descriptions of the pins are listed in [Table 4-1](#) through [Table 4-4](#).

TABLE 4-1: MIC4606-1 QFN PIN FUNCTION TABLE

Pin Number	MIC4606-1 4x4 QFN	Description
1	NC	No connect.
2	AHB	Phase A high-side bootstrap supply. An external bootstrap capacitor is required. Connect the bootstrap capacitor between this pin and AHS. An on-chip bootstrap diode is connected from V_{DD} to AHB.
3	AHO	Phase A high-side drive output. Connect to the external high-side power MOSFET gate.
4	AHS	Phase A high-side drive reference connection. Connect to the external high-side power MOSFET source terminal. Connect a bootstrap capacitor between this pin and AHB.
5	ALO	Phase A low-side drive output. Connect to the external low-side power MOSFET gate.
6	VDD	Input Supply for gate drivers. Decouple this pin to V_{SS} with a $>1.0 \mu\text{F}$ capacitor.
7	VSS	Driver reference supply input. Connect to the power ground of the external circuitry.
8	BLO	Phase B low-side drive output. Connect to the external low-side power MOSFET gate.
9	BHS	Phase B high-side drive reference connection. Connect to the external high-side power MOSFET source terminal. Connect a bootstrap capacitor between this pin and BHB.
10	BHO	Phase B high-side drive output. Connect to the external high-side power MOSFET gate.
11	BHB	Phase B high-side bootstrap supply. An external bootstrap capacitor is required. Connect the bootstrap capacitor between this pin and BHS. An on-chip bootstrap diode is connected from V_{DD} to BHB.
12	EN	Enable input. A logic high on the enable pin results in normal operation. A logic low disables all outputs and places the driver into a Low-Current Shutdown mode. Do not leave this pin floating.
13	BHI	Phase B high-side drive input.
14	BLI	Phase B low-side drive input.
15	ALI	Phase A low-side drive input.
16	AHI	Phase A high-side drive input.
EP	ePad	Exposed thermal pad. Connect to V_{SS} . A connection to the ground plane is necessary for optimum thermal performance.

MIC4606

TABLE 4-2: MIC4606-2 QFN PIN FUNCTION TABLE

Pin Number	MIC4606-2 4x4 QFN	Description
1	NC	No connect.
2	AHB	Phase A high-side bootstrap supply. An external bootstrap capacitor is required. Connect the bootstrap capacitor between this pin and AHS. An on-chip bootstrap diode is connected from V_{DD} to AHB.
3	AHO	Phase A high-side drive output. Connect to the external high-side power MOSFET gate.
4	AHS	Phase A high-side drive reference connection. Connect to the external high-side power MOSFET source terminal. Connect a bootstrap capacitor between this pin and AHB.
5	ALO	Phase A low-side drive output. Connect to the external low-side power MOSFET gate.
6	VDD	Input supply for gate drivers. Decouple this pin to V_{SS} with a $>1.0 \mu\text{F}$ capacitor.
7	VSS	Driver reference supply input. Connect to the power ground of the external circuitry.
8	BLO	Phase B low-side drive output. Connect to the external low-side power MOSFET gate.
9	BHS	Phase B high-side drive reference connection. Connect to the external high-side power MOSFET source terminal. Connect a bootstrap capacitor between this pin and BHB.
10	BHO	Phase B high-side drive output. Connect to the external high-side power MOSFET gate.
11	BHB	Phase B high-side bootstrap supply. An external bootstrap capacitor is required. Connect the bootstrap capacitor between this pin and BHS. An on-chip bootstrap diode is connected from V_{DD} to BHB.
12	EN	Enable input. A logic high on the enable pin results in normal operation. A logic low disables all outputs and places the driver into a Low-Current Shutdown mode. Do not leave this pin floating.
13	BPWM	Phase B PWM input for single input signal drive.
14	NC	No connect.
15	NC	No connect.
16	APWM	Phase A PWM input for single input signal drive.
EP	ePad	Exposed thermal pad. Connect to V_{SS} . A connection to the ground plane is necessary for optimum thermal performance.

TABLE 4-3: MIC4606-1 TSSOP PIN FUNCTION TABLE

Pin Number	MIC4606-1 TSSOP	Description
1	BHB	Phase B high-side bootstrap supply. An external bootstrap capacitor is required. Connect the bootstrap capacitor between this pin and BHS. An on-chip bootstrap diode is connected from V_{DD} to BHB.
2	EN	Enable input. A logic high on the enable pin results in normal operation. A logic low disables all outputs and places the driver into a Low-Current Shutdown mode. Do not leave this pin floating.
3	BHI	Phase B high-side drive input.
4	BLI	Phase B low-side drive input.
5	ALI	Phase A low-side drive input.
6	AHI	Phase A high-side drive input.
7	NC	No connect.
8	AHB	Phase A high-side bootstrap supply. An external bootstrap capacitor is required. Connect the bootstrap capacitor between this pin and AHS. An on-chip bootstrap diode is connected from V_{DD} to AHB.
9	AHO	Phase A high-side drive output. Connect to the external high-side power MOSFET gate.
10	AHS	Phase A high-side drive reference connection. Connect to the external high-side power MOSFET source terminal. Connect a bootstrap capacitor between this pin and AHB.
11	ALO	Phase A low-side drive output. Connect to the external low-side power MOSFET gate.
12	VDD	Input supply for gate drivers. Decouple this pin to V_{SS} with a $>1.0 \mu\text{F}$ capacitor.
13	VSS	Driver reference supply input. Connect to the power ground of the external circuitry.
14	BLO	Phase B low-side drive output. Connect to the external low-side power MOSFET gate.
15	BHS	Phase B high-side drive reference connection. Connect to the external high-side power MOSFET source terminal. Connect a bootstrap capacitor between this pin and BHB.
16	BHO	Phase B high-side drive output. Connect to the external high-side power MOSFET gate.

MIC4606

TABLE 4-4: MIC4606-2 TSSOP PIN FUNCTION TABLE

Pin Number	MIC4606-2 TSSOP	Description
1	BHB	Phase B high-side bootstrap supply. An external bootstrap capacitor is required. Connect the bootstrap capacitor between this pin and BHS. An on-chip bootstrap diode is connected from V_{DD} to BHB.
2	EN	Enable input. A logic high on the enable pin results in normal operation. A logic low disables all outputs and places the driver into a Low-Current Shutdown mode. Do not leave this pin floating.
3	BPWM	Phase B PWM input for single input signal drive.
4	NC	No connect.
5	NC	No connect.
6	APWM	Phase A PWM input for single input signal drive.
7	NC	No connect.
8	AHB	Phase A high-side bootstrap supply. An external bootstrap capacitor is required. Connect the bootstrap capacitor between this pin and AHS. An on-chip bootstrap diode is connected from V_{DD} to AHB.
9	AHO	Phase A high-side drive output. Connect to the external high-side power MOSFET gate.
10	AHS	Phase A high-side drive reference connection. Connect to the external high-side power MOSFET source terminal. Connect a bootstrap capacitor between this pin and AHB.
11	ALO	Phase A low-side drive output. Connect to the external low-side power MOSFET gate.
12	VDD	Input supply for gate drivers. Decouple this pin to V_{SS} with a $>1.0 \mu\text{F}$ capacitor.
13	VSS	Driver reference supply input. Connect to the power ground of the external circuitry.
14	BLO	Phase B low-side drive output. Connect to the external low-side power MOSFET gate.
15	BHS	Phase B high-side drive reference connection. Connect to the external high-side power MOSFET source terminal. Connect a bootstrap capacitor between this pin and BHB.
16	BHO	Phase B high-side drive output. Connect to the external high-side power MOSFET gate.

5.0 FUNCTIONAL DIAGRAM

For xHO to be high, the xHI must be high and the xLO must be low. xHO going high is delayed by xLO falling below 1.9V. The xHI and xLI inputs must not rise at the same time to prevent a glitch from occurring on the output. A minimum 50 ns delay between both inputs is recommended.

xLO is turned off very quickly on the xLI falling edge. xLO going high is delayed by the longer of the 35 ns delay of the xHO control signal going "off" or the RS latch being set.

The latch is set by the quicker of either the falling edge of xHS or an xLI gated delay of 250 ns. The latch is present to lock out xLO bounce due to ringing on xHS. If xHS never adequately falls due to the absence of or the presence of a very weak external pull-down on xHS, the gated delay of 250 ns at xLI will set the latch, allowing xLO to transition high. This, in turn, allows the xLI start-up pulse to charge the bootstrap capacitor if the load inductor current is very low and xHS is uncontrolled. The latch is reset by the xLI falling edge.

There is one external enable pin that controls both phases.

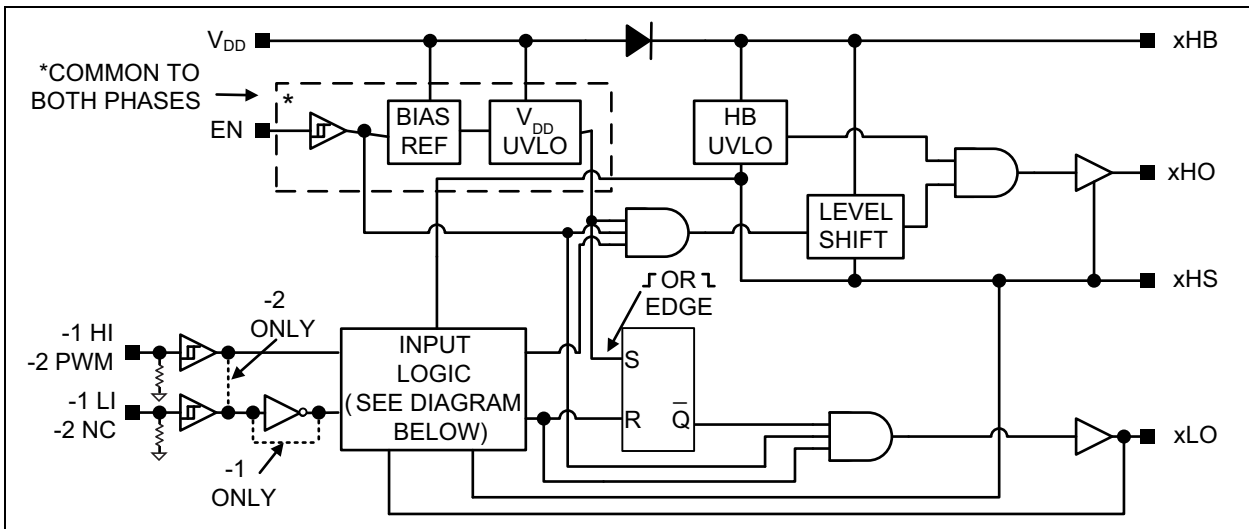

FIGURE 5-1: MIC4606 xPhase Top-Level Block Diagram.

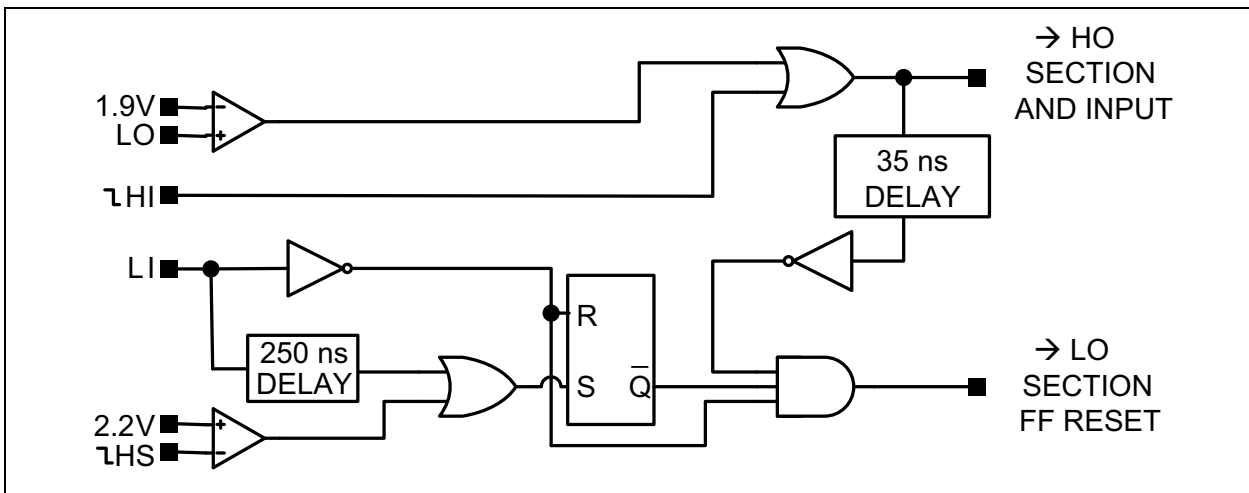

FIGURE 5-2: Input Logic Block in Figure 5-1.

MIC4606

NOTES:

6.0 FUNCTIONAL DESCRIPTION

The MIC4606 is a noninverting, 85V full-bridge MOSFET driver designed to independently drive all four N-channel MOSFETs in the bridge. The MIC4606 offers a wide 5.5V to 16V operating supply range with either four independent TTL inputs (MIC4606-1) or two PWM inputs, one for each phase (MIC4606-2). Refer to Figure 5-1.

The drivers contain input buffers with hysteresis, three independent UVLO circuits (two high side and one low side) and four output drivers. The high-side output drivers utilize a high-speed level-shifting circuit that is referenced to its HS pin. Each phase has an internal diode that is used by the bootstrap circuits to provide the drive voltages for each of the two high-side outputs.

6.1 Start-up and UVLO

The UVLO circuits force the driver's outputs low until the supply voltage exceeds the UVLO threshold. The low-side UVLO circuit monitors the voltage between the V_{DD} and V_{SS} pins. The high-side UVLO circuits monitor the voltage between the xHB and xHS pins. Hysteresis in the UVLO circuits prevent noise and finite circuit impedance from causing chatter during turn-on.

6.2 Enable Inputs

There is one external enable pin that controls both phases. A logic high on the enable pin (EN) allows for start-up of both phases and normal operation. Conversely, when a logic low is applied on the enable pin, both phases turn off and the device enters a Low-Current Shutdown mode. The startup time until normal operation after rising edge of enable pin (EN) is approximately 100 μ s. As soon as the device enters normal operation mode, the high side output pin (xHO) takes the status according to the input pin (xHI for the -1 option or xPWM for the -2 option). Entering normal operation mode for low side, the xLO pin only becomes active after an edge of the input pin (xLI or xPWM) falls. All outputs (xHO and xLO) are pulled low when EN is low. The EN pin must not be left floating.

6.3 Input Stage

All input pins (xLI and xHI) are referenced to the V_{SS} pin. The MIC4606 has a TTL-compatible input range and can be used with input signals with amplitude less than the supply voltage. The threshold level is independent of the V_{DD} supply voltage and there is no dependence between $I_{V_{DD}}$ and the input signal amplitude. This feature makes the MIC4606 an excellent level translator that will drive high-level gate threshold MOSFETs from a low-voltage PWM IC.

6.4 Low-Side Driver

A block diagram of the low-side driver is shown in Figure 6-1. It drives a ground (V_{SS} pin) referenced N-channel MOSFET.

Low impedances in the driver allow the external MOSFET to be turned on and off quickly. The rail-to-rail drive capability of the output ensures high noise immunity and a low $R_{DS(ON)}$ from the external MOSFET.

A high level applied to the xLI pin causes V_{DD} to be applied to the gate of the external MOSFET. A low level on the xLI pin grounds the gate of the external MOSFET.

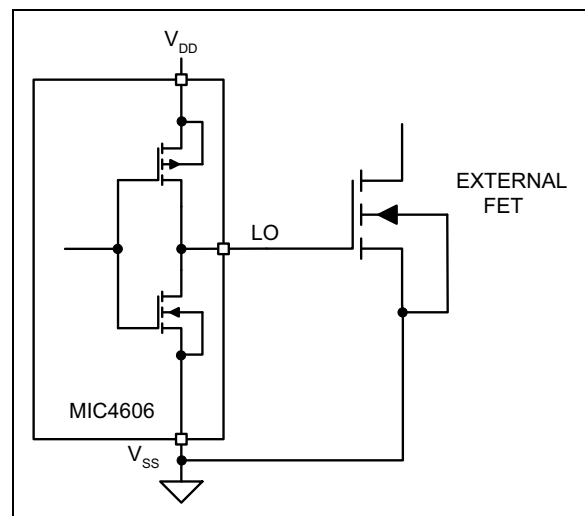

FIGURE 6-1: Low-Side Driver Block Diagram.

6.5 High-Side Driver and Bootstrap Circuit

A block diagram of the high-side driver and bootstrap circuit is shown in Figure 6-2. This driver is designed to drive a floating N-channel MOSFET, whose source terminal is referenced to the HS pin.

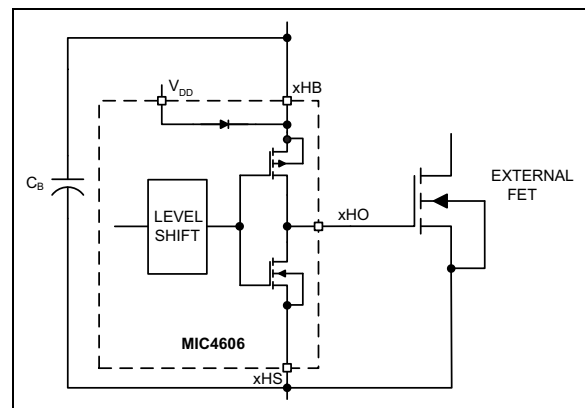

FIGURE 6-2: High-Side Driver and Bootstrap Circuit Block Diagram.

MIC4606

A low-power, high-speed, level-shifting circuit isolates the low-side (V_{SS} pin) referenced circuitry from the high-side (xHS pin) referenced driver. Power to the high-side driver and UVLO circuit is supplied by the bootstrap capacitor (C_B), while the voltage level of the xHS pin is shifted high.

The bootstrap circuit consists of an internal diode and external capacitor, C_B . In a typical application, such as the motor driver shown in Figure 6-3 (only Phase A is illustrated), the AHS pin is at ground potential while the low-side MOSFET is on. The internal diode allows

capacitor C_B to charge up to $V_{DD} - V_F$ during this time (where V_F is the forward voltage drop of the internal diode). After the low-side MOSFET is turned off and the AHO pin turns on, the voltage across capacitor C_B is applied to the gate of the high-side external MOSFET. As the high-side MOSFET turns on, voltage on the AHS pin rises with the source of the high-side MOSFET until it reaches V_{IN} . As the AHS and AHB pins rise, the internal diode is reverse biased, preventing capacitor C_B from discharging.

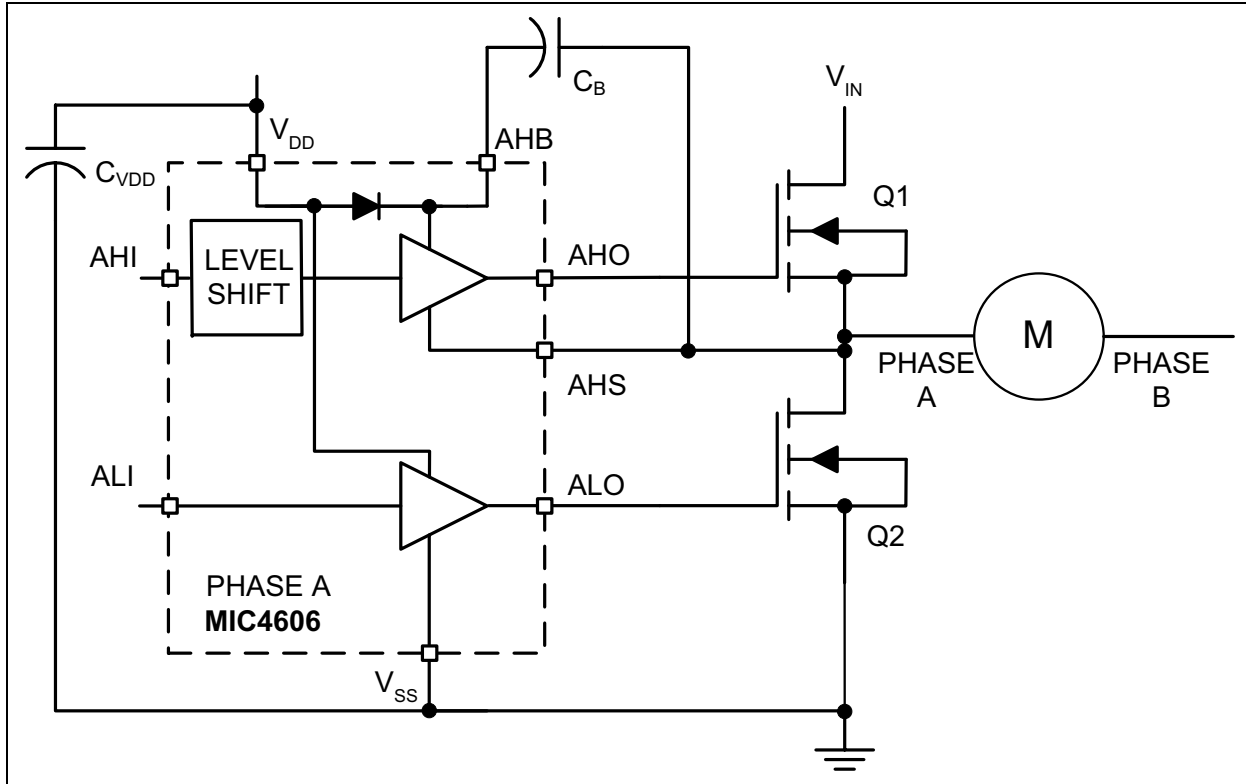

FIGURE 6-3: MIC4606 Motor Driver Example.

6.6 Programmable Gate Drive

The MIC4606 offers programmable gate drive, which means the MOSFET gate drive (gate-to-source voltage) equals the V_{DD} voltage. This feature offers designers flexibility in driving the MOSFETs. Different MOSFETs require different V_{GS} characteristics for optimum $R_{DS(ON)}$ performance. Typically, the higher the gate voltage (up to 16V), the lower the $R_{DS(ON)}$ achieved. For example, a NTMSF4899NF MOSFET can be driven to the ON state with a gate voltage of 5.5V, but $R_{DS(ON)}$ is 5.2 m Ω . If driven to 10V, $R_{DS(ON)}$ is 4.1 m Ω – a decrease of 20%. In low-current applications, the losses due to $R_{DS(ON)}$ are minimal, but in battery-powered high-current motor drive applications, such as power tools, the difference in $R_{DS(ON)}$ can cut into the efficiency budget, reducing run time.

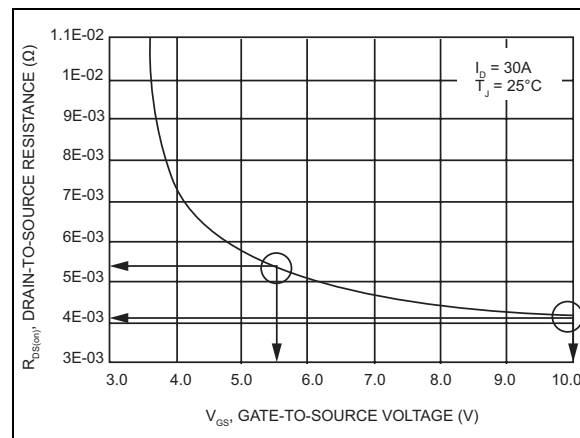

FIGURE 6-4: MOSFET $R_{DS(ON)}$ vs. V_{GS} .

7.0 APPLICATION INFORMATION

7.1 Adaptive Dead Time

The door lock/unlock circuit diagram, shown in Figure 7-2, is used to illustrate the importance of the adaptive dead-time feature of the MIC4606. For each phase, it is important that both MOSFETs are not conducting at the same time or V_{IN} will be shorted to ground and current will “shoot through” the MOSFETs. Excessive shoot-through causes higher power dissipation in the MOSFETs, voltage spikes and ringing. The high switching current and voltage ringing generate conducted and radiated EMI.

Minimizing shoot-through can be done passively, actively or through a combination of both. Passive shoot-through protection can be achieved by implementing delays between the high and low gate drivers to prevent both MOSFETs from being on at the same time. These delays can be adjusted for different applications. Although simple, the disadvantage of this approach is that it requires long delays to account for process and temperature variations in the MOSFET and MOSFET driver.

Adaptive dead time monitors voltages on the gate drive outputs and switch node to determine when to switch the MOSFETs on and off. This active approach adjusts the delays to account for some of the variations, but it too has its disadvantages. High currents and fast switching voltages in the gate drive and return paths can cause parasitic ringing to turn the MOSFETs back on, even while the gate driver output is low. Another disadvantage is that the driver cannot monitor the gate voltage inside the MOSFET. Figure 7-1 shows an equivalent circuit of the high-side gate drive, including parasitic.

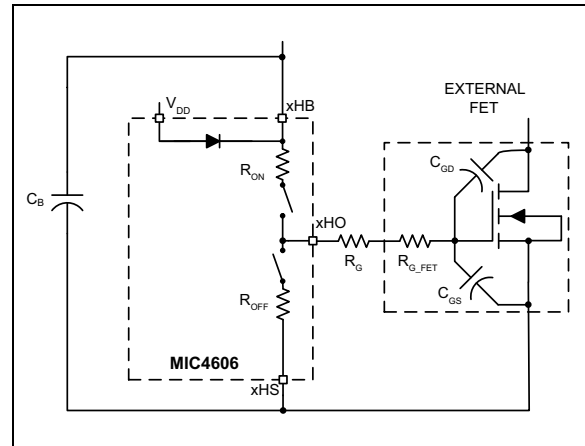

FIGURE 7-1: MIC4606 Driving an External MOSFET.

The internal gate resistance (R_{G_FET}) and any external damping resistor (R_G) isolate the MOSFET's gate from the driver output. There is a delay between when the driver output goes low and the MOSFET turns off. This turn-off delay is usually specified in the MOSFET data sheet. This delay increases when an external damping resistor is used.

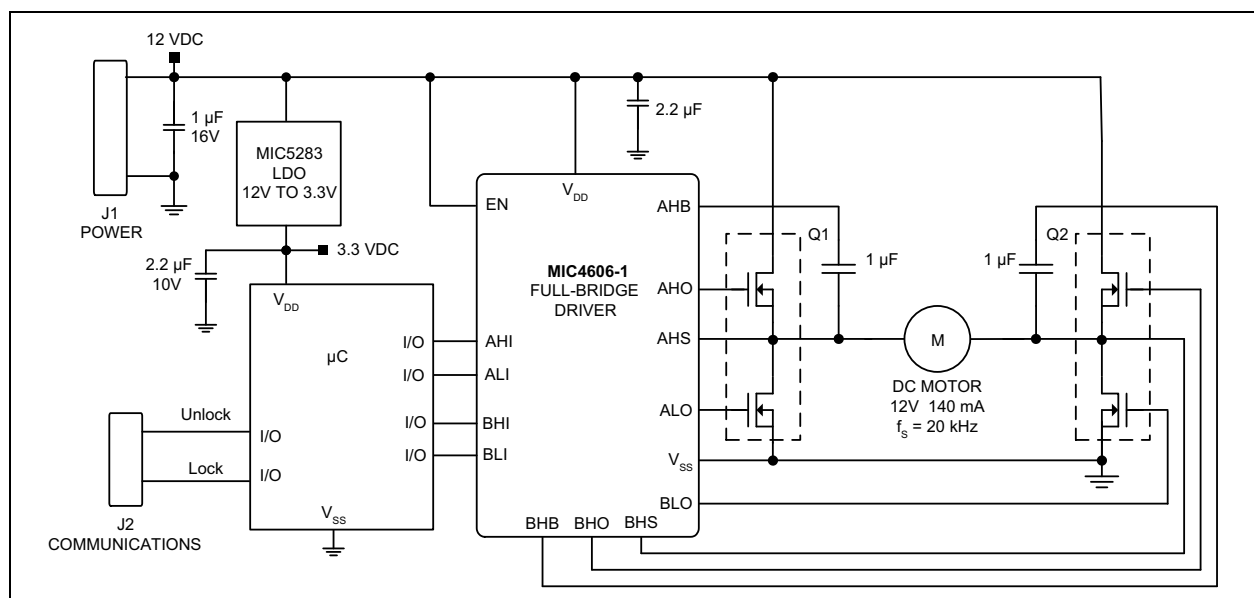

FIGURE 7-2: Door Lock/Unlock Circuit.

MIC4606

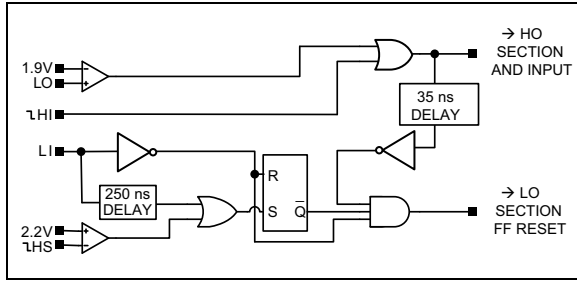

FIGURE 7-3: Adaptive Dead-Time Logic Diagram.

The MIC4606 uses a combination of active sensing and passive delay to ensure that both MOSFETs are not on at the same time. Figure 7-3 illustrates how the adaptive dead-time circuitry works.

For the MIC4606-2, a high level on the xPWM pin causes /HI to go high and /LI to go low. This causes the xLO pin to go low. The MIC4606 monitors the xLO pin voltage and prevents the xHO pin from turning on until the voltage on the xLO pin reaches the V_{LOOFF} threshold. After a short delay, the MIC4606 drives the xHO pin high. Monitoring the xLO voltage eliminates any excessive delay due to the MOSFET drivers turn-off time and the short delay accounts for the MOSFET turn-off delay, as well as letting the xLO pin voltage settle out. An external resistor between the xLO output and the MOSFET may affect the performance of the xLO pin monitoring circuit and is not recommended.

A low on the xPWM pin causes /HI to go low and /LI to go high. This causes the xHO pin to go low after a short delay (t_{HOFF}). Before the xLO pin can go high, the voltage on the switching node (xHS pin) must have dropped to 2.2V. Monitoring the switch voltage instead of the xHO pin voltage eliminates timing variations and excessive delays due to the high-side MOSFET turn-off. The xLO driver turns on after a short delay (t_{LON}). Once the xLO driver is turned on, it is latched on until the xPWM signal goes high. This prevents any ringing or oscillations on the switch node or xHS pin from turning off the xLO driver. If the xPWM pin goes low and the voltage on the xHS pin does not cross the V_{SWTH} threshold, the xLO pin will be forced high after a short delay (t_{SWTO}), insuring proper operation.

The internal logic circuits also insure a “first on” priority at the inputs. If the xHO output is high, the xLI pin is inhibited. A high signal or noise glitch on the xLI pin has no effect on the xHO or xLO outputs until the xHI pin goes low. Similarly, the xLO being high holds xHO low until xLI and xLO are low.

Fast propagation delay between the input and output drive waveform is desirable. It improves overcurrent protection by decreasing the response time between the control signal and the MOSFET gate drive. Minimizing propagation delay also minimizes phase-shift errors in power supplies with wide bandwidth control loops.

Care must be taken to ensure that the input signal pulse width is greater than the minimum specified pulse width. An input signal that is less than the minimum pulse width may result in no output pulse or an output pulse whose width is significantly less than the input.

The maximum duty cycle (ratio of high-side on-time to switching period) is determined by the time required for the C_B capacitor to charge during the off-time. Adequate time must be allowed for the C_B capacitor to charge up before the high-side driver is turned back on.

Although the adaptive dead-time circuit in the MIC4606 prevents the driver from turning both MOSFETs on at the same time, other factors outside of the anti-shoot-through circuit’s control can cause shoot-through. Other factors include ringing on the gate drive node and capacitive coupling of the switching node voltage on the gate of the low-side MOSFET.

The scope photo in Figure 7-4 shows the dead time (< 20 ns) between the high and low-side MOSFET transitions as the low-side driver switches off, while the high-side driver transitions from off to on.

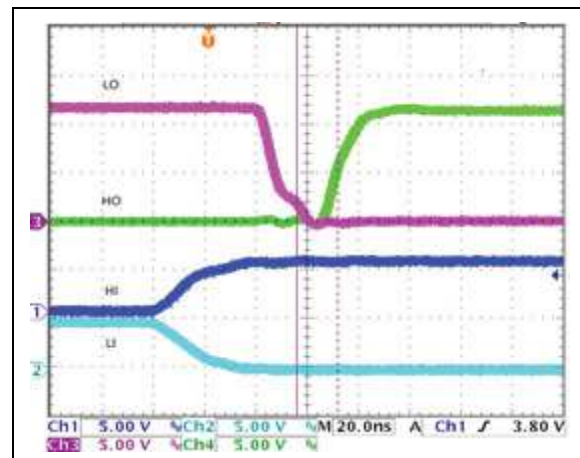

FIGURE 7-4: Adaptive Dead-Time LO (Low) to HO (High).

Table 7-1 contains truth tables for the MIC4606-1 (Independent TTL inputs) and Table 7-2 is for the MIC4606-2 (PWM inputs) that details the “first on” priority as well as the failsafe delay (t_{SWTO}).

TABLE 7-1: MIC4606-1 TRUTH TABLE

xLI	xHI	xLO	xHO	Comments
0	0	0	0	Both outputs off.
0	1	0	1	xHO will not go high until xLO falls below 1.9V.
1	0	1	0	xLO will be delayed an extra 250 ns if xHS never falls below 2.2V.
1	1	x	x	First on stays on until input of same goes low.

TABLE 7-2: MIC4606-2 TRUTH TABLE

xPWM	xLO	xHO	Comments
0	1	0	xLO will be delayed an extra 250 ns if xHS never falls below 2.2V.
1	0	1	xHO will not go high until xLO falls below 1.9V.

7.2 HS Pin Clamp

A resistor/diode clamp between the motor phase node and the xHS pin is necessary to clamp large negative glitches or pulses on the xHS pin.

Figure 7-5 shows the Phase A section high-side and low-side MOSFETs connected to one phase of the motor. There is a brief period of time (dead time) between switching to prevent both MOSFETs from being on at the same time. When the high-side MOSFET is conducting during the on-time state, current flows into the motor. After the high-side MOSFET turns off, but before the low-side MOSFET turns on, current from the motor flows through the body diode in parallel with the low-side MOSFET. Depending upon the turn-on time of the body diode, the motor current and circuit parasitics, the initial negative voltage on the switch node can be several volts or more. The forward voltage drop of the body diode can be several volts, depending on the body diode characteristics and motor current.

Even though the xHS pins are rated for negative voltage, it is good practice to clamp the negative voltage on the xHS pin with a resistor and diode to prevent excessive negative voltage from damaging the driver. Depending upon the application and amount of negative voltage on the switch node, a 3Ω resistor is recommended. If the xHS pin voltage exceeds 0.7V, a diode or Schottky diode between the xHS pin and ground is recommended. The diode reverse voltage rating must be greater than the high-voltage input supply (V_{IN}). Larger values of resistance can be used if necessary.

Adding a series resistor in the switch node limits the peak high-side driver current during turn-off, which affects the switching speed of the high-side driver. The resistor in series with the HO pin may be reduced to help compensate for the extra HS pin resistance.

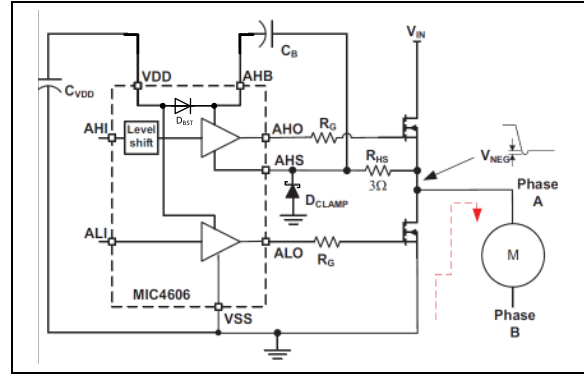

FIGURE 7-5: Negative HS Pin Voltage.

7.3 Power Dissipation Considerations

Power dissipation in the driver can be separated into three areas:

- Internal diode dissipation in the bootstrap circuit
- Internal driver dissipation
- Quiescent current dissipation used to supply the internal logic and control functions.

7.4 Bootstrap Circuit Power Dissipation

Power dissipation of the internal bootstrap diode primarily comes from the average charging current of the bootstrap capacitor (C_B), multiplied by the forward voltage drop of the diode. Secondary sources of diode power dissipation are the reverse leakage current and reverse recovery effects of the diode.

The average current drawn by repeated charging of the high-side MOSFET is calculated by:

EQUATION 7-1:

$$I_{F(AVE)} = Q_{GATE} \times f_S$$

Where:

Q_{GATE} = Total Gate Charge at V_{HB}

f_S = Gate Drive Switching Frequency

The average power dissipated by the forward voltage drop of the diode equals:

EQUATION 7-2:

$$P_{DIODEfwd} = I_{F(AVE)} \times V_F$$

Where:

V_F = Diode Forward Voltage Drop

MIC4606

There are two phases in the MIC4606. The power dissipation for each of the bootstrap diodes must be calculated and summed to obtain the total bootstrap diode power dissipation for the package.

The value of V_F should be taken at the peak current through the diode; however, this current is difficult to calculate because of differences in source impedances. The peak current can either be measured or the value of V_F at the average current can be used, which will yield a good approximation of diode power dissipation.

The reverse leakage current of the internal bootstrap diode is typically 3 μA at a reverse voltage of 85V at +125°C. Power dissipation due to reverse leakage is typically much less than 1 mW and can be ignored.

An optional external bootstrap diode may be used instead of the internal diode (Figure 7-6). An external diode may be useful if high gate charge MOSFETs are being driven and the power dissipation of the internal diode is contributing to excessive die temperatures. The voltage drop of the external diode must be less than the internal diode for this option to work. The reverse voltage across the diode will be equal to the input voltage minus the V_{DD} supply voltage. The above equations can be used to calculate power dissipation in the external diode; however, if the external diode has significant reverse leakage current, the power dissipated in that diode due to reverse leakage can be calculated as:

EQUATION 7-3:

$$P_{DIODErev} = I_R \times V_{REV} \times (1 - D)$$

Where:

- I_R = Reverse Current Flow at V_{REV} and T_J
- V_{REV} = Diode Reverse Voltage
- D = Duty Cycle ($t_{ON} \times f_S$)

The on-time is the time the high-side switch is conducting. In most topologies, the diode is reverse biased during the switching cycle off-time.

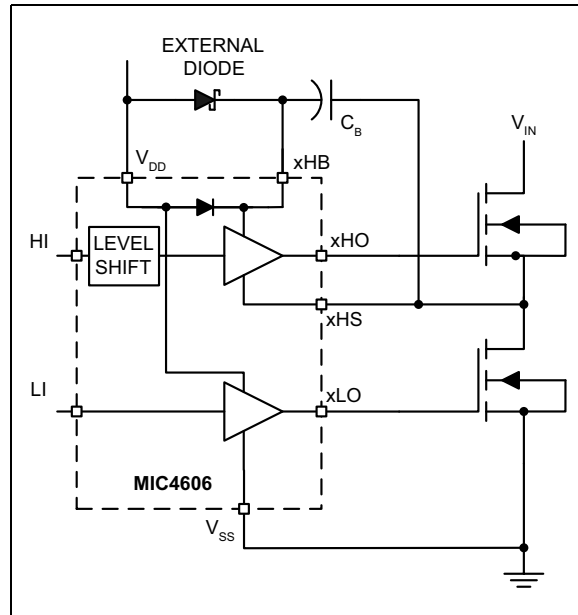

FIGURE 7-6: Optional Bootstrap Diode.

7.5 Gate Driver Power Dissipation

Power dissipation in the output driver stage is mainly caused by charging and discharging the gate to source and gate to drain capacitance of the external MOSFET. Figure 7-7 shows a simplified equivalent circuit of the MIC4606 driving an external high-side MOSFET.

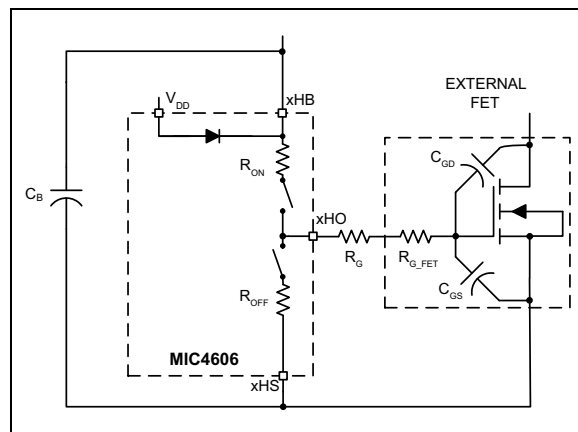

FIGURE 7-7: MIC4606 Driving an External High-Side MOSFET.

7.6 Dissipation During the External MOSFET Turn-On

Energy from capacitor C_B is used to charge up the input capacitance of the MOSFET (C_{GD} and C_{GS}). The energy delivered to the MOSFET is dissipated in the three resistive components, R_{ON} , R_G and R_{G_FET} . R_{ON} is the on-resistance of the upper driver MOSFET in the MIC4606. R_G is the series resistor (if any) between the driver and the MOSFET. R_{G_FET} is the gate resistance of the MOSFET. R_{G_FET} is usually listed in the power MOSFET's specifications. The ESR of capacitor C_B and the resistance of the connecting etch can be ignored, since they are much less than R_{ON} and R_{G_FET} .

The effective capacitances of C_{GD} and C_{GS} are difficult to calculate because they vary nonlinearly with I_D , V_{GS} and V_{DS} . Fortunately, most power MOSFET specifications include a typical graph of total gate charge versus V_{GS} . Figure 7-8 shows a typical gate charge curve for an arbitrary power MOSFET. This chart shows that for a gate voltage of 10V, the MOSFET requires about 23.5 nC of charge. The energy dissipated by the resistive components of the gate drive circuit during turn-on is calculated as:

EQUATION 7-4:

$$E = \frac{1}{2} \times C_{ISS} \times V_{GS}^2$$

Where:

C_{ISS} = Total Gate Capacitance of the MOSFET

but

EQUATION 7-5:

$$Q = C \times V$$

so

EQUATION 7-6:

$$E = \frac{1}{2} \times Q_G \times V_{GS}$$

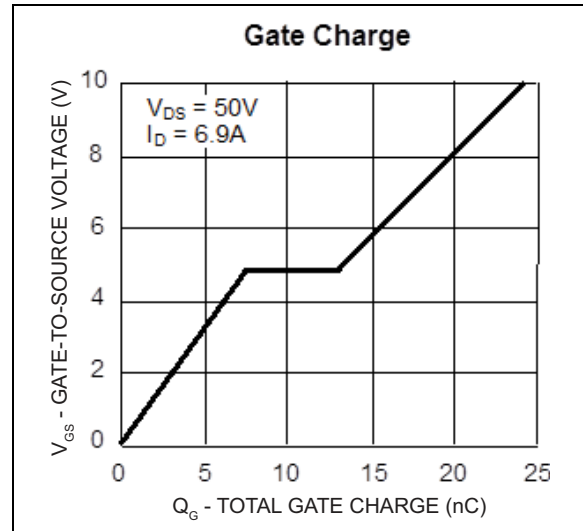

FIGURE 7-8: Typical Gate Charge vs. V_{GS} .

The same energy is dissipated by R_{OFF} , R_G and R_{G_FET} when the driver IC turns the MOSFET off. Assuming R_{ON} is approximately equal to R_{OFF} , the total energy and power dissipated by the resistive drive elements is:

EQUATION 7-7:

$$E_{DRIVER} = Q_G \times V_{GS}$$

Where:

E_{DRIVER} = Energy Dissipated per Switching Cycle

and

EQUATION 7-8:

$$P_{DRIVER} = Q_G \times V_{GS} \times f_S$$

Where:

P_{DRIVER} = Power Dissipated per Switching Cycle

Q_G = Total Gate Charge at V_{GS}

V_{GS} = Gate-to-Source Voltage on the MOSFET

f_S = Switching Frequency of the Gate Drive Circuit

MIC4606

The power dissipated in the driver equals the ratio of R_{ON} and R_{OFF} to the external resistive losses in R_G and R_{G_FET} . Letting $R_{ON} = R_{OFF}$, the power dissipated in the driver due to driving the external MOSFET is:

EQUATION 7-9:

$$P_{diss_driver} = P_{DRIVER} \times \frac{R_{ON}}{R_{ON} + R_G + R_{G_FET}}$$

There are four MOSFETs driven by the MIC4606. The power dissipation for each of the drivers must be calculated and summed to obtain the total driver diode power dissipation for the package.

In some cases, the high-side FET of one phase may be pulsed at a frequency, f_S , while the low-side FET of the other phase is kept continuously on. Since the MOSFET gate is capacitive, there is no driver power if the FET is not switched. The operation of each of the four drivers must be considered to accurately calculate power dissipation.

7.7 Supply Current Power Dissipation

Power is dissipated in the input and control sections of the MIC4606, even if there is no external load. Current is still drawn from the V_{DD} and HB pins for the internal circuitry, the level-shifting circuitry and shoot-through current in the output drivers. The V_{DD} and HB currents are proportional to the operating frequency and the V_{DD} and V_{HB} voltages. The typical characteristic graphs show how supply current varies with switching frequency and supply voltage.

The power dissipated by the MIC4606 due to supply current is:

EQUATION 7-10:

$$P_{diss_supply} = V_{DD} \times I_{DD} + V_{HB} \times I_{HB}$$

Values for I_{DD} and I_{HB} are found in the [Electrical Characteristics](#) tables and the [Typical Performance Curves](#) graphs.

7.8 Total Power Dissipation and Thermal Considerations

Total power dissipation in the MIC4606 is equal to the power dissipation caused by driving the external MOSFETs, the supply currents and the internal bootstrap diodes.

EQUATION 7-11:

$$P_{diss_total} = P_{diss_supply} + P_{diss_drive} + P_{DIODE}$$

The die temperature can be calculated after the total power dissipation is known.

EQUATION 7-12:

$$T_J = T_A + P_{DISStotal} \times \theta_{JA}$$

Where:

T_A = Maximum Ambient Temperature

T_J = Junction Temperature

$P_{DISStotal}$ = Total Power Dissipation

θ_{JA} = Thermal Resistance from Junction to Ambient Air

7.9 Other Timing Considerations

Make sure the input signal pulse width is greater than the minimum specified pulse width. An input signal that is less than the minimum pulse width may result in no output pulse or an output pulse whose width is significantly less than the input.

The maximum duty cycle (ratio of high-side on-time to switching period) is controlled by the minimum pulse width of the low side and by the time required for the C_B capacitor to charge during the off-time. Adequate time must be allowed for the C_B capacitor to charge up before the high-side driver is turned on.

7.10 Decoupling and Bootstrap Capacitor Selection

Decoupling capacitors are required for both the low-side (V_{DD}) and high-side (HB) supply pins. These capacitors supply the charge necessary to drive the external MOSFETs and also minimize the voltage ripple on these pins. The capacitor from HB to HS has two functions: it provides decoupling for the high-side circuitry and also provides current to the high-side circuit while the high-side external MOSFET is on. Ceramic capacitors are recommended because of their low-impedance and small size. Z5U-type ceramic capacitor dielectrics are not recommended because of the large change in capacitance over temperature and voltage. A minimum value of 0.1 μ F is required for C_B (HB to HS capacitors) and 1 μ F for the V_{DD} capacitor, regardless of the MOSFETs being driven. Larger MOSFETs may require larger capacitance values for proper operation.

The voltage rating of the capacitors depends on the supply voltage, ambient temperature and the voltage derating used for reliability. 25V rated X5R or X7R ceramic capacitors are recommended for most applications. The minimum capacitance value should be increased if low-voltage capacitors are used because even good quality dielectric capacitors, such as X5R, will lose 40% to 70% of their capacitance value at the rated voltage.

Placement of the decoupling capacitors is critical. The bypass capacitor for V_{DD} should be placed as close as possible between the V_{DD} and V_{SS} pins. The bypass capacitor (C_B) for the HB supply pin must be located as close as possible between the HB and HS pins. The etch connections must be short, wide and direct. The use of a ground plane to minimize connection impedance is recommended. Refer to **Section 7.13 “Grounding, Component Placement and Circuit Layout”** for more information.

The voltage on the bootstrap capacitor drops each time it delivers charge to turn on the MOSFET. The voltage drop depends on the gate charge required by the MOSFET. Most MOSFET specifications specify gate charge versus V_{GS} voltage. Based on this information, and a recommended ΔV_{HB} of less than 0.1V, the minimum value of bootstrap capacitance is calculated as:

EQUATION 7-13:

$$C_B \geq \frac{Q_{GATE}}{\Delta V_{HB}}$$

Where:

Q_{GATE} = Total Gate Charge at V_{HB}
 ΔV_{HB} = Voltage Drop at the HB Pin

If the high-side MOSFET is not switched, but held in an ON state, the voltage in the bootstrap capacitor will drop due to leakage current that flows from the HB pin to ground. This current is specified in the **Electrical Characteristics** table. In this case, the value of C_B is calculated as:

EQUATION 7-14:

$$C_B \geq \frac{I_{HBS} \times t_{ON}}{\Delta V_{HB}}$$

Where:

I_{HBS} = Maximum HB Pin Leakage Current
 t_{ON} = Maximum High-Side FET On-Time

The larger value of C_B from [Equation 7-13](#) or [7-14](#) should be used.

7.11 DC Motor Applications

MIC4606 MOSFET drivers are widely used in DC motor applications. They address both stepper and brushed motors in full-bridge topologies. As shown in [Figure 7-9](#) and [Figure 7-10](#), the driver switches the MOSFETs at variable duty cycles that modulate the voltage to control motor speed. The full-bridge topology allows for bidirectional control.

The MIC4606's 85V operating voltage offers ample operating voltage margin to protect against voltage spikes in the motor drive circuitry. It is good practice to have at least twice the HV voltage of the motor supply. The MIC4606's 85V operating voltage allows sufficient margin for 12V, 24V and 40V motors.

The MIC4606 is offered in a small 4 mm x 4 mm 16-lead QFN package for applications that are space constrained. The motor trend is to put the motor control circuit inside the motor casing, which requires small packaging because of the size of the motor.

The MIC4606 offers low UVLO threshold and programmable gate drive, which allows for longer operation time in battery-operated motors, such as power hand tools.

MIC4606

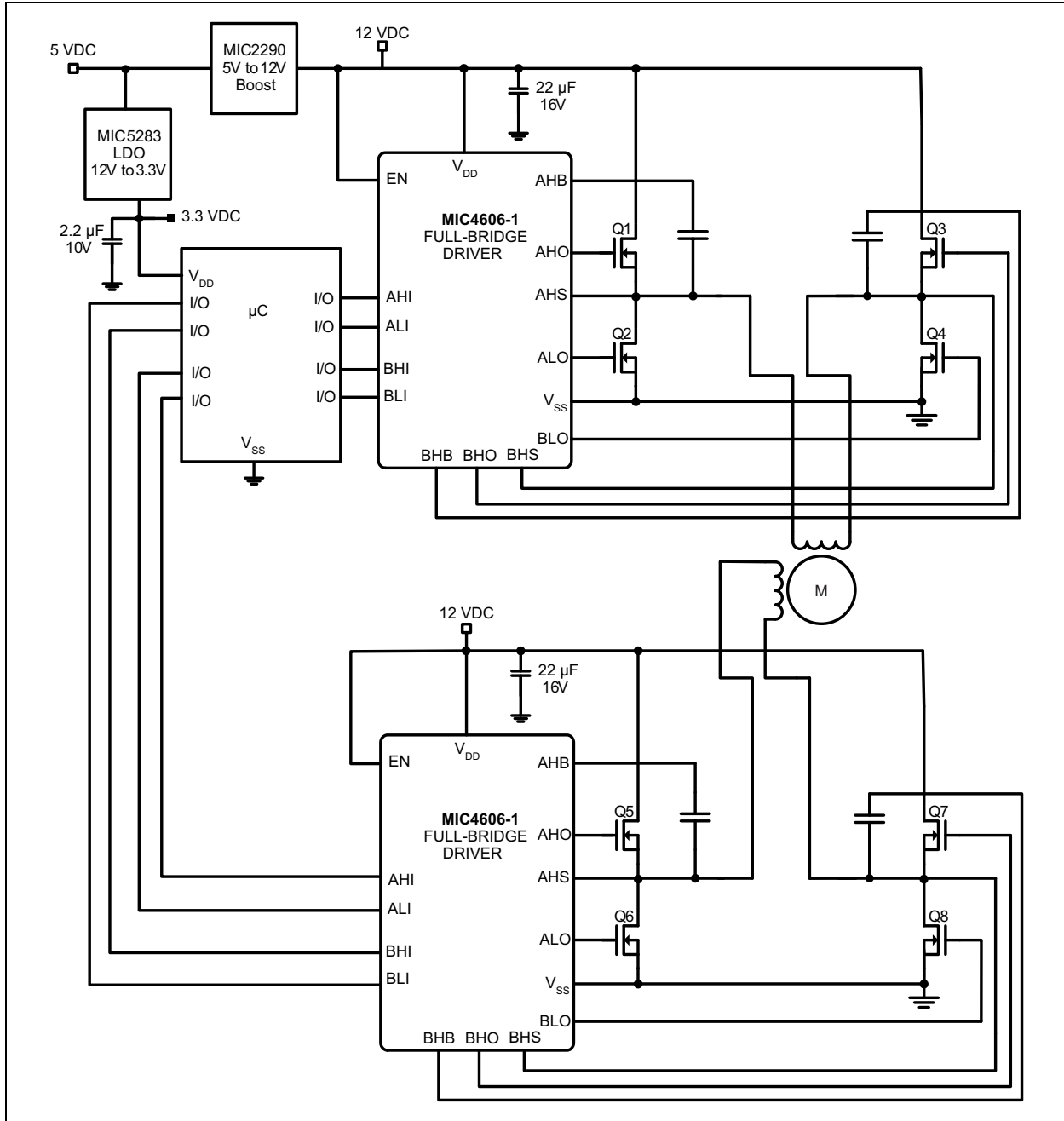

FIGURE 7-9: Stepper Motor Driver.

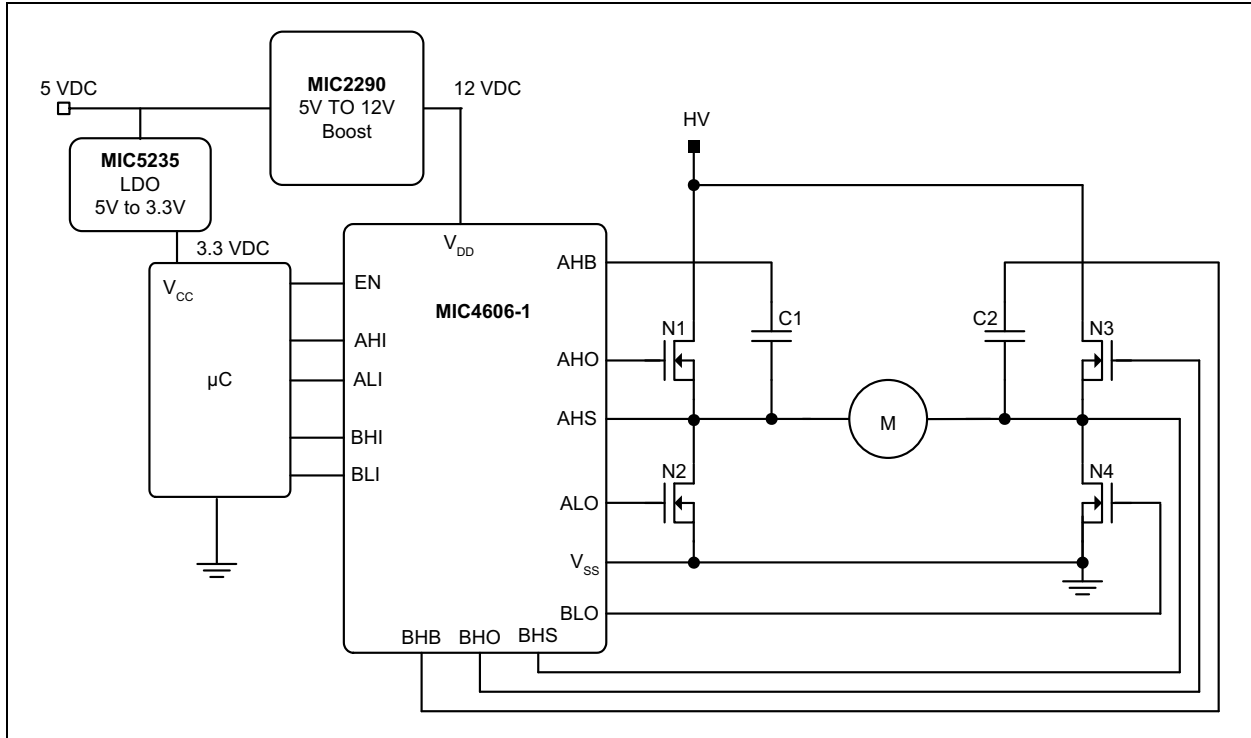

FIGURE 7-10: Full-Bridge DC Motor.

7.12 Power Inverter

Power inverters are used to supply AC loads from a DC operated battery system, mainly during power failure. The battery voltage can be 12 VDC, 24 VDC or up to 36 VDC, depending on the power requirements. There are two popular conversion methods: Type I and Type II that convert the battery energy to AC line voltage (110 VAC or 230 VAC).

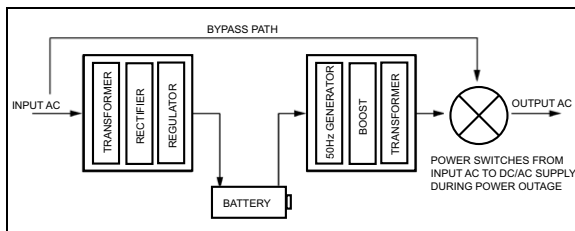

FIGURE 7-11: Type I Inverter Topology.

As shown in Figure 7-11, Type I is a dual stage topology, where line voltage is converted to DC through a transformer to charge the storage batteries. When a power failure is detected, the stored DC energy is converted to AC through another transformer to drive the AC loads connected to the inverter output. This method is simplest to design, but tends to be bulky and expensive because it uses two transformers.

Type II is a single-stage topology that uses only one transformer to charge the bank of batteries to store the energy. During a power outage, the same transformer is used to power the line voltage. The Type II topology switches at a higher frequency as compared to the Type I topology to maintain a small transformer size.

Both types use a full-bridge topology to invert DC to AC. The MIC4606's operating voltage offers enough of a margin to address all of the available banks of batteries commonly used in inverter applications. The 85V operating voltage allows designers to increase the bank of batteries up to 72V, if desired. The MIC4606 can sink as much as 1A, which is sufficient to drive the MOSFET's gate capacitance while switching the MOSFET up to 50 kHz. This makes the MIC4606 an ideal solution for single-phase inverter applications.

7.13 Grounding, Component Placement and Circuit Layout

Nanosecond switching speeds and ampere peak currents in and around the MIC4606 driver require proper placement and trace routing of all components. Improper placement may cause degraded noise immunity, false switching, excessive ringing or circuit latch-up.

Figure 7-12 shows the critical current paths of the high and low-side driver when their outputs go high and turn on the external MOSFETs. It also helps demonstrate the need for a low-impedance ground plane. Charge needed to turn on the MOSFET gates comes from the decoupling capacitors, C_{VDD} and C_B . Current in the low-side gate driver flows from C_{VDD} through the internal driver, into the MOSFET gate, and out the source. The return connection back to the decoupling capacitor is made through the ground plane. Any inductance or resistance in the ground return path causes a voltage spike or ringing to appear on the source of the MOSFET. This voltage works against the gate drive voltage and can either slow down or turn off the MOSFET during the period when it should be turned on.

Current in the high-side driver is sourced from capacitor C_B , and flows into the xHB pin and out the xHO pin, into the gate of the high-side MOSFET. The return path for the current is from the source of the MOSFET and back to capacitor C_B . The high-side circuit return path usually does not have a low-impedance ground plane, so the etch connections in this critical path should be short and wide to minimize parasitic inductance. As with the low-side circuit, impedance between the MOSFET source and the decoupling capacitor causes negative voltage feedback that fights the turn-on of the MOSFET.

It is important to note that capacitor C_B must be placed close to the xHB and xHS pins. This capacitor not only provides all the energy for turn-on, but it must also keep xHB pin noise and ripple low for proper operation of the high-side drive circuitry.

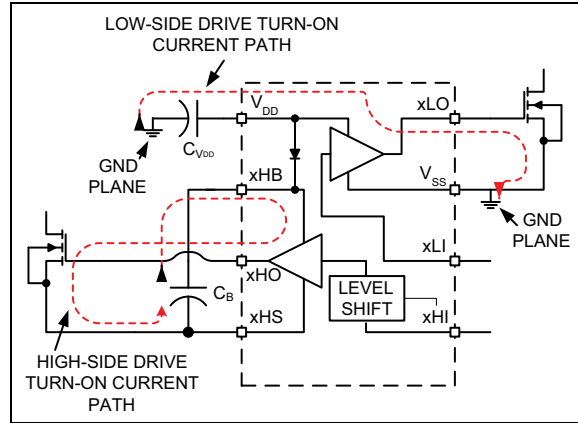

FIGURE 7-12: Turn-On Current Paths.

Figure 7-13 shows the critical current paths when the driver outputs go low and turn off the external MOSFETs. Short, low-impedance connections are important during turn-off for the same reasons given in the turn-on explanation. Current flowing through the internal diode replenishes charge in the bootstrap capacitor, C_B .

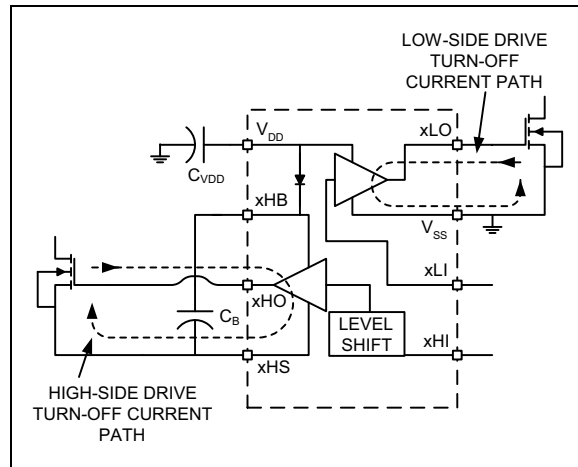
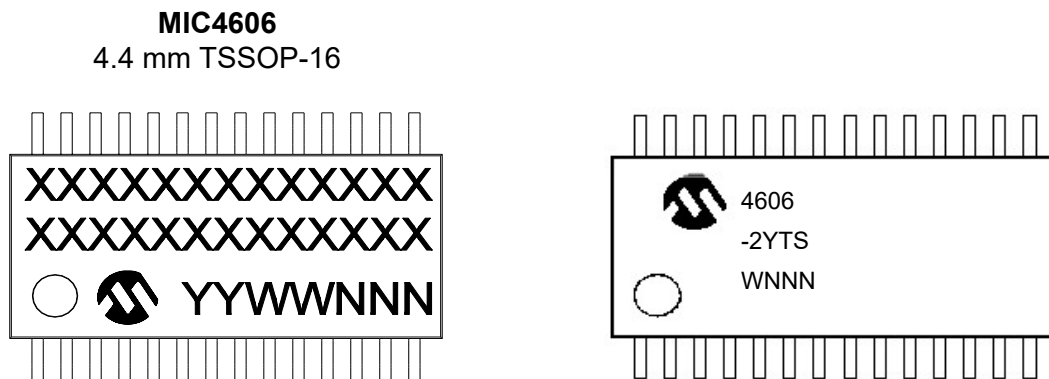
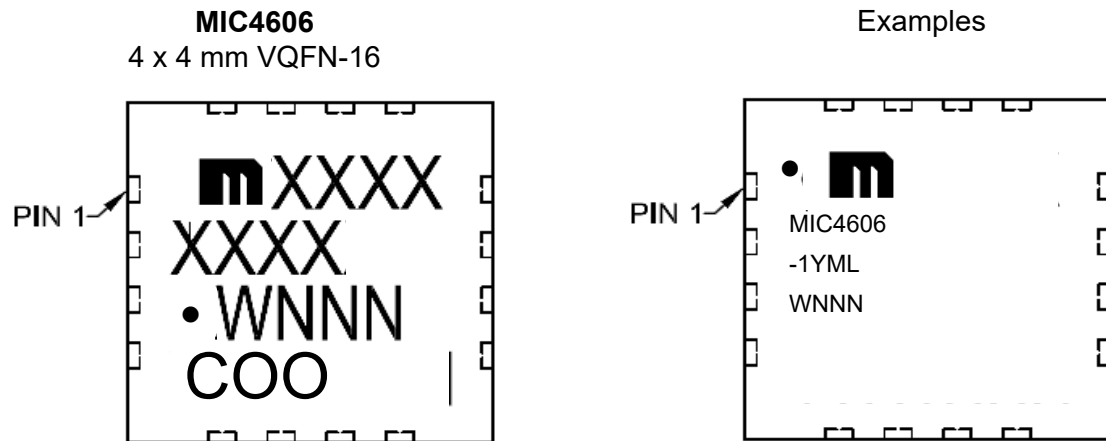

FIGURE 7-13: Turn-Off Current Paths.

8.0 PACKAGING INFORMATION

8.1 Package Marking Information



Legend:	XX...X	Product code or customer-specific information
	Y	Year code (last digit of calendar year)
	YY	Year code (last 2 digits of calendar year)
	WW	Week code (week of January 1 is week '01')
	NNN	Alphanumeric traceability code
	(e3)	Pb-free JEDEC® designator for Matte Tin (Sn)
	*	This package is Pb-free. The Pb-free JEDEC designator (e3) can be found on the outer packaging for this package.
	•, ▲, ▼	Pin one index is identified by a dot, delta up, or delta down (triangle mark).
Note:	In the event the full Microchip part number cannot be marked on one line, it will be carried over to the next line, thus limiting the number of available characters for customer-specific information. Package may or may not include the corporate logo.	
	Underbar (_) and/or Overbar (¯) symbol may not be to scale.	

MIC4606

16-Lead Very Thin Plastic Quad Flat, No Lead Package (NUA) - 4x4 mm Body [VQFN] With 2.35 mm Exposed Pad; Micrel Legacy Package MLF44Q-16L

Note: For the most current package drawings, please see the Microchip Packaging Specification located at <http://www.microchip.com/packaging>

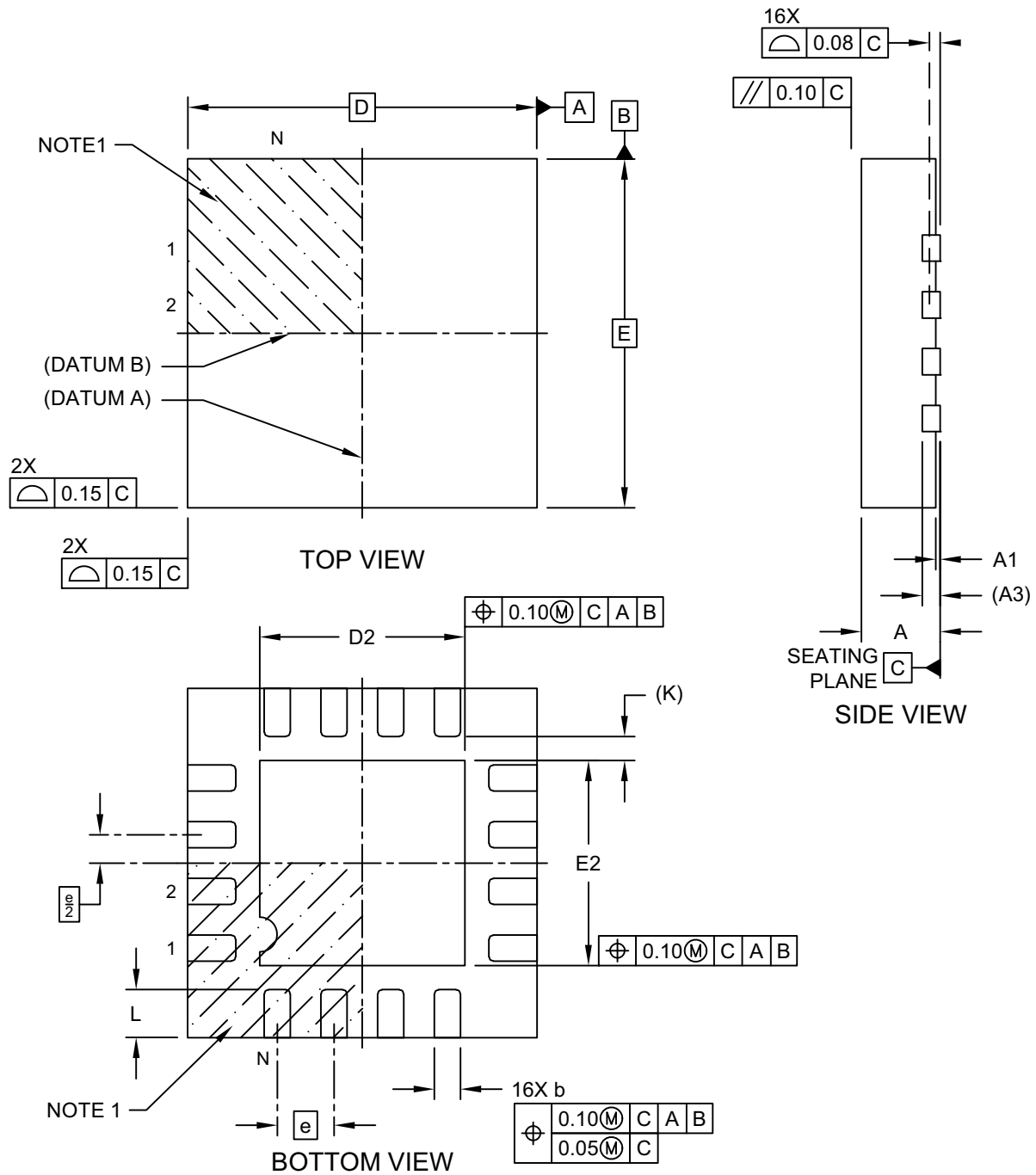

Microchip Technology Drawing C04-1110-NUA Rev A Sheet 1 of 2

16-Lead Very Thin Plastic Quad Flat, No Lead Package (NUA) - 4x4 mm Body [VQFN] With 2.35 mm Exposed Pad; Micrel Legacy Package MLF44Q-16L

Note: For the most current package drawings, please see the Microchip Packaging Specification located at <http://www.microchip.com/packaging>

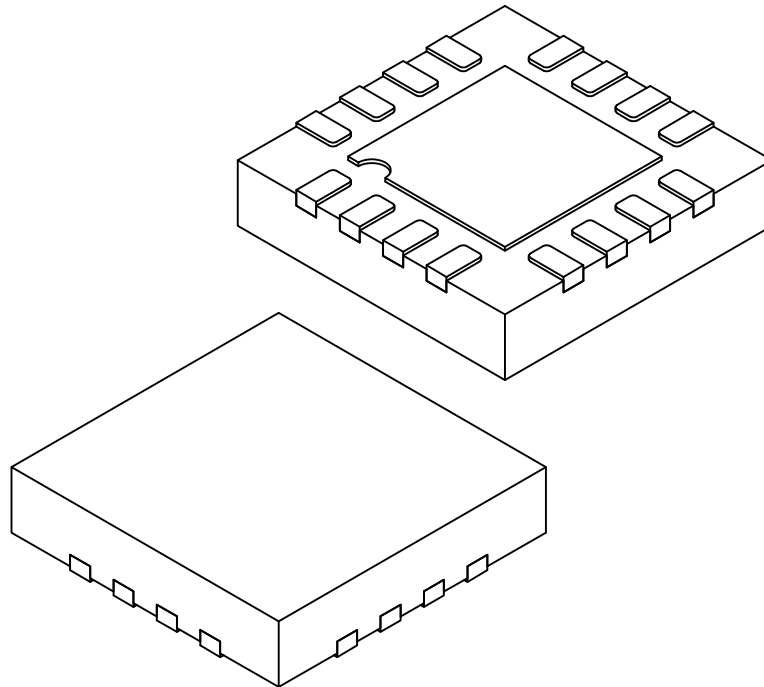

Dimension Limits	Units	MILLIMETERS		
		MIN	NOM	MAX
Number of Terminals	N	16		
Pitch	e	0.65 BSC		
Overall Height	A	0.80	0.85	0.90
Standoff	A1	0.00	0.02	0.05
Terminal Thickness	A3	0.203 REF		
Overall Length	D	4.00 BSC		
Exposed Pad Length	D2	2.30	2.35	2.40
Overall Width	E	4.00 BSC		
Exposed Pad Width	E2	2.30	2.35	2.40
Terminal Width	b	0.25	0.30	0.35
Terminal Length	L	0.50	0.55	0.60
Terminal-to-Exposed-Pad	K	0.28 REF		

Notes:

- Pin 1 visual index feature may vary, but must be located within the hatched area.
- Package is saw singulated
- Dimensioning and tolerancing per ASME Y14.5M
 BSC: Basic Dimension. Theoretically exact value shown without tolerances.
 REF: Reference Dimension, usually without tolerance, for information purposes only.

Microchip Technology Drawing C04-1110-NUA Rev A Sheet 2 of 2

MIC4606

16-Lead Very Thin Plastic Quad Flat, No Lead Package (NUA) - 4x4 mm Body [VQFN] With 2.35 mm Exposed Pad; Micrel Legacy Package MLF44Q-16L

Note: For the most current package drawings, please see the Microchip Packaging Specification located at <http://www.microchip.com/packaging>

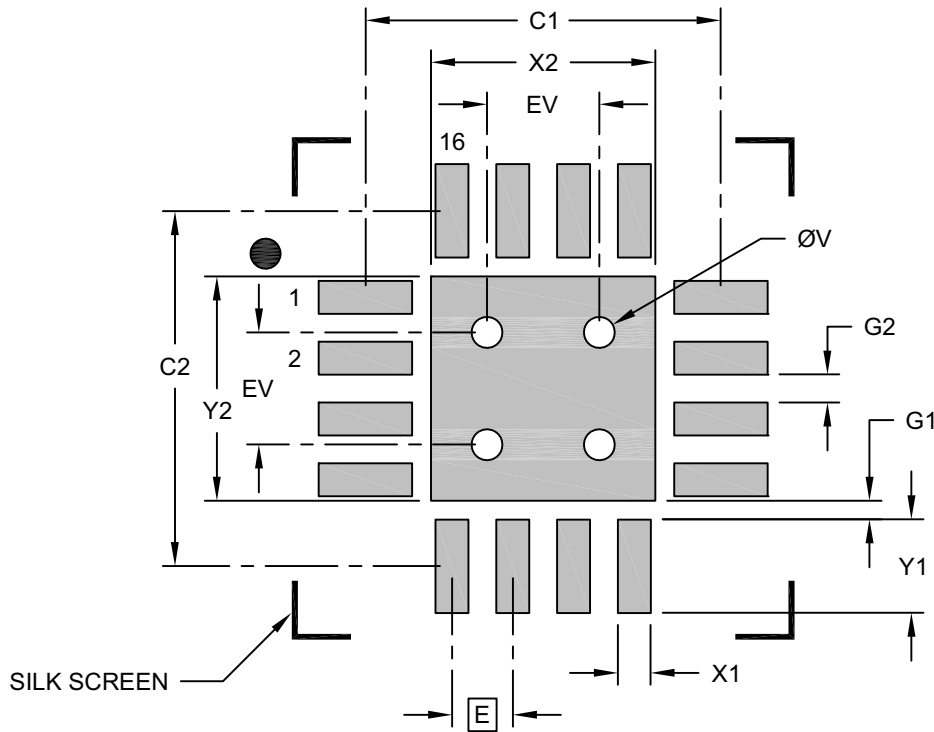

RECOMMENDED LAND PATTERN

Dimension Limits	Units	MILLIMETERS		
		MIN	NOM	MAX
Contact Pitch	E	0.65 BSC		
Center Pad Width	X2			2.40
Center Pad Length	Y2			2.40
Contact Pad Spacing	C1		3.80	
Contact Pad Spacing	C2		3.80	
Contact Pad Width (Xnn)	X1			0.35
Contact Pad Length (Xnn)	Y1			1.00
Contact Pad to Center Pad (Xnn)	G1	0.20		
Contact Pad to Contact Pad (Xnn)	G2	0.30		
Thermal Via Diameter	V		0.33	
Thermal Via Pitch	EV		0.20	

Notes:

1. Dimensioning and tolerancing per ASME Y14.5M
BSC: Basic Dimension. Theoretically exact value shown without tolerances.
2. For best soldering results, thermal vias, if used, should be filled or tented to avoid solder loss during reflow process

Microchip Technology Drawing C04-3110-NUA Rev A

16-Lead Plastic Thin Shrink Small Outline (ST) – 4.4 mm Body [TSSOP]

Note: For the most current package drawings, please see the Microchip Packaging Specification located at <http://www.microchip.com/packaging>

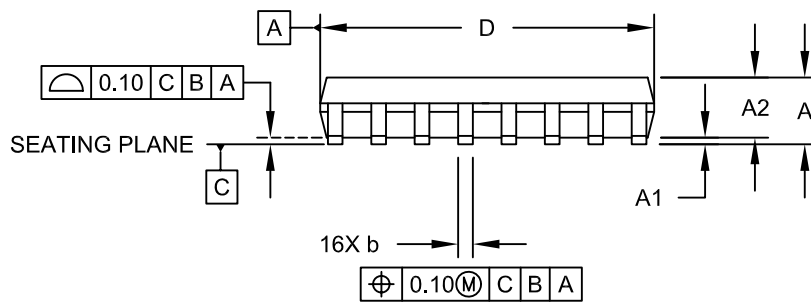
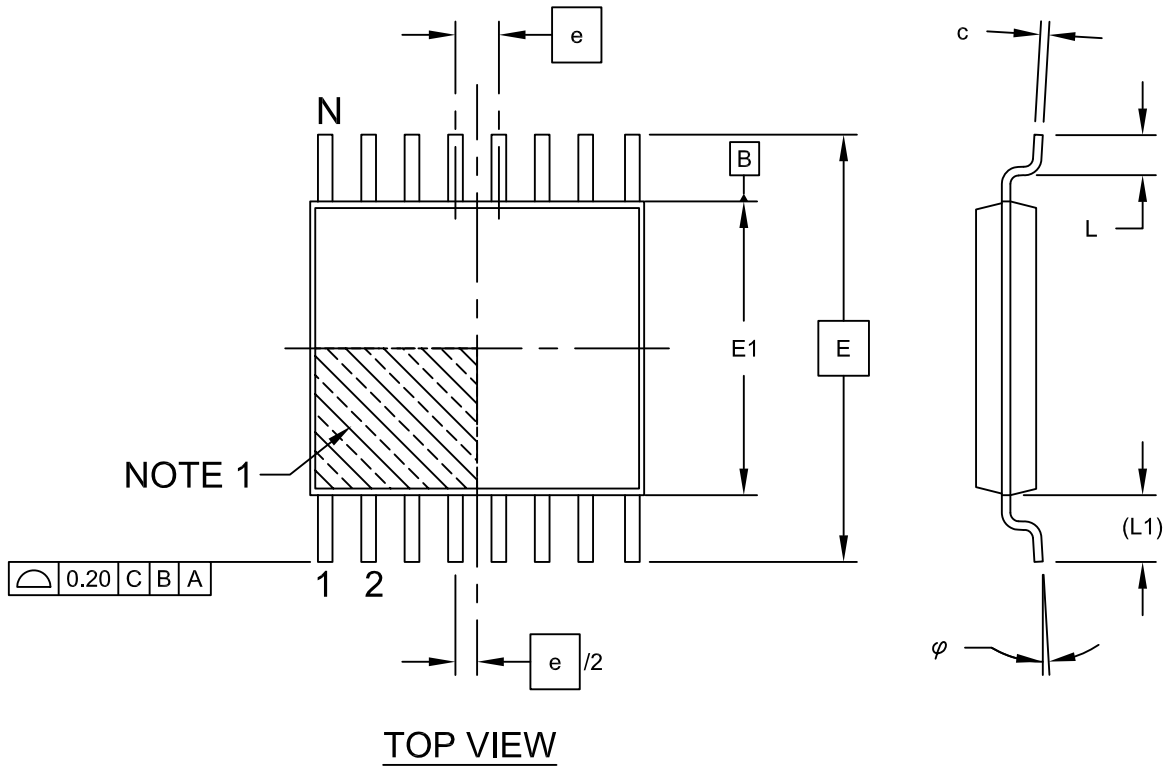

MIC4606

16-Lead Plastic Thin Shrink Small Outline (ST) – 4.4 mm Body [TSSOP]

Note: For the most current package drawings, please see the Microchip Packaging Specification located at <http://www.microchip.com/packaging>

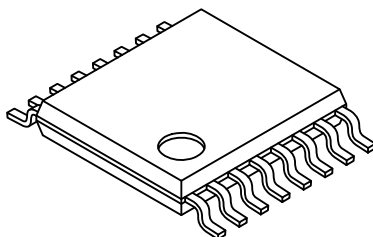

Dimension Limits	Units	MILLIMETERS		
		MIN	NOM	MAX
Number of Pins	N	16		
Pitch	e	0.65 BSC		
Overall Height	A	-	-	1.20
Molded Package Thickness	A2	0.80	1.00	1.05
Standoff	A1	0.05	-	0.15
Overall Width	E	6.40 BSC		
Molded Package Width	E1	4.30	4.40	4.50
Molded Package Length	D	4.90	5.00	5.10
Foot Length	L	0.45	0.60	0.75
Footprint	(L1)	1.00 REF		
Foot Angle	ϕ	0°	-	8°
Lead Thickness	c	0.09	-	0.20
Lead Width	b	0.19	-	0.30

Notes:

1. Pin 1 visual index feature may vary, but must be located within the hatched area.
2. Dimensions D and E1 do not include mold flash or protrusions. Mold flash or protrusions shall not exceed 0.15mm per side.
3. Dimensioning and tolerancing per ASME Y14.5M

BSC: Basic Dimension. Theoretically exact value shown without tolerances.

REF: Reference Dimension, usually without tolerance, for information purposes only.

Microchip Technology Drawing C04-068A Sheet 2 of 2

16-Lead Plastic Thin Shrink Small Outline (ST) – 4.4 mm Body [TSSOP]

Note: For the most current package drawings, please see the Microchip Packaging Specification located at <http://www.microchip.com/packaging>

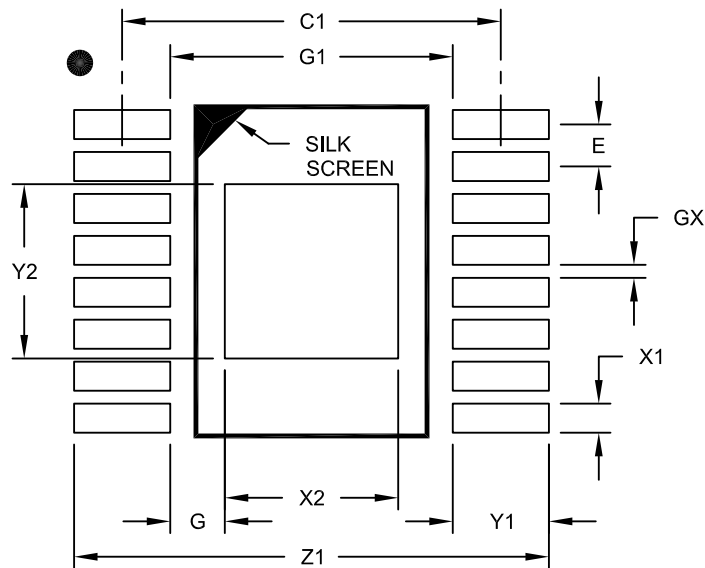

RECOMMENDED LAND PATTERN

Dimension Limits	Units	MILLIMETERS		
		MIN	NOM	MAX
Contact Pitch	E	0.65 BSC		
Optional Center Pad Length	Y2			2.70
Optional Center Pad Width	X2			2.70
Clearance Between Contact Pads	G1	4.40		
Contact Pad To Center Pad	G	0.73		
Contact Pad Spacing	C1		5.90	
Contact Pad Width (X16)	X1			0.45
Contact Pad Length (X16)	Y1			1.50
Distance Between Pads	GX	0.20		
Overall Width	Z1			7.40

Notes:

1. Dimensioning and tolerancing per ASME Y14.5M

BSC: Basic Dimension, Theoretically exact value shown without tolerances.

Microchip Technology Drawing No. C04-2068A

APPENDIX A: REVISION HISTORY

Revision E (October 2021)

- Updated the [Functional Description](#).
- Updated [Section 8.0, Packaging Information](#).

Revision D (December 2019)

- Updated the [Typical Application Circuit](#).
- Updated [Figure 7-5](#).
- Updated **Section 7.2 “HS Pin Clamp”**.
- Various typographical edits.

Revision C (June 2019)

- Updated “**Operating Ratings††**”.

Revision B (January 2018)

- Replaced [Figure 7-5](#) with the correct image.

Revision A (February 2017)

- Converted Micrel document MIC4606 to Microchip data sheet template DS20005604A.
- Minor text changes throughout.

MIC4606

NOTES:

PRODUCT IDENTIFICATION SYSTEM

To order or obtain information, e.g., on pricing or delivery, contact your local Microchip representative or sales office.

<u>PART NO.</u>	<u>-X</u>	<u>X</u>	<u>XX</u>	-	<u>XX</u>
Device	Input Option	Junction Temperature Range	Package		Media Type
Device:	MIC4606:	85V Full-Bridge MOSFET Drivers with Adaptive Dead Time and Shoot-Through Protection			
Input Option:	-1	=	Dual inputs		
	-2	=	Single PWM input		
Junction Temperature Range:	Y	=	-40°C to +125°C (RoHS Compliant)		
Package:	ML	=	16-Lead QFN		
	TS	=	16-Lead TSSOP		
Media Type	T5	=	500/Reel		
	TR	=	5000/Reel QFN (ML) Package		
		=	2500/Reel TSSOP (TS) Package		
	<blank>	=	75/Tube QFN (-1YML) Package		

Examples:	
a) MIC4606-1YML:	85V Full-Bridge MOSFET Driver with Adaptive Dead Time and Shoot-Through Protection, Dual Inputs, -40°C to +125°C Junction Temperature Range, 16-Pin QFN, 75/Tube
b) MIC4606-1YML-T5:	85V Full-Bridge MOSFET Driver with Adaptive Dead Time and Shoot-Through Protection, Dual Inputs, -40°C to +125°C Junction Temperature Range, 16-Pin QFN, 500/Reel
c) MIC4606-1YML-TR:	85V Full-Bridge MOSFET Driver with Adaptive Dead Time and Shoot-Through Protection, Dual Inputs, -40°C to +125°C Junction Temperature Range, 16-Pin QFN, 5000/Reel
d) MIC4606-1YTS-T5:	85V Full-Bridge MOSFET Driver with Adaptive Dead Time and Shoot-Through Protection, Dual Inputs, -40°C to +125°C Junction Temperature Range, 16-Pin TSSOP, 500/Reel
e) MIC4606-1YTS-TR:	85V Full-Bridge MOSFET Driver with Adaptive Dead Time and Shoot-Through Protection, Dual Inputs, -40°C to +125°C Junction Temperature Range, 16-Pin TSSOP, 2500/Reel
f) MIC4606-2YML-T5:	85V Full-Bridge MOSFET Driver with Adaptive Dead Time and Shoot-Through Protection, Single PWM Input, -40°C to +125°C Junction Temperature Range, 16-Pin QFN, 500/Reel
g) MIC4606-2YML-TR:	85V Full-Bridge MOSFET Driver with Adaptive Dead Time and Shoot-Through Protection, Single PWM Input, -40°C to +125°C Junction Temperature Range, 16-Pin QFN, 5000/Reel.

MIC4606

NOTES:

Note the following details of the code protection feature on Microchip products:

- Microchip products meet the specifications contained in their particular Microchip Data Sheet.
- Microchip believes that its family of products is secure when used in the intended manner, within operating specifications, and under normal conditions.
- Microchip values and aggressively protects its intellectual property rights. Attempts to breach the code protection features of Microchip product is strictly prohibited and may violate the Digital Millennium Copyright Act.
- Neither Microchip nor any other semiconductor manufacturer can guarantee the security of its code. Code protection does not mean that we are guaranteeing the product is “unbreakable”. Code protection is constantly evolving. Microchip is committed to continuously improving the code protection features of our products.

This publication and the information herein may be used only with Microchip products, including to design, test, and integrate Microchip products with your application. Use of this information in any other manner violates these terms. Information regarding device applications is provided only for your convenience and may be superseded by updates. It is your responsibility to ensure that your application meets with your specifications. Contact your local Microchip sales office for additional support or, obtain additional support at <https://www.microchip.com/en-us/support/design-help/client-support-services>.

THIS INFORMATION IS PROVIDED BY MICROCHIP "AS IS". MICROCHIP MAKES NO REPRESENTATIONS OR WARRANTIES OF ANY KIND WHETHER EXPRESS OR IMPLIED, WRITTEN OR ORAL, STATUTORY OR OTHERWISE, RELATED TO THE INFORMATION INCLUDING BUT NOT LIMITED TO ANY IMPLIED WARRANTIES OF NON-INFRINGEMENT, MERCHANTABILITY, AND FITNESS FOR A PARTICULAR PURPOSE, OR WARRANTIES RELATED TO ITS CONDITION, QUALITY, OR PERFORMANCE.

IN NO EVENT WILL MICROCHIP BE LIABLE FOR ANY INDIRECT, SPECIAL, PUNITIVE, INCIDENTAL, OR CONSEQUENTIAL LOSS, DAMAGE, COST, OR EXPENSE OF ANY KIND WHATSOEVER RELATED TO THE INFORMATION OR ITS USE, HOWEVER CAUSED, EVEN IF MICROCHIP HAS BEEN ADVISED OF THE POSSIBILITY OR THE DAMAGES ARE FORESEEABLE. TO THE FULLEST EXTENT ALLOWED BY LAW, MICROCHIP'S TOTAL LIABILITY ON ALL CLAIMS IN ANY WAY RELATED TO THE INFORMATION OR ITS USE WILL NOT EXCEED THE AMOUNT OF FEES, IF ANY, THAT YOU HAVE PAID DIRECTLY TO MICROCHIP FOR THE INFORMATION.

Use of Microchip devices in life support and/or safety applications is entirely at the buyer's risk, and the buyer agrees to defend, indemnify and hold harmless Microchip from any and all damages, claims, suits, or expenses resulting from such use. No licenses are conveyed, implicitly or otherwise, under any Microchip intellectual property rights unless otherwise stated.

For information regarding Microchip's Quality Management Systems, please visit www.microchip.com/quality.

Trademarks

The Microchip name and logo, the Microchip logo, Adaptec, AnyRate, AVR, AVR logo, AVR Freaks, BesTime, BitCloud, CryptoMemory, CryptoRF, dsPIC, flexPWR, HELDO, IGLOO, JukeBlox, KeeLoq, Kleer, LANCheck, LinkMD, maXStylus, maXTouch, MediaLB, megaAVR, Microsemi, Microsemi logo, MOST, MOST logo, MPLAB, OptoLyzr, PIC, picoPower, PICSTART, PIC32 logo, PolarFire, Prochip Designer, QTouch, SAM-BA, SenGenuity, SpyNIC, SST, SST Logo, SuperFlash, Symmetricom, SyncServer, Tachyon, TimeSource, tinyAVR, UNI/O, Vectron, and XMEGA are registered trademarks of Microchip Technology Incorporated in the U.S.A. and other countries.

AgileSwitch, APT, ClockWorks, The Embedded Control Solutions Company, EtherSynch, Flashtec, Hyper Speed Control, HyperLight Load, IntelliMOS, Libero, motorBench, mTouch, Powermite 3, Precision Edge, ProASIC, ProASIC Plus, ProASIC Plus logo, QuietWire, SmartFusion, SyncWorld, Temux, TimeCesium, TimeHub, TimePictra, TimeProvider, TrueTime, WinPath, and ZL are registered trademarks of Microchip Technology Incorporated in the U.S.A.

Adjacent Key Suppression, AKS, Analog-for-the-Digital Age, Any Capacitor, AnyIn, AnyOut, Augmented Switching, BlueSky, BodyCom, CodeGuard, CryptoAuthentication, CryptoAutomotive, CryptoCompanion, CryptoController, dsPICDEM, dsPICDEM.net, Dynamic Average Matching, DAM, ECAN, Espresso T1S, EtherGREEN, GridTime, IdealBridge, In-Circuit Serial Programming, ICSP, INICnet, Intelligent Paralleling, Inter-Chip Connectivity, JitterBlocker, Knob-on-Display, maxCrypto, maxView, memBrain, Mindi, MiWi, MPASM, MPF, MPLAB Certified logo, MPLIB, MPLINK, MultiTRAK, NetDetach, NVM Express, NVMe, Omniscient Code Generation, PICDEM, PICDEM.net, PICKit, PICtail, PowerSmart, PureSilicon, QMatrix, REAL ICE, Ripple Blocker, RTAX, RTG4, SAM-ICE, Serial Quad I/O, simpleMAP, SimpliPHY, SmartBuffer, SmartHLS, SMART-I.S., storClad, SQL, SuperSwitcher, SuperSwitcher II, Switchtec, SynchroPHY, Total Endurance, TSHARC, USBCheck, VariSense, VectorBlox, VeriPHY, ViewSpan, WiperLock, XpressConnect, and ZENA are trademarks of Microchip Technology Incorporated in the U.S.A. and other countries.

SQTP is a service mark of Microchip Technology Incorporated in the U.S.A.

The Adaptec logo, Frequency on Demand, Silicon Storage Technology, Symmcom, and Trusted Time are registered trademarks of Microchip Technology Inc. in other countries.

GestIC is a registered trademark of Microchip Technology Germany II GmbH & Co. KG, a subsidiary of Microchip Technology Inc., in other countries.

All other trademarks mentioned herein are property of their respective companies.

© 2021, Microchip Technology Incorporated and its subsidiaries.

All Rights Reserved.

ISBN: 978-1-5224-9042-5



MICROCHIP

Worldwide Sales and Service

AMERICAS

Corporate Office
2355 West Chandler Blvd.
Chandler, AZ 85224-6199
Tel: 480-792-7200
Fax: 480-792-7277
Technical Support:
<http://www.microchip.com/support>
Web Address:
www.microchip.com

Atlanta

Duluth, GA
Tel: 678-957-9614
Fax: 678-957-1455

Austin, TX

Tel: 512-257-3370

Boston

Westborough, MA
Tel: 774-760-0087
Fax: 774-760-0088

Chicago

Itasca, IL
Tel: 630-285-0071
Fax: 630-285-0075

Dallas

Addison, TX
Tel: 972-818-7423
Fax: 972-818-2924

Detroit

Novi, MI
Tel: 248-848-4000

Houston, TX

Tel: 281-894-5983

Indianapolis

Noblesville, IN
Tel: 317-773-8323
Fax: 317-773-5453
Tel: 317-536-2380

Los Angeles

Mission Viejo, CA
Tel: 949-462-9523
Fax: 949-462-9608
Tel: 951-273-7800

Raleigh, NC

Tel: 919-844-7510

New York, NY

Tel: 631-435-6000

San Jose, CA

Tel: 408-735-9110
Tel: 408-436-4270

Canada - Toronto

Tel: 905-695-1980
Fax: 905-695-2078

ASIA/PACIFIC

Australia - Sydney
Tel: 61-2-9868-6733

China - Beijing
Tel: 86-10-8569-7000

China - Chengdu
Tel: 86-28-8665-5511

China - Chongqing
Tel: 86-23-8980-9588

China - Dongguan
Tel: 86-769-8702-9880

China - Guangzhou
Tel: 86-20-8755-8029

China - Hangzhou
Tel: 86-571-8792-8115

China - Hong Kong SAR
Tel: 852-2943-5100

China - Nanjing
Tel: 86-25-8473-2460

China - Qingdao
Tel: 86-532-8502-7355

China - Shanghai
Tel: 86-21-3326-8000

China - Shenyang
Tel: 86-24-2334-2829

China - Shenzhen
Tel: 86-755-8864-2200

China - Suzhou
Tel: 86-186-6233-1526

China - Wuhan
Tel: 86-27-5980-5300

China - Xian
Tel: 86-29-8833-7252

China - Xiamen
Tel: 86-592-2388138

China - Zhuhai
Tel: 86-756-3210040

ASIA/PACIFIC

India - Bangalore
Tel: 91-80-3090-4444

India - New Delhi
Tel: 91-11-4160-8631

India - Pune
Tel: 91-20-4121-0141

Japan - Osaka
Tel: 81-6-6152-7160

Japan - Tokyo
Tel: 81-3-6880-3770

Korea - Daegu
Tel: 82-53-744-4301

Korea - Seoul
Tel: 82-2-554-7200

Malaysia - Kuala Lumpur
Tel: 60-3-7651-7906

Malaysia - Penang
Tel: 60-4-227-8870

Philippines - Manila
Tel: 63-2-634-9065

Singapore
Tel: 65-6334-8870

Taiwan - Hsin Chu
Tel: 886-3-577-8366

Taiwan - Kaohsiung
Tel: 886-7-213-7830

Taiwan - Taipei
Tel: 886-2-2508-8600

Thailand - Bangkok
Tel: 66-2-694-1351

Vietnam - Ho Chi Minh
Tel: 84-28-5448-2100

EUROPE

Austria - Wels
Tel: 43-7242-2244-39
Fax: 43-7242-2244-393

Denmark - Copenhagen
Tel: 45-4485-5910
Fax: 45-4485-2829

Finland - Espoo
Tel: 358-9-4520-820

France - Paris
Tel: 33-1-69-53-63-20
Fax: 33-1-69-30-90-79

Germany - Garching
Tel: 49-8931-9700

Germany - Haan
Tel: 49-2129-3766400

Germany - Heilbronn
Tel: 49-7131-72400

Germany - Karlsruhe
Tel: 49-721-625370

Germany - Munich
Tel: 49-89-627-144-0
Fax: 49-89-627-144-44

Germany - Rosenheim
Tel: 49-8031-354-560

Israel - Ra'anana
Tel: 972-9-744-7705

Italy - Milan
Tel: 39-0331-742611
Fax: 39-0331-466781

Italy - Padova
Tel: 39-049-7625286

Netherlands - Drunen
Tel: 31-416-690399
Fax: 31-416-690340

Norway - Trondheim
Tel: 47-7288-4388

Poland - Warsaw
Tel: 48-22-3325737

Romania - Bucharest
Tel: 40-21-407-87-50

Spain - Madrid
Tel: 34-91-708-08-90
Fax: 34-91-708-08-91

Sweden - Gothenberg
Tel: 46-31-704-60-40

Sweden - Stockholm
Tel: 46-8-5090-4654

UK - Wokingham
Tel: 44-118-921-5800
Fax: 44-118-921-5820