

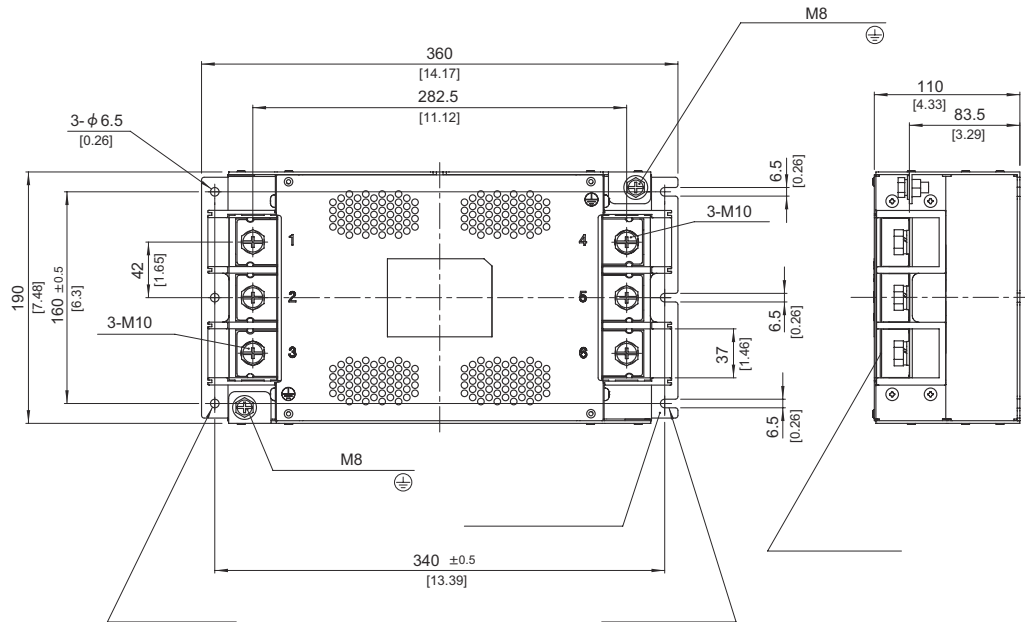

## External view



※ Can not be mounted upside-down.  
(mounted the top surface)

- ※ Tolerance :  $\pm 1$  [ $\pm 0.04$ ]
- ※ Weight : 8.0kg max
- ※ Mounting Plate : Stainless steel  $t=2.0$  [0.08]
- ※ Dimensions in mm, [ ]=inches
- ※ Terminal block screw tightening torque M10 : 14.2N · m (144.9kgf · cm) max
- ※ Protection Earth screw tightening torque M8 : 9.2N · m (93.9kgf · cm) max