

## 600V 3-Phase MOSFET/IGBT Driver

### Features

- Gate Drive Supply Voltage up to 20V
- Overcurrent Protection with Programmable Restart Delay
- 1A Gate Drivers
- Dual (HI/LI) Inputs per Phase
- Fault Signal Asserts on Overcurrent and  $V_{DD}$  UVLO
- TTL Input Thresholds
- 300 ns Typical Input Filtering Time
- Shoot-Through Protection
- Low Power Consumption
- Supply Undervoltage Protection
- $-40^{\circ}\text{C}$  to  $+125^{\circ}\text{C}$  Junction Temperature Range

### Typical Applications

- 3-Phase Motor Drive
- Field-Oriented Control (FOC)
- White Goods Appliances
- Brushless DC Fans

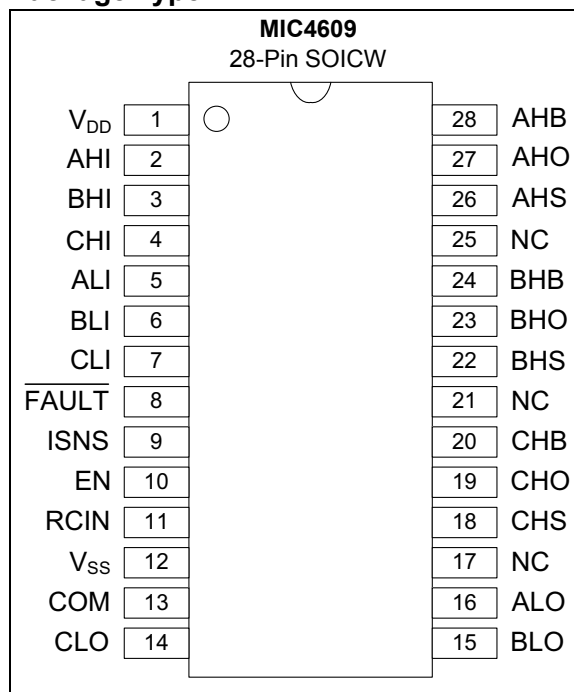
### General Description

The MIC4609 is a 600V 3-phase MOSFET/IGBT driver. The MIC4609 features a 300 ns typical input filtering time to prevent unwanted pulses and a 550 ns of propagation delay. The MIC4609 has TTL input thresholds.

The robust operation of the MIC4609 ensures that the outputs are not affected by supply glitches, High Side (HS) ringing below ground, or HS slewing with high-speed voltage transitions. Undervoltage protection is provided on both the low-side and high-side drivers.

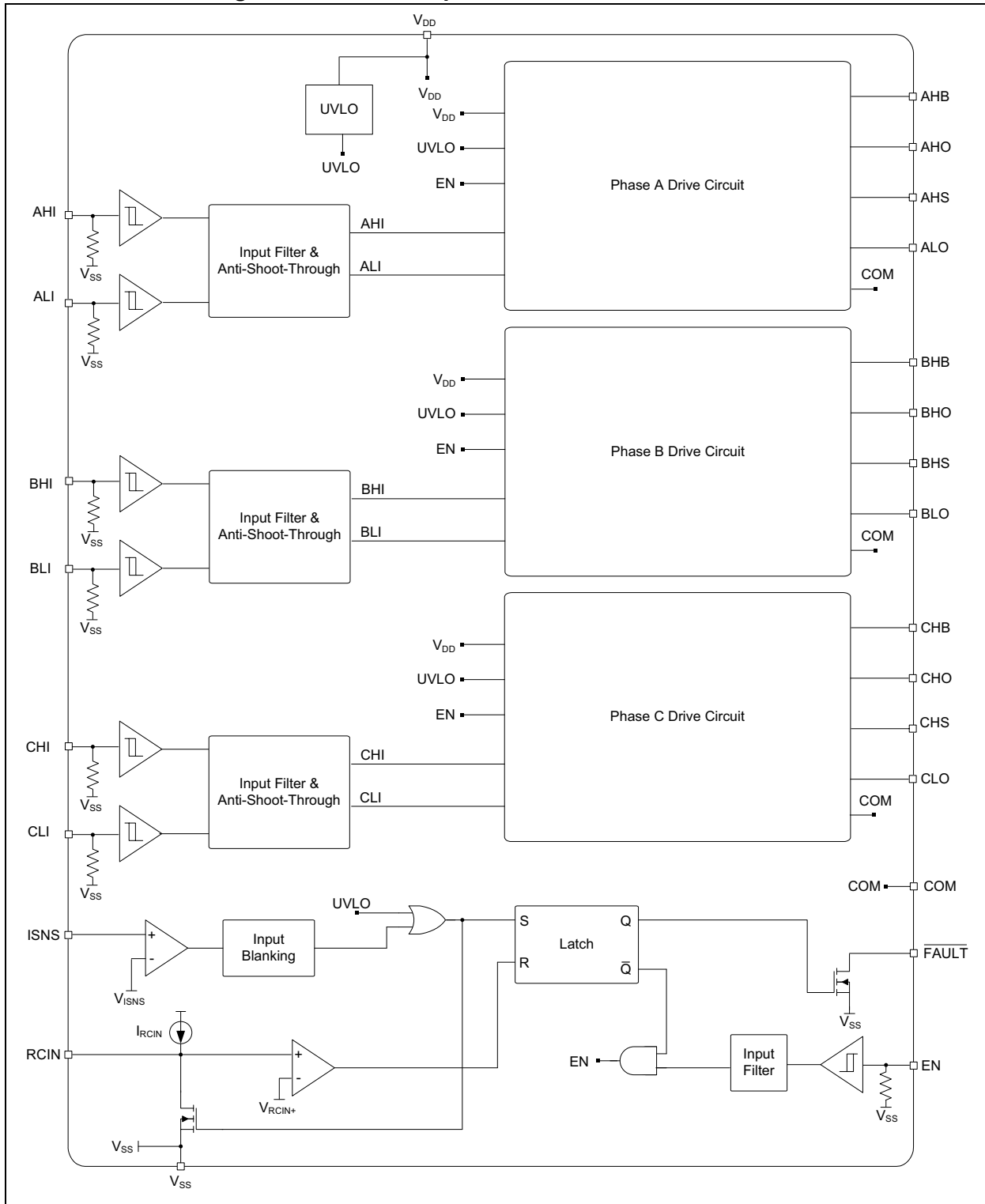
The MIC4609 is available in a 28-pin wide SOIC package. The MIC4609 has an operating junction temperature range of  $-40^{\circ}\text{C}$  to  $+125^{\circ}\text{C}$ .

### Package Type

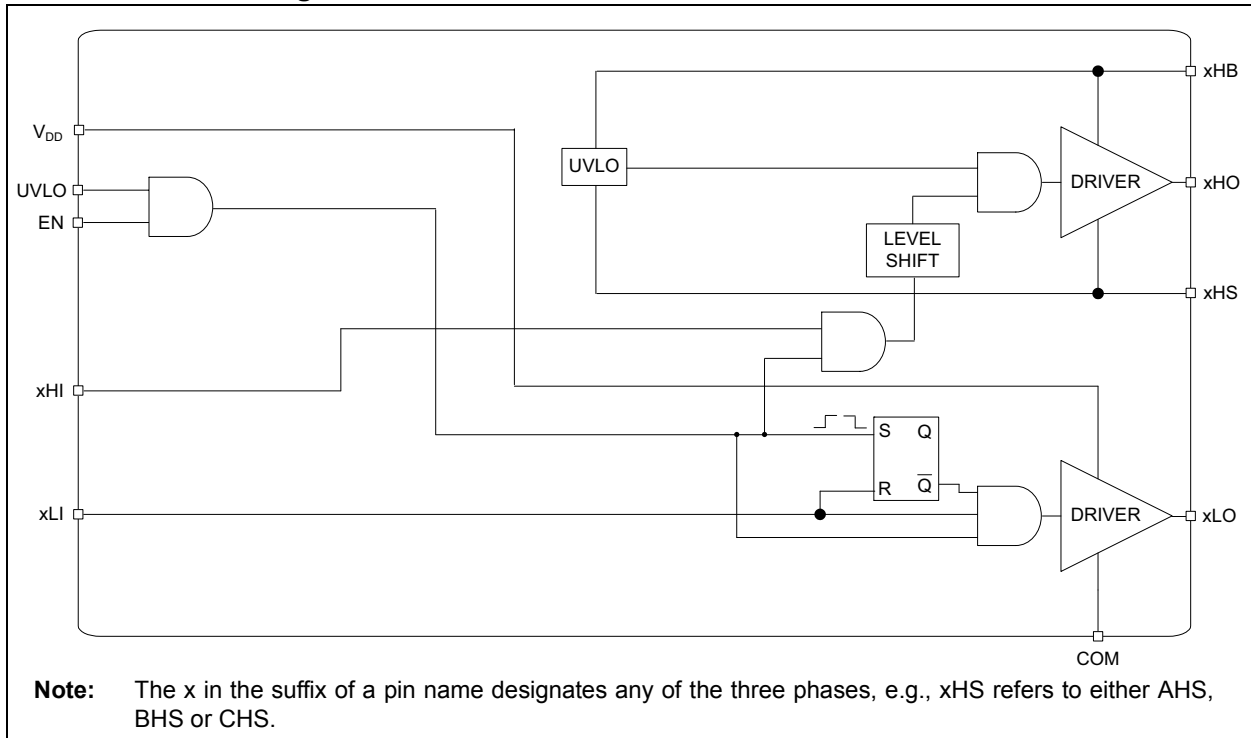


# MIC4609

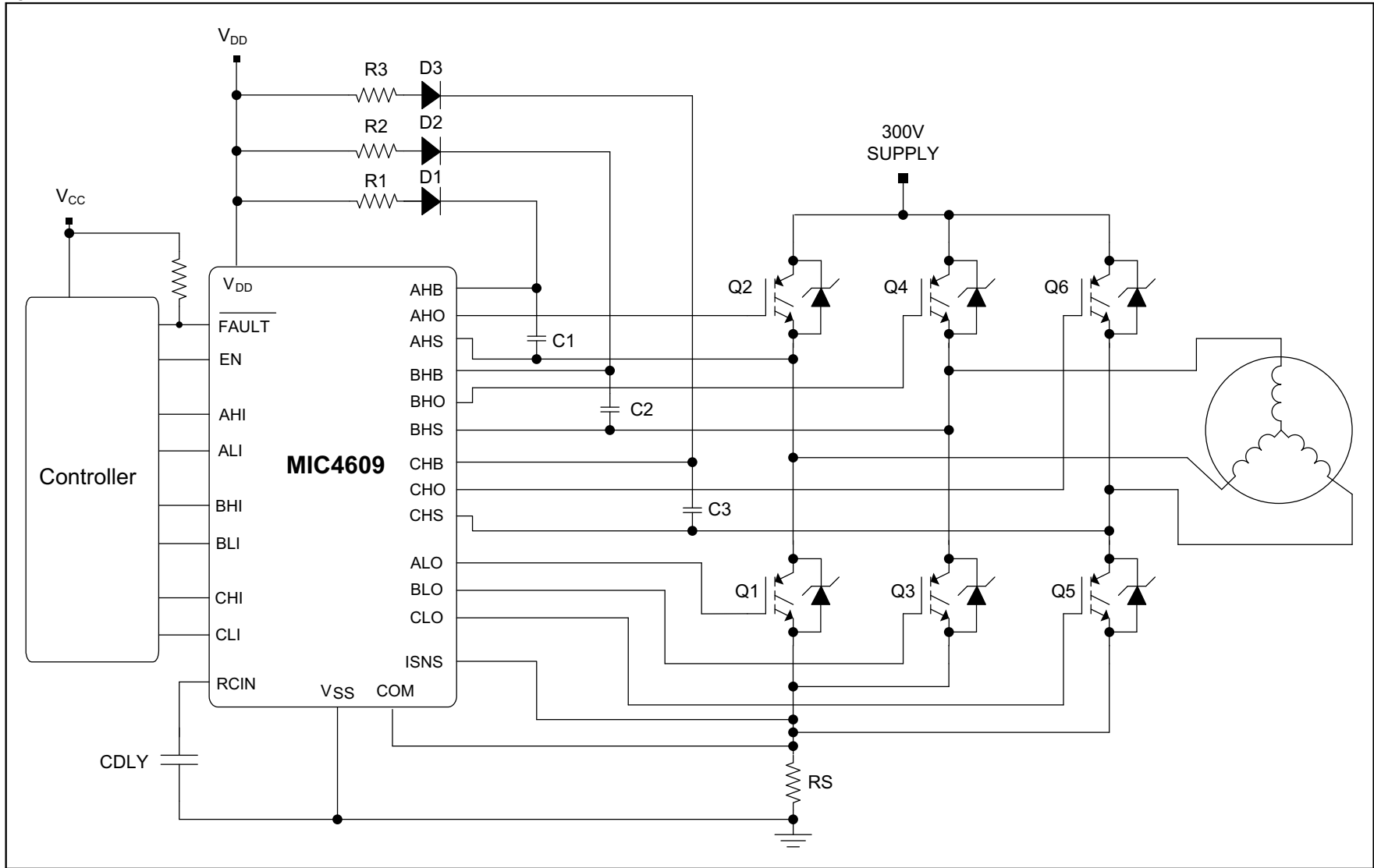
## Functional Block Diagram MIC4609 – Top Level Circuit



## Functional Block Diagram MIC4609 – Phase x Drive Circuit



### Typical Application Circuit MIC4609 – 300V, 3-Phase Motor Driver



## 1.0 ELECTRICAL CHARACTERISTICS

### Absolute Maximum Ratings †

|  |                             |
|--|-----------------------------|
| Supply Voltage ( $V_{DD}$ , $V_{xHB} - V_{xHS}$ ).....   | -0.3V to +25V               |
| Input Voltages ( $V_{xLI}$ , $V_{xHI}$ , $V_{EN}$ )..... | -0.3V to $V_{DD}$           |
| Voltage on LO ( $V_{xLO}$ ).....                         | -0.3V to $V_{DD}$           |
| Voltage on HO ( $V_{xHO}$ ).....                         | $V_{HS} - 0.3V$ to $V_{HB}$ |
| Voltage on HS.....                                       | -5V to +630V                |
| Voltage on HB.....                                       | +655V                       |
| ESD Rating (HBM).....                                    | 2 kV                        |
| ESD Rating (CDM).....                                    | 1.5 kV                      |

### Operating Ratings ‡

|  |                                    |
|--|------------------------------------|
| Supply Voltage ( $V_{DD}$ ).....           | +10V to +20V                       |
| Voltage on xHS (continuous).....           | -1V to +600V                       |
| Voltage on xHS (repetitive transient)..... | -5V to +600V                       |
| HS Slew Rate.....                          | 50 V/ns                            |
| Voltage on xHB.....                        | $V_{xHS} + 10V$ to $V_{xHS} + 20V$ |
| and/or.....                                | $V_{DD} - 1V$ to $V_{DD} + 600V$   |

† **Notice:** Stresses above those listed under “Maximum Ratings” may cause permanent damage to the device. This is a stress rating only and functional operation of the device at those or any other conditions above those indicated in the operational listings of this specification is not implied. Exposure to maximum rating conditions for extended periods may affect device reliability.

‡ **Notice:** The device is not guaranteed to function outside its operating rating.

# MIC4609

## AC/DC ELECTRICAL CHARACTERISTICS (Note 1, 2)

**Electrical Specifications:** Unless otherwise indicated,  $V_{DD} = V_{xHB} = 20V$ ,  $V_{EN} = 5V$ ,  $V_{SS} = V_{xHS} = 0V$ ; No load on xLO or xHO,  $T_A = +25^\circ C$ . **Bold** values indicate  $-40^\circ C \leq T_J \leq +125^\circ C$ .

| Parameter                        | Symbol     | Min.       | Typ. | Max.        | Units     | Conditions                                 |
|----------------------------------|------------|------------|------|-------------|-----------|--|
| <b>Supply Current</b>            |            |            |      |             |           |  |
| $V_{DD}$ Quiescent Current       | $I_{DD}$   | —          | 150  | <b>250</b>  | $\mu A$   | xLI = xHI = 0V                             |
| $V_{DD}$ Shutdown Current        | $I_{DDSH}$ | —          | 0.1  | <b>10</b>   | $\mu A$   | EN = 0V with HS = floating or ground       |
| $V_{DD}$ Operating Current       | $I_{DDO}$  | —          | 240  | <b>350</b>  | $\mu A$   | f = 20 kHz                                 |
| Total xHB Quiescent Current      | $I_{xHB}$  | —          | 81   | <b>180</b>  | $\mu A$   | xLI = xHI = 0V or<br>xLI = 0V and xHI = 5V |
| Total xHB Operating Current      | $I_{xHBO}$ | —          | 600  | <b>1500</b> | $\mu A$   | f = 20 kHz                                 |
| High-Side Leakage Current        | $I_{LxHB}$ | —          | 1    | <b>10</b>   | $\mu A$   | $V_{xHB} = V_{xHS} = 600V$                 |
| <b>Input (TTL: xLI, xHI, EN)</b> |            |            |      |             |           |  |
| Low-Level Input Voltage          | $V_{IL}$   | —          | —    | <b>0.8</b>  | V         |  |
| High-Level Input Voltage         | $V_{IH}$   | <b>2.2</b> | —    | —           | V         |  |
| Input Voltage Hysteresis         | $V_{HYS}$  | —          | 0.2  | —           | V         |  |
| Input Pull-Down Resistance       | $R_I$      | <b>100</b> | 370  | <b>500</b>  | $k\Omega$ | For xLI and xHI only (Note 3)              |
| <b>Undervoltage Protection</b>   |            |            |      |             |           |  |
| $V_{DD}$ Falling Threshold       | $V_{DDR}$  | <b>7</b>   | 8    | <b>9</b>    | V         | —  |
| $V_{DD}$ Threshold Hysteresis    | $V_{DDH}$  | —          | 0.5  | —           | V         | —  |
| xHB Falling Threshold            | $V_{xHBR}$ | <b>7</b>   | 8    | <b>9</b>    | V         | —  |
| xHB Threshold Hysteresis         | $V_{xHBH}$ | —          | 0.5  | —           | V         | —  |

**Note 1:** Specification for packaged product only.

**2:** The x in the suffix of a pin name designates any of the three phases, e.g., xHS refers to either AHS, BHS or CHS.

**3:** Enable resistance is typical only and is not production tested.

## AC/DC ELECTRICAL CHARACTERISTICS (CONTINUED) (Note 1, 2)

**Electrical Specifications:** Unless otherwise indicated,  $V_{DD} = V_{xHB} = 20V$ ,  $V_{EN} = 5V$ ,  $V_{SS} = V_{xHS} = 0V$ ; No load on xLO or xHO,  $T_A = +25^\circ C$ . **Bold** values indicate  $-40^\circ C \leq T_J \leq +125^\circ C$ .

| Parameter                       | Symbol           | Min. | Typ. | Max.       | Units   | Conditions  |
|---------------------------------|------------------|------|------|------------|---------|---|
| <b>Overcurrent Protection</b>   |                  |      |      |            |         |   |
| Rising Overcurrent Threshold    | $V_{ISNS+}$      | 420  | 520  | 650        | mV      | —   |
| ISNS Pin Blanking Time          | $t_{ISNS\_BLK}$  | 270  | 370  | 470        | ns      | —   |
| ISNS-to-Gate Propagation Delay  | $t_{ISNS\_PROP}$ | 400  | 650  | 900        | ns      | —   |
| <b>Fault Circuit</b>            |                  |      |      |            |         |   |
| Fault Pin Output Low Voltage    | $V_{OLF}$        | —    | —    | <b>0.8</b> | V       | $V_{ISNS} = 1V$ , $I_{FAULT} = 1\text{ mA}$                 |
| Rising VCIN Pin Threshold       | $V_{RCIN+}$      | —    | 5    | —          | V       | —   |
| VCIN Hysteresis                 | $V_{RCIN\_HYS}$  | —    | 0.6  | —          | V       | —   |
| RCIN Pin Current Source         | $I_{RCIN}$       | 3    | 5    | 7          | $\mu A$ | $V_{RCIN} = 0V$   |
| Fault Clear Time                | $t_{FCL}$        | 0.5  | 1    | 2          | ms      | $C_{RCIN} = 1nF$  |
| <b>LO Gate Driver</b>           |                  |      |      |            |         |   |
| Low-Level Output Voltage        | $V_{xOLL}$       | —    | 0.5  | <b>0.9</b> | V       | $I_{xLO} = 50\text{ mA}$                                    |
| High-Level Output Voltage       | $V_{xOHL}$       | —    | 0.6  | <b>0.9</b> | V       | $I_{xLO} = -50\text{ mA}$<br>$V_{xOHL} = V_{DD} - V_{xLO}$  |
| Peak Sink Current               | $I_{xOHL}$       | —    | 1    | —          | A       | $V_{xLO} = 0V$  |
| Peak Source Current             | $I_{xOLL}$       | —    | 1    | —          | A       | $V_{xLO} = 20V$   |
| <b>HO Gate Driver</b>           |                  |      |      |            |         |   |
| Low-Level Output Voltage        | $V_{xOLH}$       | —    | 0.5  | <b>0.9</b> | V       | $I_{xHO} = 50\text{ mA}$                                    |
| High-Level Output Voltage       | $V_{xOHH}$       | —    | 0.6  | <b>0.9</b> | V       | $I_{xHO} = -50\text{ mA}$<br>$V_{xOHH} = V_{xHB} - V_{xHO}$ |
| Peak Sink Current               | $I_{xOHH}$       | —    | 1    | —          | A       | $V_{xHO} = 0V$  |
| Peak Source Current             | $I_{xOLH}$       | —    | 1    | —          | A       | $V_{xHO} = 20V$   |
| <b>Switching Specifications</b> |                  |      |      |            |         |   |
| Turn-On Propagation Delay       | $t_{ON}$         | 300  | 600  | 700        | ns      | $C_L = 1\text{ nF}$   |
| Turn-Off Propagation Delay      | $t_{OFF}$        | 300  | 550  | 700        | ns      | $C_L = 1\text{ nF}$   |
| Turn-On Rise Time               | $t_R$            | —    | 20   | 60         | ns      | $C_L = 1\text{ nF}$   |
| Turn-Off Fall Time              | $t_F$            | —    | 20   | 60         | ns      | $C_L = 1\text{ nF}$   |
| Input Filtering Time            | $t_{FLTR}$       | 200  | 300  | 480        | ns      | xLI, xHI, EN  |
| Dead Time                       | $t_D$            | 200  | 300  | 450        | ns      | $C_L = 1\text{ nF}$   |
| Delay Matching                  | $t_{DLYM}$       | —    | 50   | —          | ns      | $C_L = 1\text{ nF}$   |
| EN-to-Gate Shutdown Delay       | $t_{EN\_OFF}$    | 450  | 650  | 750        | ns      | $C_L = 1\text{ nF}$   |
| Output Pulse Width Matching     | $t_{PWN}$        | —    | 50   | —          | ns      | $t_{PW} > 1\text{ }\mu s$<br>$C_L = 1\text{ nF}$            |

**Note 1:** Specification for packaged product only.

**2:** The x in the suffix of a pin name designates any of the three phases, e.g., xHS refers to either AHS, BHS or CHS.

**3:** Enable resistance is typical only and is not production tested.

# MIC4609

---

## TEMPERATURE CHARACTERISTICS

**Electrical Specifications:** Unless otherwise indicated, all parameters apply with  $10V \leq V_{DD} \leq 20V$ .

| Parameters                                    | Symbol        | Min. | Typ. | Max. | Units | Conditions |
|---|---------------|------|------|------|-------|------------|
| <b>Temperature Ranges</b>                     |               |      |      |      |       |            |
| Specified Temperature Range ( <b>Note 1</b> ) | $T_A$         | -40  | —    | +125 | °C    | —          |
| Operating Temperature Range                   | $T_A$         | -40  | —    | +125 | °C    | —          |
| Storage Temperature Range                     | $T_S$         | -60  | —    | +150 | °C    | —          |
| <b>Thermal Package Resistances</b>            |               |      |      |      |       |            |
| Thermal Resistance, 28LD SOICW                | $\theta_{JA}$ | —    | 53   | —    | °C/W  | —          |

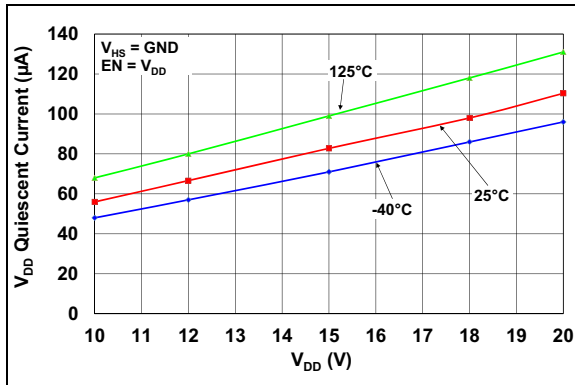
**Note 1:** Operation in this range must not cause  $T_J$  to exceed Maximum Junction Temperature (+125°C).



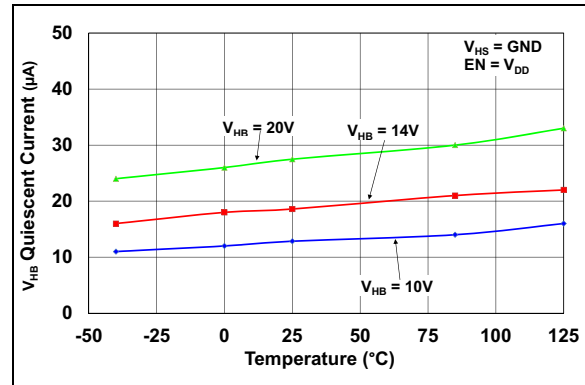
## 2.0 TYPICAL PERFORMANCE CURVES

**Note:** The graphs and tables provided following this note are a statistical summary based on a limited number of samples and are provided for informational purposes only. The performance characteristics listed herein are not tested or guaranteed. In some graphs or tables, the data presented may be outside the specified operating range (e.g., outside specified power supply range) and therefore outside the warranted range.

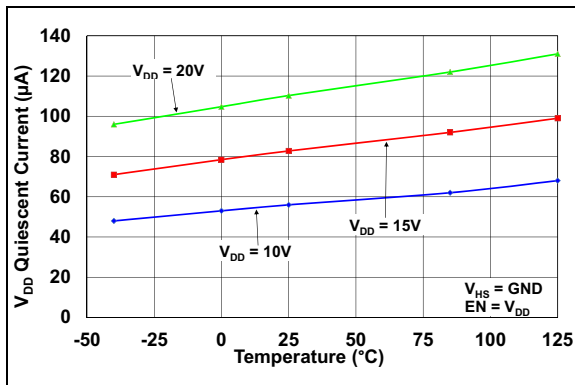
**Note:** Unless otherwise indicated,  $T_A = +25^\circ\text{C}$  with  $10\text{V} \leq V_{DD} \leq 20\text{V}$ .



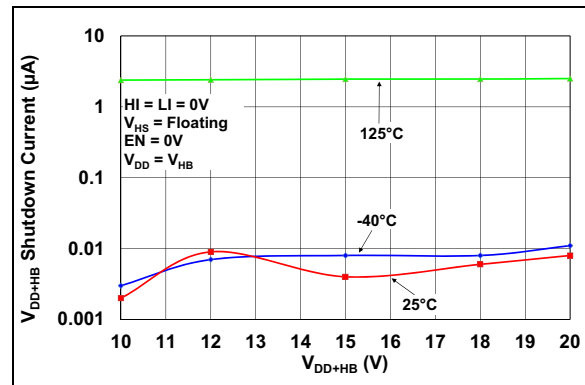
**FIGURE 2-1:**  $V_{DD}$  Quiescent Current vs.  $V_{DD}$  Voltage.



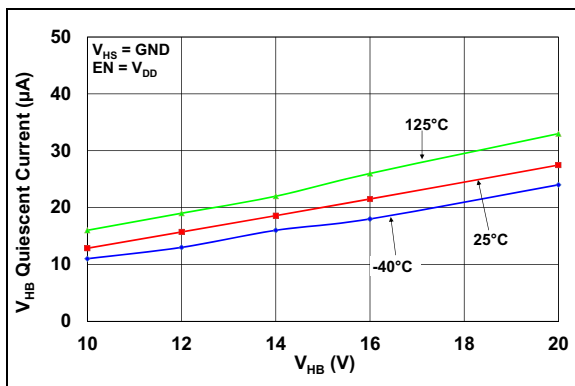
**FIGURE 2-4:**  $V_{HB}$  Quiescent Current vs. Temperature.



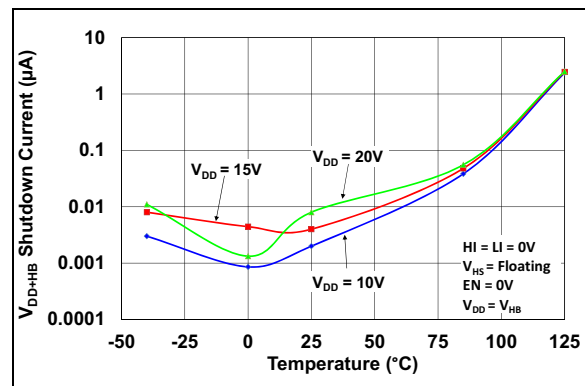
**FIGURE 2-2:**  $V_{DD}$  Quiescent Current vs. Temperature.



**FIGURE 2-5:**  $V_{DD+HB}$  Shutdown Current vs. Voltage.



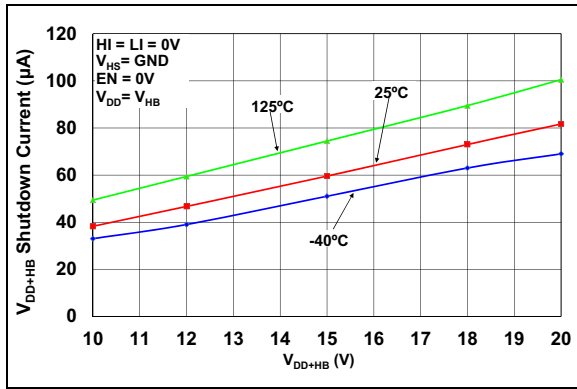
**FIGURE 2-3:**  $V_{HB}$  Quiescent Current vs.  $V_{HB}$  Voltage.



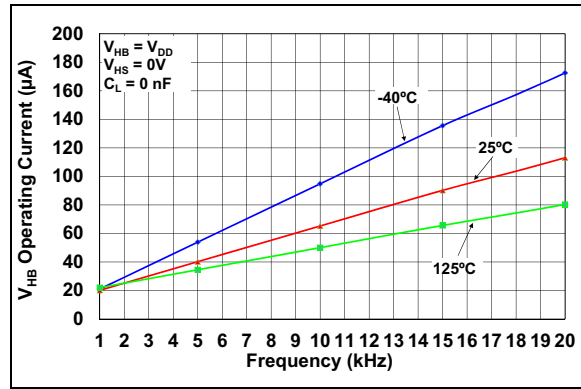
**FIGURE 2-6:**  $V_{DD+HB}$  Shutdown Current vs. Temperature.

# MIC4609

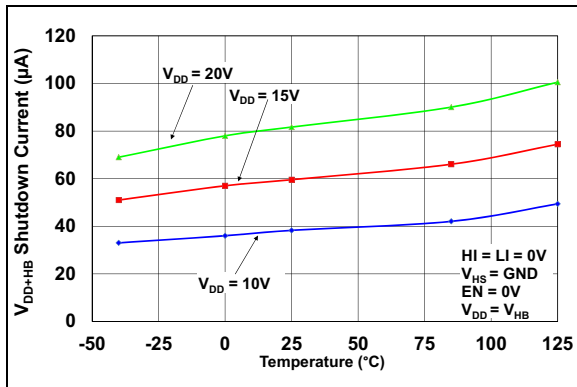
Note: Unless otherwise indicated,  $T_A = +25^\circ\text{C}$  with  $10\text{V} \leq V_{DD} \leq 20\text{V}$ .



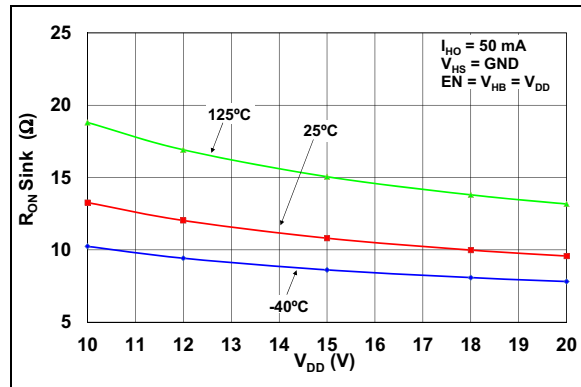
**FIGURE 2-7:**  $V_{DD+HB}$  Shutdown Current vs. Voltage.



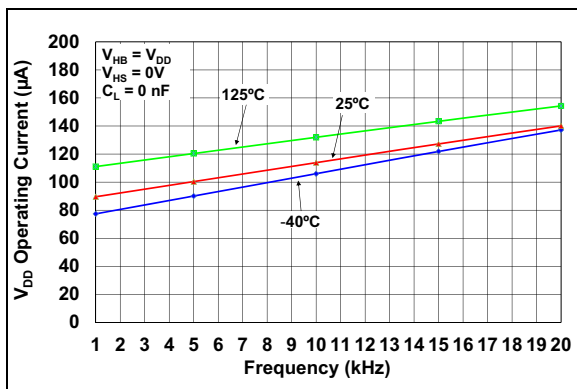
**FIGURE 2-10:**  $V_{HB}$  Operating Current vs. Frequency – One Phase.



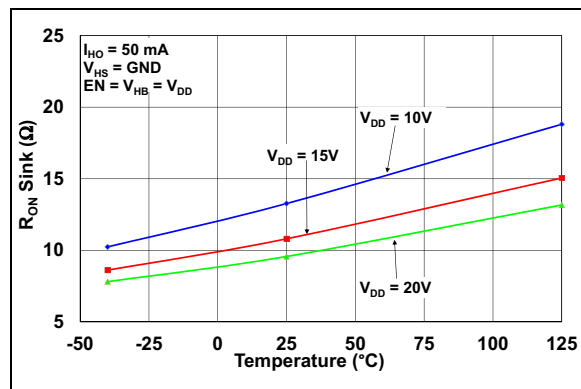
**FIGURE 2-8:**  $V_{DD+HB}$  Shutdown Current vs. Temperature.



**FIGURE 2-11:** HO Output Sink ON-Resistance vs.  $V_{DD}$ .

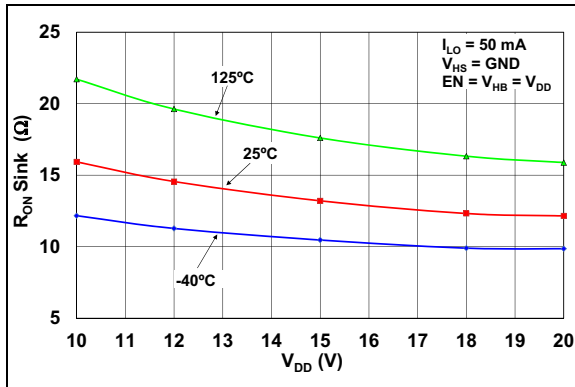


**FIGURE 2-9:**  $V_{DD}$  Operating Current vs. Frequency.

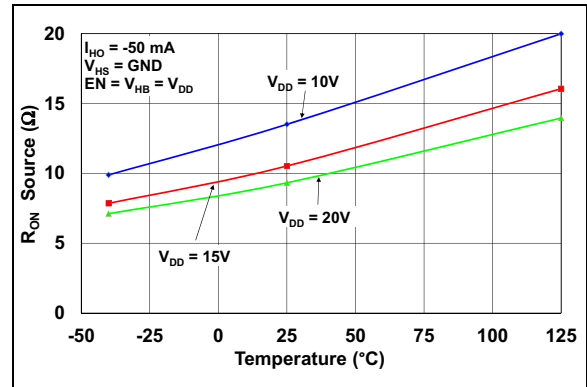


**FIGURE 2-12:** HO Output Sink ON-Resistance vs. Temperature.

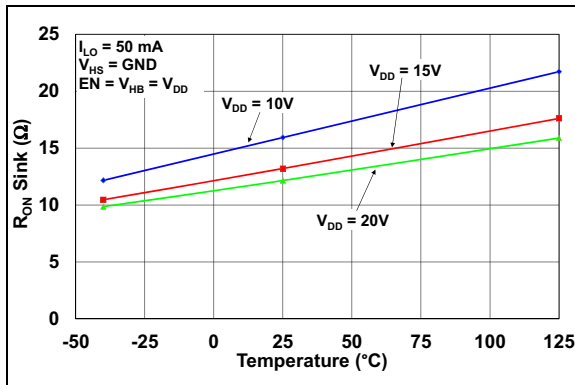
**Note:** Unless otherwise indicated,  $T_A = +25^\circ\text{C}$  with  $10\text{V} \leq V_{DD} \leq 20\text{V}$ .



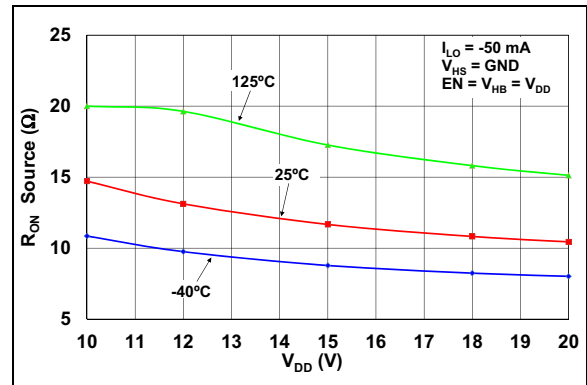
**FIGURE 2-13:** LO Output Sink ON-Resistance vs.  $V_{DD}$ .



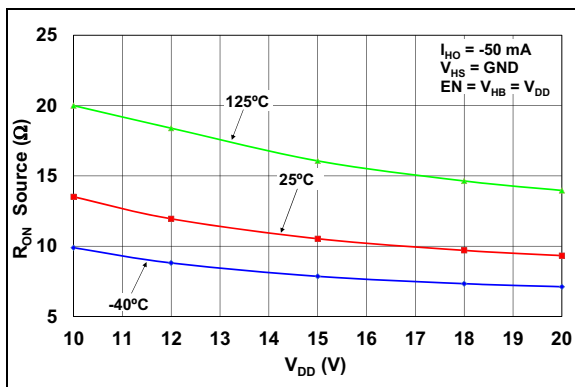
**FIGURE 2-16:** HO Output Source ON-Resistance vs. Temperature.



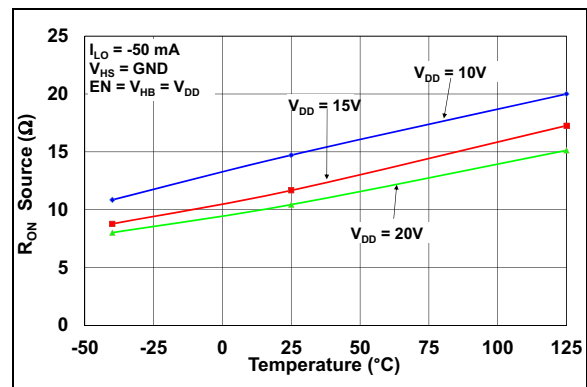
**FIGURE 2-14:** LO Output Sink ON-Resistance vs. Temperature.



**FIGURE 2-17:** LO Output Source ON-Resistance vs.  $V_{DD}$ .



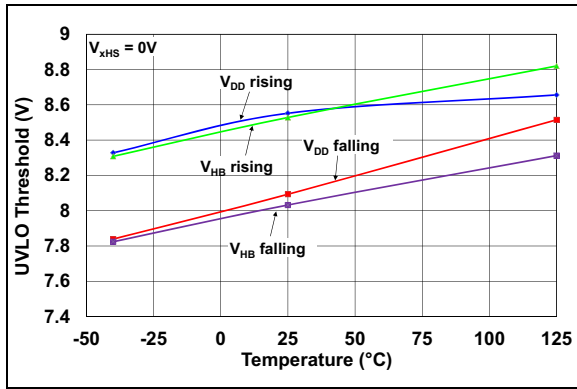
**FIGURE 2-15:** HO Output Source ON-Resistance vs.  $V_{DD}$ .



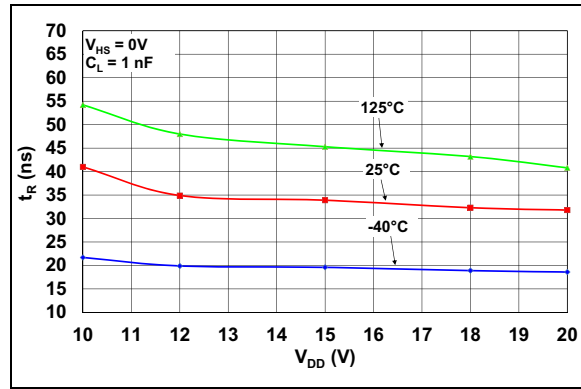
**FIGURE 2-18:** LO Output Source ON-Resistance vs. Temperature.

# MIC4609

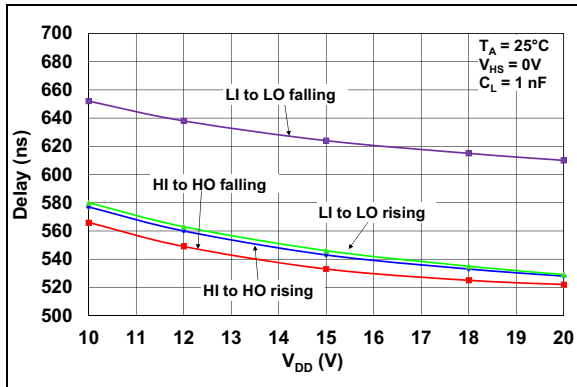
Note: Unless otherwise indicated,  $T_A = +25^\circ\text{C}$  with  $10\text{V} \leq V_{DD} \leq 20\text{V}$ .



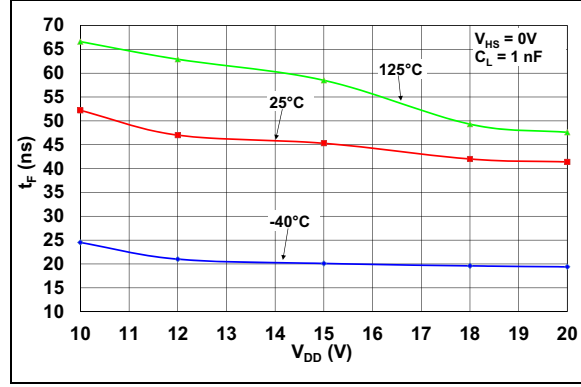
**FIGURE 2-19:**  $V_{DD}/V_{HB}$  ULVO vs. Temperature.



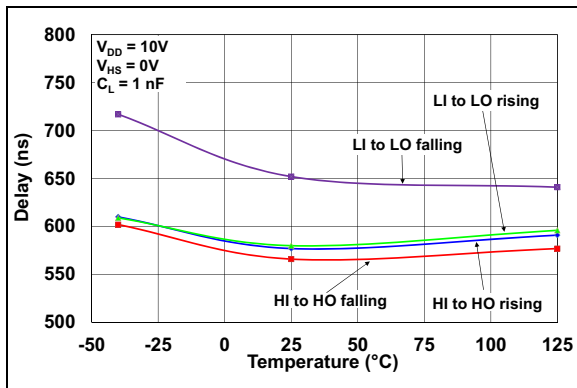
**FIGURE 2-22:** HO Rise Time vs.  $V_{DD}$  Voltage.



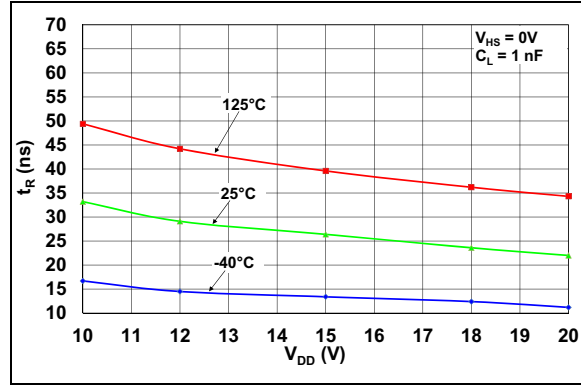
**FIGURE 2-20:** Propagation Delay vs.  $V_{DD}$  Voltage.



**FIGURE 2-23:** HO Fall Time vs.  $V_{DD}$  Voltage.

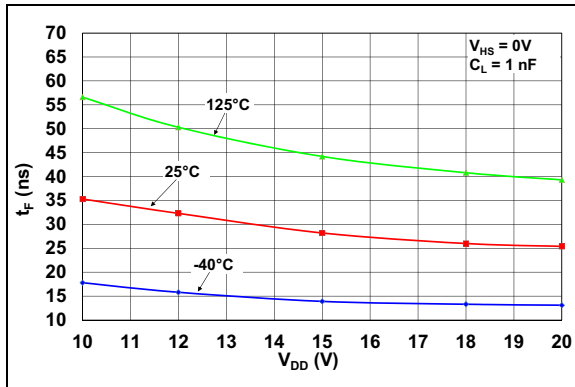


**FIGURE 2-21:** Propagation Delay vs. Temperature.

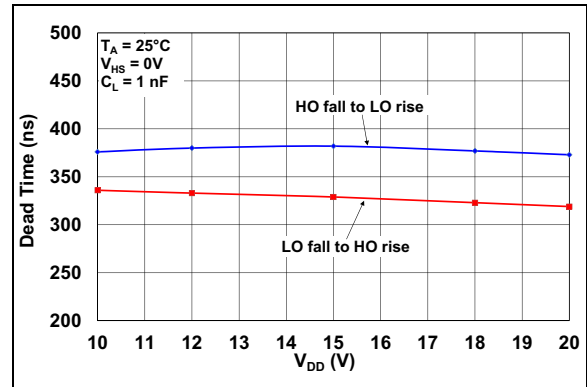


**FIGURE 2-24:** LO Rise Time vs.  $V_{DD}$  Voltage.

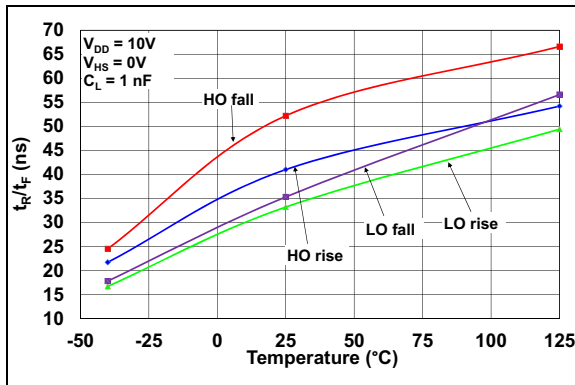
**Note:** Unless otherwise indicated,  $T_A = +25^\circ\text{C}$  with  $10\text{V} \leq V_{DD} \leq 20\text{V}$ .



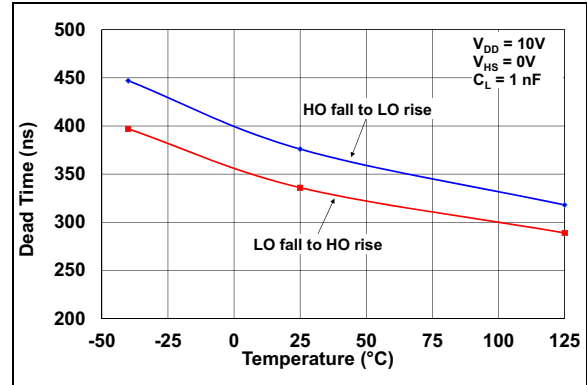
**FIGURE 2-25:** LO Fall Time vs.  $V_{DD}$  Voltage.



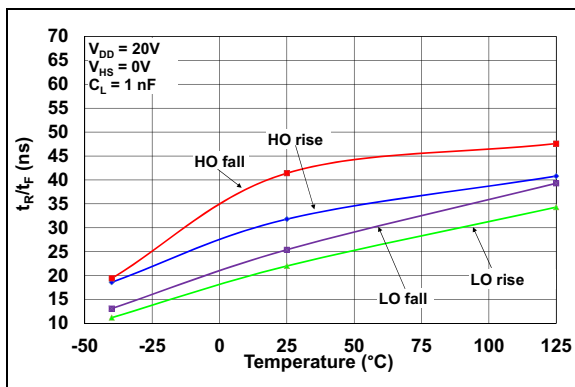
**FIGURE 2-28:** Dead Time vs.  $V_{DD}$  Voltage.



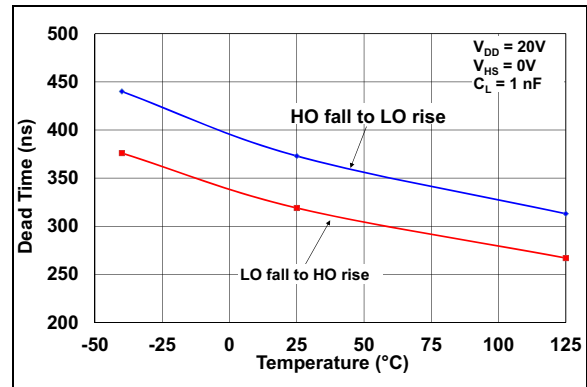
**FIGURE 2-26:** Rise/Fall Time vs. Temperature ( $V_{DD} = 10\text{V}$ ).



**FIGURE 2-29:** Dead Time vs. Temperature ( $V_{DD} = 10\text{V}$ ).



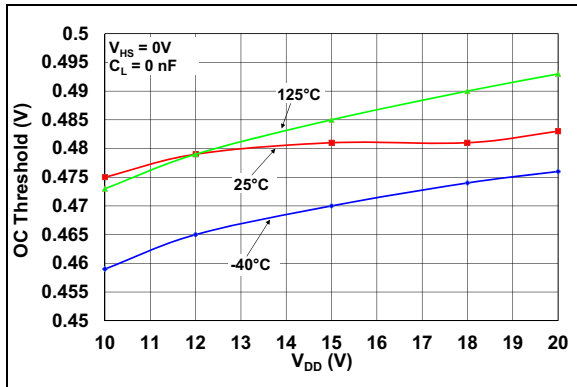
**FIGURE 2-27:** Rise/Fall Time vs. Temperature ( $V_{DD} = 20\text{V}$ ).



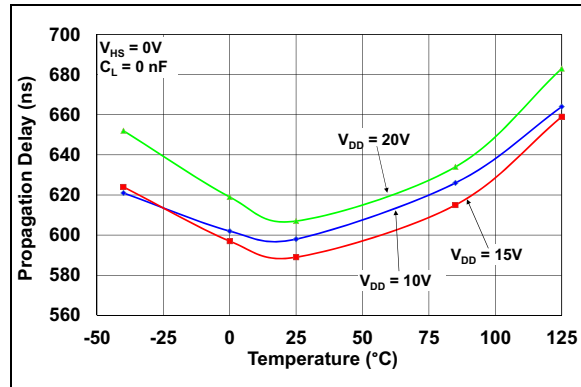
**FIGURE 2-30:** Dead Time vs. Temperature ( $V_{DD} = 20\text{V}$ ).

# MIC4609

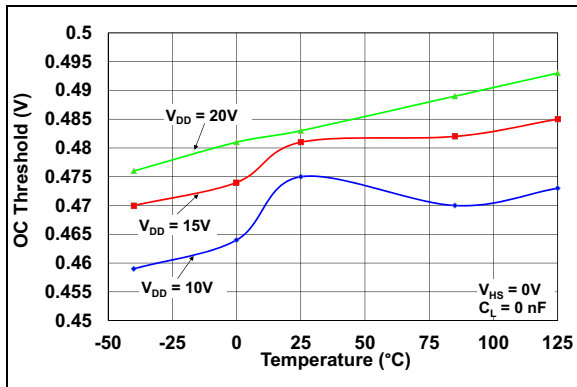
Note: Unless otherwise indicated,  $T_A = +25^\circ\text{C}$  with  $10\text{V} \leq V_{DD} \leq 20\text{V}$ .



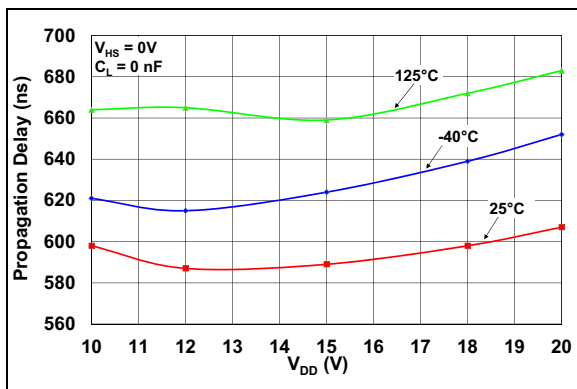
**FIGURE 2-31:** Overcurrent Threshold vs.  $V_{DD}$  Voltage.



**FIGURE 2-34:** Overcurrent Propagation Delay vs. Temperature.



**FIGURE 2-32:** Overcurrent Threshold vs. Temperature.



**FIGURE 2-33:** Overcurrent Propagation Delay vs.  $V_{DD}$  Voltage.

## 3.0 PIN DESCRIPTIONS

The descriptions of the pins are listed [Table 3-1](#).

**TABLE 3-1: PIN FUNCTION TABLE**

| Pin Number | Pin Name                  | I/O   | Description   |
|------------|---------------------------|-------|---|
| 1          | V <sub>DD</sub>           | Power | Input Supply for Gate Drivers<br>Decouple this pin to V <sub>SS</sub> with a > 2.2 μF capacitor.<br>Connect anode of bootstrap diodes to this pin.  |
| 2          | AHI                       | IN    | A-Phase High-Side Drive Input   |
| 3          | BHI                       | IN    | B-Phase High-Side Drive Input   |
| 4          | CHI                       | IN    | C-Phase High-Side Drive Input   |
| 5          | ALI                       | IN    | A-Phase Low-Side Drive Input  |
| 6          | BLI                       | IN    | B-Phase Low-Side Drive Input  |
| 7          | CLI                       | IN    | C-Phase Low-Side Drive Input  |
| 8          | $\overline{\text{FAULT}}$ | OUT   | Fault Output<br>Open-drain asserts low to indicate Overcurrent or V <sub>DD</sub> Undervoltage condition.   |
| 9          | ISNS                      | IN    | Current Sense Input for Overcurrent Shutdown  |
| 10         | EN                        | IN    | Enable Input<br>Logic high on the Enable pin results in normal operation.<br>Logic low forces the device to enter Shutdown mode.  |
| 11         | RCIN                      | OUT   | Overcurrent Fault Clear Delay Pin<br>Connect to an external capacitor to set the fault clear delay.   |
| 12         | V <sub>SS</sub>           | GND   | Logic Ground Pin  |
| 13         | COM                       | —     | Low-Side Driver Return Pin  |
| 14         | CLO                       | OUT   | C-Phase Low-Side Drive Output<br>Connect to the gate of the external low-side power MOSFET or IGBT.   |
| 15         | BLO                       | OUT   | B-Phase Low-Side Drive Output<br>Connect to the gate of the external low-side power MOSFET or IGBT.   |
| 16         | ALO                       | OUT   | A-Phase Low-Side Drive Output<br>Connect to the gate of the external low-side power MOSFET or IGBT.   |
| 17, 21, 25 | NC                        | —     | No Connect  |
| 18         | CHS                       | —     | C-Phase High-Side Drive Return Connection<br>Connect to the emitter or source of the external high-side power device.<br>Connect the bootstrap capacitor between this pin and the CHB pin.            |
| 19         | CHO                       | OUT   | C-Phase High-Side Drive Output<br>Connect to the gate of the external high-side power MOSFET or IGBT.   |
| 20         | CHB                       | Power | C-Phase High-Side Bootstrap Supply<br>External bootstrap capacitor is required.<br>Connect the bootstrap capacitor between this pin and CHS.<br>Connect to the anode of the external bootstrap diode. |
| 22         | BHS                       | —     | B-Phase High-Side Drive Return Connection<br>Connect to the emitter or source of the external high-side power device.<br>Connect the bootstrap capacitor between this pin and the BHB pin.            |
| 23         | BHO                       | OUT   | B-Phase High-Side Drive Output<br>Connect to the gate of the external high-side power MOSFET or IGBT.   |

# MIC4609

---

**TABLE 3-1: PIN FUNCTION TABLE (CONTINUED)**

| Pin Number | Pin Name | I/O   | Description   |
|------------|----------|-------|---|
| 24         | BHB      | Power | B-Phase High-Side Bootstrap Supply<br>External bootstrap capacitor is required.<br>Connect the bootstrap capacitor between this pin and BHS.<br>Connect to the anode of the external bootstrap diode. |
| 26         | AHS      | —     | A-Phase High-Side Drive Return Connection<br>Connect to the emitter or source of the external high-side power device.<br>Connect the bootstrap capacitor between this pin and the AHB pin.            |
| 27         | AHO      | OUT   | A-Phase High-Side Drive Output<br>Connect to the gate of the external high-side power MOSFET or IGBT.   |
| 28         | AHB      | Power | A-Phase High-Side Bootstrap Supply<br>External bootstrap capacitor is required.<br>Connect the bootstrap capacitor between this pin and AHS.<br>Connect to the anode of the external bootstrap diode. |



## 4.0 FUNCTIONAL DESCRIPTION

The MIC4609 is a noninverting, 600V three-phase IGBT/MOSFET driver designed to independently drive six IGBTs or MOSFETs in a three-phase bridge. The MIC4609 offers a wide 10V-to-20V  $V_{DD}$  operating supply range with six independent inputs (TTL- or 3.3V CMOS-compatible).

The driver is comprised of six input buffers with hysteresis, four independent UVLO circuits (three high-side monitoring the HB voltage and one low-side monitoring the  $V_{DD}$  voltage), and six output drivers. The high-side output drivers utilize a high-speed level-shifting circuit that is referenced to the HS pin. An overcurrent protection circuit turns off all outputs during an overcurrent fault.

### 4.1 UVLO Protection

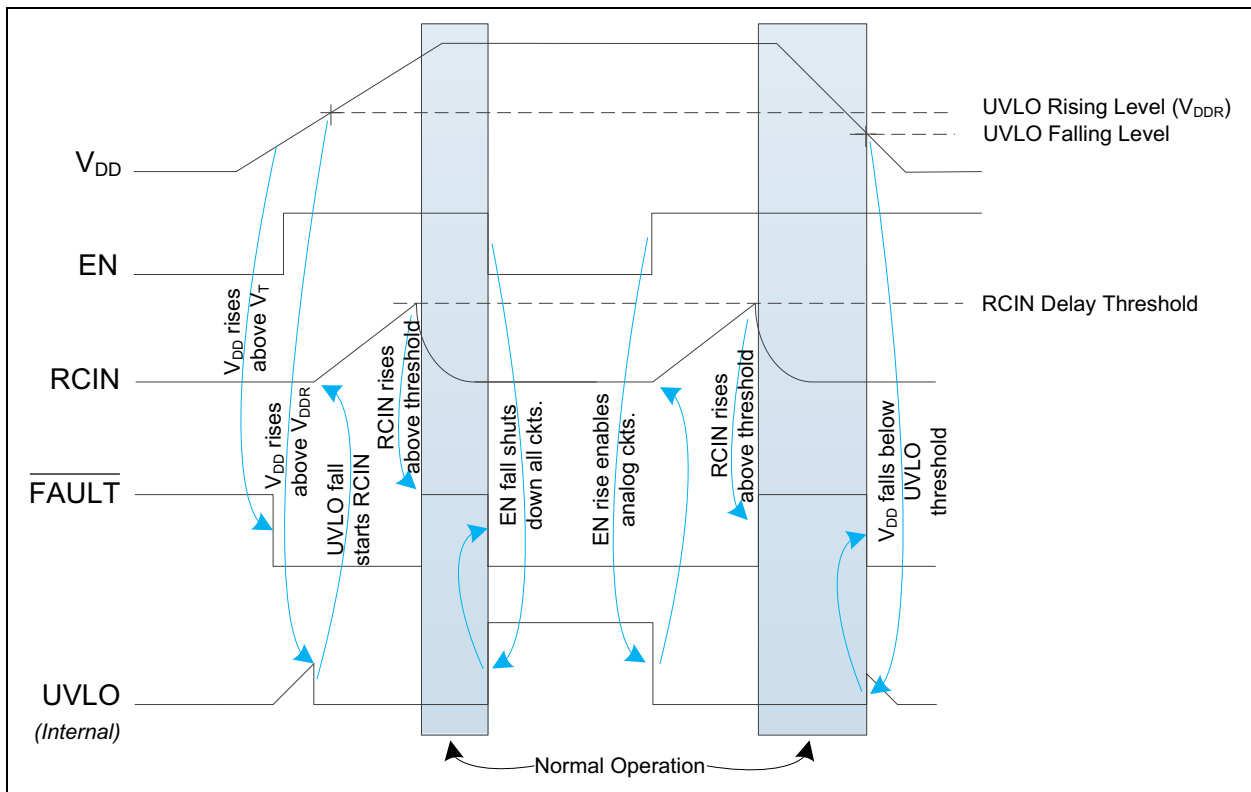
The UVLO circuits force the driver's outputs low until the supply voltage exceeds the UVLO threshold. Hysteresis in the UVLO circuits prevents system noise and finite circuit impedance from causing chatter during turn-on.

The UVLO circuits are illustrated in the functional block diagrams. The low-side UVLO circuit, [Functional Block Diagram MIC4609 – Phase x Drive Circuit](#), monitors the voltage between the  $V_{DD}$  and  $V_{SS}$  pins. The circuit keeps all the drivers off when  $V_{DD}$  is less than the UVLO threshold voltage.

The three high-side UVLO circuits, shown in [Typical Application Circuit MIC4609 – 300V, 3-Phase Motor Driver](#), monitor the voltage between the xHB and xHS pins. The circuit keeps its respective high-side output off when  $V_{HB} - V_{HS}$  is less than the UVLO threshold voltage.

### 4.2 Startup and UVLO




The start-up sequence is illustrated in [Figure 4-1](#). As  $V_{DD}$  rises above an unspecified threshold,  $V_T$ , the internal circuitry becomes active, the  $\overline{\text{FAULT}}$  pin asserts low and the UVLO circuitry begins to monitor  $V_{DD}$ . When the rising  $V_{DD}$  reaches the UVLO threshold, a current source begins charging the RCIN pin's external capacitor until it reaches the RCIN delay threshold. The output drivers are enabled once the RCIN threshold is reached and the EN pin is asserted high.



**FIGURE 4-1:** Startup and Fault Timing Diagram.

# MIC4609

**TABLE 4-1: OPERATIONAL TRUTH TABLE**

| Condition            | xHI | xLI    | EN  | ULVO (1, 2)   |   | Outputs (3, 4) |        |
|----------------------|-----|--------|---|---|---|----------------|--------|
|                      |     |        |   | HB ULVO   | V <sub>DD</sub> ULVO  | xHO            | xLO    |
| Disabled             | X   | X      | L   | X   | X   | L              | L      |
| V <sub>DD</sub> ULVO | X   | X      | X   | X   | L   | L              | L      |
| V <sub>HB</sub> ULVO | X   | L or H | H   | L   | H   | L              | L or H |
| Switching            | H   | H      |  | H   | H   | L              | L      |
|                      | H   | H      | H   |  |  | L              | L      |
|                      | L   | H      | H   | H   | H   | L              | H      |
|                      | H   | L      | H   | H   | H   | H              | L      |
|                      | L   | L      | H   | H   | H   | H              | L      |

- Note 1:** UVLO = H when V<sub>DD</sub> > UVLO threshold  
**Note 2:** UVLO = L when V<sub>DD</sub> < UVLO threshold  
**Note 3:** xHO and xLO remain low if both xHI and xLI are low when the V<sub>DD</sub> rises above the UVLO threshold or when the EN pin is asserted high. Normal switching operation begins when one of the inputs changes state from L to H.  
**Note 4:** Anti-shoot-through circuit prevents a high on both outputs simultaneously.

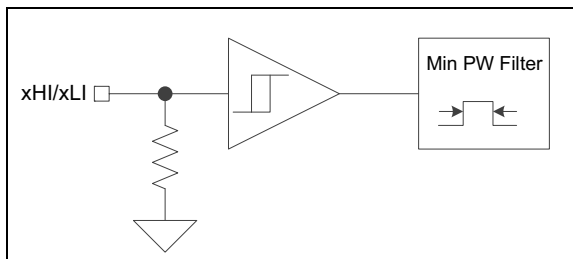
## 4.3 Enable Inputs

There is one external Enable pin that controls all three phases. A logic high on the enable pin (EN) allows for startup of all phases and normal operation. Conversely, when a logic low is applied on the Enable pin, all phases turn off and the device enters a low current Shutdown mode. All outputs (xHO and xLO) are pulled low when EN is low. The EN pin is internally pulled down. Leaving the pin open disables the part.

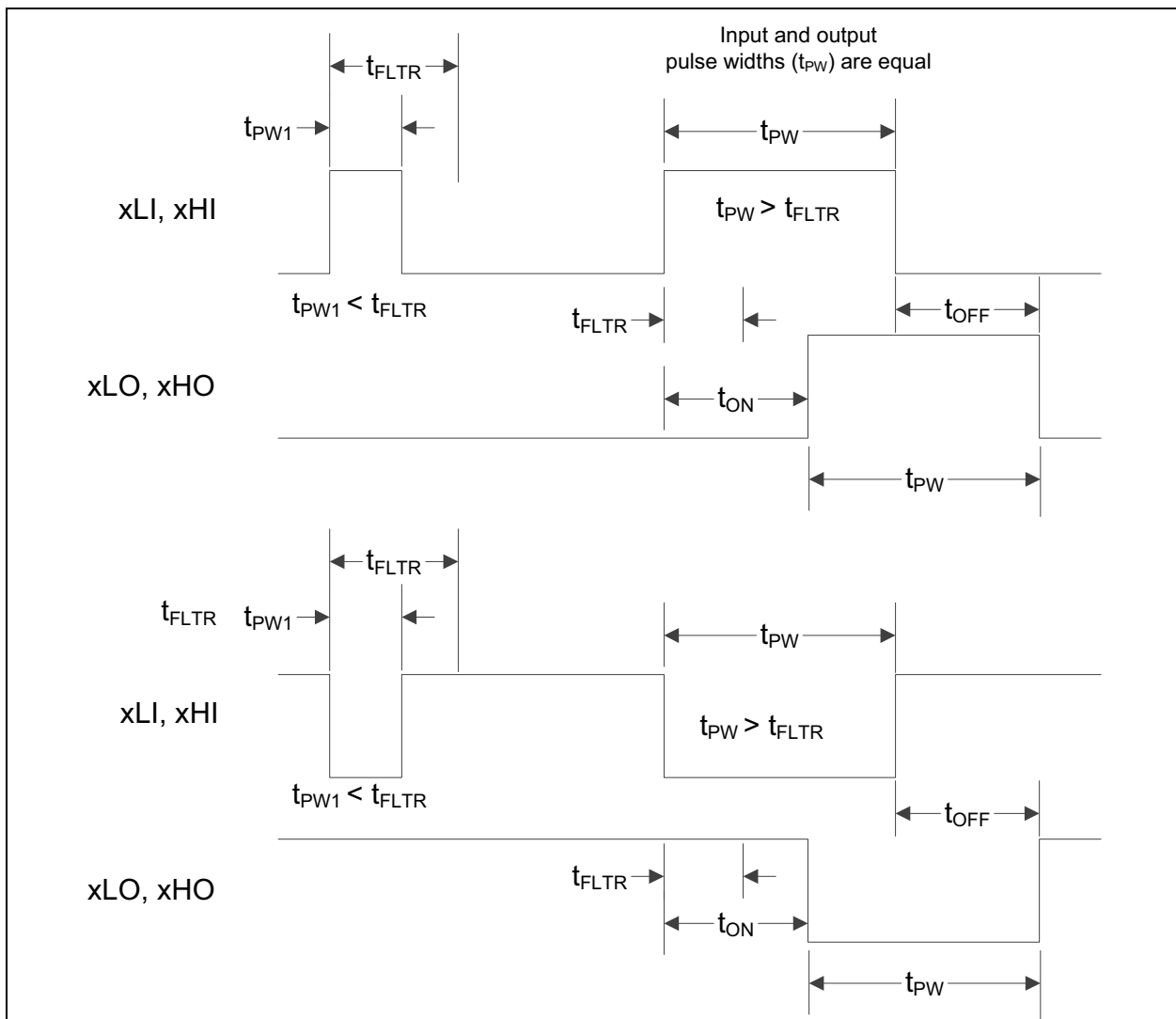
## 4.4 Input Stage

The xHI and xLI pins are referenced to the COM pin and have a CMOS/TTL compatible input range. The input threshold voltage is independent of the  $V_{DD}$  supply. The input pin voltage must not exceed the  $V_{DD}$  pin voltage. The voltage state of the input signal(s) does not change the quiescent current draw of the driver. The input stage block diagram is shown in Figure 4-2.

An internal pull-down resistor is connected to the xHI and xLI pins. This pulls the driver output pins low if the inputs are disconnected or left floating. A small amount of hysteresis is programmed into the input to prevent false triggering of the output. In addition, each input has a minimum pulse-width filter for additional noise immunity. The input pulse width must exceed the  $t_{FLTR}$  time before the outputs will change state. Refer to the Electrical Characteristics table and Figure 4-3 for additional information.



**FIGURE 4-2:** Input Stage Block Diagram.



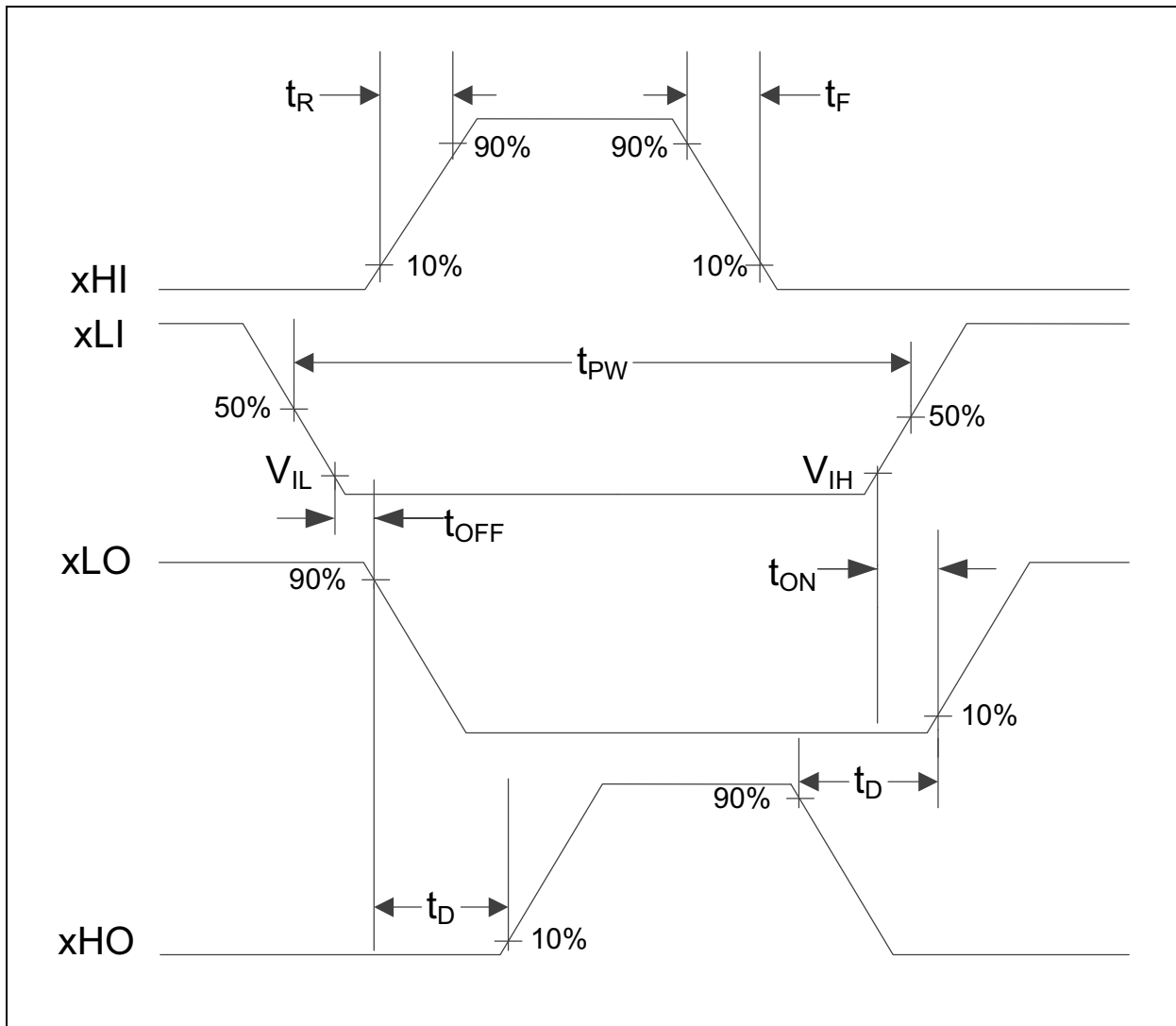
**FIGURE 4-3:** Minimum Pulse-Width Diagram.

# MIC4609

## 4.5 Dead Time and Anti-Shoot-Through Protection

Shoot-through occurs when both the high and low-side IGBTs/MOSFETs of a particular phase are ON at the same time. The inputs of each phase use anti-shoot-through circuitry to prevent this condition from occurring. If both the HI and LI inputs of a phase go high, both outputs (HO and LO) of that phase go low.

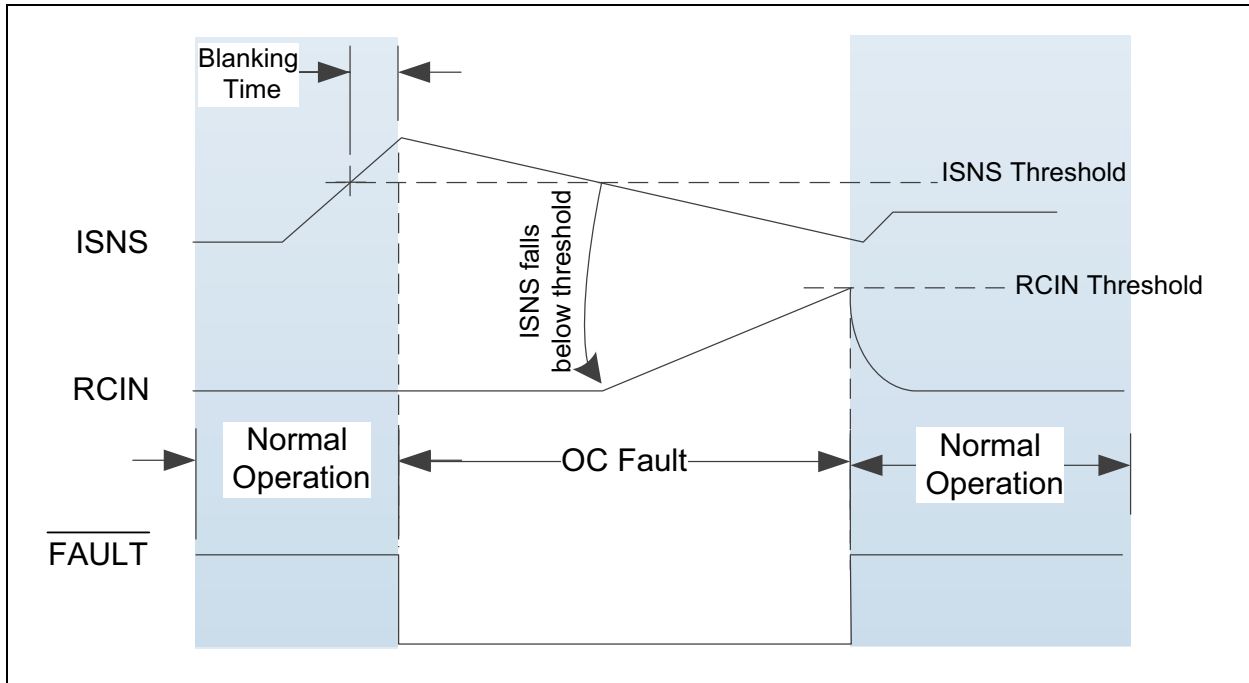
In addition to anti-shoot-through circuitry, a fixed "dead-time" delay is added to the input-to-output propagation delay. This allows the IGBTs/MOSFETs in a particular phase to fully turn off before the other turns on.



**FIGURE 4-4:** Dead Time, Propagation Delay, and Rise/Fall-Time Diagram.







**FIGURE 4-8:** Overcurrent Fault Sequence.

#### 4.8.1 ISNS

The ISNS pin may be used to monitor motor winding currents. The measurement is referenced to the  $V_{SS}$  pin and can sense the voltage across a low-side current sense resistor or it may be connected to a current sense transformer. The current sense resistor is typically connected between the source pins (MOSFET) or emitter pins (IGBT) of all three low-side switches and power ground.

If the peak voltage on the ISNS pin exceeds the  $V_{ISNS}$  threshold, it will cause all six outputs to latch off. A blanking circuit on the ISNS comparator output prevents noise from falsely tripping the overcurrent circuit. The ISNS pin is internally pulled down to  $V_{SS}$  but may be externally connected to  $V_{SS}$  ground for improved noise immunity if the overcurrent feature is not used.

#### 4.8.2 RCIN

A capacitor connected to the RCIN pin determines the amount of time the gate drive outputs are latched off before they can be restarted.

During normal operation, the RCIN pin is internally pulled low. Once an overcurrent condition is detected, the RCIN pin capacitor is charged up by an internal current source until the voltage reaches the  $V_{RCIN+}$  threshold and the latch is reset. The outputs are then enabled.

The delay time can be approximated by applying Equation 4-1.

#### EQUATION 4-1:

$$t_{DLY} = \frac{C_{RCIN} \times V_{RCIN+}}{I_{RCIN}}$$

Where:

$C_{RCIN}$  = External capacitance on the RCIN pin

$I_{RCIN}$  = RCIN pin current source (typically 5  $\mu$ A)

$V_{RCIN+}$  = Internal comparator threshold

#### 4.8.3 $\overline{\text{FAULT}}$

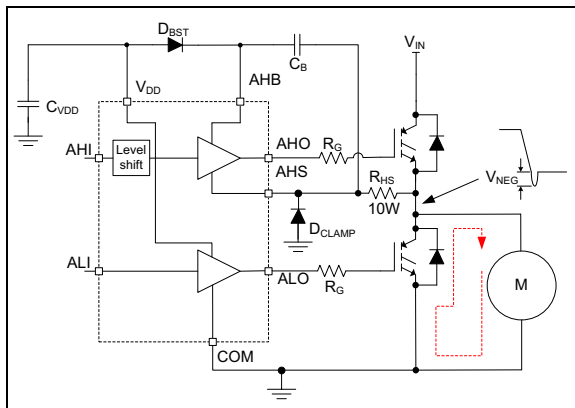
This open-drain output is asserted low for an overcurrent condition or when the  $V_{DD}$  voltage is below the UVLO threshold. It will de-assert to a high-impedance state once the  $V_{DD}$  rises above the UVLO threshold or when the RCIN pin voltage has reached the  $V_{RCIN+}$  threshold. During normal operation, the internal pull-down MOSFET of the pin is high impedance. A pull-up resistor must be connected to this pin.





amount of negative voltage on the switch node, a 1A fast recovery diode and a minimum 10Ω resistor are recommended. A higher current diode and/or larger values of resistance can be used if necessary.

Adding a series resistor in the switch node limits the peak high-side driver current, which affects the switching speed of the high-side driver. The resistor, in series with the HO pin, may be reduced to help compensate for the extra HS pin resistance.



**FIGURE 5-2:** Negative HS Pin Voltage.

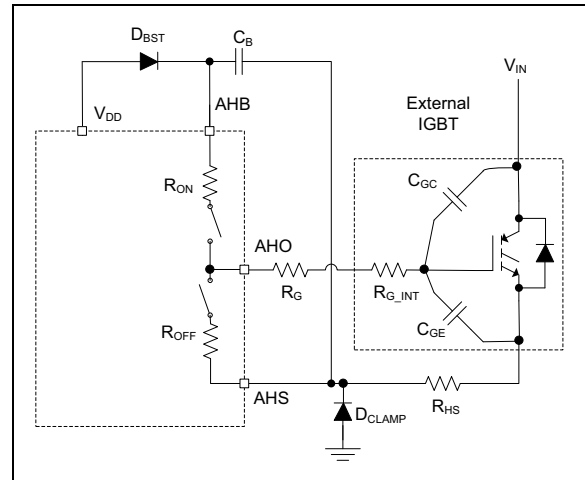
## 5.3 Power Dissipation Considerations

Power dissipation in the driver can be separated into two areas:

- Gate driver dissipation
- Quiescent current dissipation used to supply the internal logic and control functions

### 5.3.1 GATE DRIVER POWER DISSIPATION

Power dissipation in the output driver stage is mainly caused by charging and discharging the gate-to-emitter and gate-to-collector capacitance of the external IGBT. Figure 5-3 shows a simplified equivalent circuit of the MIC4609 driving an external high-side IGBT.

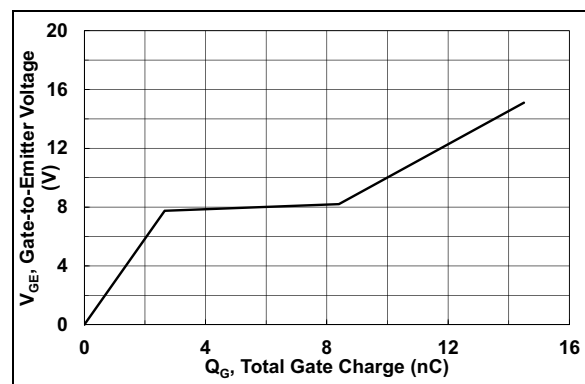


**FIGURE 5-3:** MIC4609 High-Side Driving an External IGBT.

### 5.3.2 DISSIPATION DURING THE EXTERNAL IGBT/MOSFET TURN-ON

Energy from capacitor  $C_B$  is used to charge up the input capacitance of the IGBT ( $C_{GE}$  and  $C_{GC}$ ). The energy delivered to the gate is dissipated in the three resistive components,  $R_{ON}$ ,  $R_G$  and  $R_{G\_INT}$ .  $R_G$  is the series resistor between the driver output and the IGBT.  $R_{G\_INT}$  is the gate resistance of the IGBT.  $R_{G\_INT}$  is usually listed in the IGBT or MOSFET specifications. The ESR of capacitor  $C_B$  and the resistance of the connecting etch can be ignored because they are much less than  $R_{ON}$  and  $R_{G\_INT}$ .

The effective capacitances of  $C_{GE}$  and  $C_{GC}$  are difficult to calculate because they vary nonlinearly with  $I_C$ ,  $V_{GE}$ , and  $V_{CE}$ . Most power IGBT and MOSFET specifications include a graph of total gate charge versus  $V_{GE}$ . Figure 5-4 shows a typical gate charge curve for an arbitrary IGBT. The chart shows that for a gate voltage of 12V, the IGBT requires 12 nC of charge.



**FIGURE 5-4:** Typical Gate Charge vs.  $V_{GE}$ .

# MIC4609

The power dissipated by the resistive components of the gate drive circuit during turn-on is calculated as shown in [Equation 5-3](#).

## EQUATION 5-3:

$$P_{DRIVER} = Q_G \times V_{GE} \times f_S \times D$$

Where:

$P_{DRIVER}$  <sup>(1)</sup> = Average drive circuit power due to switching

$Q_G$  = Total gate charge at  $V_{GE}$

$V_{GE}$  = Gate-to-emitter voltage on the IGBT

$f_S$  = Switching frequency of the gate drive circuit

$D$  <sup>(2)</sup> = Operating duty cycle of the driver output

**Note 1:**  $P_{DRIVER}$  is the power dissipated by the individual driver for one of the six gate drive outputs.

**2:** Operating duty cycle is the percentage of time that particular driver output is switching during one rotation of the motor.

The power dissipated by each of the internal gate drivers (high-side or low-side) is equal to the ratio of  $R_{ON}$  and  $R_{OFF}$  to the external resistive losses in  $R_G$  and  $R_{G\_INT}$ .

Letting  $R_{ON} = R_{OFF}$ , the power dissipated in the individual driver output in the IC is calculated as shown in [Equation 5-4](#):

## EQUATION 5-4:

$$P_{DISS} = P_{DRIVER} \times \frac{R_{ON}}{R_{ON} + R_G + R_{G\_INT}}$$

The total power dissipated in the MIC4609, due to switching, is equal to the sum of all six driver dissipations.

### 5.3.3 SUPPLY CURRENT POWER DISSIPATION

Power is dissipated in the MIC4609 even if nothing is being driven. The supply current is drawn by the bias for the internal circuitry, the level shifting circuitry, and shoot-through current in the output drivers. The supply current is proportional to the operating frequency and the  $V_{DD}$  and  $V_{HB}$  voltages. [Figures 2-9](#) and [2-10](#) show how supply current varies with switching frequency and supply voltage.

The power dissipated by the MIC4609 due to supply current is calculated by applying [Equation 5-5](#).

## EQUATION 5-5:

$$P_{DISS\_SUPPLY} = V_{DD} \times I_{DD} \times V_{HB} \times I_{HB}$$

### 5.3.4 TOTAL POWER DISSIPATION AND THERMAL CONSIDERATIONS

Total power dissipation in the MIC4609 is equal to the power dissipation caused by driving the external IGBTs and the supply current. [Equation 5-6](#) shows this relation.

## EQUATION 5-6:

$$P_{DISS\_TOTAL} = P_{DISS\_SUPPLY} + \sum P_{DISS\_DRIVERS}$$

The die temperature can be calculated after the total power dissipation is determined as shown in [Equation 5-7](#).

## EQUATION 5-7:

$$T_J = T_A + P_{DISS\_TOTAL} \times \theta_{JA}$$

Where:

$T_A$  = Maximum ambient temperature (°C)

$T_J$  = Junction temperature (°C)

$P_{DISS\_TOTAL}$  = MIC4609 power dissipation (W)

$\theta_{JA}$  = Thermal resistance from junction-to-ambient air (°C/W)

## 5.3.5 OTHER TIMING CONSIDERATIONS

Make sure the input signal pulse width is greater than the minimum specified pulse width. An input signal that is less than the minimum pulse width may result in no output pulse or an output pulse whose width is significantly less than the input.

The maximum duty cycle (ratio of high-side on-time to switching period) is controlled by the minimum pulse width of the low side and by the time required for the  $C_B$  capacitors to charge during the off-time. Adequate time must be allowed for the  $C_B$  capacitor to charge up before the high-side driver is turned on.

## 5.4 Decoupling Capacitor Selection

Decoupling capacitors are required on the  $V_{DD}$  pin to supply the charge necessary to drive the external IGBTs or MOSFETs and also to minimize the voltage ripple on these pins. The  $V_{DD}$  pin decoupling capacitor supplies the transient current for all six drivers (three high-side and three low-side). The minimum recommended  $V_{DD}$  capacitance should be greater than the sum of all three  $C_B$  capacitors with a minimum 1  $\mu\text{F}$  ceramic capacitor regardless of  $C_B$  value.

Ceramic capacitors are recommended because of their low impedance and small size. Z5U-type ceramic capacitor dielectrics should not be used due to the large change in capacitance over temperature and voltage. Larger IGBTs/MOSFETs and low-switching frequencies may require larger capacitance values for proper operation. The voltage rating of the capacitors depends on the supply voltage, ambient temperature and the voltage derating used for reliability. 25V-rated X5R or X7R ceramic capacitors are recommended for most applications. The minimum capacitance value should be increased if low voltage capacitors are used because even good quality dielectric capacitors, such as X5R, will lose 40% to 70% of their capacitance value at the rated voltage.

Placement of the decoupling capacitors is critical. The bypass capacitor for  $V_{DD}$  should be placed as close as possible between the  $V_{DD}$  pin and the ground plane. The bypass capacitor ( $C_B$ ) for the HB supply pin must be located as close as possible between the HB and HS pins. The etch connections must be short, wide, and direct. The use of a ground plane to minimize connection impedance is recommended.

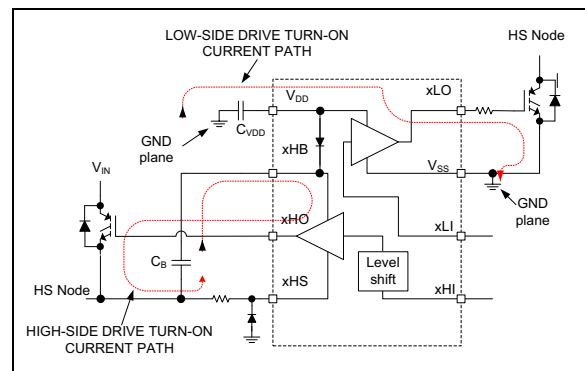
## 5.5 Grounding, Component Placement, and Circuit Layout

Nanosecond switching speeds and high-peak currents in and around the MIC4609 driver requires proper placement and trace routing of all components. Improper placement may cause degraded noise immunity, false switching, excessive ringing, or circuit latch-up.

Figure 5-5 shows the critical current paths when the driver outputs go high and turn on the external IGBTs. It also helps demonstrate the need for a low impedance ground plane. Charge needed to turn on the IGBT gates comes from the decoupling capacitors  $C_{VDD}$  and  $C_B$ . Current in the low-side gate driver flows from  $C_{VDD}$  through the internal driver, into the IGBT gate, and out the emitter. The return connection back to the decoupling capacitor is made through the ground plane. Any inductance or resistance in the ground return path causes a voltage spike or ringing to appear on the emitter of the IGBT. This voltage works against the gate drive voltage and can either slow down or turn off the IGBT during the period when it should be turned on.

Current in the high-side driver is sourced from capacitor  $C_B$  and flows into the HB pin and out the HO pin, into the gate of the high-side IGBT. The return path for the current is from the emitter of the IGBT and back to capacitor  $C_B$ . The high-side circuit return path usually does not have a low-impedance ground plane so the etch connections in this critical path should be short and wide to minimize parasitic inductance. As with the low-side circuit, impedance between the IGBT emitter and the decoupling capacitor causes negative voltage feedback that fights the turn-on of the IGBT.

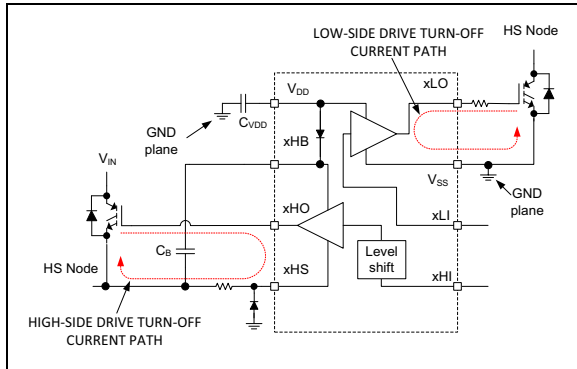
It is important to note that capacitor  $C_B$  must be placed close to the HB and HS pins. This capacitor not only provides the current for turn-on but it must also keep HB pin noise and ripple low for proper operation of the high-side drive circuitry.



**FIGURE 5-5:** Turn-On Current Paths.

# MIC4609

Figure 5-5 shows the critical current paths when the driver outputs go low and turn off the external IGBTs. Short, low-impedance connections are important during turn-off for the same reasons given in the turn-on explanation. Current flowing through the internal diode replenishes charge in the bootstrap capacitor,  $C_B$ .

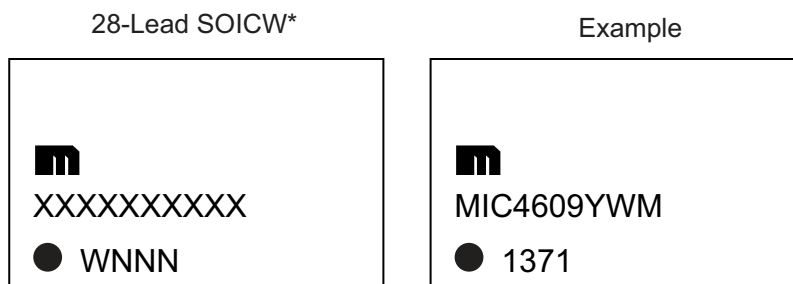


**FIGURE 5-6:** Turn-Off Current Paths.

It is highly recommended to use a ground plane to minimize parasitic inductance and impedance of the return paths. The MIC4609 is capable of greater than 1A peak currents and any impedance between the MIC4609, the decoupling capacitors, and the external IGBTs/MOSFETs will degrade the performance of the driver.

## 6.0 PACKAGING INFORMATION

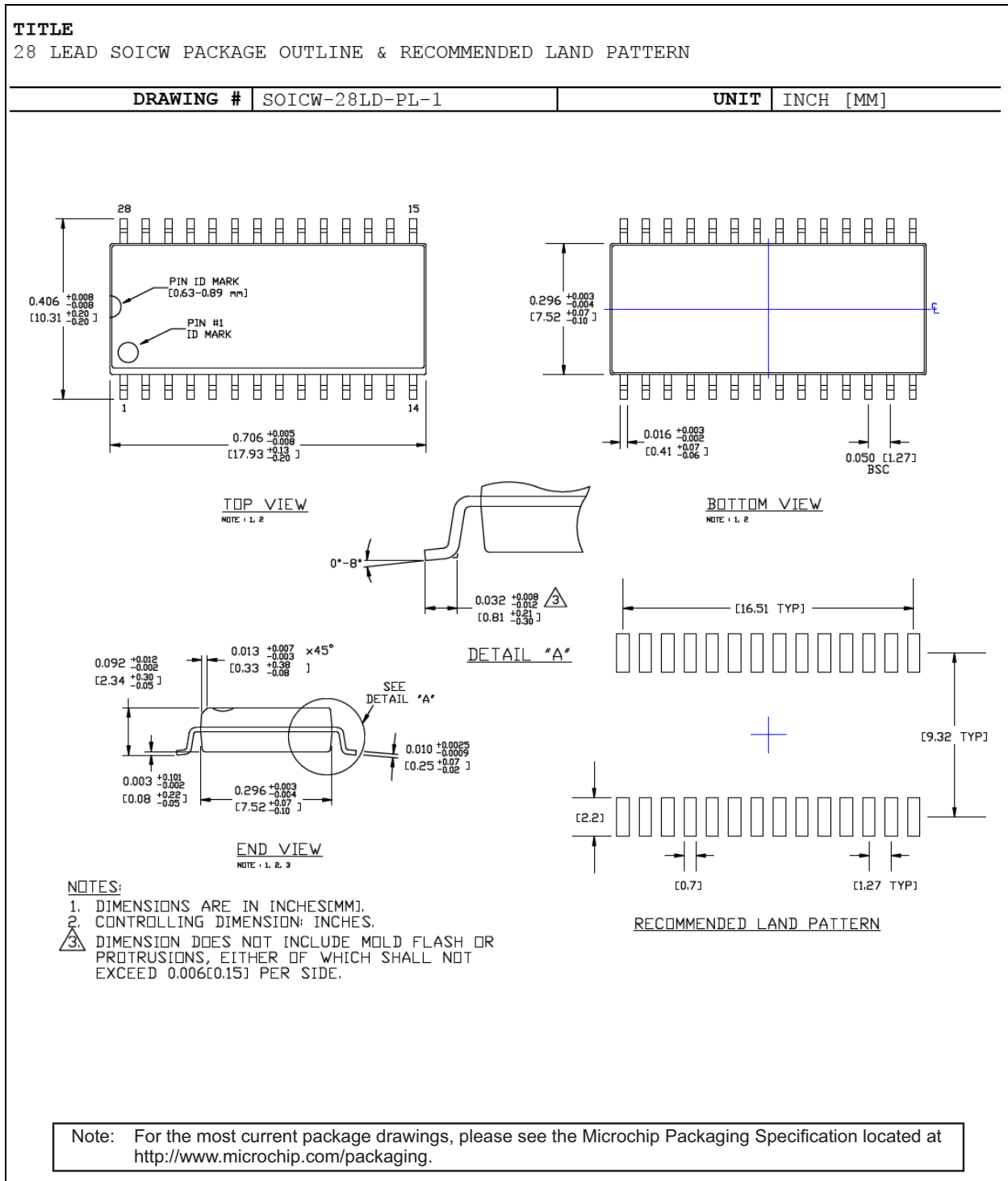
### 6.1 Package Marking Information



|  |
|--|
| <p><b>Legend:</b></p> <p>XX...X Product code or customer-specific information</p> <p>Y Year code (last digit of calendar year)</p> <p>YY Year code (last 2 digits of calendar year)</p> <p>WW Week code (week of January 1 is week '01')</p> <p>NNN Alphanumeric traceability code</p> <p>(e3) Pb-free JEDEC<sup>®</sup> designator for Matte Tin (Sn)</p> <p>* This package is Pb-free. The Pb-free JEDEC designator ((e3)) can be found on the outer packaging for this package.</p> <p>•, ▲, ▼ Pin one index is identified by a dot, delta up, or delta down (triangle mark).</p> <p><b>Note:</b> In the event the full Microchip part number cannot be marked on one line, it will be carried over to the next line, thus limiting the number of available characters for customer-specific information. Package may or may not include the corporate logo.</p> <p>Underbar ( _ ) and/or Overbar ( ¯ ) symbol may not be to scale.</p> |
|--|

# MIC4609

## 28-Lead SOICW Package Outline and Recommended Land Pattern



## APPENDIX A: REVISION HISTORY

### Revision C (September 2019)

- Updated [Equation 4-1](#).

### Revision B (November 2017)

- Packaging: Updated Part Marking Legend; Added note
- Corrected minor grammatical errors throughout document.
- Updated Media Type options in Product Information System.

### Revision A (March 2016)

- Original release of this document.

# MIC4609

---

NOTES:



## PRODUCT IDENTIFICATION SYSTEM

To order or obtain information, e.g., on pricing or delivery, refer to the factory or the listed sales office.

| <u>PART NO.</u>      | <u>X</u>           | <u>XX</u>  | <u>-XX<sup>(1)</sup></u> | <b>Examples:</b>  |
|----------------------|--------------------|--|--------------------------|---|
| <b>Device</b>        | <b>Lead Finish</b> | <b>Package Code</b>  | <b>Media Type</b>        |   |
| <b>Device:</b>       | MIC4609:           | 600V 3-Phase MOSFET/IGBT Driver                                |                          | a) MIC4609YWM: 600V 3-Phase MOSFET/IGBT Driver, Pb-Free Industrial Temperature, 28LD SOIC Wide Package, 27/Tube   |
| <b>Lead Finish:</b>  | Y:                 | Pb-Free with Industrial Temperature Grade                      |                          | b) MIC4609YWM-TR: 600V 3-Phase MOSFET/IGBT Driver, Pb-Free Industrial Temperature, 28LD SOIC Wide Package, 1,000/Reel   |
| <b>Package Code:</b> | WM:                | Plastic Small Outline, 7.52 mm Body, 28-Lead SOIC Wide Package |                          | <b>Note 1:</b> Tape and Reel identifier only appears in the catalog part number description. This identifier is used for ordering purposes and is not printed on the device package. Check with your Microchip Sales Office for package availability with the Tape and Reel option. |
| <b>Media Type:</b>   | <blank>:<br>TR:    | 27/Tube<br>1,000/Reel  |                          |   |

# MIC4609

---

NOTES:

---

---

**Note the following details of the code protection feature on Microchip devices:**

- Microchip products meet the specification contained in their particular Microchip Data Sheet.
- Microchip believes that its family of products is one of the most secure families of its kind on the market today, when used in the intended manner and under normal conditions.
- There are dishonest and possibly illegal methods used to breach the code protection feature. All of these methods, to our knowledge, require using the Microchip products in a manner outside the operating specifications contained in Microchip's Data Sheets. Most likely, the person doing so is engaged in theft of intellectual property.
- Microchip is willing to work with the customer who is concerned about the integrity of their code.
- Neither Microchip nor any other semiconductor manufacturer can guarantee the security of their code. Code protection does not mean that we are guaranteeing the product as “unbreakable.”

Code protection is constantly evolving. We at Microchip are committed to continuously improving the code protection features of our products. Attempts to break Microchip's code protection feature may be a violation of the Digital Millennium Copyright Act. If such acts allow unauthorized access to your software or other copyrighted work, you may have a right to sue for relief under that Act.

---

Information contained in this publication regarding device applications and the like is provided only for your convenience and may be superseded by updates. It is your responsibility to ensure that your application meets with your specifications. MICROCHIP MAKES NO REPRESENTATIONS OR WARRANTIES OF ANY KIND WHETHER EXPRESS OR IMPLIED, WRITTEN OR ORAL, STATUTORY OR OTHERWISE, RELATED TO THE INFORMATION, INCLUDING BUT NOT LIMITED TO ITS CONDITION, QUALITY, PERFORMANCE, MERCHANTABILITY OR FITNESS FOR PURPOSE. Microchip disclaims all liability arising from this information and its use. Use of Microchip devices in life support and/or safety applications is entirely at the buyer's risk, and the buyer agrees to defend, indemnify and hold harmless Microchip from any and all damages, claims, suits, or expenses resulting from such use. No licenses are conveyed, implicitly or otherwise, under any Microchip intellectual property rights unless otherwise stated.

#### **Trademarks**

The Microchip name and logo, the Microchip logo, Adaptec, AnyRate, AVR, AVR logo, AVR Freaks, BesTime, BitCloud, chipKIT, chipKIT logo, CryptoMemory, CryptoRF, dsPIC, FlashFlex, flexPWR, HELDO, IGLOO, JukeBlox, KeeLoq, Klear, LANCheck, LinkMD, maXStylus, maXTouch, MediaLB, megaAVR, Microsemi, Microsemi logo, MOST, MOST logo, MPLAB, OptoLyzer, PackeTime, PIC, picoPower, PICSTART, PIC32 logo, PolarFire, Prochip Designer, QTouch, SAM-BA, SenGenuity, SpyNIC, SST, SST Logo, SuperFlash, Symmetricom, SyncServer, Tachyon, TempTrackr, TimeSource, tinyAVR, UNI/O, Vectron, and XMEGA are registered trademarks of Microchip Technology Incorporated in the U.S.A. and other countries.

APT, ClockWorks, The Embedded Control Solutions Company, EtherSynch, FlashTec, Hyper Speed Control, HyperLight Load, IntelliMOS, Libero, motorBench, mTouch, Powermite 3, Precision Edge, ProASIC, ProASIC Plus, ProASIC Plus logo, Quiet-Wire, SmartFusion, SyncWorld, Temux, TimeCesium, TimeHub, TimePictra, TimeProvider, Vite, WinPath, and ZL are registered trademarks of Microchip Technology Incorporated in the U.S.A.

Adjacent Key Suppression, AKS, Analog-for-the-Digital Age, Any Capacitor, AnyIn, AnyOut, BlueSky, BodyCom, CodeGuard, CryptoAuthentication, CryptoAutomotive, CryptoCompanion, CryptoController, dsPICDEM, dsPICDEM.net, Dynamic Average Matching, DAM, ECAN, EtherGREEN, In-Circuit Serial Programming, ICSP, INICnet, Inter-Chip Connectivity, JitterBlocker, KlearNet, KlearNet logo, memBrain, Mindi, MiWi, MPASM, MPF, MPLAB Certified logo, MPLIB, MPLINK, MultiTRAK, NetDetach, Omniscient Code Generation, PICDEM, PICDEM.net, PICKit, PICtail, PowerSmart, PureSilicon, QMatrix, REAL ICE, Ripple Blocker, SAM-ICE, Serial Quad I/O, SMART-I.S., SQI, SuperSwitcher, SuperSwitcher II, Total Endurance, TSHARC, USBCheck, VariSense, ViewSpan, WiperLock, Wireless DNA, and ZENA are trademarks of Microchip Technology Incorporated in the U.S.A. and other countries.

SQTP is a service mark of Microchip Technology Incorporated in the U.S.A.

The Adaptec logo, Frequency on Demand, Silicon Storage Technology, and Symmcom are registered trademarks of Microchip Technology Inc. in other countries.

GestIC is a registered trademark of Microchip Technology Germany II GmbH & Co. KG, a subsidiary of Microchip Technology Inc., in other countries.

All other trademarks mentioned herein are property of their respective companies.

© 2019, Microchip Technology Incorporated, All Rights Reserved.

ISBN: 978-1-5224-5065-8

For information regarding Microchip's Quality Management Systems, please visit [www.microchip.com/quality](http://www.microchip.com/quality).



# MICROCHIP

## Worldwide Sales and Service

### AMERICAS

**Corporate Office**  
2355 West Chandler Blvd.  
Chandler, AZ 85224-6199  
Tel: 480-792-7200  
Fax: 480-792-7277  
Technical Support:  
<http://www.microchip.com/support>  
Web Address:  
[www.microchip.com](http://www.microchip.com)

#### Atlanta

Duluth, GA  
Tel: 678-957-9614  
Fax: 678-957-1455

#### Austin, TX

Tel: 512-257-3370

#### Boston

Westborough, MA  
Tel: 774-760-0087  
Fax: 774-760-0088

#### Chicago

Itasca, IL  
Tel: 630-285-0071  
Fax: 630-285-0075

#### Dallas

Addison, TX  
Tel: 972-818-7423  
Fax: 972-818-2924

#### Detroit

Novi, MI  
Tel: 248-848-4000

#### Houston, TX

Tel: 281-894-5983

#### Indianapolis

Noblesville, IN  
Tel: 317-773-8323  
Fax: 317-773-5453  
Tel: 317-536-2380

#### Los Angeles

Mission Viejo, CA  
Tel: 949-462-9523  
Fax: 949-462-9608  
Tel: 951-273-7800

#### Raleigh, NC

Tel: 919-844-7510

#### New York, NY

Tel: 631-435-6000

#### San Jose, CA

Tel: 408-735-9110  
Tel: 408-436-4270

#### Canada - Toronto

Tel: 905-695-1980  
Fax: 905-695-2078

### ASIA/PACIFIC

**Australia - Sydney**  
Tel: 61-2-9868-6733

**China - Beijing**  
Tel: 86-10-8569-7000

**China - Chengdu**  
Tel: 86-28-8665-5511

**China - Chongqing**  
Tel: 86-23-8980-9588

**China - Dongguan**  
Tel: 86-769-8702-9880

**China - Guangzhou**  
Tel: 86-20-8755-8029

**China - Hangzhou**  
Tel: 86-571-8792-8115

**China - Hong Kong SAR**  
Tel: 852-2943-5100

**China - Nanjing**  
Tel: 86-25-8473-2460

**China - Qingdao**  
Tel: 86-532-8502-7355

**China - Shanghai**  
Tel: 86-21-3326-8000

**China - Shenyang**  
Tel: 86-24-2334-2829

**China - Shenzhen**  
Tel: 86-755-8864-2200

**China - Suzhou**  
Tel: 86-186-6233-1526

**China - Wuhan**  
Tel: 86-27-5980-5300

**China - Xian**  
Tel: 86-29-8833-7252

**China - Xiamen**  
Tel: 86-592-2388138

**China - Zhuhai**  
Tel: 86-756-3210040

### ASIA/PACIFIC

**India - Bangalore**  
Tel: 91-80-3090-4444

**India - New Delhi**  
Tel: 91-11-4160-8631

**India - Pune**  
Tel: 91-20-4121-0141

**Japan - Osaka**  
Tel: 81-6-6152-7160

**Japan - Tokyo**  
Tel: 81-3-6880-3770

**Korea - Daegu**  
Tel: 82-53-744-4301

**Korea - Seoul**  
Tel: 82-2-554-7200

**Malaysia - Kuala Lumpur**  
Tel: 60-3-7651-7906

**Malaysia - Penang**  
Tel: 60-4-227-8870

**Philippines - Manila**  
Tel: 63-2-634-9065

**Singapore**  
Tel: 65-6334-8870

**Taiwan - Hsin Chu**  
Tel: 886-3-577-8366

**Taiwan - Kaohsiung**  
Tel: 886-7-213-7830

**Taiwan - Taipei**  
Tel: 886-2-2508-8600

**Thailand - Bangkok**  
Tel: 66-2-694-1351

**Vietnam - Ho Chi Minh**  
Tel: 84-28-5448-2100

### EUROPE

**Austria - Wels**  
Tel: 43-7242-2244-39  
Fax: 43-7242-2244-393

**Denmark - Copenhagen**  
Tel: 45-4450-2828  
Fax: 45-4485-2829

**Finland - Espoo**  
Tel: 358-9-4520-820

**France - Paris**  
Tel: 33-1-69-53-63-20  
Fax: 33-1-69-30-90-79

**Germany - Garching**  
Tel: 49-8931-9700

**Germany - Haan**  
Tel: 49-2129-3766400

**Germany - Heilbronn**  
Tel: 49-7131-72400

**Germany - Karlsruhe**  
Tel: 49-721-625370

**Germany - Munich**  
Tel: 49-89-627-144-0  
Fax: 49-89-627-144-44

**Germany - Rosenheim**  
Tel: 49-8031-354-560

**Israel - Ra'anana**  
Tel: 972-9-744-7705

**Italy - Milan**  
Tel: 39-0331-742611  
Fax: 39-0331-466781

**Italy - Padova**  
Tel: 39-049-7625286

**Netherlands - Drunen**  
Tel: 31-416-690399  
Fax: 31-416-690340

**Norway - Trondheim**  
Tel: 47-7288-4388

**Poland - Warsaw**  
Tel: 48-22-3325737

**Romania - Bucharest**  
Tel: 40-21-407-87-50

**Spain - Madrid**  
Tel: 34-91-708-08-90  
Fax: 34-91-708-08-91

**Sweden - Gothenberg**  
Tel: 46-31-704-60-40

**Sweden - Stockholm**  
Tel: 46-8-5090-4654

**UK - Wokingham**  
Tel: 44-118-921-5800  
Fax: 44-118-921-5820