

DO NOT SCALE FROM THIS PRINT

NOTES:

1. Ⓢ REPRESENTS A CRITICAL DIMENSION.
2. LATCH RETENTION FORCE: 2.22N [.5LB]
3. PARTS TO BE PACKAGED IN TUBES.
4. MEASUREMENTS TO BE MEASURED IN ZONE A.

DESIGNED & DIMENSIONED IN MILLIMETERS [INCHES]

ISD2-XX-D-X

No OF POSITIONS
-02 THRU -50
(PER ROW)

OPTION
-M: METAL RETENTION LATCH
-S: DUAL SCREW DOWN

ROW SPECIFICATION
-D: DOUBLE ROW

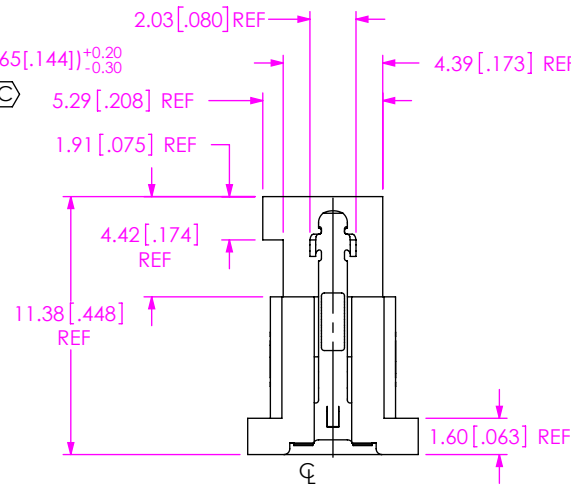
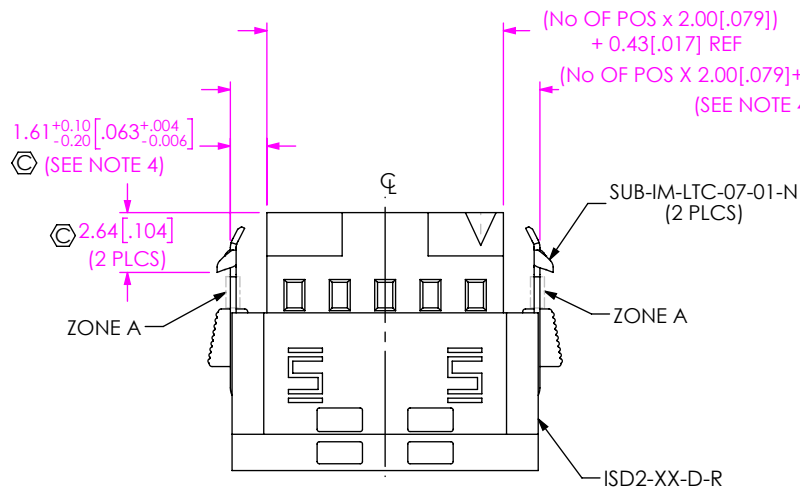
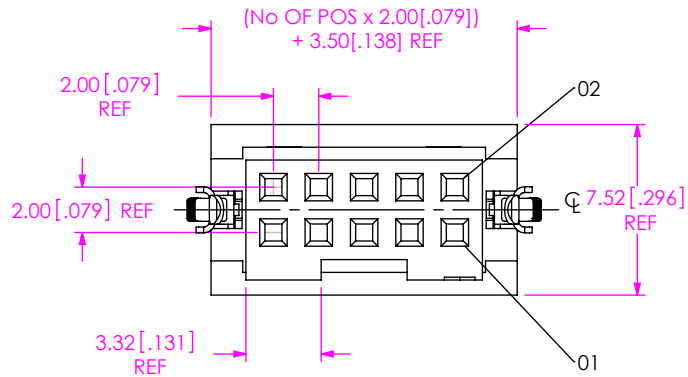
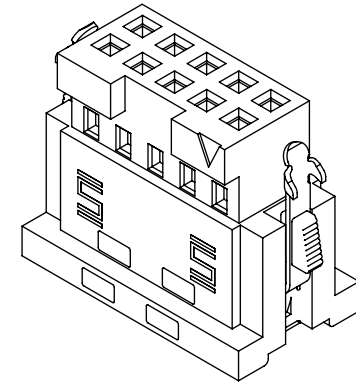

PACKAGING VIEW

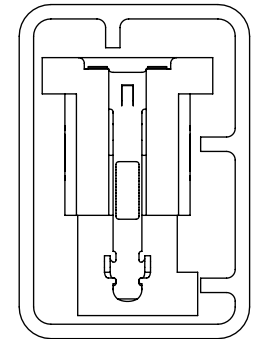

TUBE:PT-1-24-02-44
PLUG:TP-07

FIG 1
ISD2-05-D-M SHOWN

UNLESS OTHERWISE SPECIFIED, DIMENSIONS ARE IN MILLIMETERS. TOLERANCES ARE:
DECIMALS ANGLES
X.X: ± 0.3 [.01] 2°
X.XX: ± 0.13 [.005]
X.XXX: ± 0.051 [.0020]

PROPRIETARY NOTE
THIS DOCUMENT CONTAINS CONFIDENTIAL AND PROPRIETARY INFORMATION AND ALL DESIGN, MANUFACTURING, REPRODUCTION, USE, PATENT RIGHTS AND SALES RIGHTS ARE EXPRESSLY RESERVED BY SAMTEC, INC. THIS DOCUMENT SHALL NOT BE DISCLOSED, IN WHOLE OR PART, TO ANY UNAUTHORIZED PERSON OR ENTITY NOR REPRODUCED, TRANSFERRED OR INCORPORATED IN ANY OTHER PROJECT IN ANY MANNER WITHOUT THE EXPRESS WRITTEN CONSENT OF SAMTEC, INC.

samtec
520 PARK EAST BLVD. NEW ALBANY, IN 47150
PHONE: 812-944-6733 FAX: 812-948-5047
e-Mail: info@SAMTEC.com code 55322

MATERIAL: DO NOT SCALE DRAWING SHEET SCALE: 3:1
INSULATOR: LCP, COLOR: BLACK
LATCH STAMPING: BeCu
LATCH OVERMOLDING: NYLON, COLOR: WHITE
BUTTON: NYLON, COLOR: WHITE

DESCRIPTION: 2mm DISCRETE WIRE INSULATOR & LATCH ASM

DWG. NO. **ISD2-XX-D-X**

BY: J. BROWNING 02/22/2010 SHEET 1 OF 2

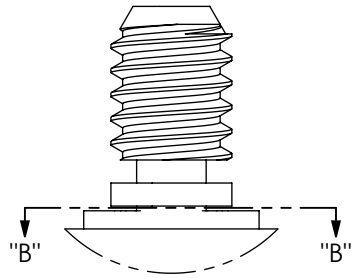

DETAIL 'A'
SCALE 8 : 1

R1.45[.057] REF

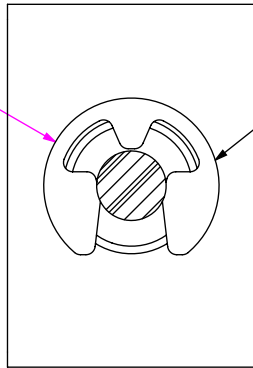

SECTION "B"-
SCALE 8 : 1

ACCRT-01

'A'

CPS-RR-M2-01-X

ISD2-XX-D-DS

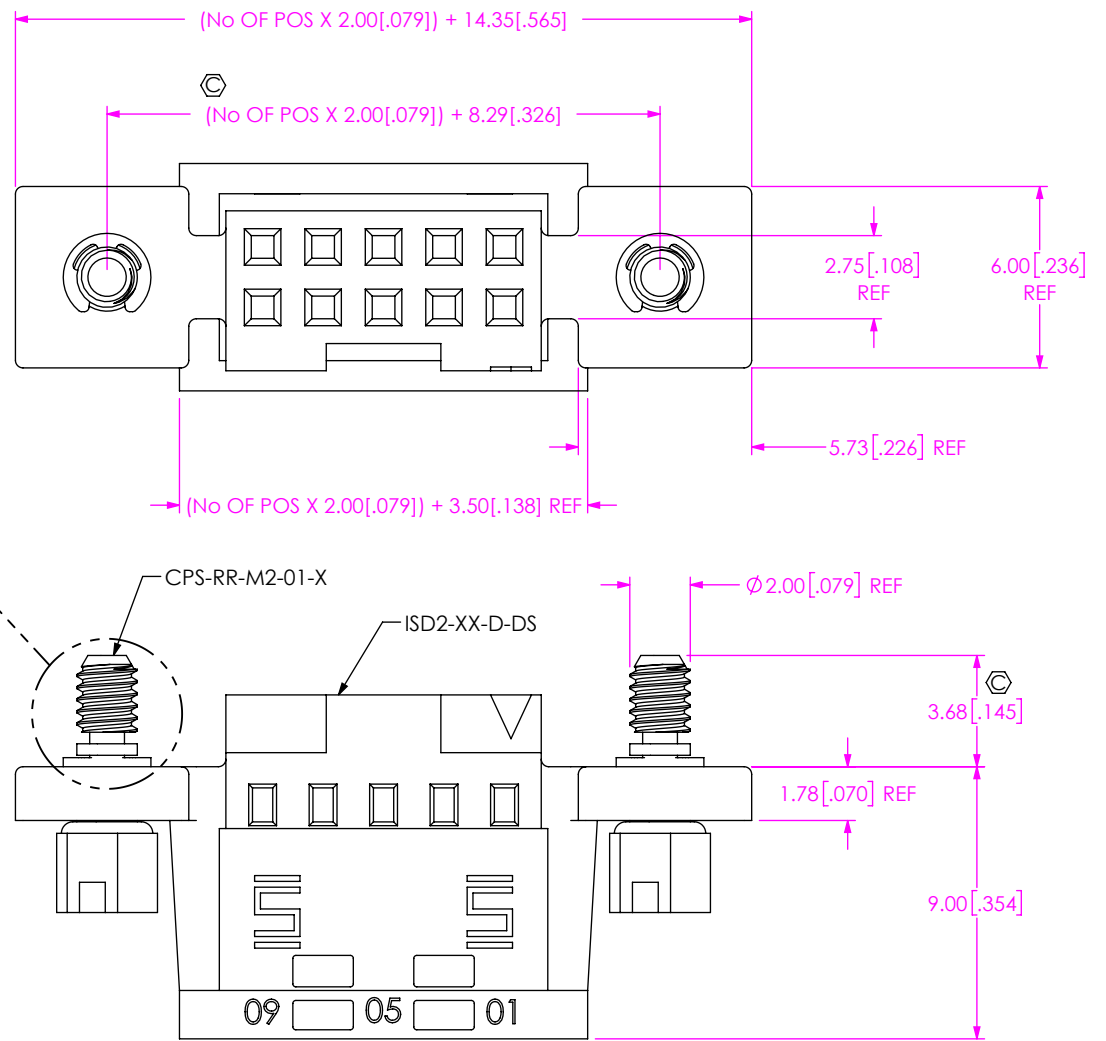
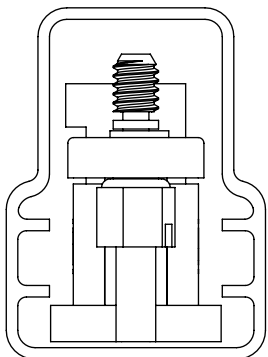

FIG 2
-S: DUAL SCREW DOWN OPTION
ISD2-05-D-S SHOWN
(DIFFERENT AS SHOWN, OTHERWISE SAME AS FIG 1)

PACKAGING VIEW
-S OPTION



TUBE:PT-SEAMP003-6
PLUG:TP-07

PROPRIETARY NOTE
THIS DOCUMENT CONTAINS CONFIDENTIAL AND PROPRIETARY INFORMATION AND ALL DESIGN, MANUFACTURING, REPRODUCTION, USE, PATENT RIGHTS AND SALES RIGHTS ARE EXPRESSLY RESERVED BY SAMTEC, INC. THIS DOCUMENT SHALL NOT BE DISCLOSED, IN WHOLE OR PART, TO ANY UNAUTHORIZED PERSON OR ENTITY NOR REPRODUCED, TRANSFERRED OR INCORPORATED IN ANY OTHER PROJECT IN ANY MANNER WITHOUT THE EXPRESS WRITTEN CONSENT OF SAMTEC, INC.

DO NOT SCALE DRAWING

SHEET SCALE: 2:1



520 PARK EAST BLVD, NEW ALBANY, IN 47150
PHONE: 812-944-6733 FAX: 812-948-5047
e-Mail info@SAMTEC.com code 55322

DESCRIPTION:
2mm DISCRETE WIRE INSULATOR & LATCH ASM

DWG. NO. ISD2-XX-D-X

BY: J. BROWNING 02/22/2010 SHEET 2 OF 2