

CHARACTERISSTICS

MATERIALS

- SHELL : BRASS
- SHELL PLATING : NICKEL
- NUT : BRASS
- NUT PLATING : NICKEL
- LATCH SLEEVE : BRASS
- LATCH SLEEVE PLATING : NICKEL
- CONTACTS : COPPER ALLOY
- CONTACT PLATING : 7µ" GOLD PLATED OVER 196µ" NICKEL MIN.
- INSULATOR : PPS (HIGH TEMPERATURE)

MECHANICAL

- DURABILITY: 5000 CYCLES
- OPERATING TEMP. RANGE: -40° C ~ +200° C
- PROCESS TEMPERATURE : 260° C FOR 5 SECONDS
- MAX. TORQUE VALUE : 6.0 Nm [53 IN/lbs]
- SHIELDING: 75dB @ 10MHz
- 40dB @ 1GHz

IP RATING: 50

822B R YY - 2 1 3 R 00 1

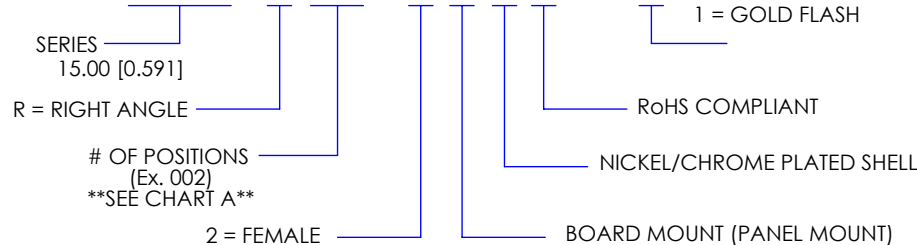
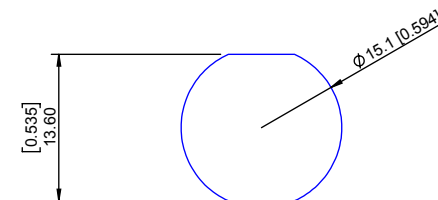

CHART A

● = KEY LOCATION

\*\*VIEW FROM TERMINATION END\*\*

 2 POSITION 12 AMP MAX. PIN Ø = 2.00 [0.079]  CONTACT RESISTANCE = 3 mΩ TEST VOLTAGE = 2100V WORKING VOLTAGE = 700V	 3 POSITION 12 AMP MAX. PIN Ø = 1.60 [0.063]  CONTACT RESISTANCE = 4 mΩ TEST VOLTAGE = 2400V WORKING VOLTAGE = 800V	 4 POSITION 12 AMP MAX. PIN Ø = 1.30 [0.051]  CONTACT RESISTANCE = 5 mΩ TEST VOLTAGE = 1850V WORKING VOLTAGE = 610V	 6 POSITION 12 AMP MAX. PIN Ø = 1.30 [0.051]  CONTACT RESISTANCE = 5 mΩ TEST VOLTAGE = 1350V WORKING VOLTAGE = 450V	 8 POSITION 6 AMP MAX. PIN Ø = 0.90 [0.035]  CONTACT RESISTANCE = 6 mΩ TEST VOLTAGE = 1500V WORKING VOLTAGE = 500V	
 10 POSITION 6 AMP MAX. PIN Ø = 0.90 [0.035]  CONTACT RESISTANCE = 6 mΩ TEST VOLTAGE = 1450V WORKING VOLTAGE = 500V	 12 POSITION 6 AMP MAX. PIN Ø = 0.70 [0.028]  CONTACT RESISTANCE = 7.5 mΩ TEST VOLTAGE = 1250V WORKING VOLTAGE = 480V	 14 POSITION 6 AMP MAX. PIN Ø = 0.70 [0.028]  CONTACT RESISTANCE = 7.5 mΩ TEST VOLTAGE = 1150V WORKING VOLTAGE = 380V	 16 POSITION 6 AMP MAX. PIN Ø = 0.70 [0.028]  CONTACT RESISTANCE = 7.5 mΩ TEST VOLTAGE = 950V WORKING VOLTAGE = 315V	 19 POSITION 5 AMP MAX. PIN Ø = 0.70 [0.028]  CONTACT RESISTANCE = 7.5 mΩ TEST VOLTAGE = 950V WORKING VOLTAGE = 315V	 26 POSITION 2 AMP MAX. PIN Ø = 0.50 [0.020]  CONTACT RESISTANCE = 10 mΩ TEST VOLTAGE = 950V WORKING VOLTAGE = 315V



PANEL CUTOUT

TOLERANCE = +0.10, -0.0  
[+0.004, -0.00]

\*\*NOTE\*\*

SEE PAGE 2 FOR BOARD LAYOUTS

RoHS COMPLIANT



THESE DRAWINGS AND SPECIFICATIONS ARE THE PROPERTY OF NorComp AND SHALL NOT BE REPRODUCED, COPIED OR USED AS THE BASIS FOR THE MANUFACTURE OR SALE OF APPARATUS WITHOUT WRITTEN PERMISSION.

NorComp

DRAWN: M. SIGMON	DATE: 02-15-16	SCALE: N.T.S.	SHEET 1	OF 2	REV: 3
			DWG NO. 822BRY-213R001		

# BOARD LAYOUTS (TOP VIEW)

● = KEY LOCATION / PCB EDGE

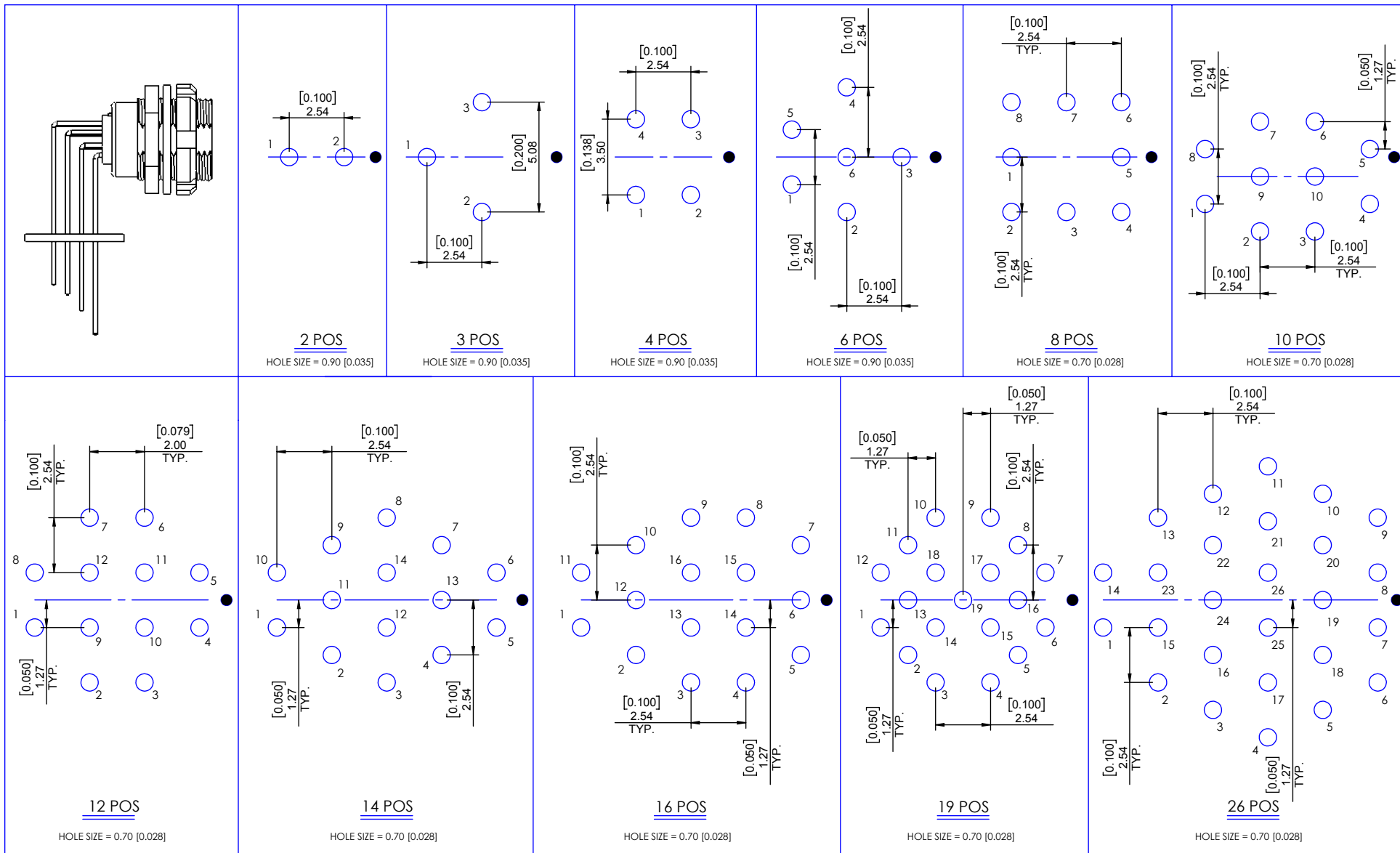

**RoHS COMPLIANT**



THESE DRAWINGS AND SPECIFICATIONS ARE THE PROPERTY OF NorComp AND SHALL NOT BE REPRODUCED, COPIED OR USED AS THE BASIS FOR THE MANUFACTURE OR SALE OF APPARATUS WITHOUT WRITTEN PERMISSION.

# NorComp

DRAWN: M. SIGMON

DATE: 02-10-16

SCALE: N.T.S.

SHEET 2 OF 2

REV: 3

DWG NO. 822BRYY-213R001