

**512Kx8 HIGH SPEED AYNCHRONOUS
 CMOS STATIC RAM**

KEY FEATURES

- High-speed access time: 8, 10ns, 12ns
- Low Active Current: 35mA (Max., 10ns, I-temp)
- Low Standby Current: 10 mA (Max., I-temp)
- Single power supply
 - 1.65V-2.2V V_{DD}(IS61/64WV5128FALL)
 - 2.4V-3.6V V_{DD} (IS61/64WV5128FBLL)
- Three state outputs
- Industrial and Automotive temperature support
- Lead-free available

FUNCTIONAL BLOCK DIAGRAM

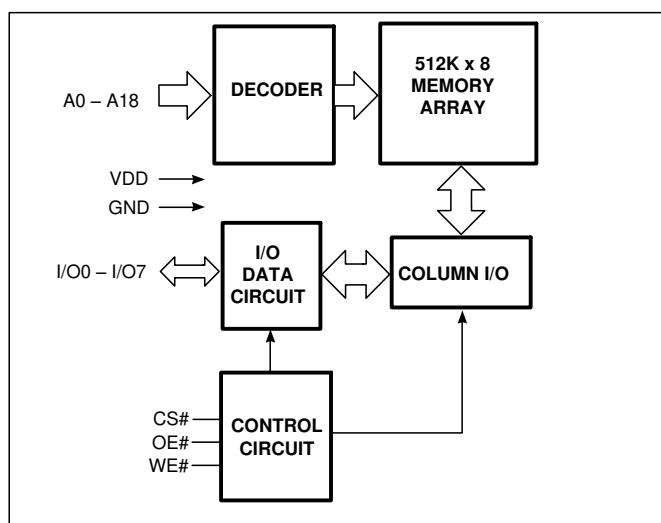

DESCRIPTION

The *ISSI* IS61/64WV5128FALL/FBLL are high-speed, low power, 4M bit static RAMs organized as 512K words by 8 bits. It is fabricated using *ISSI*'s high-performance CMOS technology.

This highly reliable process coupled with innovative circuit design techniques, yields high-performance and low power devices.

When CS# is HIGH (deselected), the device assumes a standby mode at which the power dissipation can be reduced down with CMOS input levels.

Easy memory expansion is provided by using Chip Enable and Output Enable inputs. The active LOW Write Enable (WE#) controls both writing and reading of the memory.

The IS61/64WV5128FALL/FBLL are packaged in the JEDEC standard 44-pin TSOP (TYPE II), 36-pin SOJ and 36-ball mini BGA (6mm x 8mm).

Copyright © 2018 Integrated Silicon Solution, Inc. All rights reserved. ISSI reserves the right to make changes to this specification and its products at any time without notice. ISSI assumes no liability arising out of the application or use of any information, products or services described herein. Customers are advised to obtain the latest version of this device specification before relying on any published information and before placing orders for products.

Integrated Silicon Solution, Inc. does not recommend the use of any of its products in life support applications where the failure or malfunction of the product can reasonably be expected to cause failure of the life support system or to significantly affect its safety or effectiveness. Products are not authorized for use in such applications unless Integrated Silicon Solution, Inc. receives written assurance to its satisfaction, that:

- a.) the risk of injury or damage has been minimized;
- b.) the user assume all such risks; and
- c.) potential liability of Integrated Silicon Solution, Inc is adequately protected under the circumstances

PIN CONFIGURATIONS

36-Pin SOJ (Package Code: K)

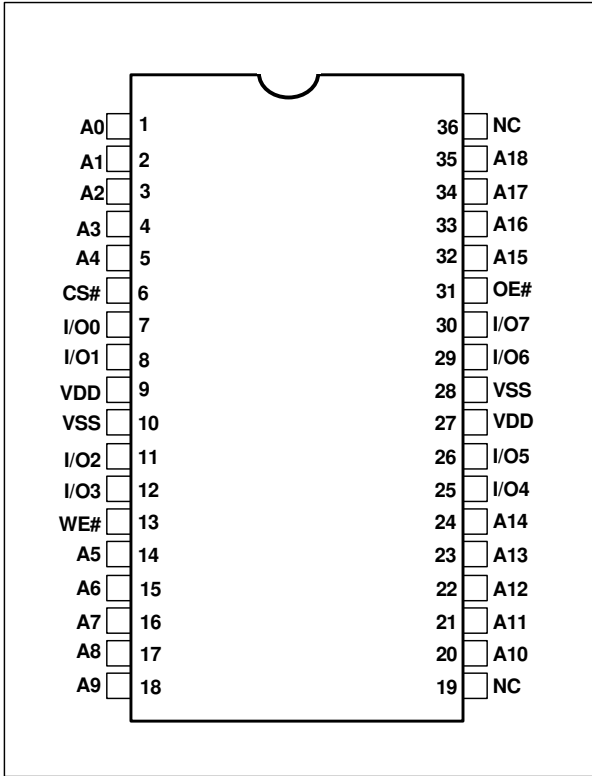

44-Pin TSOP-II (Package Code: T)

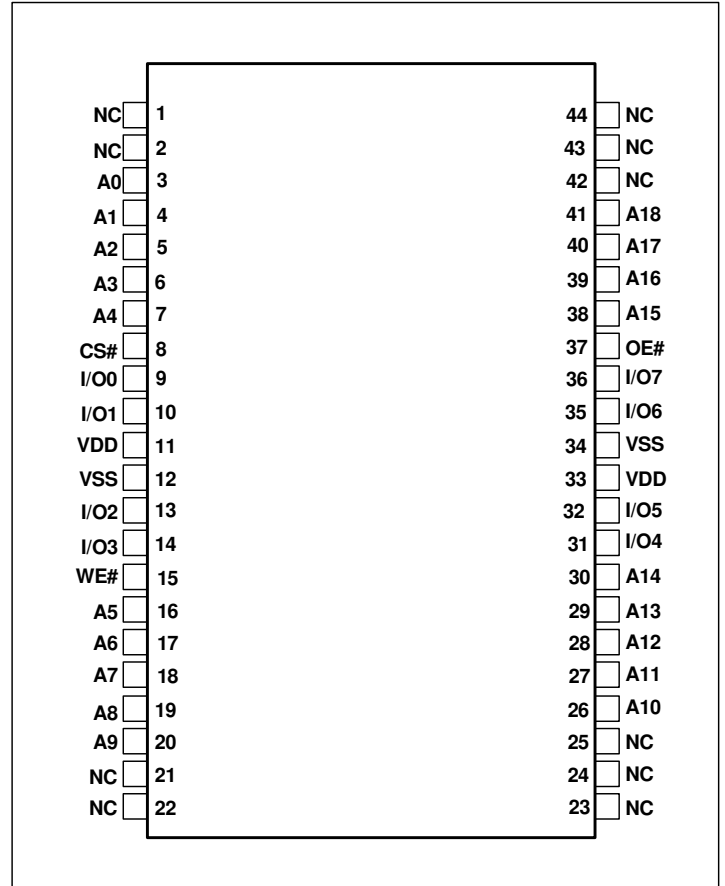

36-Ball mini BGA (6mm x 8mm) (Package Code: B)

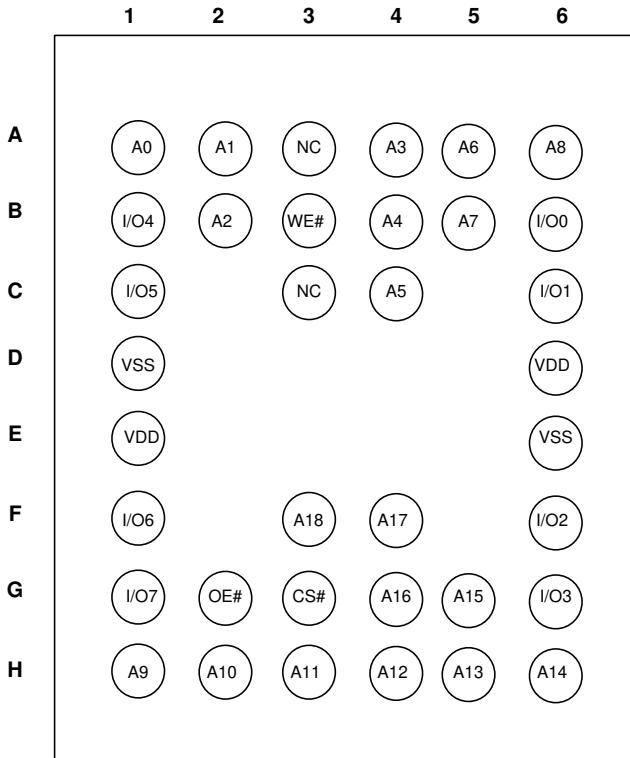

PIN DESCRIPTIONS

A0-A18	Address Inputs
I/O0-I/O7	Data Inputs/Outputs
CS#	Chip Enable Input
OE#	Output Enable Input
WE#	Write Enable Input
NC	No Connection
VDD	Power
VSS	Ground

FUNCTION DESCRIPTION

SRAM is one of random access memories. Each byte has an address and can be accessed randomly. SRAM has three different modes supported. Each function is described below with Truth Table.

STANDBY MODE

Device enters standby mode when deselected (CS# HIGH). The input and output pins (I/O0-7) are placed in a high impedance state. CMOS input in this mode will maximize saving power.

WRITE MODE

Write operation issues with Chip selected (CS#) and Write Enable (WE#) input LOW. The input and output pins (I/O0-7) are in data input mode. Output buffers are closed during this time even if OE# is LOW.

READ MODE

Read operation issues with Chip selected (CS# LOW) and Write Enable (WE#) input HIGH. When OE# is LOW, output buffer turns on to make data output. Any input to I/O pins during READ mode is not permitted.

In the READ mode, output buffers can be turned off by pulling OE# HIGH. In this mode, internal device operates as READ but I/Os are in a high impedance state. Since device is in READ mode, active current is used.

TRUTH TABLE

Mode	CS#	WE#	OE#	I/O Operation	VDD Current
Not Selected	H	X	X	High-Z	I _{SB1} , I _{SB2}
Output Disabled	L	H	H	High-Z	ICC, ICC1
Read	L	H	L	DOUT	ICC, ICC1
Write	L	L	X	DIN	ICC, ICC1

POWER UP INITIALIZATION

The device includes on-chip voltage sensor used to launch POWER-UP initialization process.

When VDD reaches stable level, the device requires 150us of t_{PU} (Power-Up Time) to complete its self-initialization process.

When initialization is complete, the device is ready for normal operation.

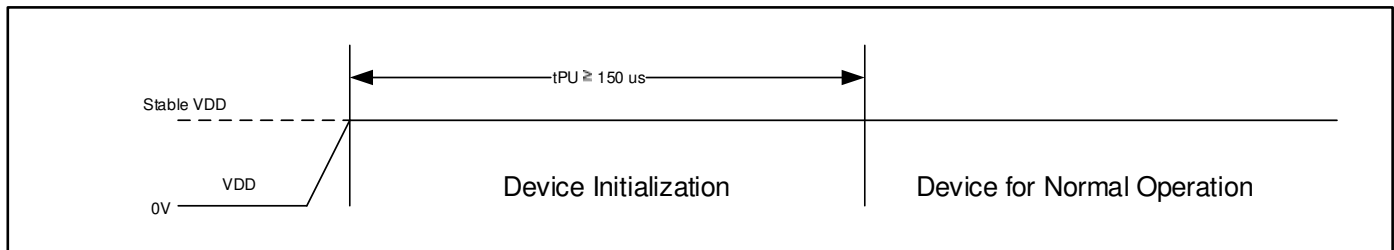

ABSOLUTE MAXIMUM RATINGS AND OPERATING RANGE

ABSOLUTE MAXIMUM RATINGS⁽¹⁾

Symbol	Parameter	Value	Unit
V _{term}	Terminal Voltage with Respect to VSS	-0.5 to V _{DD} + 0.5V	V
V _{DD}	V _{DD} Related to VSS	-0.3 to 4.0	V
t _{Stg}	Storage Temperature	-65 to +150	°C
P _T	Power Dissipation	1.0	W

Note:

1. Stress greater than those listed under ABSOLUTE MAXIMUM RATINGS may cause permanent damage to the device. This is a stress rating only and functional operation of the device at these or any other conditions above those indicated in the operational sections of this specification is not implied. Exposure to absolute maximum rating conditions for extended periods may affect reliability.

PIN CAPACITANCE ⁽¹⁾

Parameter	Symbol	Test Condition	Max	Units
Input capacitance	C _{IN}	T _A = 25°C, f = 1 MHz, V _{DD} = V _{DD} (typ)	6	pF
DQ capacitance (IO0–IO7)	C _{I/O}		8	pF

Note:

1. These parameters are guaranteed by design and tested by a sample basis only.

OPERATING RANGE⁽¹⁾

Range	Ambient Temperature	PART NUMBER	VDD	SPEED (MAX)
Commercial	0°C to +70°C	IS61WV5128FALL	1.65V – 2.2V	10 ns
		IS61WV5128FBLL	2.4V – 3.6V	
				3.3V+/-10%
Industrial	-40°C to +85°C	IS61WV5128FALL	1.65V – 2.2V	10 ns
		IS61WV5128FBLL	2.4V – 3.6V	
				3.3V+/-10%
Automotive (A3)	-40°C to +125°C	IS64WV5128FALL	1.65V – 2.2V	10 ns
		IS64WV5128FBLL	2.4V – 3.6V	

AC TEST CONDITIONS (OVER THE OPERATING RANGE)

Parameter	Unit (1.65V~2.2V)	Unit (2.4V~3.6V)	Unit (3.3V +/-10%)
Input Pulse Level	0V to V_{DD}	0V to V_{DD}	0V to V_{DD}
Input Rise and Fall Time	1.5 ns	1.5 ns	1.5 ns
Output Timing Reference Level	$\frac{1}{2} V_{DD}$	$\frac{1}{2} V_{DD}$	$\frac{1}{2} V_{DD}$
R1 (ohm)	13500	319	319
R2 (ohm)	10800	353	353
V_{TM} (V)	V_{DD}	V_{DD}	V_{DD}
Output Load Conditions	Refer to Figure 1 and 2		

AC TEST LOADS

FIGURE 1

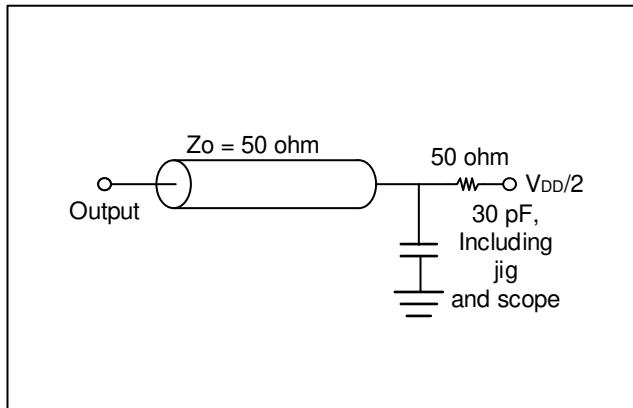
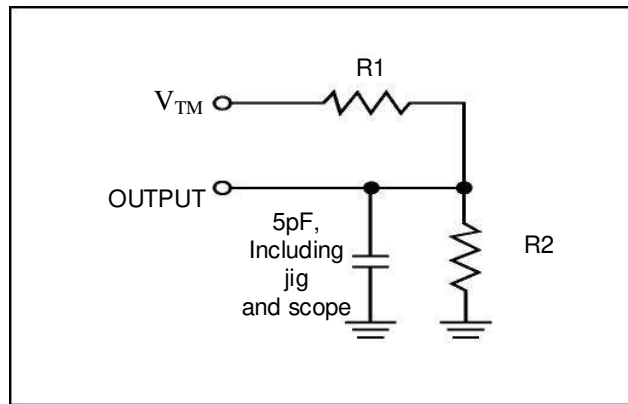

FIGURE 2



DC ELECTRICAL CHARACTERISTICS

DC ELECTRICAL CHARACTERISTICS (OVER THE OPERATING RANGE)

IS61/64WV5128FALL (VDD = 1.65V – 2.2V)

Symbol	Parameter	Test Conditions	Min.	Max.	Unit
V _{OH}	Output HIGH Voltage	I _{OH} = -0.1 mA	1.4	—	V
V _{OL}	Output LOW Voltage	I _{OL} = 0.1 mA	—	0.2	V
V _{IH} (¹)	Input HIGH Voltage		1.4	V _{DD} + 0.2	V
V _{IL} (¹)	Input LOW Voltage		-0.2	0.4	V
I _{LI}	Input Leakage	GND < V _{IN} < V _{DD}	-1	1	μA
I _{LO}	Output Leakage	GND < V _{IN} < V _{DD} , Output Disabled	-1	1	μA

Note:

- V_{ILL}(min) = -1.0V AC (pulse width < 10ns). Not 100% tested.
V_{IHH}(max) = V_{DD} + 1.0V AC (pulse width < 10ns). Not 100% tested.

IS61/64WV5128FBLL (VDD = 2.4V – 3.6V)

Symbol	Parameter	Test Conditions	Min.	Max.	Unit	
V _{OH}	Output HIGH Voltage	2.4V ~ 2.7V	V _{DD} = Min., I _{OH} = -1.0 mA	2.0	—	V
		2.7V ~ 3.6V	V _{DD} = Min., I _{OH} = -4.0 mA	2.2		
V _{OL}	Output LOW Voltage	2.4V ~ 2.7V	V _{DD} = Min., I _{OL} = 2.0 mA	—	0.4	V
		2.7V ~ 3.6V	V _{DD} = Min., I _{OL} = 8.0 mA	—	0.4	
V _{IH} (¹)	Input HIGH Voltage	2.4V ~ 2.7V		2.0	V _{DD} + 0.3	V
		2.7V ~ 3.6V		2.0		
V _{IL} (¹)	Input LOW Voltage	2.4V ~ 2.7V		-0.3	0.6	V
		2.7V ~ 3.6V		-0.3	0.8	
I _{LI}	Input Leakage	V _{SS} < V _{IN} < V _{DD}	-2	2	μA	
I _{LO}	Output Leakage	V _{SS} < V _{IN} < V _{DD} , Output Disabled	-2	2	μA	

Note:

- V_{IL}(min) = -0.3V DC ; V_{IL}(min) = -2.0V AC (pulse width 2.0ns). Not 100% tested.
V_{IH}(max) = V_{DD} + 0.3V DC ; V_{IH}(max) = V_{DD} + 2.0V AC (pulse width 2.0ns). Not 100% tested.

POWER SUPPLY CHARACTERISTICS-II FOR POWER (OVER THE OPERATING RANGE)

Symbol	Parameter	Test Conditions	Grade	-8 ⁽³⁾ Max.	-10 Max.	-12 Max.	Unit
ICC	V _{DD} Dynamic Operating Supply Current	V _{DD} = MAX, I _{OUT} = 0 mA, f = f _{MAX}	Com.	40	30	30	mA
			Ind.	45	35	35	
			Auto.	-	40	40	
ICC1	Operating Supply Current	V _{DD} = MAX, I _{OUT} = 0 mA, f = 0	Com.	20	20	20	mA
			Ind.	25	25	25	
			Auto.	-	35	35	
ISB1	TTL Standby Current (TTL Inputs)	V _{DD} = MAX, V _{IN} = V _{IH} or V _{IL} CS# ≥ V _{IH} , f = 0	Com.	15	15	15	mA
			Ind.	20	20	20	
			Auto.	-	30	30	
ISB2	CMOS Standby Current (CMOS Inputs)	V _{DD} = MAX, CS# ≥ V _{DD} - 0.2V V _{IN} ≥ V _{DD} - 0.2V, or V _{IN} ≤ 0.2V , f = 0	Com.	8	8	8	mA
			Ind.	10	10	10	
			Auto.	-	20	20	
			Typ. ⁽²⁾	3			

Notes:

1. At f = f_{MAX}, address and data inputs are cycling at the maximum frequency, f = 0 means no input line change.
2. Typical value indicate the value for the center of distribution, measured at V_{DD} = 3.0V/1.8V, T_A = 25 °C, and not 100% tested.
3. 8ns is at V_{DD}=3.3V +/-10%

AC CHARACTERISTICS (OVER OPERATING RANGE)

READ CYCLE AC CHARACTERISTICS

Parameter	Symbol	-8 ⁽³⁾		-10		-12		unit	notes
		Min	Min	Min	Min	Min	Max		
Read Cycle Time	tRC	8	-	10	-	12	-	ns	
Address Access Time	tAA	-	8	-	10	-	12	ns	
Output Hold Time	tOHA	2.0	-	2.5	-	2.5	-	ns	
CS# Access Time	tACE	-	8	-	10	-	12	ns	
OE# Access Time	tDOE	-	4.5	-	6	-	7	ns	
OE# to High-Z Output	tHZOE	0	3	0	5	0	6	ns	2
OE# to Low-Z Output	tLZOE	0	-	0	-	0	-	ns	2
CS# to High-Z Output	tHZCE	0	3	0	5	0	6	ns	2
CS# to Low-Z Output	tLZCE	3	-	3	-	3	-	ns	2

Notes:

1. Test conditions assume signal transition times of 1.5 ns or less, timing reference levels of $V_{DD}/2$, input pulse levels of 0V to V_{DD} and output loading specified in Figure 1.
2. Tested with the load in Figure 2. Transition is measured ± 500 mV from steady-state voltage. Not 100% tested.
3. 8ns is at $V_{DD}=3.3V \pm 10\%$

AC WAVEFORMS

READ CYCLE NO. 1^(1,2) (ADDRESS CONTROLLED, CS# = OE# = LOW, WE# = HIGH)

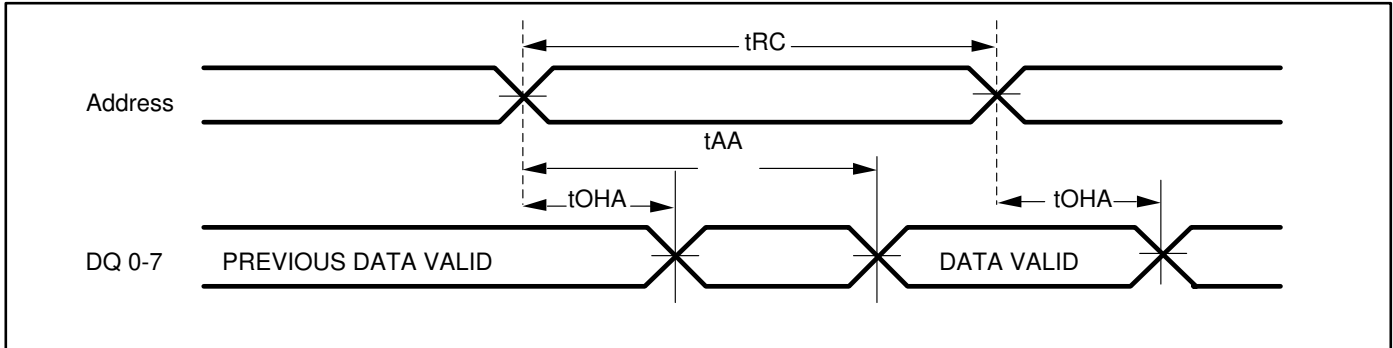

Notes:

1. The device is continuously selected.

READ CYCLE NO. 2⁽¹⁾ (OE# CONTROLLED, WE# = HIGH)

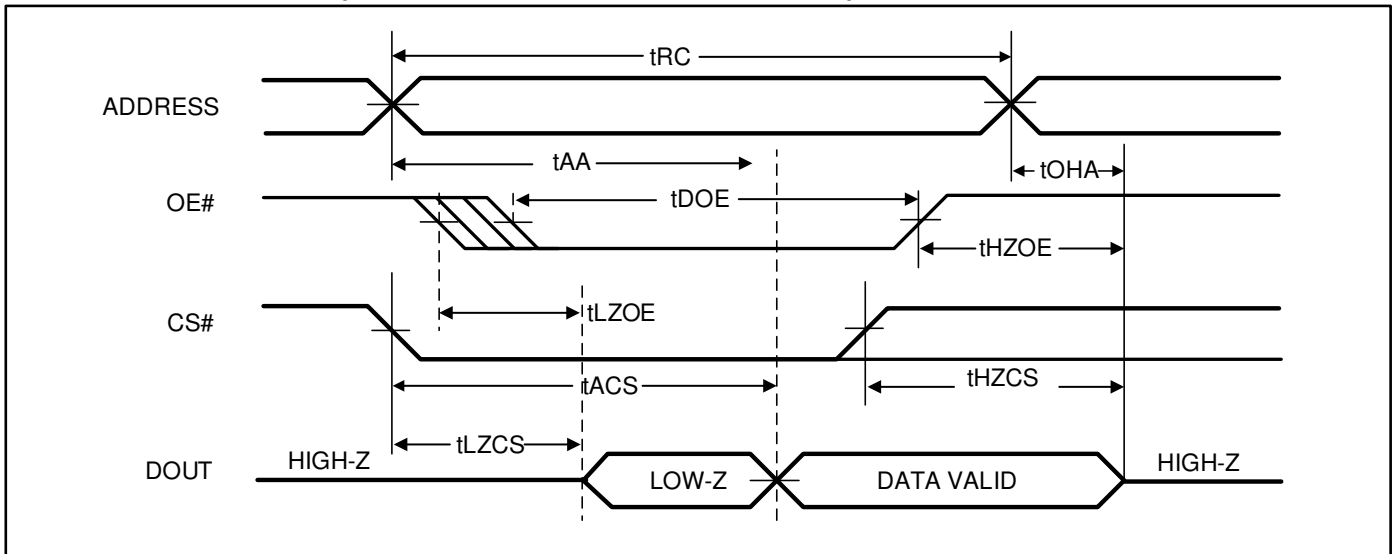

Note:

1. Address is valid prior to or coincident with CS# LOW transition.

WRITE CYCLE AC CHARACTERISTICS

Parameter	Symbol	-8 ⁽³⁾		-10		-12		unit	notes
		Min	Max	Min	Max	Min	Max		
Write Cycle Time	tWC	8	-	10	-	12	-	ns	
CS# to Write End	tSCS	6.5	-	8	-	9	-	ns	
Address Setup Time to Write End	tAW	6.5	-	8	-	9	-	ns	
Address Hold from Write End	tHA	0	-	0	-	0	-	ns	
Address Setup Time	tSA	0	-	0	-	0	-	ns	
WE# Pulse Width	tPWE1	6.5	-	8	-	9	-	ns	
WE# Pulse Width (OE# = LOW)	tPWE2	8	-	10	-	12	-	ns	2
Data Setup to Write End	tSD	5	-	6	-	7	-	ns	
Data Hold from Write End	tHD	0	-	0	-	0	-	ns	
WE# LOW to High-Z Output	tHZWE	-	3.5	-	4	-	5	ns	
WE# HIGH to Low-Z Output	tLZWE	2	-	2	-	2	-	ns	

Notes:

- 1 The internal write time is defined by the overlap of CS# = LOW, and WE# = LOW. All conditions must be in valid states to initiate a Write, but any condition can go inactive to terminate the Write. The Data Input Setup and Hold timing are referenced to the rising or falling edge of the signal that terminates the write.
- 2 tPWE > tHZWE + tSD when OE# is LOW.
- 3 8ns is at VDD=3.3V +/-10%

AC WAVEFORMS

WRITE CYCLE NO. 1⁽¹⁾ (CS# CONTROLLED, OE# = HIGH OR LOW)

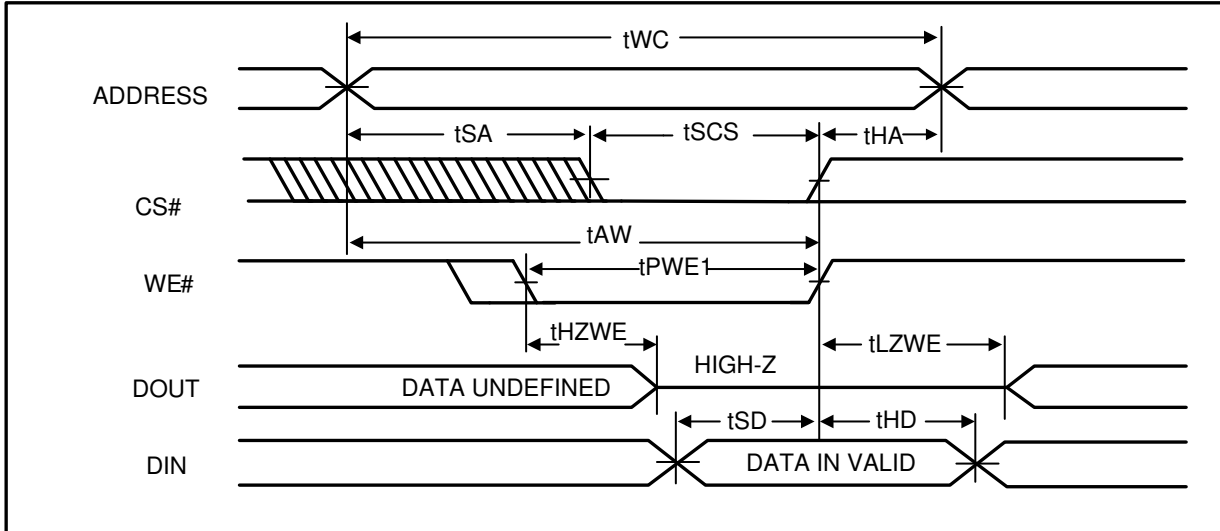

Note:

1. I/O will assume the High-Z state if CS# = V_{IH} or OE# = V_{IH}.

WRITE CYCLE NO. 2⁽¹⁾ (WE# CONTROLLED: OE# IS HIGH DURING WRITE CYCLE)

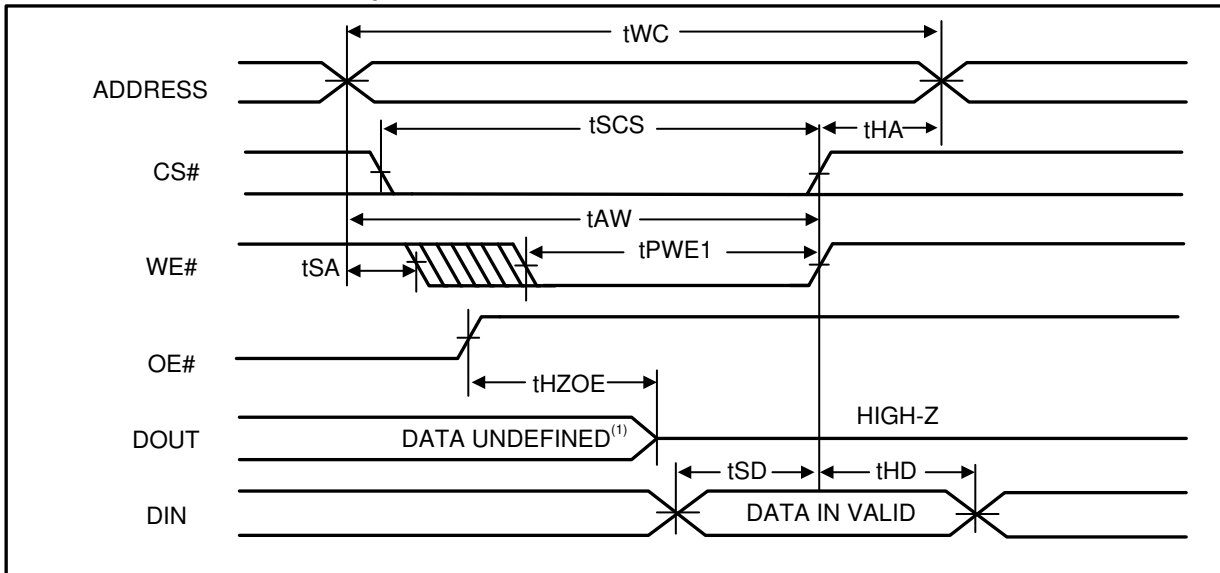

Note:

1. t_{HZOE} is the time DOUT goes to High-Z after OE# goes high. During this period the I/Os are in output state. Do not apply input signals.

WRITE CYCLE NO. 3⁽¹⁾ (WE# CONTROLLED: OE# IS LOW DURING WRITE CYCLE)

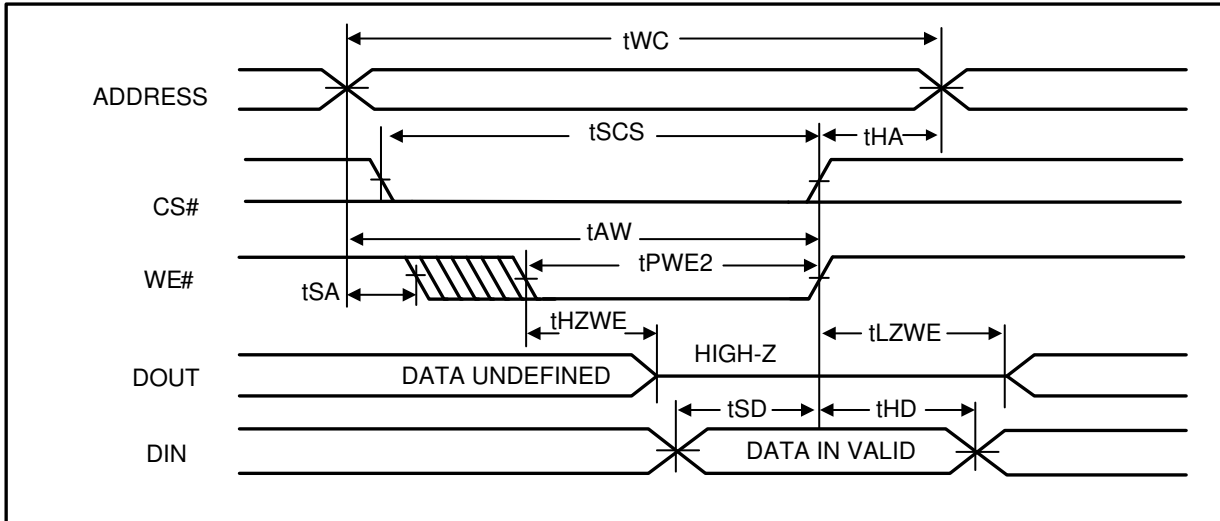

Note:

1. I/O will assume the High-Z state if CS# = V_{IH} or OE# = V_{IH} .

DATA RETENTION CHARACTERISTICS⁽²⁾

Symbol	Parameter	Test Condition	OPTION	Min.	Typ.	Max.	Unit
V _{DR}	V _{DD} for Data Retention	See Data Retention Waveform	V _{DD} = 2.4V to 3.6V	2.0		-	V
			V _{DD} = 1.65V to 2.2V	1.2		-	
I _{DR}	Data Retention Current	V _{DD} = V _{DR} (min.), CS# ≥ V _{DD} - 0.2V, VIN ≤ 0.2V or VIN ≥ V _{DD} - 0.2V	Com.	-	3 ⁽¹⁾	8	mA
			Ind.	-	-	10	
			Auto	-	-	20	
t _{SDR}	Data Retention Setup Time	See Data Retention Waveform		0	-	-	ns
t _{RDR}	Recovery Time	See Data Retention Waveform		t _{RC}	-	-	ns

Notes:

1. Typical value indicates the value for the center of distribution, measured at V_{DD} = V_{DR} (min.), T_A = 25 °C and not 100% tested.
2. VDD power down slope must be longer than 100 us/volt when enter into Data Retention Mode.

DATA RETENTION WAVEFORM (CS# CONTROLLED)

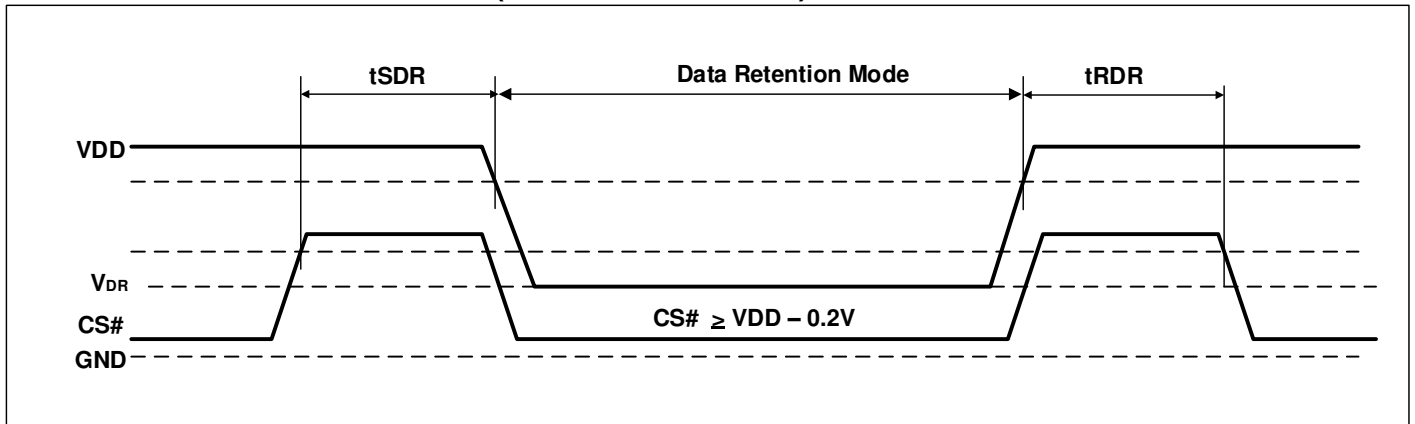

ORDERING INFORMATION

Industrial Range: -40°C to +85°C, Voltage Range: 1.65V to 2.2V

Speed (ns)	Order Part No.	Package
10	IS61WV5128FALL-10BI	36-ball mini BGA (6mm x 8mm)
10	IS61WV5128FALL-10BLI	36-ball mini BGA (6mm x 8mm), Lead-free
10	IS61WV5128FALL-10KLI	400-mil Plastic SOJ, Lead-free
10	IS61WV5128FALL-10TLI	TSOP (Type II) , Lead-free

Industrial Range: -40°C to +85°C, Voltage Range: 2.4V to 3.6V

Speed (ns) ⁽¹⁾	Order Part No.	Package
10 (8)	IS61WV5128FBLL-10BI	36-ball mini BGA (6mm x 8mm)
10 (8)	IS61WV5128FBLL-10BLI	36-ball mini BGA (6mm x 8mm), Lead-free
10 (8)	IS61WV5128FBLL-10KLI	400-mil Plastic SOJ, Lead-free
10 (8)	IS61WV5128FBLL-10TLI	TSOP (Type II) , Lead-free

Note:

1. Speed = 8ns when VDD = 3.3V +/-10%. Speed = 10ns when VDD = 2.4V to 3.6V

Automotive (A3) Range: -40°C to +125°C, Voltage Range: 1.65V to 2.2V

Speed (ns)	Order Part No.	Package
12	IS64WV5128FALL-12BA3	36-ball mini BGA (6mm x 8mm)
12	IS64WV5128FALL-12BLA3	36-ball mini BGA (6mm x 8mm), Lead-free
12	IS64WV5128FALL-12KLA3	400-mil Plastic SOJ, Lead-free
12	IS64WV5128FALL-12CTLA3	TSOP (Type II) , Lead-free

Automotive (A3) Range: -40°C to +125°C, Voltage Range: 2.4V to 3.6V

Speed (ns)	Order Part No.	Package
10	IS64WV5128FBLL-10BA3	36-ball mini BGA (6mm x 8mm)
10	IS64WV5128FBLL-10BLA3	36-ball mini BGA (6mm x 8mm), Lead-free
10	IS64WV5128FBLL-10KLA3	400-mil Plastic SOJ, Lead-free
10	IS64WV5128FBLL-10CTLA3	TSOP (Type II) , Lead-free

PACKAGE INFORMATION

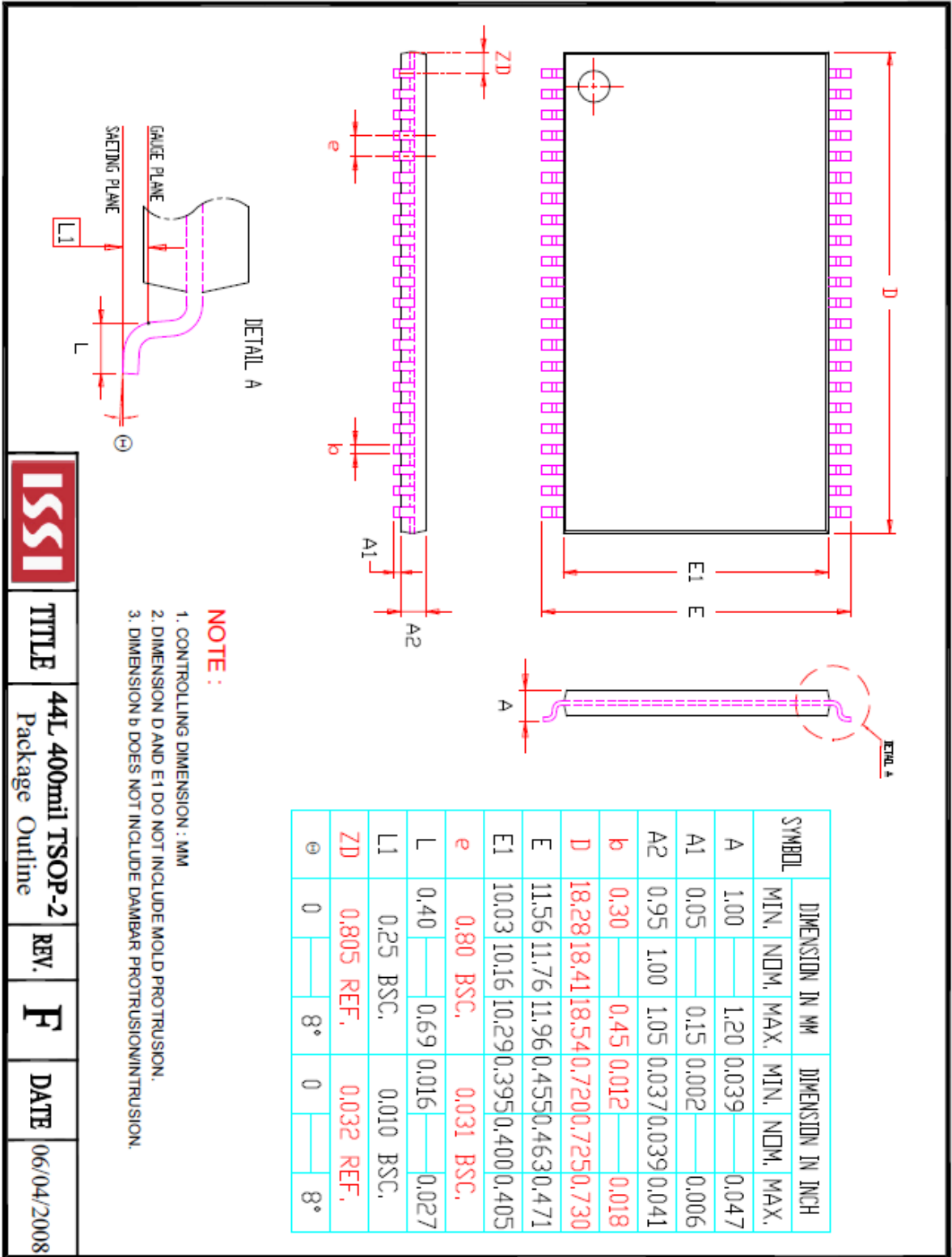

TITLE

44L 400mil TSOP-2
Package Outline

REV.

F

DATE

06/04/2008

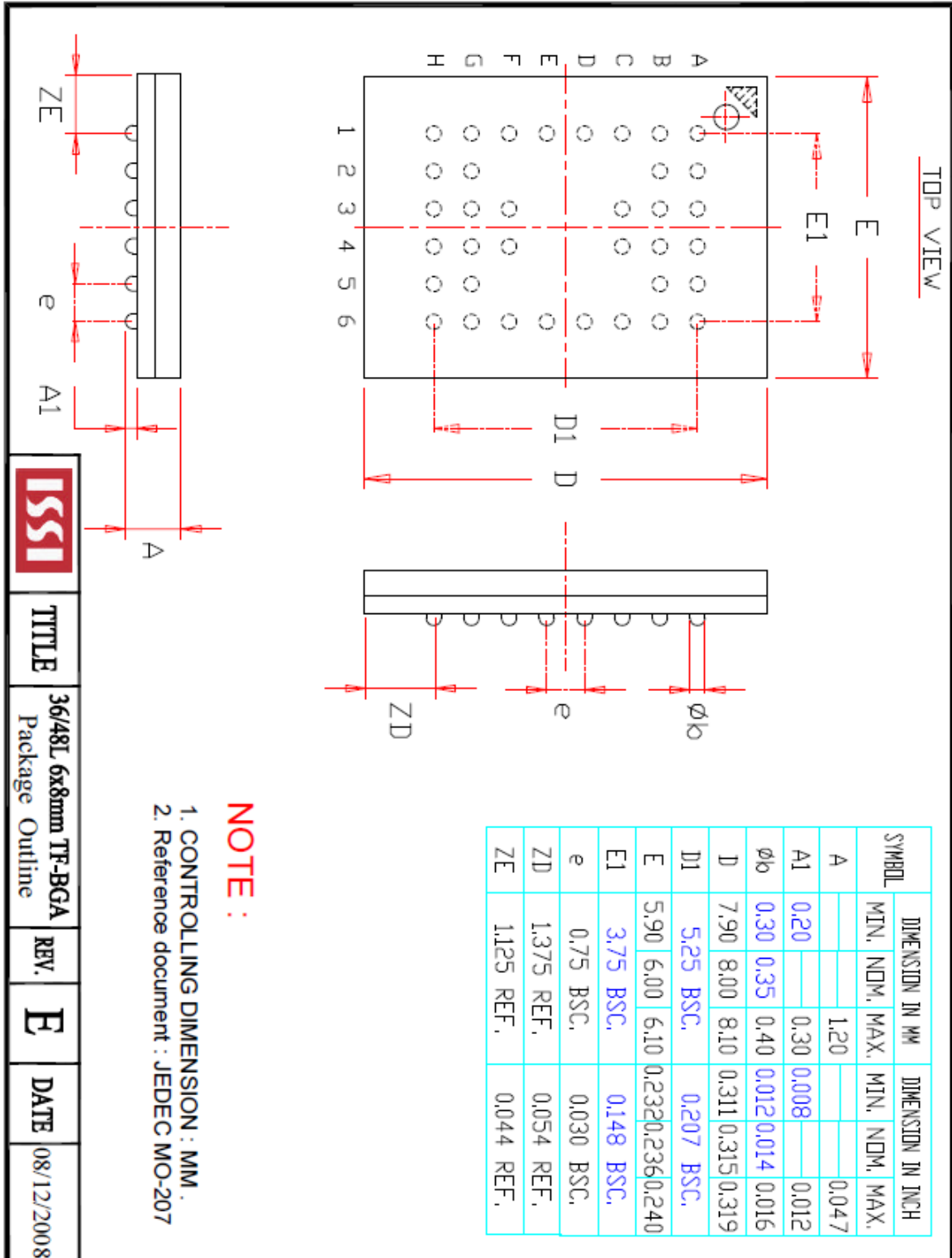

TITLE

36/48L 6x8mm TF-BGA
Package Outline

REV.

E

DATE

08/12/2008

IS61/64WV5128FALL
IS61/64WV5128FBLL

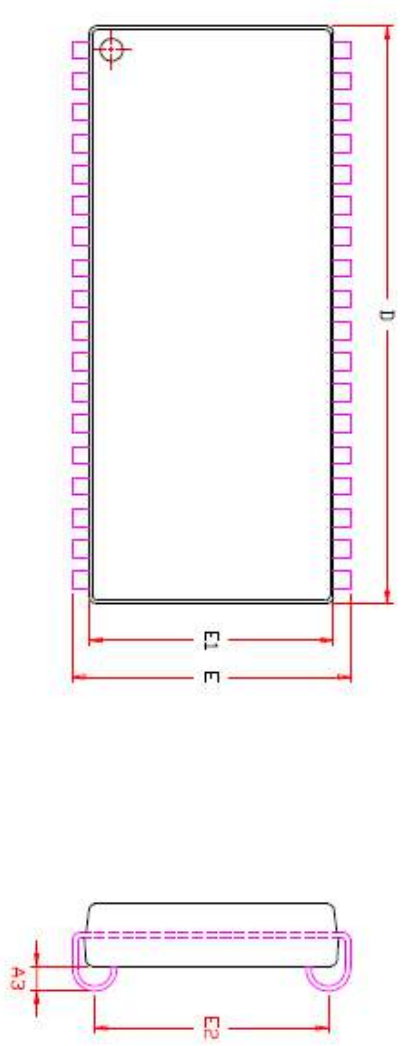

- NOTE :**
1. Controlling dimension : mm
 2. Dimension D and E1 do not include mold protrusion .
 3. Dimension b2 does not include dambar protrusion/intrusion.
 4. Formed leads shall be planar with respect to one another within 0.1mm at the seating plane after final test.
 5. Reference document : JEDEC SPEC MS-027.

SYMBOL	DIMENSION IN MM		DIMENSION IN INCH	
	MIN.	MAX.	MIN.	MAX.
A	3.25	3.76	0.128	0.148
A1	2.08		0.082	
A3	0.635		0.025	
b	0.38	0.51	0.015	0.020
b2	0.66	0.71	0.026	0.028
D	23.36	23.49	0.921	0.929
E	11.05	11.18	0.435	0.445
E1	10.03	10.16	0.395	0.405
E2	9.40		0.370	
e	1.27		0.050	
ZD	0.95		0.037	

	TITLE	36L 400mil SOJ Package Outline	REV.	F	DATE	12/20/2007
--	-------	--------------------------------	------	---	------	------------