

# Features

# Switching Regulator

- Non-isolated
- Synchronous rectification design
- Adjustable output voltage
- 2, 3, 4 & 5AMP adjustable positive step down integrated switching regulator
- Over load protection
- Continuous short circuit protection
- Efficiency up to 96%



## R-5xxxPA\_DA

**2,3,4,5 Amp  
SIP12  
Vertical &  
Horizontal  
Single Output**



### Description

The R-5xxxA series is a high performance 1.2V to 5.5V, 2Amp to 5Amp, 12-Pin SIP (single in-line package) integrated switching regulator (ISR). The synchronous - rectified design yields excellent efficiencies up to 96%. Short circuit protection reduces the short circuit input current to under 50mA. Autosense function compensates for any losses in long circuit loops.

### Selection Guide

Part Number	Input Voltage Range [VDC]	Output Voltage [VDC]	Vout Adjust Range <sup>(1)</sup> [VDC]	Output Current [A]	Efficiency			Max. Capacitive Load <sup>(2)</sup> [µF]
					@ min Vin [%]	@ 12V [%]	@ max. Vin [%]	
R-521.2xA	4.5 - 18	1.2	1.0 - 3.0	2	83	79	75	300/6800
R-521.8xA	4.5 - 18	1.8	1.1 - 4.5	2	88	85	82	300/6800
R-522.5xA	4.5 - 18	2.5	1.6 - 5.5	2	91	88	86	300/6800
R-523.3xA	4.5 - 18	3.3	1.6 - 5.5	2	92	90	89	300/6800
R-525.0xA	6.5 - 18	5.0	3.0 - 5.5	2	95	93	92	300/6800
R-531.2xA	4.5 - 18	1.2	1.0 - 3.0	3	85	84	82	300/6800
R-531.8xA	4.5 - 18	1.8	1.1 - 4.5	3	89	88	86	300/6800
R-532.5xA	4.5 - 18	2.5	1.6 - 5.5	3	92	91	89	300/6800
R-533.3xA	4.5 - 18	3.3	1.6 - 5.5	3	94	93	92	300/6800
R-535.0xA	6.5 - 18	5.0	3.0 - 5.5	3	96	95	94	300/6800
R-541.2xA	4.5 - 18	1.2	1.0 - 3.0	4	82	81	79	300/6800
R-541.8xA	4.5 - 18	1.8	1.1 - 4.5	4	87	86	85	300/6800
R-542.5xA	4.5 - 18	2.5	1.6 - 5.5	4	91	89	88	300/6800
R-543.3xA	4.5 - 18	3.3	1.6 - 5.5	4	93	92	91	300/6800
R-545.0xA	6.5 - 18	5.0	3.0 - 5.5	4	95	94	93	300/6800
R-551.2xA	4.4 - 18	1.2	1.0 - 3.0	5	81	80	78	300/6800
R-551.8xA	4.5 - 18	1.8	1.1 - 4.5	5	86	85	84	300/6800
R-552.5xA	4.5 - 18	2.5	1.6 - 5.5	5	90	89	88	300/6800
R-553.3xA	4.5 - 18	3.3	1.6 - 5.5	5	92	91	90	300/6800
R-555.0xA	7.0 - 18	5.0	3.0 - 5.5	5	94	93	92	300/6800

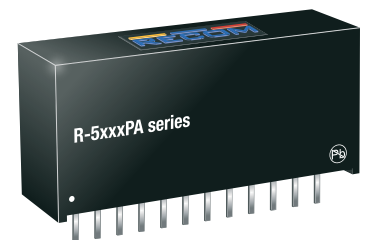

IEC/EN60950-1 certified

### Notes:

Note1: Vin-Vout ≥ 1.5V~4.0V depending on Vout if adjust function is used

Note2: please refer to basic characteristics

### Model Numbering

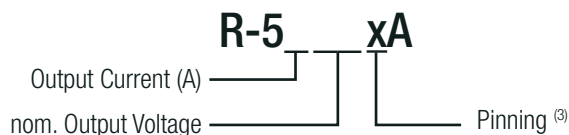

### Notes:

Note3: x can be „P“= vertical through hole

x can be „D“ = bent for horizontal through hole mounting

### Ordering Examples:

R-553.3PA Iout= 5A      nom. Vout= 3.3VDC      P= vertical through hole  
 R-522.5DA Iout= 2A      nom. Vout= 2.5VDC      D= bent for horizontal through hole mounting

**Specifications** (refer to standard application circuit, Ta= 25°C)

**BASIC CHARACTERISTICS**

Parameter	Condition	Min.	Typ.	Max.
Quiescent Current	min. Vin to max.			20mA
Internal Power Dissipation	ta<60°C			1.4W
Output Current Limit	R-52xx		2.5A	3.0A
	R-53xx		3.75A	4.25A
	R-54xx		5.0A	5.5A
	R-55xx		6.0A	6.5A
Minimum Load		10%		
ON/OFF CTRL (4)	DC-DC ON DC-DC OFF		Open or high, 4.5V min. / 18V max. Low (Power OFF) 0.8V max.	
Input Current of CTRL Pin	DC-DC OFF			100µA
Internal Operating Frequency		270kHz	300kHz	330kHz
Output Ripple and Noise	R-52xx		40mVp-p	70mVp-p
	R-53xx & R-54xx & R-55xx		80mVp-p	120mVp-p
Maximum Capacitive Load	normal start-up time, no external diodes			300µF
	<1 second start-up time + diode protection circuit			6800µF

**Notes:**

Note4: ON/OFF pin driven by TTL (logic gate), open-collector bipolar transistor or open-drain MOSFET

**How to calculate the max. output current**

The internal power dissipation (P<sub>D</sub>) follows the equation:

$$P_D = I_{out} \times V_{out} \times (1 - \text{Eff}_{\max V_{in}})$$

$$I_{out} = \frac{P_D}{V_{out} \times (1 - \text{Eff}_{\max V_{in}})}$$

**Example: R-545.0P**

**Calculation 1:**

V<sub>in</sub> = 18V

V<sub>out</sub> = 5V

Eff<sub>max V<sub>in</sub></sub> = 93%

P<sub>D</sub> = 1.4W

T<sub>Ambient</sub> = 60°C

$$I_{out} = \frac{1.4W}{5V \times (1 - 0.93)} = 4.0A$$

**Calculation 2:**

V<sub>in</sub> = 18V

V<sub>out</sub> = 5V

Eff<sub>max V<sub>in</sub></sub> = 93%

P<sub>D</sub> = 1W

T<sub>Ambient</sub> = 85°C

$$I_{out} = \frac{1W}{5V \times (1 - 0.93)} = 2.857A$$

**Calculation 3:**

V<sub>in</sub> = 12V

Eff<sub>max V<sub>in</sub></sub> = 94%

P<sub>D</sub> = 1.0W

T<sub>Ambient</sub> = 85°C

$$I_{out} = \frac{1W}{5V \times (1 - 0.94)} = 3.33A$$

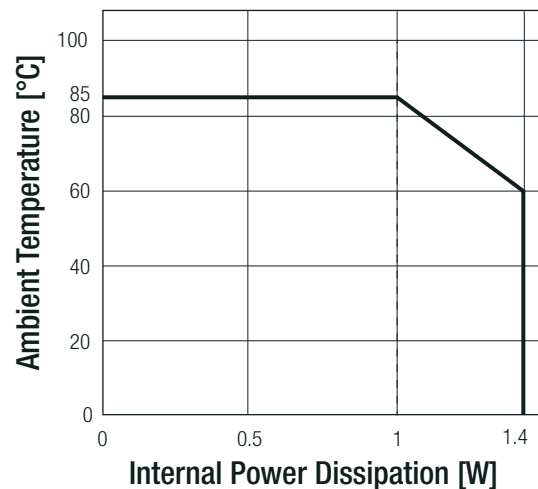

continued on next page

**Specifications** (refer to standard application circuit, Ta= 25°C)

**Efficiency vs. Load**

R-53xx / R-54xx / R-55xx  
min. Vin

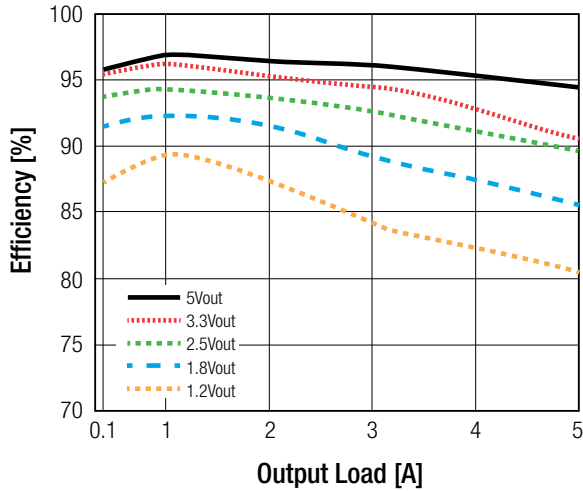

R-52xx  
min. Vin

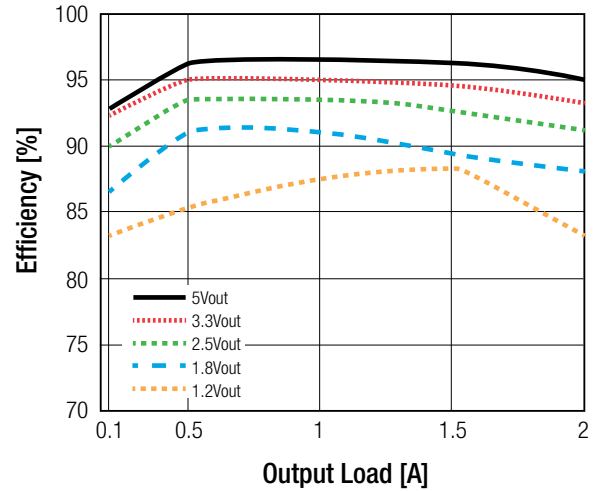

R-53xx / R-54xx / R-55xx  
Vin=18V

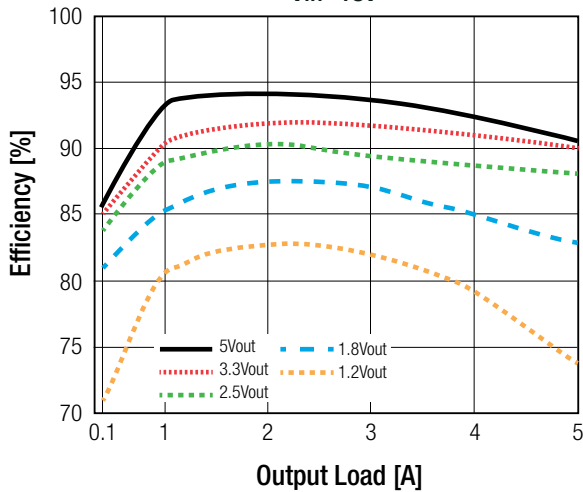

R-52xx  
Vin=18V

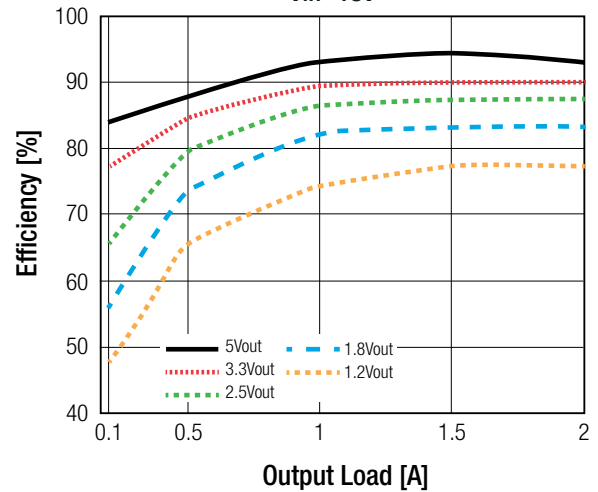

**Trim Tables or Calculation**

2ADC	R-521.2PA/DA	R-521.8PA/DA	R-522.5PA/DA	R-523.3PA/DA	R-525.0PA/DA
3ADC	R-531.2PA/DA	R-531.8PA/DA	R-532.5PA/DA	R-533.3PA/DA	R-535.0PA/DA
4ADC	R-541.2PA/DA	R-541.8PA/DA	R-542.5PA/DA	R-543.3PA/DA	R-545.0PA/DA
5ADC	R-551.2PA/DA	R-551.8PA/DA	R-552.5PA/DA	R-553.3PA/DA	R-555.0PA/DA

Vout nom.	1.2VDC		1.8VDC		2.5VDC		3.3VDC		5.0VDC	
Vout adj.	R <sub>down</sub>	R <sub>up</sub>	R <sub>down</sub>	R <sub>up</sub>	R <sub>down</sub>	R <sub>up</sub>	R <sub>down</sub>	R <sub>up</sub>	R <sub>down</sub>	R <sub>up</sub>
0.8										
0.9	740Ω									
1.0	3.9kΩ									
1.1	13kΩ		1.05kΩ							
1.2			2.1kΩ		270Ω					

continued on next page

**Specifications** (refer to standard application circuit, Ta= 25°C)

**Trim Tables or Calculation**

2ADC	R-521.2PA/DA	R-521.8PA/DA	R-522.5PA/DA	R-523.3PA/DA	R-525.0PA/DA
3ADC	R-531.2PA/DA	R-531.8PA/DA	R-532.5PA/DA	R-533.3PA/DA	R-535.0PA/DA
4ADC	R-541.2PA/DA	R-541.8PA/DA	R-542.5PA/DA	R-543.3PA/DA	R-545.0PA/DA
5ADC	R-551.2PA/DA	R-551.8PA/DA	R-552.5PA/DA	R-553.3PA/DA	R-555.0PA/DA

Vout nom.	1.2VDC		1.8VDC		2.5VDC		3.3VDC		5.0VDC	
Vout adj.	R <sub>down</sub>	R <sub>up</sub>	R <sub>down</sub>	R <sub>up</sub>	R <sub>down</sub>	R <sub>up</sub>	R <sub>down</sub>	R <sub>up</sub>	R <sub>down</sub>	R <sub>up</sub>
1.3		37kΩ	3.7kΩ		750Ω					
1.5		11.5kΩ	10kΩ		2.1KΩ		390Ω			
1.6		8.2kΩ	18kΩ		3.0KΩ		750Ω			
1.7		6.5kΩ	41kΩ		4.1KΩ		1.2kΩ			
1.8		5.2kΩ			5.6KΩ		1.7kΩ			
1.9		4.3kΩ		36kΩ	7.5KΩ		2.2kΩ			
2.0		3.6kΩ		1.8kΩ	10.5KΩ		2.8kΩ			
2.4		2.1kΩ		5.2kΩ	82KΩ		6.8kΩ			
2.5		1.8kΩ		4.3kΩ			8.5kΩ			
2.6		1.65kΩ		3.6kΩ		33kΩ	10.5kΩ			
3.0		1.05kΩ		2.1kΩ		6.2kΩ	33kΩ		470Ω	
3.2				1.65kΩ		4.1kΩ	110kΩ		1.6kΩ	
3.3				1.5kΩ		3.4kΩ			2.2kΩ	
3.4				1.35kΩ		2.9kΩ		36kΩ	3.0kΩ	
3.6				1.07kΩ		2.2kΩ		11kΩ	4.7kΩ	
3.9				780Ω		1.4kΩ		4.7kΩ	8.5kΩ	
4.5				390Ω		650Ω		1.6Ω	30kΩ	
4.9						350Ω		820Ω	220kΩ	
5.0						290Ω		680Ω		
5.1						220Ω		560Ω		28kΩ
5.5						39Ω		190Ω		2.6kΩ

**REGULATIONS**

Parameter	Condition		Value
Output Accuracy			±1.0% typ. / ±2.0% max.
Line Regulation	low line to high line, full load	R-52xx R-53xx & R-54xx & R-55xx	±0.25% typ. / ±0.5% max. ±0.5% typ. / ±1.0% max.
Load Regulation <sup>(5)</sup>	10% to 100%, full load	R-52xx R-53xx & R-54xx & R-55xx	±0.5% typ. / ±1.0% max. ±1.0% typ. / ±2.0% max.
Transient Response <sup>(6)</sup>	50% load step change Vout Over / Undershoot		100µs typ. / 200µs max. 100mV max.

**Notes:**

Note5: Operation below 10% load will not harm the converter, but specifications may not be met

Note6: Requires a 100µF electronic or tantalum output capacitor for proper operation in all applications (the capacitor has to be placed as close as possible to the output pins):  
100µF for R-52xxx, R-53xx and R-54xx, 220µF for R-55xx

continued on next page

**Specifications** (refer to standard application circuit, Ta= 25°C)

**Line Regulation**

R-53xx / R-54xx

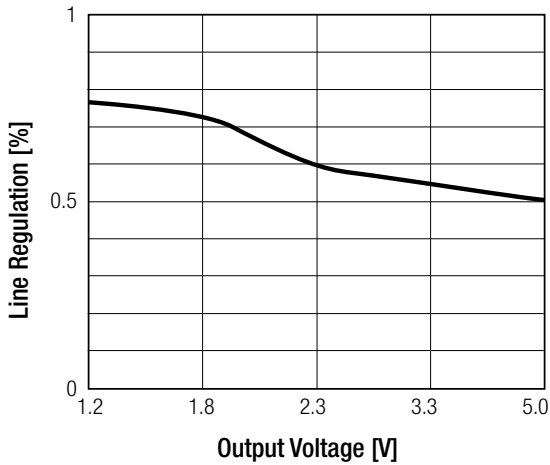

R-52xx / R-55xx

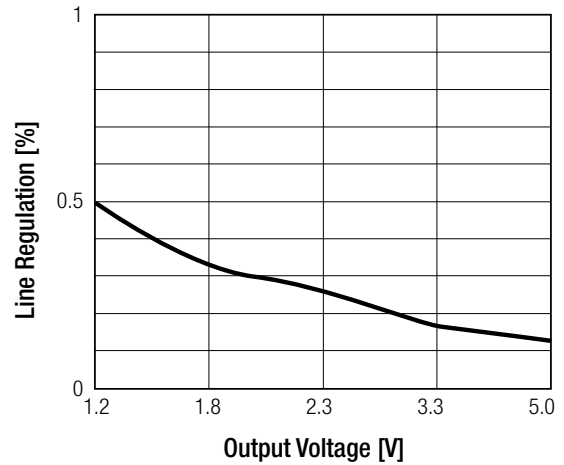

**Load Regulation**

R-53xx / R-54xx

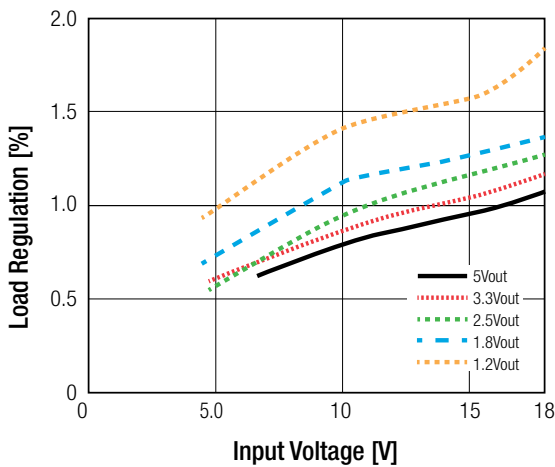

R-52xx / R-55xx

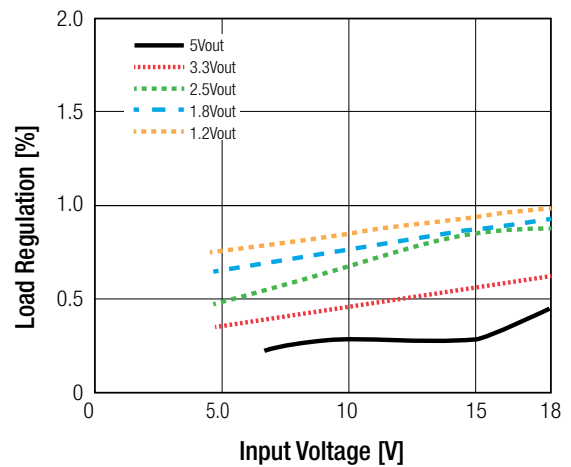

**PROTECTIONS**

Parameter	Condition	Value
Short Circuit Protection (SCP)		continuous, automatic recovery
Short Circuit Input Current		50mA max.

continued on next page

**Specifications** (refer to standard application circuit, Ta= 25°C)

**Optional Diode Protection Circuit**

Add a blocking diode to Vout if current can flow backwards into the output, as this can damage the converter when it is powered down. Protection diodes are required for high capacitive loads.

The diode can either be fitted across the device, if the source is low impedance or fitted in series with the output (recommended).

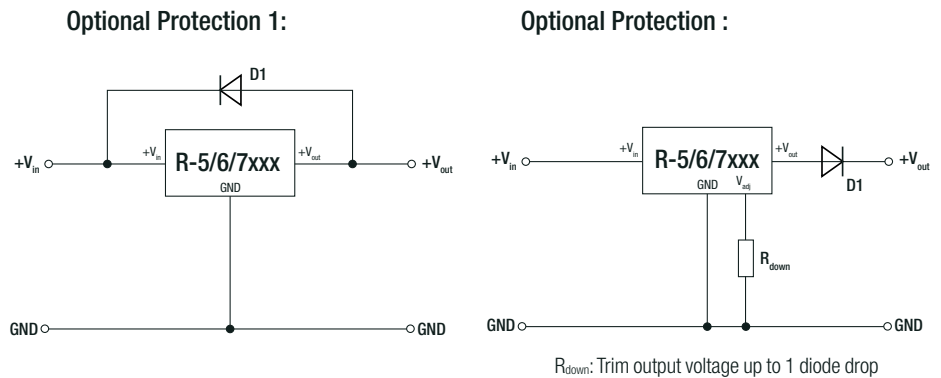

ENVIRONMENTAL			
Parameter	Condition		Value
Operating Temperature Range	without derating @ natural convection 0.1m/s		-40°C to +85°C
Maximum Case Temperature			+110°C
Thermal Impedance	@ natural convection 0.1m/s		25°C/W
Operating Humidity	non-condensing		95% RH max.
Operating Altitude			2000m
Pollution Degree			PD2
MTBF	according to MIL-HDBK 217F, G.B.	+25°C	749 x 10 <sup>3</sup> hours
		+85°C	150 x 10 <sup>3</sup> hours

SAFETY AND CERTIFICATIONS		
Certificate Type (Safety)	Report / File Number	Standard
Information Technology Equipment, General Requirements for Safety	1605077-12	IEC60950-1:2005, 2nd Edition + AM2:2013 EN60950-1:2006 + AM2:2013
EAC	RU-AT.49.09571	TP TC 004/2011
RoHS 2+		RoHS-2011/65/EU + AM-2015/863

DIMENSION AND PHYSICAL CHARACTERISTICS		
Parameter	Type	Value
Material	case potting	non-conductive black plastic, (UL94 V-0) epoxy, (UL94 V-0)
Dimension (LxWxH)		32.2 x 9.1 x 15.0mm
Weight		9g typ.

continued on next page

**Specifications** (refer to standard application circuit, Ta= 25°C)

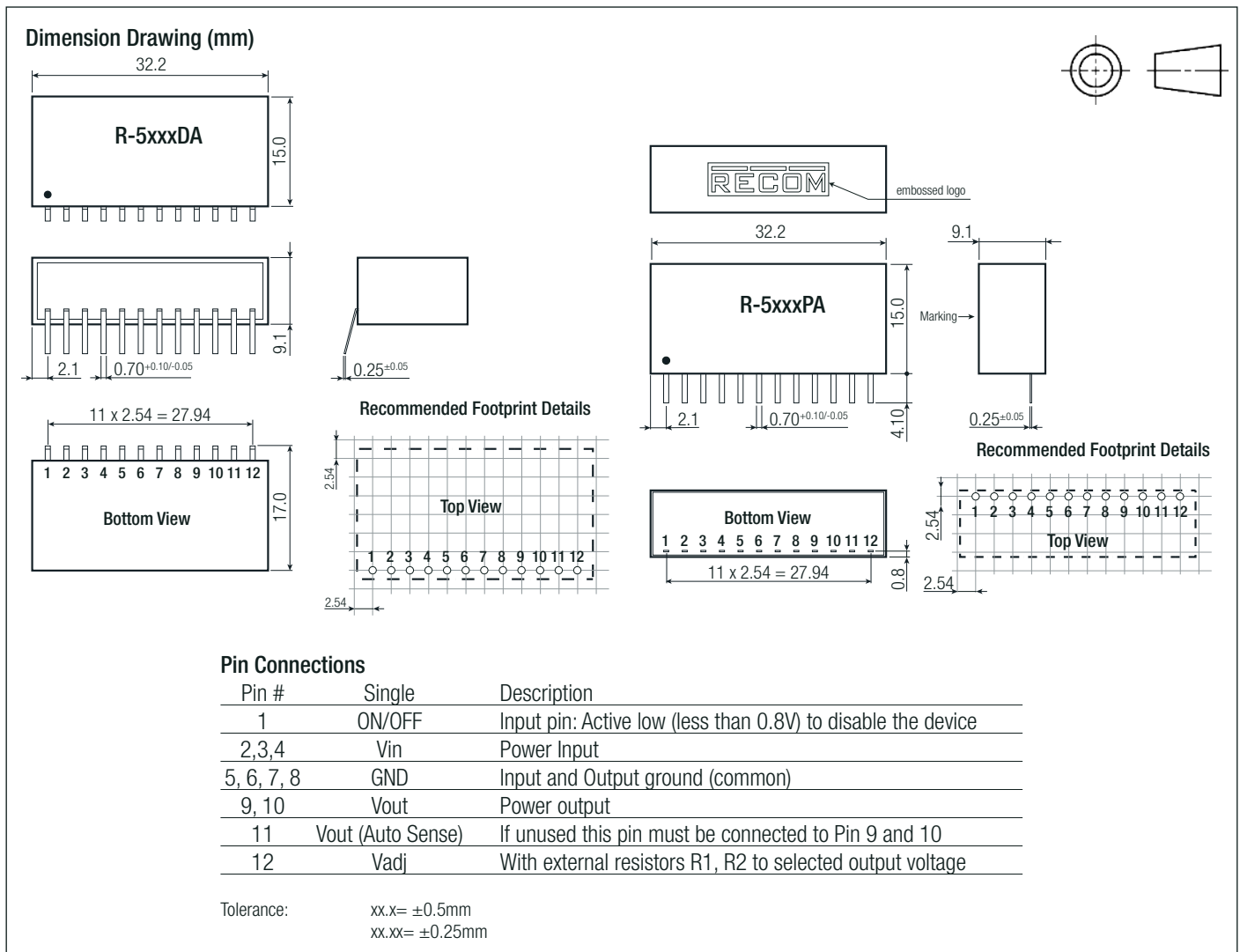

### INSTALLATION AND APPLICATION

#### Standard Application Circuit

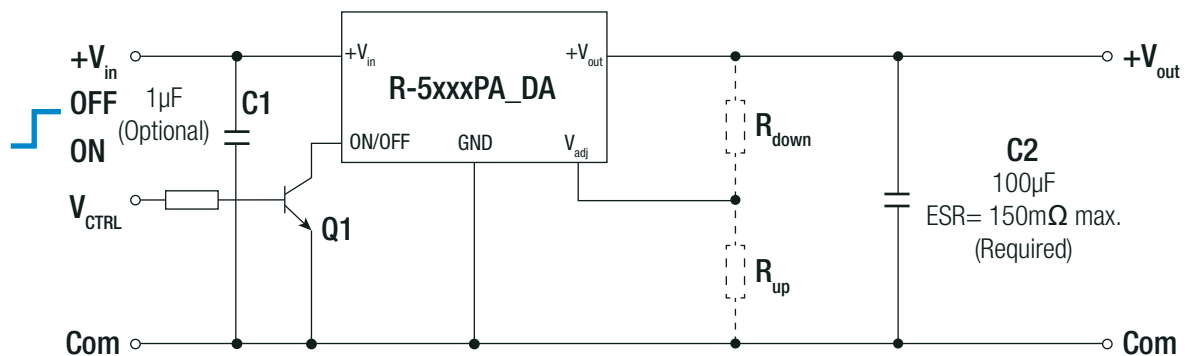

Add blocking diode to V<sub>out</sub> if current can flow backwards into the output, as this can damage the converter.  
(Please refer to "Optional Diode Protection Circuit" on page I-6)

continued on next page

**Specifications** (refer to standard application circuit, Ta= 25°C)

**Parallel Application Circuit**

The R-52xx, R-53xx, R-54xx series can be used in parallel to upgrade the output current capacity for the same output voltage. For example, the R-543.3PA can parallel up with another R-554.3PA to give up to 8 amps or with the R-533.3PA or R-23-3PA types to give output currents of up to 7 amps or 6 amps. The R-55xx series cannot be paralleled.

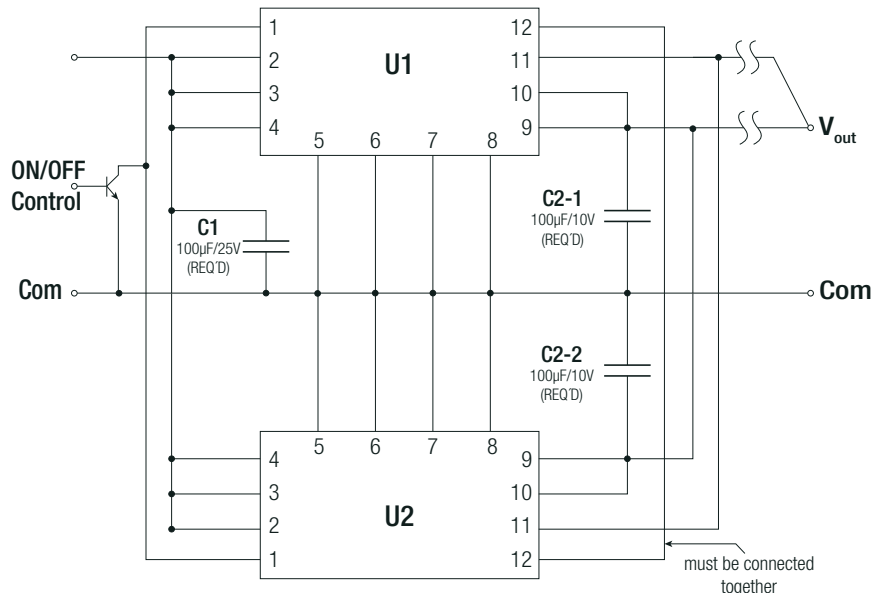

**Component side**



Keep 2mm to 5mm distance between both converters

**Solder side**

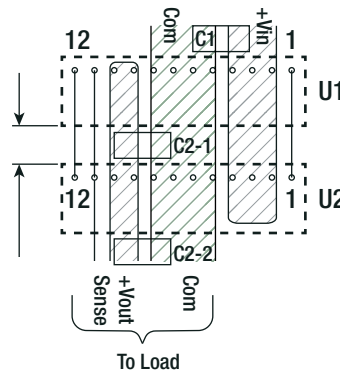

**PACKAGING INFORMATION**

Parameter	Type	Value
Packaging Dimensions (LxWxH)	R-5xxxDA	520.0 x 20.0 x 19.0mm
	R-5xxxPA	530.0 x 23.0 x 19.0mm
Packaging Quantity	tube	15pcs
Storage Temperature Range		-40°C to +125°C

The product information and specifications may be subject to changes even without prior written notice. The product has been designed for various applications; its suitability lies in the responsibility of each customer. The products are not authorized for use in safety-critical applications without RECOM's explicit written consent. A safety-critical application is an application where a failure may reasonably be expected to endanger or cause loss of life, inflict bodily harm or damage property. The applicant shall indemnify and hold harmless RECOM, its affiliated companies and its representatives against any damage claims in connection with the unauthorized use of RECOM products in such safety-critical applications.