

THIS DRAWING IS UNPUBLISHED. RELEASED FOR PUBLICATION
 © COPYRIGHT - By - ALL RIGHTS RESERVED.

LOC	DIST	REVISIONS			
P	LTR	DESCRIPTION	DATE	DWN	APVD
AD	00				
	R3	REVISED PER ECO-12-006399	10JUL12	KH	AS

- 1 MATERIAL : BRASS
- 2 FINISH : .000030 GOLD OVER .000050 NICKEL UNDERPLATE.
- 3 FINISH : .000050 GOLD OVER .000050 -.000100 NICKEL UNDERPLATE.
- 4 FINISH : .000050 -.000100 NICKEL PLATE ALL OVER.

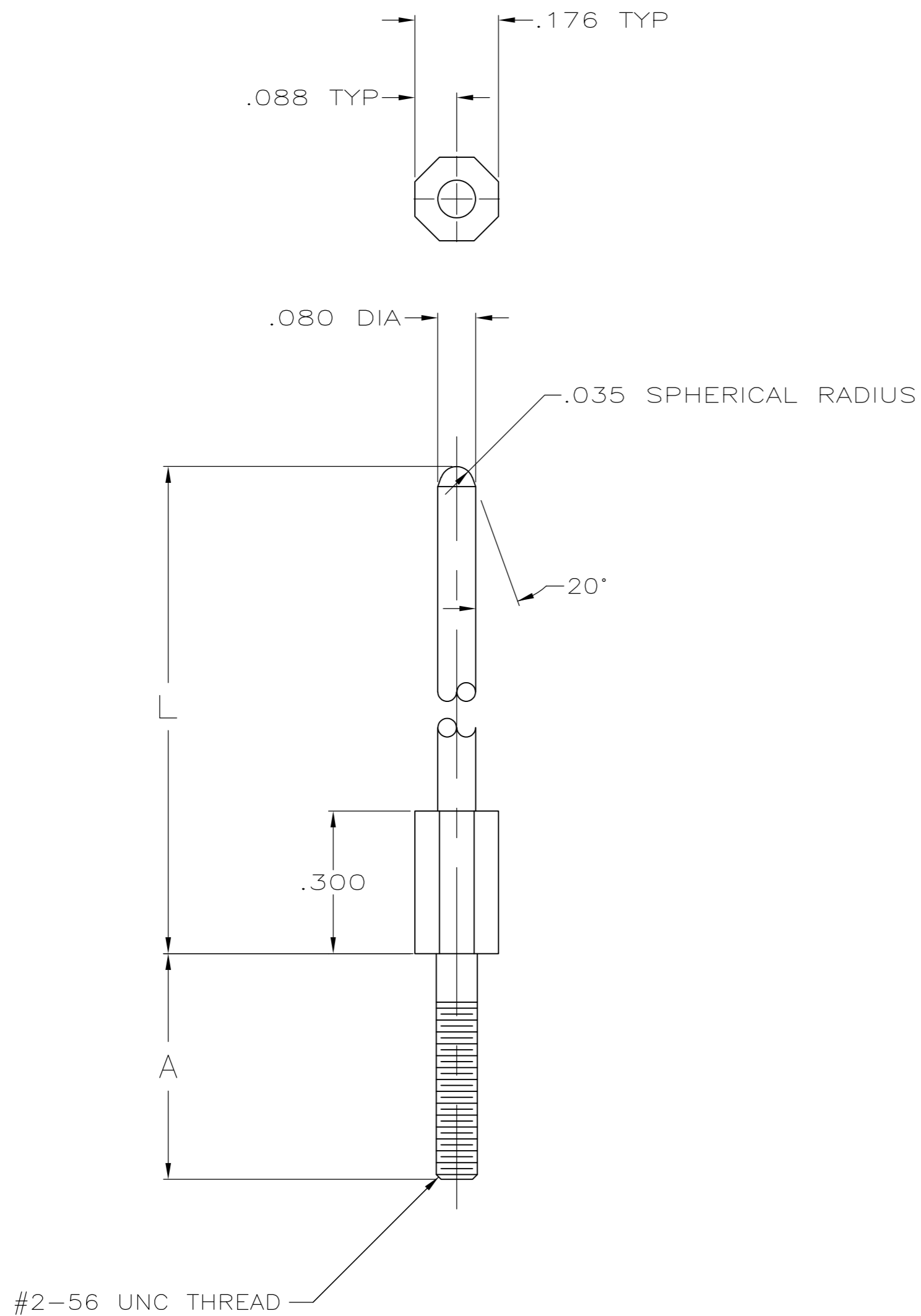

OBSOLETE	1.025	.450	PLAIN	2-533082-0
OBSOLETE	.750	.475	2	1-533082-9
OBSOLETE	.820	.560	PLAIN	1-533082-8
OBSOLETE	.750	.475	PLAIN	1-533082-7
OBSOLETE	1.195	.690	2	1-533082-6
OBSOLETE	1.195	.690	PLAIN	1-533082-5
OBSOLETE	.850	.560	2	1-533082-4
OBSOLETE	.850	.560	PLAIN	1-533082-3
OBSOLETE	1.195	.475	4	1-533082-2
	1.025	.560	2	1-533082-1
	1.025	.560	PLAIN	1-533082-0
	1.025	.475	2	533082-9
	1.025	.475	PLAIN	533082-8
	1.195	.475	PLAIN	533082-7
	1.195	.475	2	533082-6
OBSOLETE	1.025	.375	3	533082-5
	1.195	.375	2	533082-4
	1.025	.375	2	533082-3
	1.195	.375	PLAIN	533082-2
	1.025	.375	PLAIN	533082-1
	L	A	FINISH	PART NUMBER

THIS DRAWING IS A CONTROLLED DOCUMENT.		DWN DAVID HOFFMAN 03/20/90		
DIMENSIONS: INCHES		CHK J.D.WEARY 02/07/92		
TOLERANCES UNLESS OTHERWISE SPECIFIED:		APVD -	NAME	
0 PLC ± -		PRODUCT SPEC	AMP-HDI SERIES 100 KEYING POWER PIN	
1 PLC ± -		APPLICATION SPEC	SIZE	CAGE CODE
2 PLC ± -			A2	00779
3 PLC ± .005		WEIGHT	DRAWING NO	RESTRICTED TO
4 PLC ± -			C=533082	-
ANGLES ± -		CUSTOMER DRAWING	SCALE	SHEET
FINISH			4:1	1 of 1
1			REV	R3
2 3 4				