

ENERGIZER 312 size - **Mercury Free**

**ZnAir**

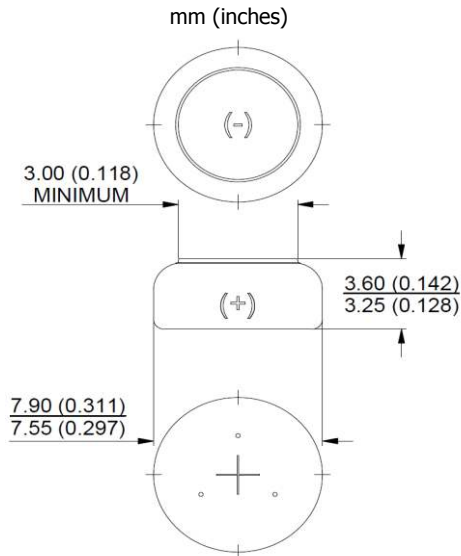

**Industry Standard Dimensions**



**Specifications**

<b>Chemical System:</b>	Zinc Air (Zn/O <sub>2</sub> )
<b>Tab Color:</b>	Brown
<b>Designation:</b>	ANSI-7002ZD, IEC-PR41
<b>Nominal Voltage:</b>	1.4 Volts
<b>Typical Capacity:</b>	181 mAh (to 1.05 volts) (IEC-STD at 10/2 mA at 21°C)
<b>Typical Weight:</b>	0.5 grams (0.02 oz.)
<b>Typical Volume:</b>	0.2 cubic centimeters (0.01 cubic inch)

**Typical Discharge Characteristics**

ANSI / IEC Industry Standards / Standard Test Protocol  
(10/2 mA .1S/1H59M 59.9S 12H at 21C)

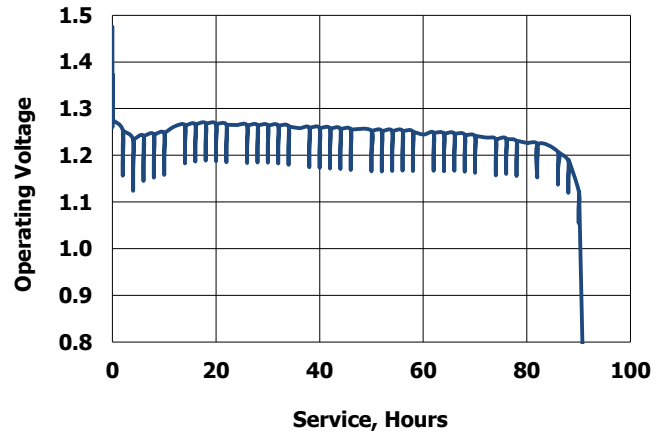

**Typical Discharge Characteristics**

ANSI/IEC Industry Standards / Wireless Streaming Protocol  
(5mA 15 min / 2mA 45 min 12 H cycle at 21C)

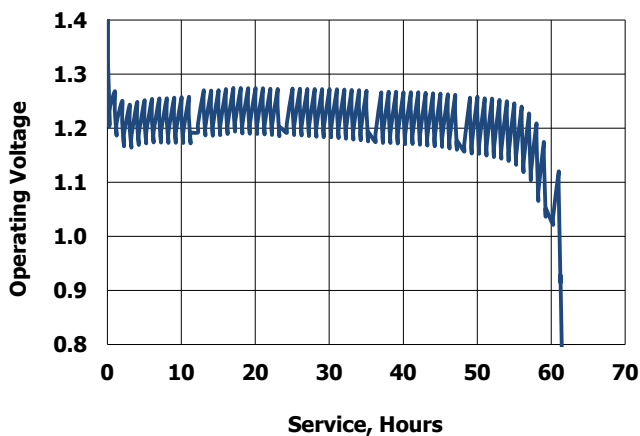

**Important Notice**

This datasheet contains typical information specific to products manufactured at the time of its publication.  
**Contents herein do not constitute a warranty and are for reference only.**