

LOC		Q1ST		REVISIONS				
AD	39	P	F	ZONE	LTR	DESCRIPTION	DATE	APPD
					O	RELEASED	3/93	SB
					A	REV PER 0010-1492-95	11-95	JH
					B	REV PER 0010-1175-95	12-30-96	JH

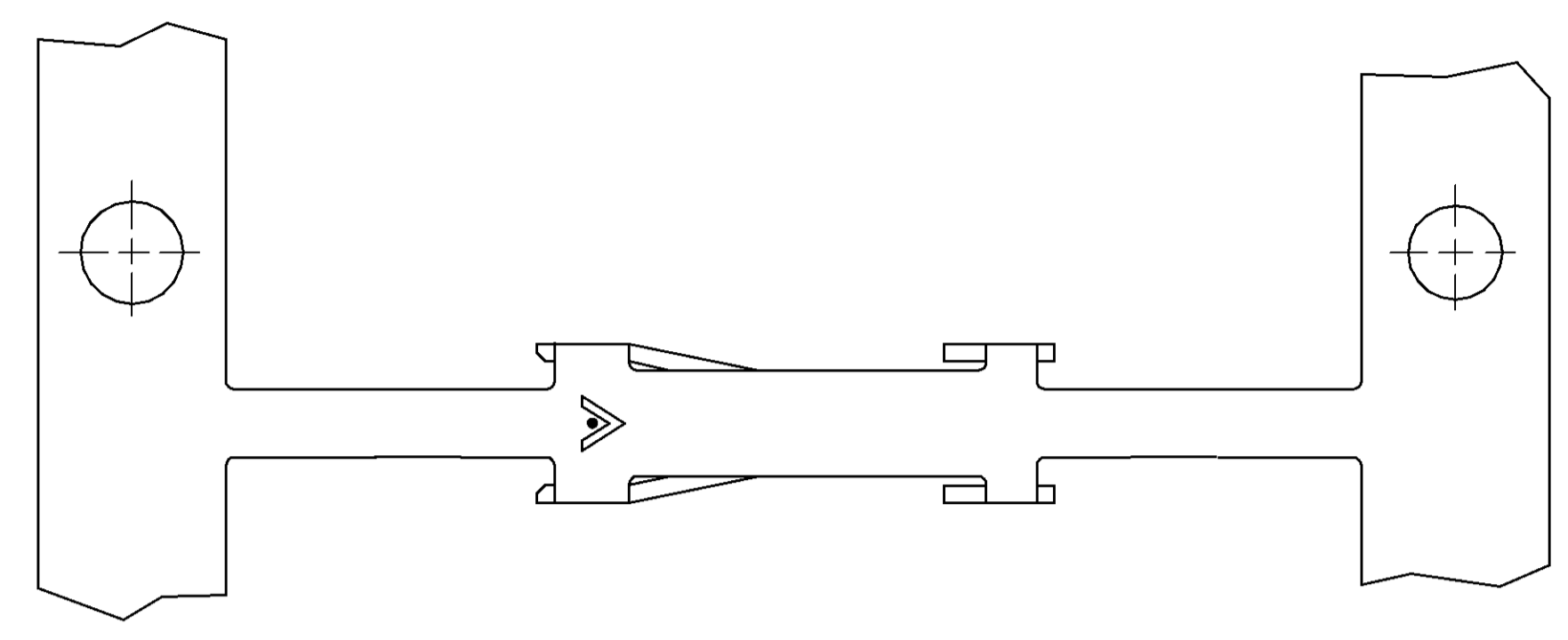

△ FINISH: PRE-TIN

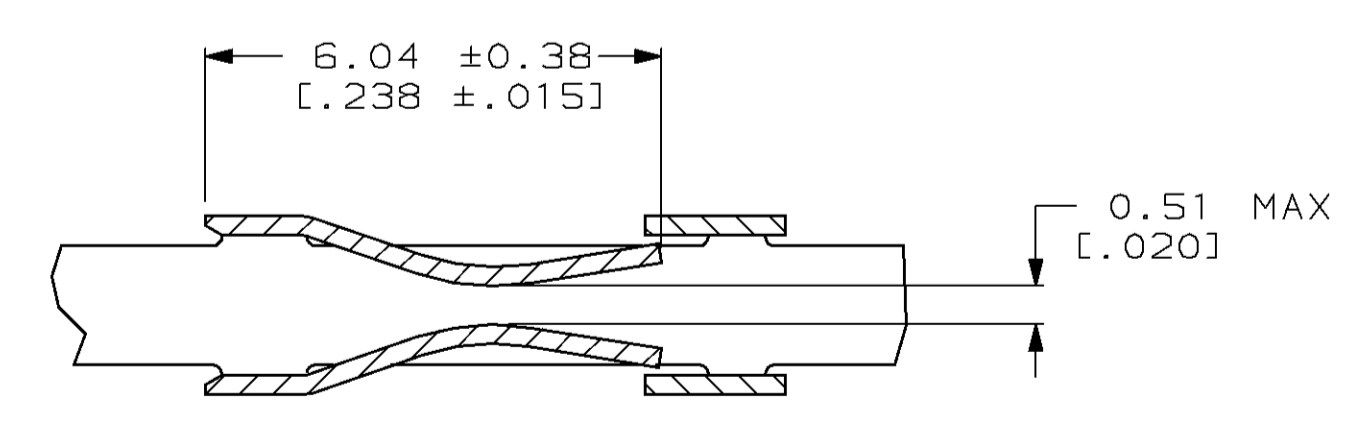
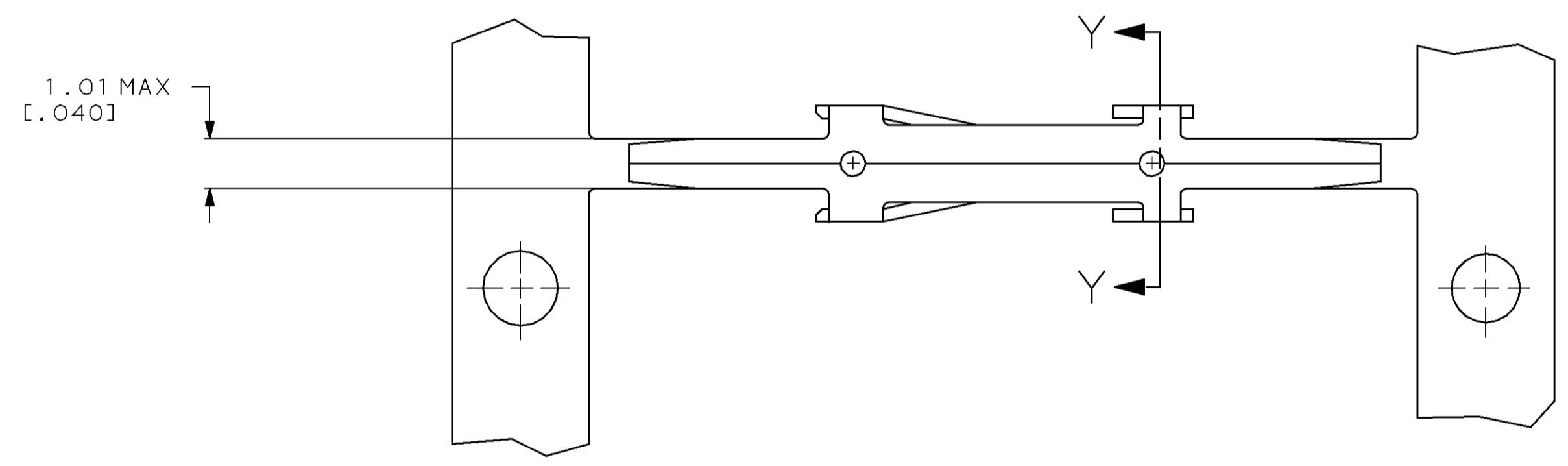
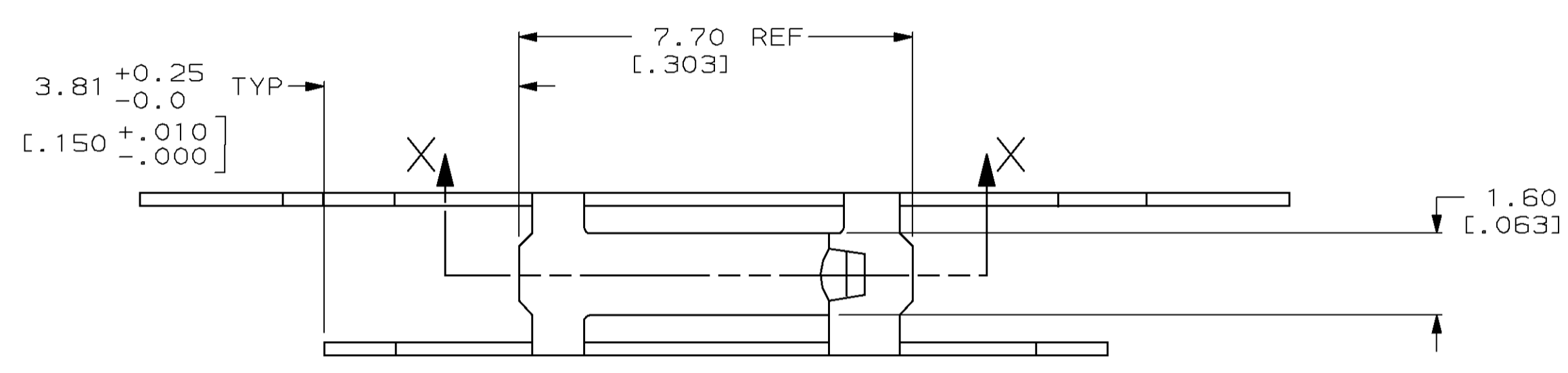

SECTION X-X

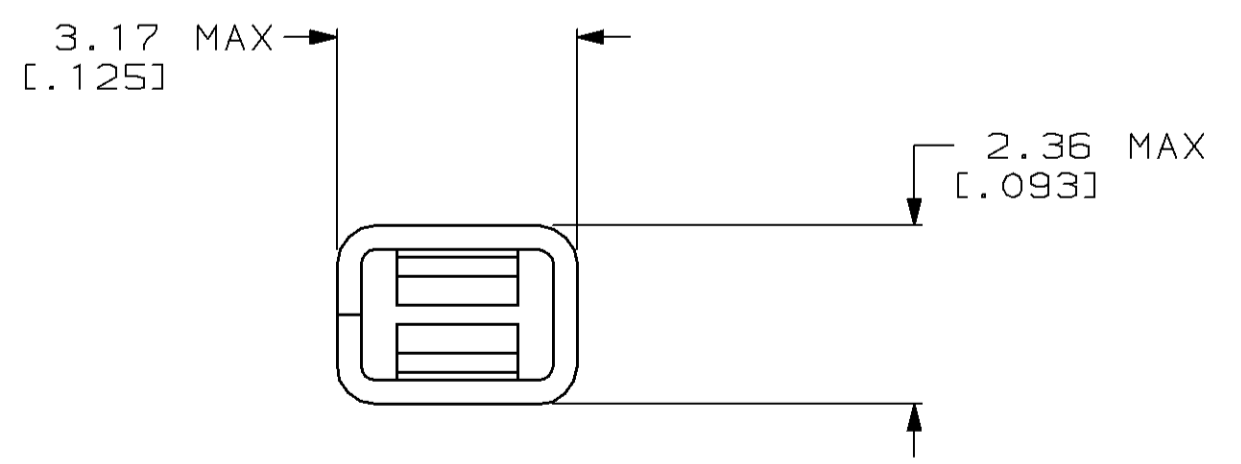

SECTION Y-Y

104885-1
 PART NUMBER
 PART NO

DO NOT SCALE PRINT. UNLESS SPECIFIED DIMENSIONS IN mm [INCHES] TOLERANCES ON + 2 PLC DEC ±0.13[.005] ANGLES ± -		DR 3/11/93 SAM BEAM		AMP Incorporated Harrisburg, PA 17105-3608	
MATERIAL PHOS BRONZE		CHK 3-16-93 S. SHUEY			
FINISH △		APPD 3-16-93 S. BEAM		NAME CONT, RCPT, TYPE C BRD MNT, HIGH PRESS MOD I	
APPLICATION SPEC 114-25004		APPD 3-17-93 D. DUPLER		PRODUCT SPEC 108-25025	
WEIGHT -		SIZE D	CAGE CODE 00779	DRAWING NO C-104885	SHEET 1 OF 1
SCALE 10:1		CUSTOMER DRAWING			

THIS DRAWING IS A CONTROLLED DOCUMENT FOR AMP INCORPORATED. IT IS SUBJECT TO CHANGE AND THE CONTROLLING ENGINEERING ORGANIZATION SHOULD BE CONTACTED FOR THE LATEST REVISION.