

FAN8702/FAN8702B/FAN8702MP

6 Channel DSC Motor Driver

Features

- Independent 6-Channel H-Bridge.
- Output Current up to 600mA (Each Channel)
- Constant Current Control on CH5 and CH6.
- Constant Voltage Control on CH1,2,3 and CH4.
- Built in Brake Function on CH3,4 and CH6.
- Built in Short Through Protection.
- Low Saturation Voltage.
- Low Voltage operation.
- Built in Reference Voltage.
- Built in Thermal Shut Down.

Description

The FAN8702 is designed for portable equipment such as DSC and mobile phone camera. It consists of 2 constant current and 4 constant voltage drive blocks suitable for shutter, auto-focus, iris and zoom motor drive.

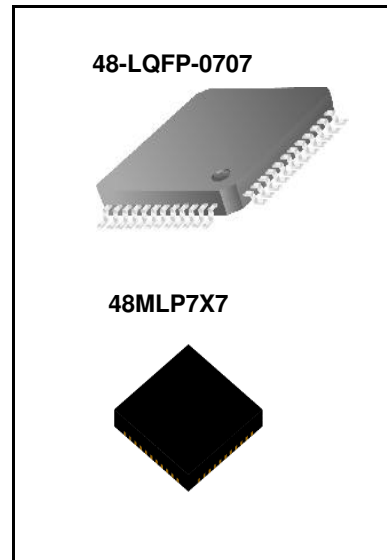

Typical Applications

- DSC
- Mobile Phone Camera

Ordering Information

Device	Package	Operating Temp.
FAN8702MP	48MLP 7X7	-20°C to +80°C
FAN8702MPX	48MLP 7X7	-20°C to +80°C
FAN8702	48-LQFP-0707	-20°C to +80°C
FAN8702B	48-LQFP-0707	-20°C to +80°C

Notes
X : Tape & Reel

Pin Assignments

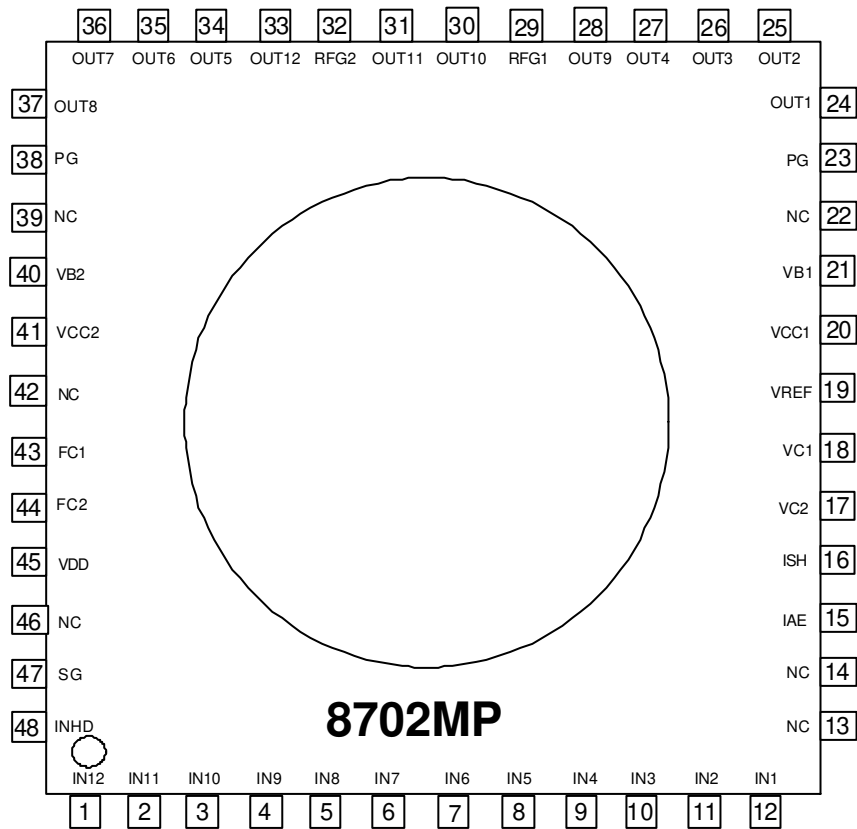
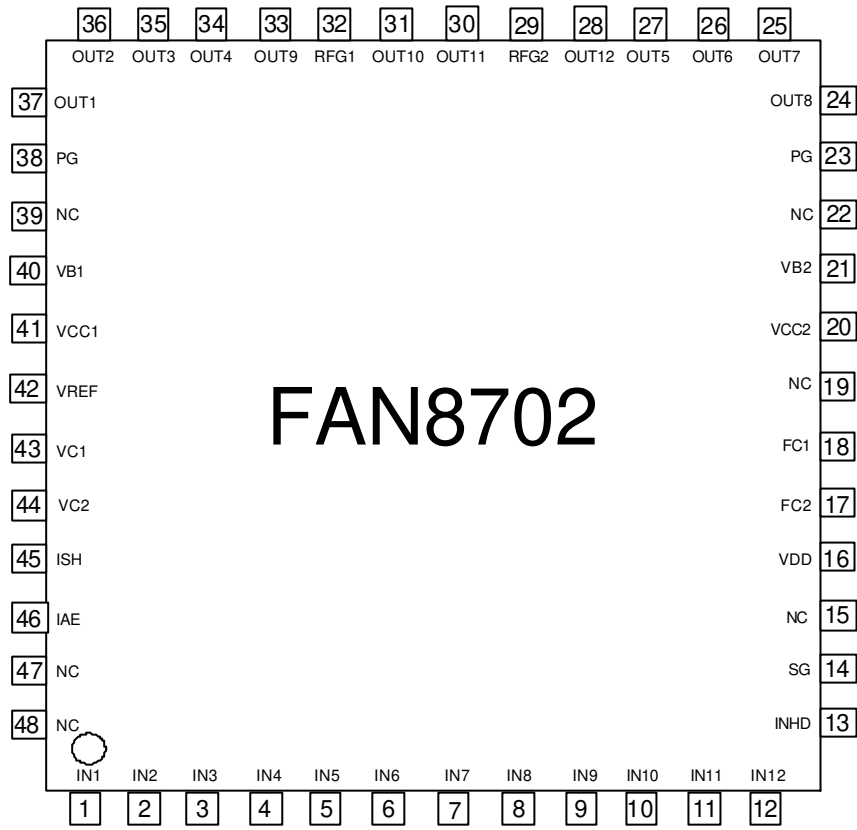

Pin Definitions

Pin Number		Pin Name	I/O	Pin Function Description	Remark
FAN8702/B	FAN8702MP				
1	12	IN 1	I	Logic Input 1	-
2	11	IN 2	I	Logic Input 2	-
3	10	IN 3	I	Logic Input 3	-
4	9	IN 4	I	Logic Input 4	-
5	8	IN 5	I	Logic Input 5	-
6	7	IN 6	I	Logic Input 6	-
7	6	IN 7	I	Logic Input 7	-
8	5	IN 8	I	Logic Input 8	-
9	4	IN 9	I	Logic Input 9	-
10	3	IN 10	I	Logic Input 10	-
11	2	IN 11	I	Logic Input 11	-
12	1	IN 12	I	Logic Input 12	-
13	48	INHD	I	Voltage Adjust for Vref	-
14	47	SG	P	Signal Ground	-
15	46	NC	-	Non Connection	-
16	45	VDD	P	Supply Voltage (Logic Voltage)	-
17	44	FC2	A	Compensation 2	-
18	43	FC1	A	Compensation 1	-
19	42	NC	-	Non Connection	-
20	41	VCC2	P	Supply Voltage (Current Drive2)	-
21	40	VB2	P	Supply Voltage (Voltage Drive2)	-
22	39	NC	-	Non Connection	-
23	38	PG	P	Power Ground	-
24	37	OUT8	A	Voltage Driver OUT8	-
25	36	OUT7	A	Voltage Driver OUT7	-
26	35	OUT6	A	Voltage Driver OUT6	-
27	34	OUT5	A	Voltage Driver OUT5	-
28	33	OUT12	A	Current Driver OUT12	-
29	32	RFG2	A	Current Sensing2	-
30	31	OUT11	A	Current Driver OUT11	-
31	30	OUT10	A	Current Driver OUT10	-
32	29	RFG1	A	Current Sensing1	-
33	28	OUT9	A	Current Driver OUT9	-
34	27	OUT4	A	Voltage Driver OUT4	-
35	26	OUT3	A	Voltage Driver OUT3	-
36	25	OUT2	A	Voltage Driver OUT2	-
37	24	OUT1	A	Voltage Driver OUT1	-
38	23	PG	P	Power Ground	-
39	22	NC	-	Non Connection	-
40	21	VB1	P	Supply Voltage (Voltage Drive1)	-

Pin Definitions (Continued)

Pin Number		Pin Name	I/O	Pin Function Description	Remark
Pin Number	Pin Number				
41	20	VCC1	P	Supply Voltage (Current Drive1)	-
42	19	VREF	A	Reference Voltage Out	-
43	18	VC1	A	Voltage Adjust for Out 1~4	-
44	17	VC2	A	Voltage Adjust for Out 5~8	-
45	16	ISH	A	Voltage Adjust for Shutter(Out9~10)	-
46	15	IAE	A	Voltage Adjust for IRIS(Out11~12)	-
47	14	NC	-	Non Connection	-
48	13	NC	-	Non Connection	-

Internal Block Diagram

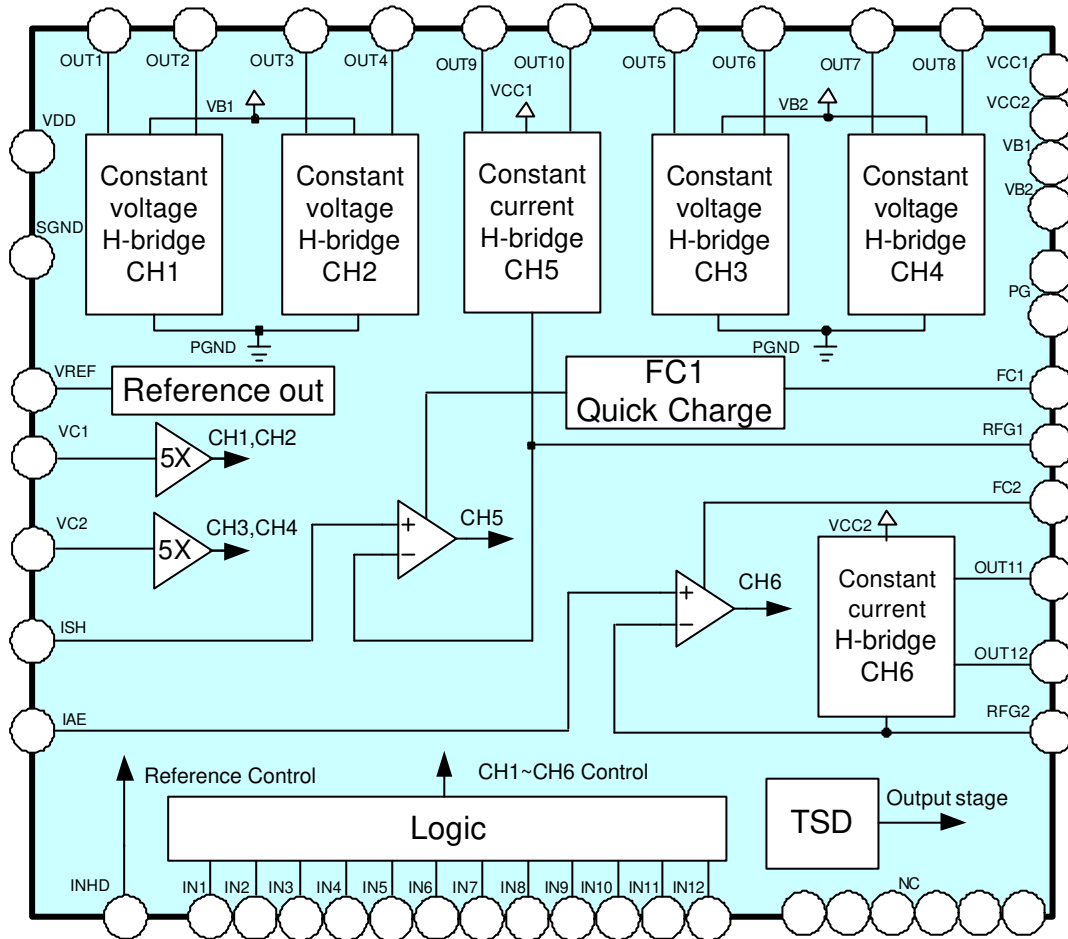

Equivalent Circuits

IN1 ~ IN 12 , INHD Input	VC1 , VC2
ISH , IAE	FC1 , FC2
RFG1 , RFG2	VREF

Notes: Reference of pin number is 48-LQFP-0707

Equivalent Circuits (Continued)

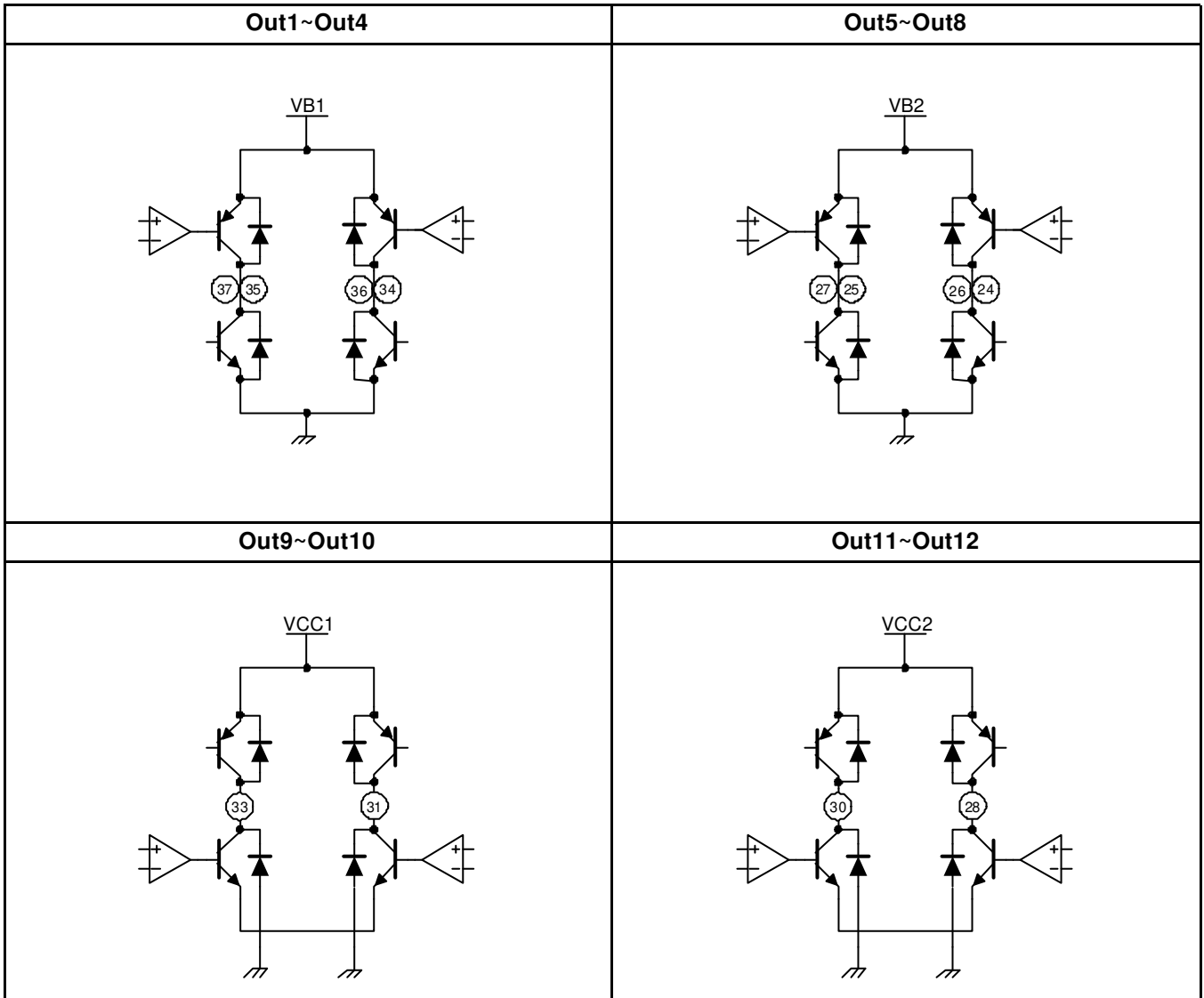

Notes: Reference of pin number is 48-LQFP-0707

Absolute Maximum Ratings (Ta = 25°C)

Parameter	Symbol	Value	Unit
Maximum Power Supply Voltage	VBMAX	10.5	V
Maximum Power Supply Voltage	VCCMAX	10.5	V
Maximum Approval Voltage To Input Pin	VINMAX	10.5	V
Maximum Approval Voltage To Output Pin	VOUTMAX	11.5	V
Maximum Output Current	IOUTMAX	600	mA
Maximum Power Dissipation	PdMAX	1000 (FAN8702/B) ^{Case1}	mW
		1200 (FAN8702MP) ^{Case1}	
		2500 (FAN8702MP) ^{Case2}	
Operating Temperature	TOPR	-20 ~ +80	°C
Storage Temperature	TSTG	-55 ~ +150	°C

Note:

1. Refer: EIA/JESD 51-2 & EIA/JESD 51-3 & EIA/JESD 51-5 & EIA/JESD 51-7
2. Case 1: Single layer PCB with 1 signal plane only, PCB size 76mm × 114mm × 1.6mm.
3. Case 2: Multi layer PCB with 1 signal, 1 power and 1 ground planes, PCB size 76mm × 114mm × 1.6mm, Cu plane sizes for power and ground 74mm × 74mm × 0.035mm, thermal via hole pitch 0.9mm, via hole φ size 0.3mm, 6 via hole.
4. Should not exceed Pd or ASO value.

Power Dissipation Curve

**FAN8702
FAN8702B**

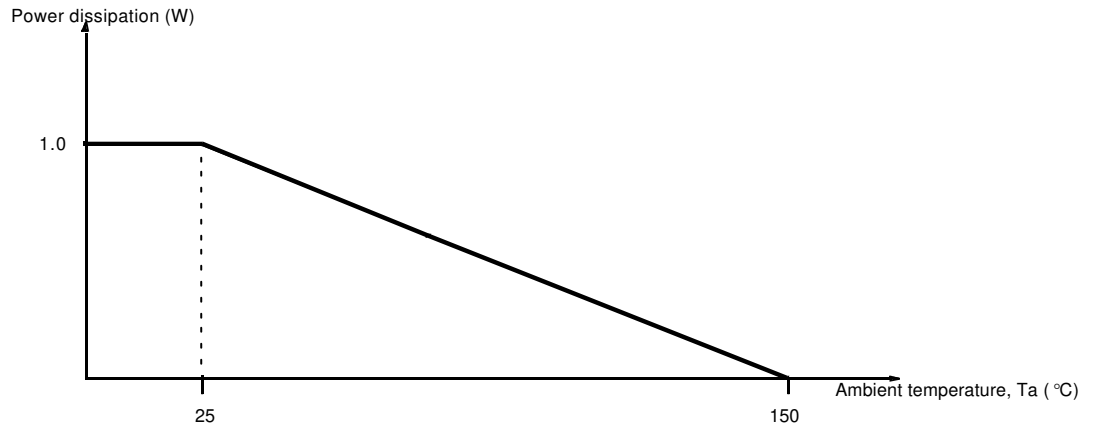

FAN8702MP

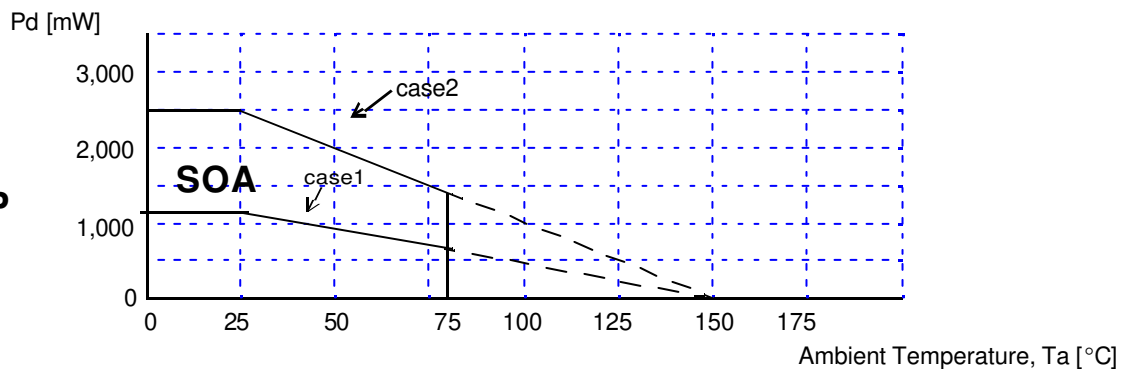

Recommended Operating Conditions (Ta = 25°C)

Parameter	Symbol	Min.	Typ.	Max.	Unit
Operating Voltage Range	VB1,2	2.2	-	6.5	V
Operating Voltage Range	VCC1,2	2.2	-	6.5	V
Logic Input High Level	VINH	1.8	-	7.0	V
Logic Input Low Level	VINL	-0.3	-	0.4	V

Electrical Characteristics

(Ta = 25°C, VB1=VB2=VCC1=VCC2=VDD=2.4V)

Block	Parameter	Symbol	Conditions	Min.	Typ.	Max.	Unit
Total	Stand-by Current	ISTB	VB=VCC=VDD=7.0V	-	-	1.0	μA
	Operating Consumption Current 1	ICC1	IN1~IN8 (1Phase) IOV=200mA, Note1	-	8	11	mA
	Operating Consumption Current 2	ICC2	IN1~IN8(2Phase) IOV=400mA, Note1	-	17	25	mA
	Operating Consumption Current 3	ICC3	IN5~IN8(Brake) Note2	-	16	25	mA
	Operating Consumption Current 4	ICC4	IN9~IN12(1 phase) IOI=200mA, Note1	-	6	11	mA
	Operating Consumption Current 5	ICC5	IN11,IN12(Brake)Note2	-	16	25	mA
	Reference Voltage Output Voltage 1	VREF1	IREF=-1mA, INHD=L	0.95	1.0	1.05	V
	Reference Voltage Output Voltage 2	VREF2	IREF=-1mA, INHD=H	0.64	0.67	0.70	V
	Logic Input High Current	IINH	VIN=5.0V	-	60	90	μA
	Logic Input Low Current	IINL	VIN=0.0V	-1	-	1	μA
	Thermal Shutdown	THD	-	-	150	-	°C
Current driver	Output Current 1	IO	RFG=1.0Ω, ISH=0.3V	282	300	318	mA
	Output Saturation Voltage (PNP+NPN)	VSAT1	IO=0.3A	-	0.4	0.6	V
Voltage driver	Output Voltage 1	VO	VC1, 2 =0.4V	1.9	2.0	2.1	V
	Output Saturation Voltage (PNP+NPN)	VSAT2	IO=0.2A	-	0.35	0.50	V

Note :

1. ICC1, ICC2, ICC4 is sum of the current consumption VB1, VB2, VCC1, VCC2 line.
2. ICC3, ICC5 is sum of the current consumption VB1, VB2, VCC1, VCC2 and VDD line.

Operation Truth Table

Input/ Output Motor Operation	IN 1	IN 2	IN 3	IN 4	IN 5	IN 6	IN 7	IN 8	IN 9	IN 10	IN 11	IN 12	INHD	OUT 1	OUT 2	OUT 3	OUT 4	OUT 5	OUT 6	OUT 7	OUT 8	OUT 9	OUT 10	OUT 11	OUT 12	Vref
Stand-by	L	L	L	L	L	L	L	L	L	L	L	L	L	Z	Z	Z	Z	Z	Z	Z	Z	Z	Z	Z	Z	Z
	L	L	L	L	L	L	L	L	L	L	L	L	H													0.67
	When one of input of IN1 to IN12 is high												L													1.0
	When one of input of IN1 to IN12 is high												H													0.67
Voltage driver 1	L	L											Z	Z												
	L	H											L	H												
	H	L											H	L												
	H	H											Z	Z												
Voltage driver 1			L	L									Z	Z												
			L	H									L	H												
			H	L									H	L												
			H	H									Z	Z												
Voltage driver 2					L	L						Z	Z													
					L	H						L	H													
					H	L						H	L													
					H	H						L	L													
Current driver 1									L	L					Z	Z										
									L	H					L	H										
									H	L					H	L										
									H	H					FAN8702 only				Inhibit							
								FAN8702B and FAN8702MP				Z	Z													
Current driver 2											L	L					Z	Z								
											L	H					L	H								
											H	L					H	L								
											H	H					L	L								

Application Information

1. Current Drive Output Current Setting

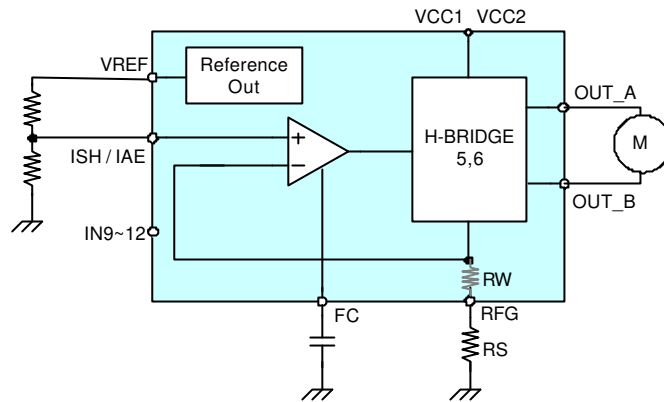

Motor current is determined by ISH/IAE voltage and R_s sensing resistance and calculated by the formula below considering R_w . Generally internal bonding and metal resistance R_w is around 0.05Ω .

$$\text{Motor Current} = \frac{\text{ISH or IAE Input Voltage}}{R_s + R_w}$$

2. Current Drive Block1(CH5)

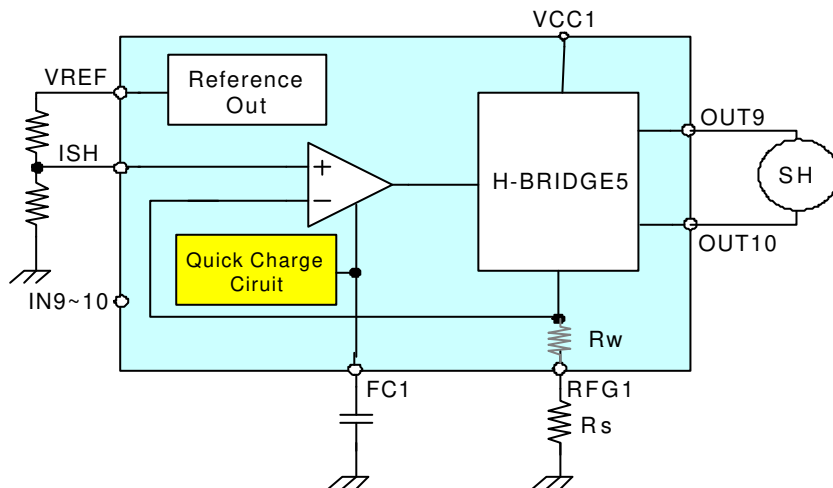

If there is no capacitor on the exterior of the FC terminal or low capacitance is used, it may cause oscillation or overshoot at output terminal. The output stage will not be operating until FC1 terminal voltage reaches around 0.7V (Typical)
 The output response time depends on the FC1 capacitance and interval of Input signal. Generally, the quick charging time is 10us~20us. To minimize the delay time difference in the output response between high-speed shutter and bulb shutter a quick charging circuit is built in.

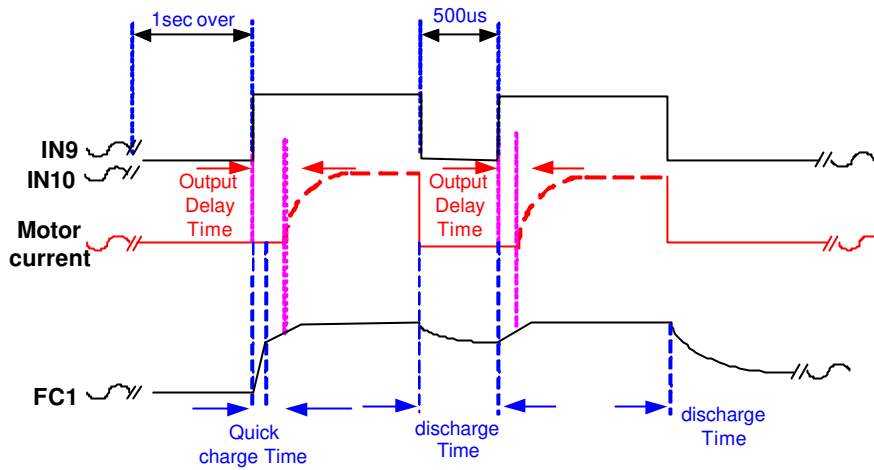

3. Current Drive block2(CH6)

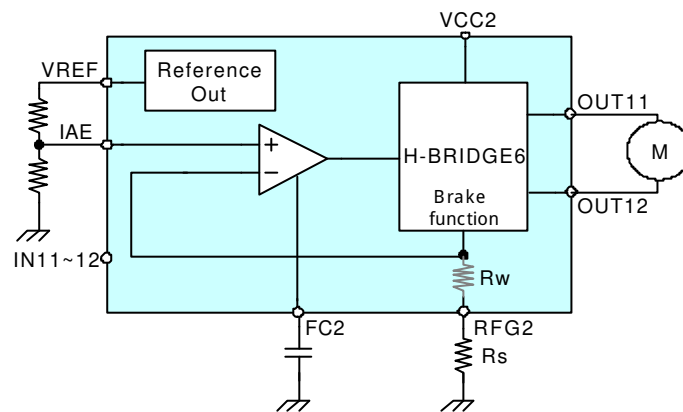

The output response time depends on the FC2 capacitance and interval of Input signal because there is no FC quick charging circuit in current drive2.

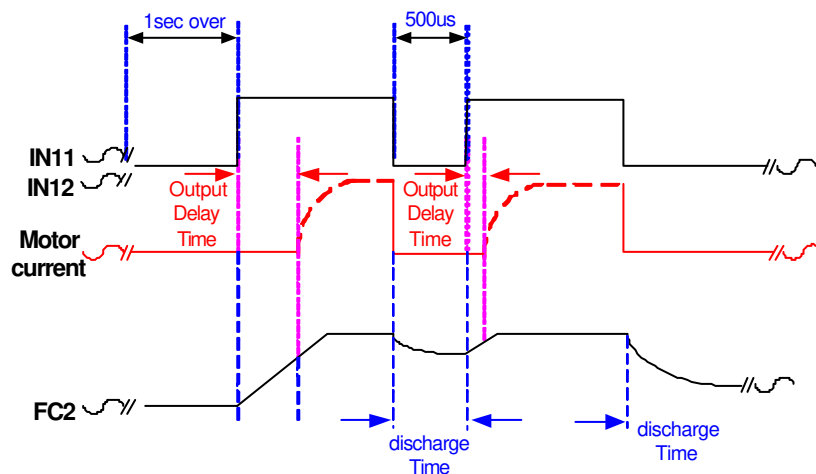

4. Voltage Drive Block

The output voltage as much as 5 times the input voltage V_{C1}, V_{C2} is produced in the range of motor power V_{B1}/V_{B2} . If output oscillation occur during constant voltage drive, then $0.01\mu F \sim 0.1\mu F$ capacitor should be installed on the both sides of the output.

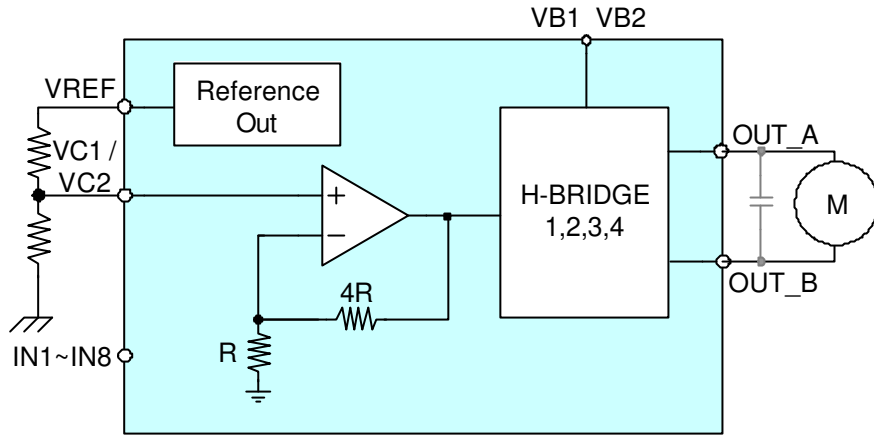

5. H-Bridge Drive Mode

A H-bridge drive mode can be implemented using the current drive block or the voltage drive block.

1) H- bridge drive using current drive block

The current drive block using the H-bridge method can be operated with ISH/AE connected to V_{REF} or supply input, with the FC terminal open and sensing terminal connected to ground.

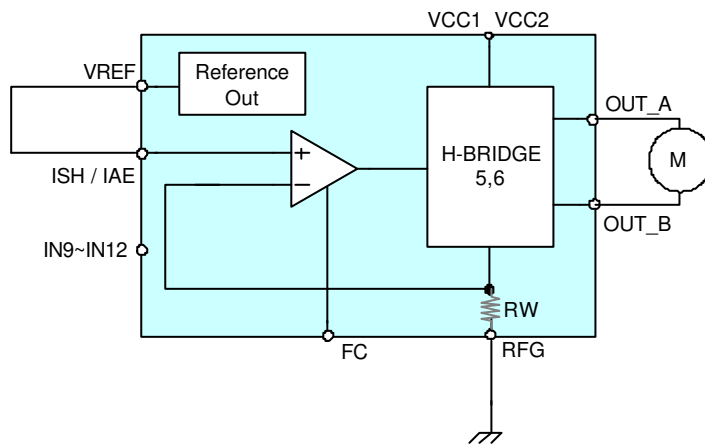

2) H- bridge drive using voltage drive block

When VB1 and VB2 power is less than 5V, VC1/VC2 input should be connected to VREF or motor supply and VB1 and VB2 power is more than 5V, VC1/VC2 input should be connected to motor supply. In H-bridge drive mode, a capacitor to prevent oscillation is not necessary on both sides of the output.

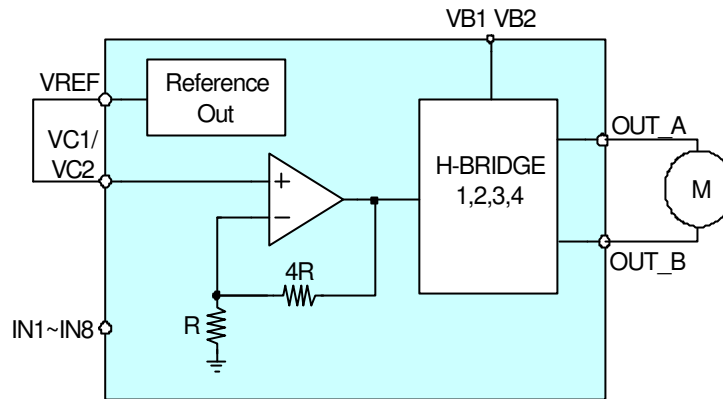

6. Short through protection

When a motor is driven, high/low side TR turn on simultaneously. This range may cause power to be shorted to ground momentarily. To prevent a short through, output is generated with a 1.8us(typical) delay after a high input signal.

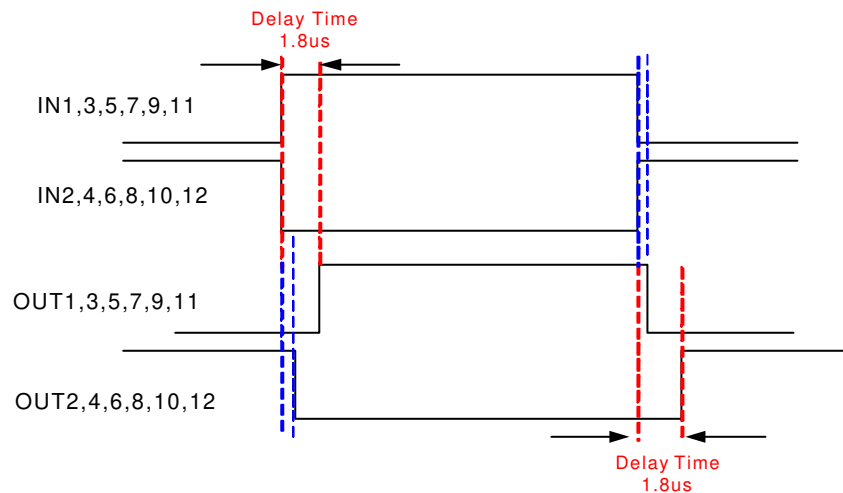

7. Brake function

The brake function is built in Ch3,4 and CH6 . Using the H/H signal on input, it is designed so that a short brake is operated on output.

8. Power Supply

VB1,VB2,VCC1 and VCC2 are separated for motor power of FAN8702 and VDD is used for IC logic power. VB1,VB2,VCC1 and VCC2 are correspond to H-bridge 1~2, H-bridge 3~4, H-bridge 5 and H-bridge6.

9. Thermal shutdown

When thermal shut down is activated, all the outputs become off except for VREF.

Typical Application Circuits1

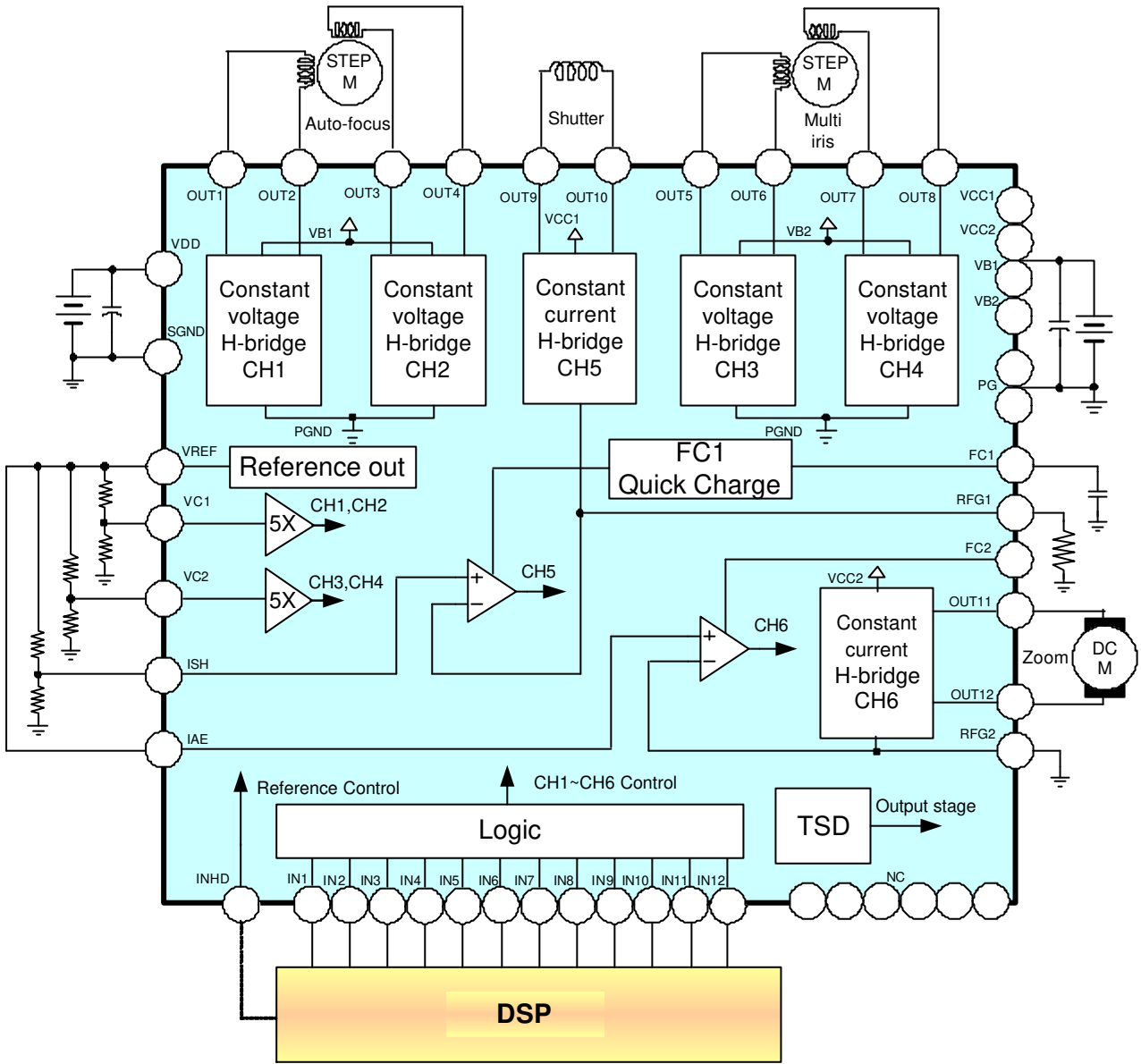

Package Dimensions (Unit: mm)

48MLP 7x7

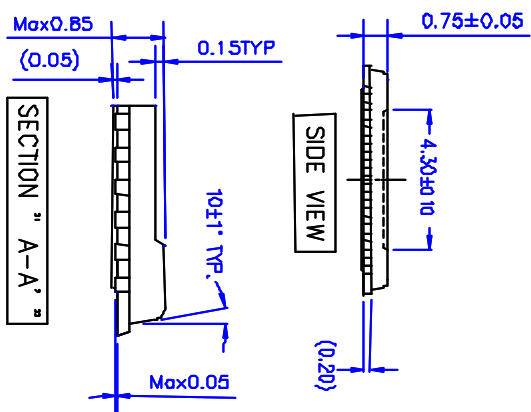
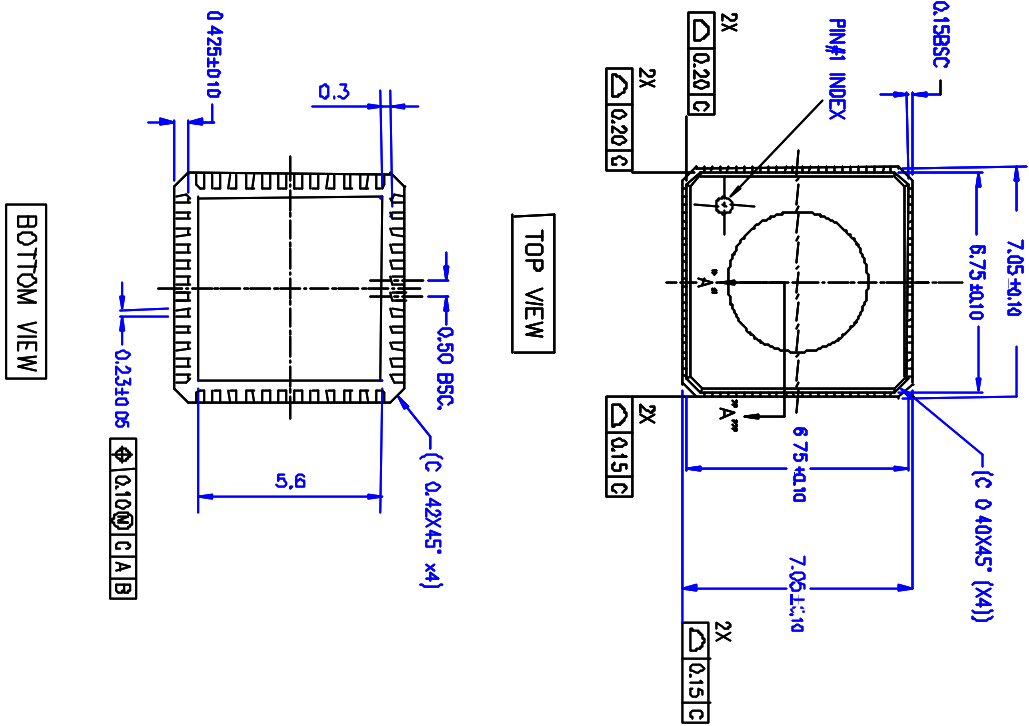

NOTES :

1. PACKAGE DIMENSIONS CONFORM TO JEDEC MO-220 (MKD-2)
2. DIMENSIONING AND TOLERANCING CONFORM TO ASME Y 14.5M - 1994.
3. LEAD NUMBERS START WITH THE #1 AND CONTINUE COUNTERCLOCKWISE TO LEAD #48 WHEN VIEWED FROM THE TOP.
4. PIN #1 INDEX MUST BE INDICATED BY LASER MARK.
5. MAXIMUM ALLOWABLE BURR SHALL NOT EXCEED 0.05MM.

Recommended PCB Design for FAN8702MP(Unit: mm)

RECOMMEND DESIGN WITH VIA HOLE ON THE LAND

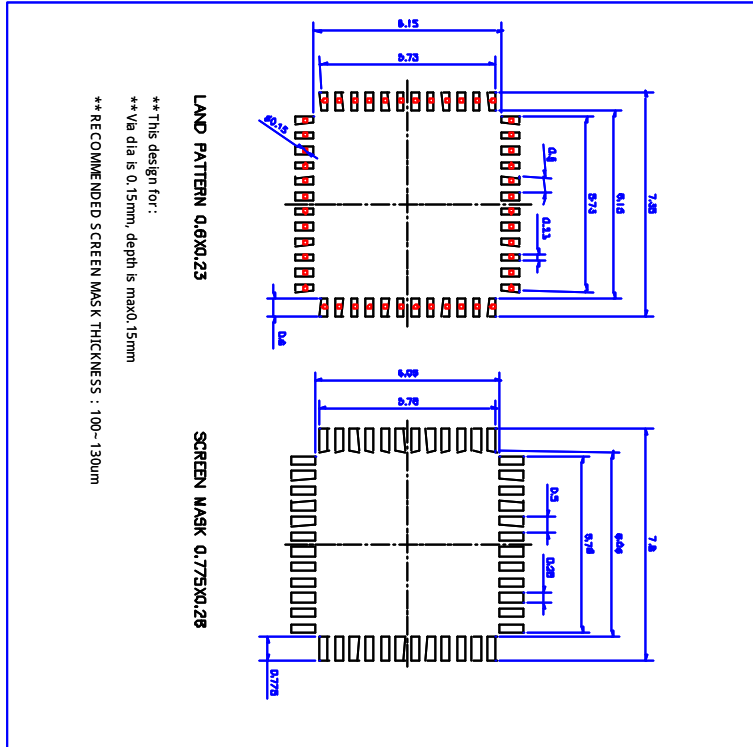

RECOMMEND DESIGN WITH VIA HOLE ON THE LAND

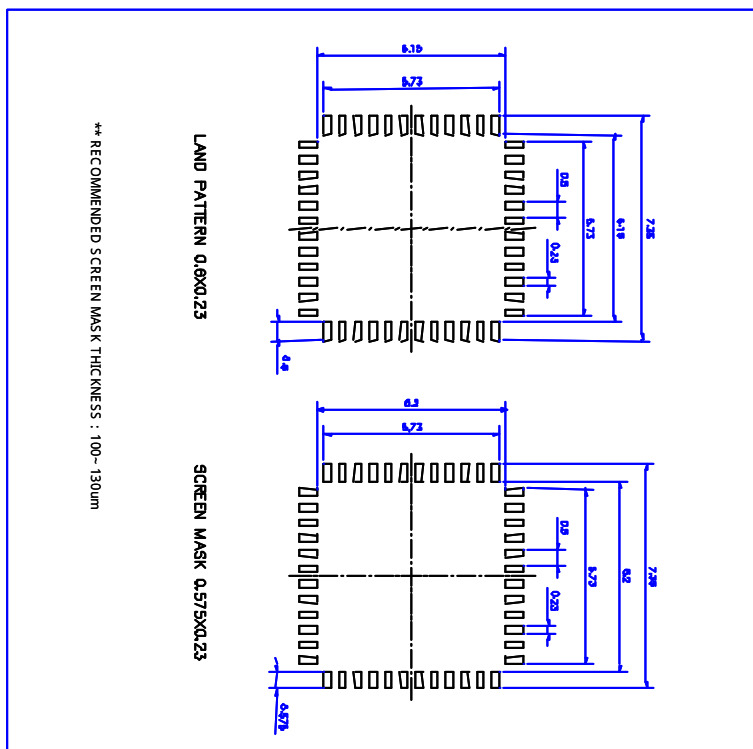

DISCLAIMER

FAIRCHILD SEMICONDUCTOR RESERVES THE RIGHT TO MAKE CHANGES WITHOUT FURTHER NOTICE TO ANY PRODUCTS HEREIN TO IMPROVE RELIABILITY, FUNCTION OR DESIGN. FAIRCHILD DOES NOT ASSUME ANY LIABILITY ARISING OUT OF THE APPLICATION OR USE OF ANY PRODUCT OR CIRCUIT DESCRIBED HEREIN; NEITHER DOES IT CONVEY ANY LICENSE UNDER ITS PATENT RIGHTS, NOR THE RIGHTS OF OTHERS.

LIFE SUPPORT POLICY

FAIRCHILD' S PRODUCTS ARE NOT AUTHORIZED FOR USE AS CRITICAL COMPONENTS IN LIFE SUPPORT DEVICES OR SYSTEMS WITHOUT THE EXPRESS WRITTEN APPROVAL OF THE PRESIDENT OF FAIRCHILD SEMICONDUCTOR CORPORATION. As used herein:

1. Life support devices or systems are devices or systems which, (a) are intended for surgical implant into the body, or (b) support or sustain life, and (c) whose failure to perform when properly used in accordance with instructions for use provided in the labeling, can be reasonably expected to result in a significant injury of the user.
2. A critical component in any component of a life support device or system whose failure to perform can be reasonably expected to cause the failure of the life support device or system, or to affect its safety or effectiveness.