

SECTION A-A

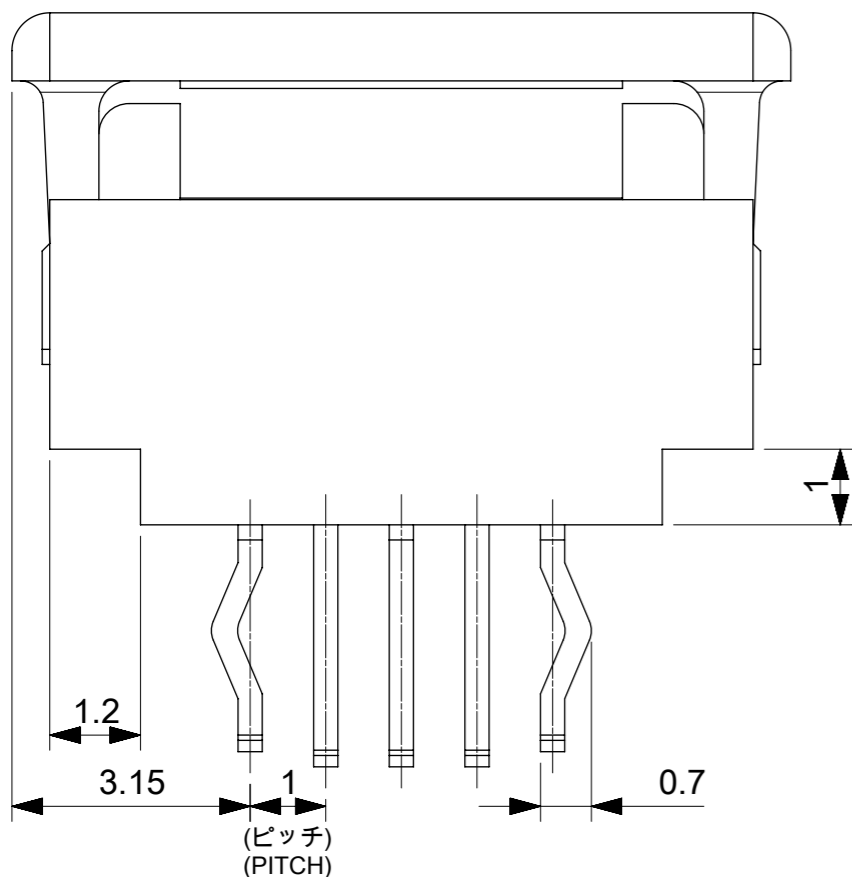

注記 NOTES

- △1 CKT.NO.1を基準に偶数番目のソルダーテール。
EVEN NO. SOLDER TAIL.
- △2 CKT.NO.1を基準に奇数番目のソルダーテール。
ODD NO. SOLDER TAIL.
- 3. 材料 MATERIAL
ハウジング : ポリアミド(PA)、ナチュラル、UL94V-0
HOUSING : POLYAMIDE, NATURAL, UL94V-0
アクチュエータ : ポリエステル(PBT)、
ナチュラル、UL94V-0
ACTUATOR : POLYBUTYLENE TEREPHTHALATE,
NATURAL, UL94V-0
ターミナル : リン青銅(t=0.32)
TERMINAL : PHOSPHOR BRONZE(t=0.32)
- 4. めっき仕様 PLATING
ターミナル TERMINAL
接点部 : 金めっき(0.1µm以上)
CONTACT AREA : GOLD PLATING(0.1µm MIN.)
テール部 : 錫めっき(1.0µm以上)
TAIL AREA : TIN PLATING(1.0µm MIN.)
下地 : ニッケルめっき(1.0µm以上)
UNDER PLATING : NICKEL PLATING(1.0µm MIN.)
- 5. 本製品は、52030シリーズの金めっき品である。
THIS PRODUCT IS GOLD PLATING OF 52030.

25.3	21.2	52030-2075	20
22.3	18.2	52030-1775	17
21.3	17.2	52030-1675	16
20.3	16.2	52030-1575	15
18.3	14.2	52030-1375	13
17.3	13.2	52030-1275	12
16.3	12.2	52030-1175	11
15.3	11.2	52030-1075	10
14.3	10.2	52030-0975	9
B	A	オーダー番号 ORDER NO.	極数 CKT.

THIS DRAWING CONTAINS INFORMATION THAT IS PROPRIETARY TO MOLEX ELECTRONIC TECHNOLOGIES, LLC AND SHOULD NOT BE USED WITHOUT WRITTEN PERMISSION

EC NO: 112372 DRWN: MTAKAHASHI04 CHK'D: YKOBAYASHI02 APPR: TKUSUHARA01	2017/01/13	2017/01/13	2017/01/13	GENERAL TOLERANCES (UNLESS SPECIFIED) ANGULAR TOL ± 3.0 ° 4 PLACES ± 0.2 3 PLACES ± 0.2 2 PLACES ± 0.2 1 PLACE ± 0.25 0 PLACES ± 0.3 DRAFT WHERE APPLICABLE MUST REMAIN WITHIN DIMENSIONS	DIMENSION UNITS	SCALE	
	REVISED				MM	10:1	
		JASANUMA	2015/12/04		DRWN BY	DATE	
		KTAKAHASHI	2015/12/08		CHK'D BY	DATE	
		YNOGAWA	2015/12/09		APPR BY	DATE	
	A3	THIRD ANGLE PROJECTION			PRODUCT CUSTOMER DRAWING SERIES: 52030 MATERIAL NUMBER: SEE CHART CUSTOMER: GENERAL		
					DRAWING SIZE: A3 DOCUMENT NUMBER: 520301001 DOC TYPE: PSD DOC PART: 000 SHEET NUMBER: 1 OF 2		

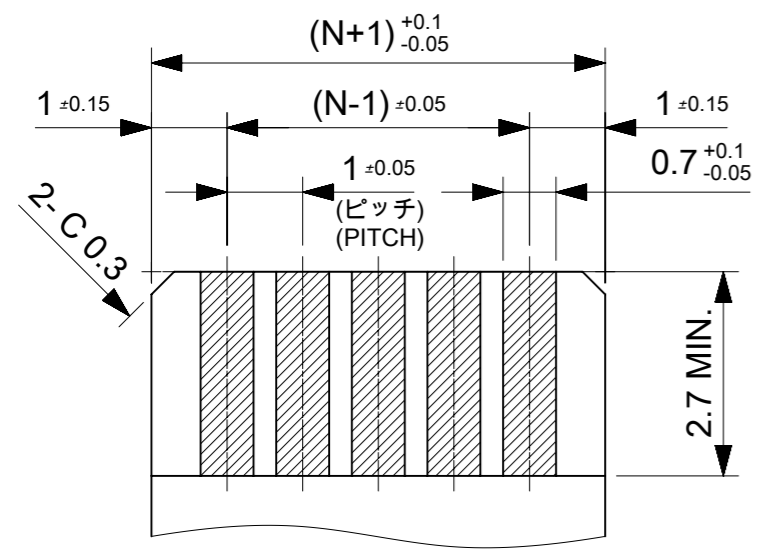

(仕上がり厚さ:0.3±0.05)
(THICKNESS:0.3±0.05)

適合FPC/FFC推奨寸法
APPLICABLE FPC/FFC RECOMMENDED DIM.

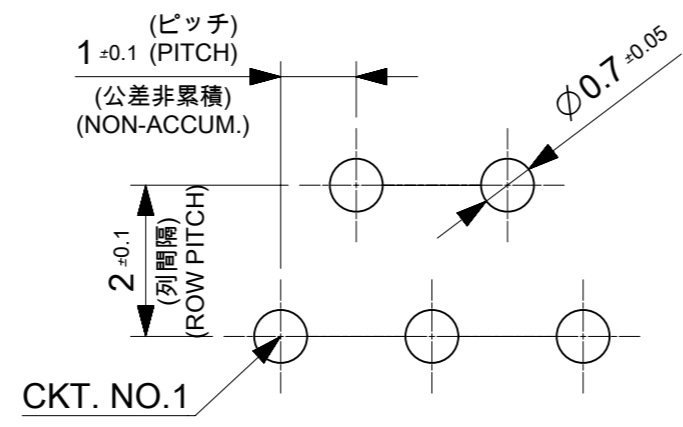

基板取付穴推奨寸法(t=1.6)
RECOMMENDED
P.C.BOARD HOLE DIM.(t=1.6)
(マウント面)
(MOUNT SURFACE)

FPC/FFCについて

打ち抜き方向は導体側から補強板側を推奨致します。
導体部については軟箔銅35µmまたは50µmを推奨致します。
接着剤の接点部への付着は導通不良の原因になりますので、
染み出しが無い様お願い致します。
FPC/FFCに規定された定格温度がFPC/FFC単体前提である場合が御座います。
コネクタと組み合わせての実使用において、接着層が劣化する等の信頼性を
満足できないケースを回避する為、実機での評価/確認をお願い致します。

ABOUT FPC/FFC

RECOMMENDED PUNCHING DIRECTION:
FROM CONDUCTOR SIDE TO STIFFENER SIDE
RECOMMENDED CONDUCTOR SPEC: SOFT COPPER FOIL
RECOMMENDED CONDUCTOR THICKNESS: 35 MICROMETER OR 50 MICROMETER

PLEASE PUT APPROPRIATE AMOUNT OF ADHESIVE ON ADHEREND BECAUSE
THERE IS A POSSIBILITY THAT EXTRA ADHESIVE CAUSES THE DEFECT IN
ELECTRICAL CONTINUITY THE HEAT RESISTANCE OF FFC IS ONLY FFC SPEC
TO PREVENT THE CASE THAT RELIABILITY CANNOT BE SATISFIED
(THE ADHESIVE IS DETERIORATED etc.) PLEASE DO THE EVALUATION
AND THE CONFIRMATION WITH ACTUAL CONNECTER.

FPCについて

補強フィルム材質はポリイミドを推奨します。ベースフィルムは25µmを推奨します。
接着剤は熱硬化接着剤を推奨します。

ABOUT FPC

RECOMMENDED STIFFENER MATERIAL: POLYIMIDE
RECOMMENDED BASE FILM THICKNESS: 25 MICROMETER
RECOMMENDED ADHESIVE: THERMOSETTING ADHESIVE

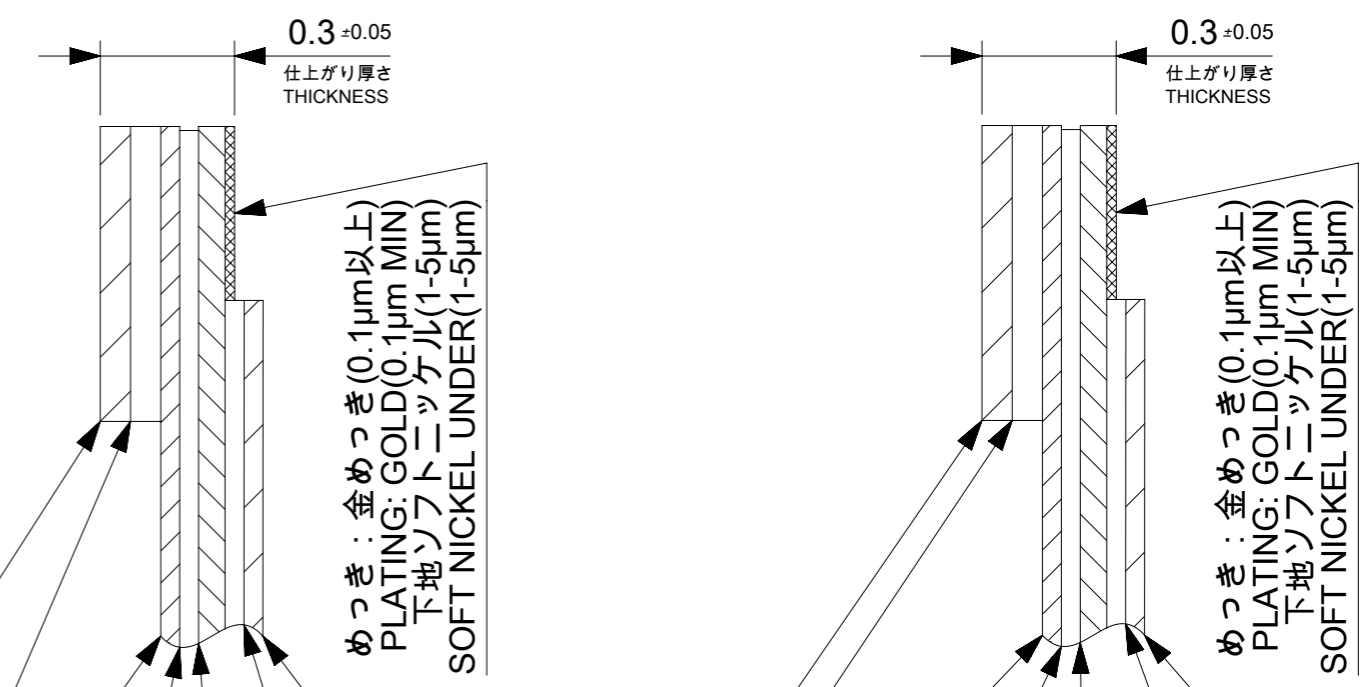

めっき : 金めっき(0.1µm以上)
PLATING: GOLD(0.1µm MIN)
下地ソフトニッケル(1-5µm)
SOFT NICKEL UNDER(1-5µm)

めっき : 金めっき(0.1µm以上)
PLATING: GOLD(0.1µm MIN)
下地ソフトニッケル(1-5µm)
SOFT NICKEL UNDER(1-5µm)

- 補強板 : ポリイミド
REINFORCE BOARD: POLYIMIDE
- 熱硬化接着剤
THERMOSETTING ADHESIVE
- ベースフィルム : ポリイミド(25µm)
BASE FILM: POLYIMIDE(25µm)
- 熱硬化接着剤
THERMOSETTING ADHESIVE
- 導体部 : 銅箔(35µm)
COPPER FOIL (35µm)
- 熱硬化接着剤
THERMOSETTING ADHESIVE
- カバーレイ : ポリイミド(25µm)
COVER FILM: POLYIMIDE(25µm)

FPC構成推奨仕様
STRUCTURE OF FPC

- 補強板 : ポリエステル系
REINFORCE BOARD: PET
- 接着剤(難燃ポリエステル系)
ADHESIVE (FLAME-RETARDANT
POLYESTER ADHESIVE)
- 絶縁テープ : ポリエステル系(25µm)
INSULATING FILM: PET(25µm)
- 接着剤(難燃ポリエステル系)
ADHESIVE (FLAME-RETARDANT
POLYESTER ADHESIVE)
- 導体部 : 銅箔(35µmか50µm)
COPPER FOIL (35µm or 50µm)
- 接着剤(難燃ポリエステル系)
ADHESIVE (FLAME-RETARDANT
POLYESTER ADHESIVE)
- 絶縁テープ : ポリエステル系(25µm)
INSULATING FILM: PET(25µm)

FFC構成推奨仕様
STRUCTURE OF FFC

THIS DRAWING CONTAINS INFORMATION THAT IS PROPRIETARY TO MOLEX ELECTRONIC TECHNOLOGIES, LLC AND SHOULD NOT BE USED WITHOUT WRITTEN PERMISSION										
REVISED	2017/01/13	GENERAL TOLERANCES (UNLESS SPECIFIED)		DIMENSION UNITS	SCALE					
	2017/01/13	ANGULAR TOL ± 3.0 °		MM	1:1					
	2017/01/13	4 PLACES	± 0.2	DRWN BY	DATE					
		3 PLACES	± 0.2	JASANUMA	2015/12/04					
		2 PLACES	± 0.2	CHK'D BY	DATE					
		1 PLACE	± 0.25	KTAKAHASHI	2015/12/08	PRODUCT CUSTOMER DRAWING				
		0 PLACES	± 0.3	APPR BY	DATE	SERIES	MATERIAL NUMBER	CUSTOMER		
		DRAFT WHERE APPLICABLE MUST REMAIN WITHIN DIMENSIONS		YNOGAWA	2015/12/09	52030	SEE CHART	GENERAL		
				DRAWING SIZE	THIRD ANGLE PROJECTION	DOCUMENT NUMBER	DOC TYPE	DOC PART	SHEET NUMBER	
				A3		520301001	PSD	000	2 OF 2	