

## Description

The DIODES™ PAM2861 is a continuous mode inductive step-down converter, designed for driving single or multiple series connected LEDs efficiently from a voltage source higher than the LED voltage. The device operates from an input supply between 6V and 40V and provides an externally adjustable output current of up to 1A. Depending upon supply voltage and external components, this can provide up to 30 watts of output power.

The PAM2861 includes the output switch and a high-side output current sensing circuit, which uses an external resistor to set the nominal average output current.

Output current can be adjusted below the set value, by applying an external control signal to the VSET pin.

The VSET pin will accept either a DC voltage or a PWM waveform.

The soft-start time can be increased using an external capacitor from the VSET pin to ground. Applying a voltage of 0.2V or lower to the VSET pin turns the output off and switches the device into a low current standby state.

## Features

- Simple Low Parts Count
- Internal 40V NDMOS Switch
- 1A Output Current
- Single Pin On/Off and Brightness Control Using DC Voltage or PWM
- Soft-Start
- High Efficiency (Up to 97%)
- Wide Input Voltage Range: 6V to 40V
- Output Shutdown
- Open LED Protection
- Short LED Protection
- Up to 1MHz Switching Frequency
- Inherent Open-Circuit LED Protection
- Typical 5% Output Current Accuracy
- Pb-Free TSOT25 and SOT89-5 Packages
- **Totally Lead-Free & Fully RoHS Compliant (Notes 1 & 2)**
- **Halogen and Antimony Free. “Green” Device (Note 3)**
- **For automotive applications requiring specific change control (i.e. parts qualified to AEC-Q100/101/104/200, PPAP capable, and manufactured in IATF 16949 certified facilities), please [contact us](mailto:contact@diodes.com) or your local Diodes representative.**

<https://www.diodes.com/quality/product-definitions/>

- Notes:
1. No purposely added lead. Fully EU Directive 2002/95/EC (RoHS), 2011/65/EU (RoHS 2) & 2015/863/EU (RoHS 3) compliant.
  2. See <https://www.diodes.com/quality/lead-free/> for more information about Diodes Incorporated's definitions of Halogen- and Antimony-free, "Green" and Lead-free.
  3. Halogen- and Antimony-free "Green" products are defined as those which contain <900ppm bromine, <900ppm chlorine (<1500ppm total Br + Cl) and <1000ppm antimony compounds.

## Pin Assignments

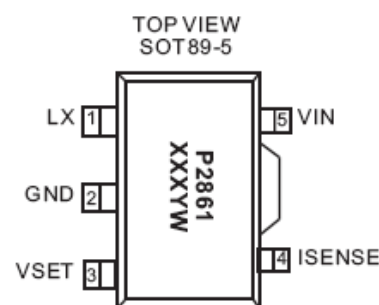
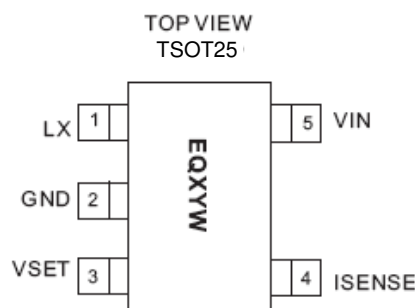

## Applications

- Low voltage halogen replacement LEDs
- Low voltage industrial lightings
- LED back-side lightings
- Illuminated signs

**Typical Applications Circuit**

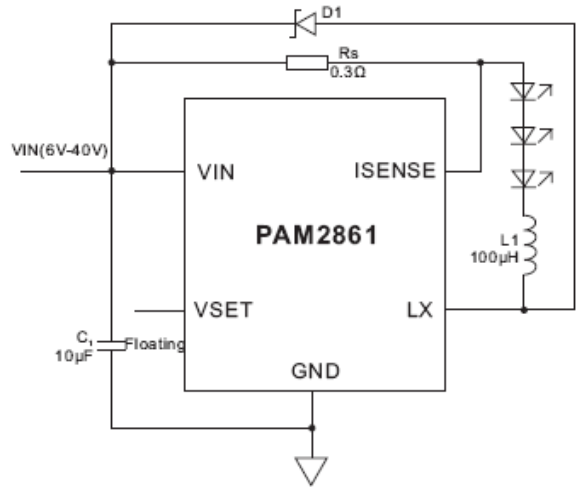

**Pin Descriptions**

Pin Number	Pin Name	Function
1	LX	Drain of NDMOS switch.
2	GND	Ground (0V)
3	VSET	<ul style="list-style-type: none"> <li>Multi-function On/Off and brightness control pin:</li> <li>Leave floating for normal operation.</li> <li>Drive to voltage below 0.2V to turn off output current</li> <li>Drive with DC voltage (<math>0.3V &lt; VSET &lt; 2.5V</math>) to adjust output current from 12% to 100% of <math>I_{OUTnom}</math></li> <li>Drive with PWM signal from open-collector or open-drain transistor, to adjust output current. Adjustment range 1% to 100% of <math>I_{OUTnom}</math> for <math>f &lt; 500Hz</math></li> <li>Connect a capacitor from this pin to ground to increase soft-start time. (Default soft-start time = 0.1ms. Additional soft-start time is approx. 1.5ms/1nF)</li> </ul>
4	ISENSE	Connect resistor $R_S$ from this pin to $V_{IN}$ to define nominal average output current $I_{OUTnom} = 0.1/R_S$
5	$V_{IN}$	Input voltage (6V to 40V). Decouple to ground with 10µF or higher X7R ceramic capacitor close to device.

**Functional Block Diagram**

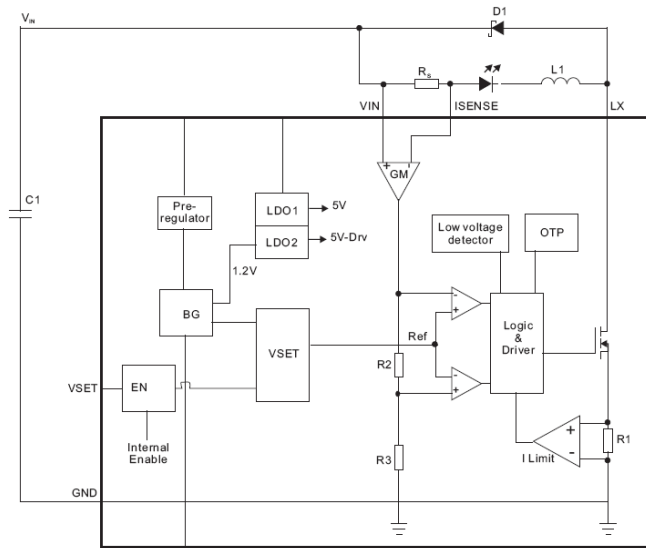

---

### Absolute Maximum Ratings (@T<sub>A</sub> = +25°C, unless otherwise specified.)

---

These are stress ratings only and functional operation is not implied. Exposure to absolute maximum ratings for prolonged time periods can affect device reliability. All voltages are with respect to ground.

Parameter	Rating	Unit
Input Voltage Range	-0.3 to +40	V
LX, ISENSE Pin Voltage	-0.3 to +40	
VSET Pin Voltage	-0.3 to +6.0	
Maximum Junction Temperature	170	°C
Storage Temperature	-65 to +170	
Soldering Temperature	300, 5sec	

---

### Recommended Operating Conditions (@T<sub>A</sub> = +25°C, unless otherwise specified.)

---

Parameter	Rating	Unit
Input Voltage Range	6 to 40	V
Ambient Temperature Range	-40 to +85	°C
Junction Temperature Range	-40 to +150	°C

---

### Thermal Information

---

Parameter	Package	Symbol	Max	Unit
Thermal Resistance (Junction to Ambient)	TSOT25	θ <sub>JA</sub>	250	°C/W
	SOT89-5		160	
Thermal Resistance (Junction to Case)	TSOT25	θ <sub>JC</sub>	130	
	SOT89-5		45	

**Electrical Characteristics** (@T<sub>A</sub> = +25°C, V<sub>IN</sub> = 16V, unless otherwise specified.)

Parameter	Symbol	Test Conditions	Min	Typ	Max	Unit
Input Voltage	V <sub>IN</sub>	—	6	—	40	V
Output Current	I <sub>LED</sub>	R <sub>S</sub> = 0.3Ω	—	333	—	mA
		R <sub>S</sub> = 0.1Ω	—	1	—	A
Shutdown Current	I <sub>SD</sub>	VSET Pin Grouded	—	20	40	μA
Quiescent Current without Switching	I <sub>Q</sub>	VSET Pin Floating, V <sub>IN</sub> = 16V	—	0.6	—	mA
Mean Current Sense Threshold Voltage	V <sub>SENSE</sub>	Measured on I <sub>SENSE</sub> Pin with Respect to V <sub>IN</sub>	95	100	105	mV
Sense Threshold Hysteresis	V <sub>SENSE_HYS</sub>	—	—	±13	—	%
I <sub>SENSE</sub> Pin Input Current	I <sub>SENSE</sub>	V <sub>SENSE</sub> = V <sub>IN</sub> - 0.1	—	8	—	μA
VSET Range on VSET Pin	V <sub>EN</sub>	For DC Dimming	0.3	—	2.5	V
DC Voltage on VSET Pin to Enable	V <sub>EN(ON)</sub>	V <sub>EN</sub> Rising	—	0.25	—	V
DC Voltage on VSET Pin to Disable	V <sub>EN(OFF)</sub>	V <sub>EN</sub> Falling	—	0.2	—	V
LX Switch On Resistance	R <sub>LX</sub>	@I <sub>LX</sub> = 100mA	—	0.3	—	Ω
LX Switch Leakage Current	I <sub>LX(LEAK)</sub>	—	—	—	5	μA
Soft Start Time	T <sub>SS</sub>	V <sub>IN</sub> = 16V, C <sub>EN</sub> = 1nF	—	1.5	—	ms
Operating Frequency	FLX	V <sub>I</sub> = 16V, V <sub>O</sub> = 9.6V (3 LEDs) L = 47μF, ΔI = 0.25A (I <sub>LED</sub> = 1A)	—	233	—	kHz
Recommended Minimum Switch ON Time	T <sub>ON_REC</sub>	For 4% Accuracy	—	500	—	Ns
Recommended Maximum Switch Frequency	FLX(MAX)	—	—	—	1.0	MHz
Max Duty Circle	—	—	—	98	—	%
Recommended Duty Cycle Range	DLX	—	25	—	75	%
Internal Comparator Propagation Delay (Note 4)	T <sub>PD</sub>	—	—	45	—	ns
Over Temperature Protection	T <sub>OTP</sub>	—	—	150	—	°C
Temp Protection Hysteresis	T <sub>OTP_HYS</sub>	—	—	40	—	°C
Current Limit	I <sub>XL(MAX)</sub>	Peak Inductor Current	1.5	—	—	A

Note: 4. Parameters are not tested at production, but guaranteed by design.

**Typical Performance Characteristics** (@ $T_A = +25^\circ\text{C}$ ,  $V_{IN} = 16\text{V}$ , unless otherwise specified.)

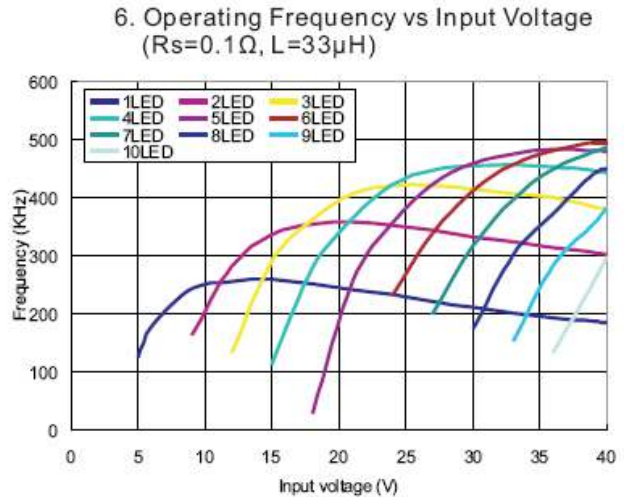
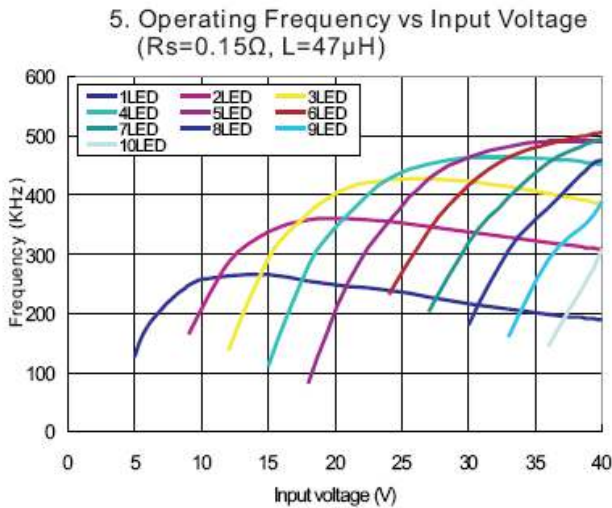
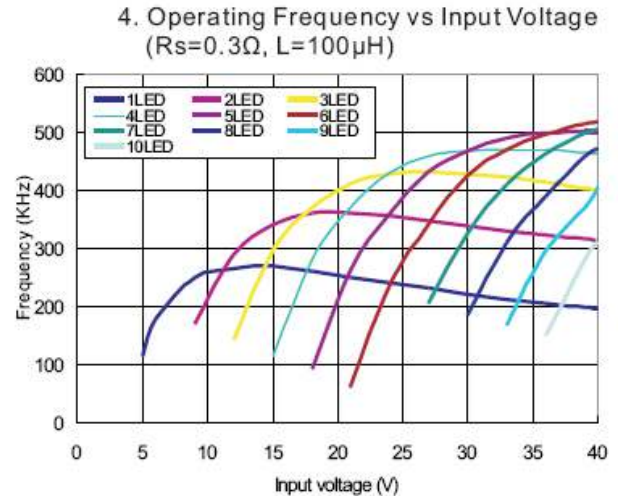
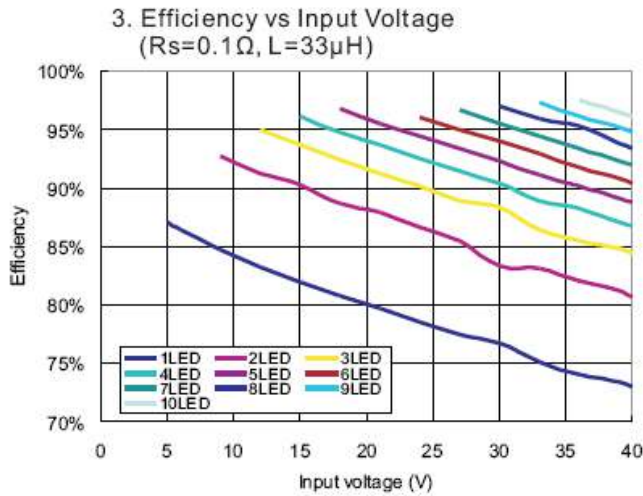
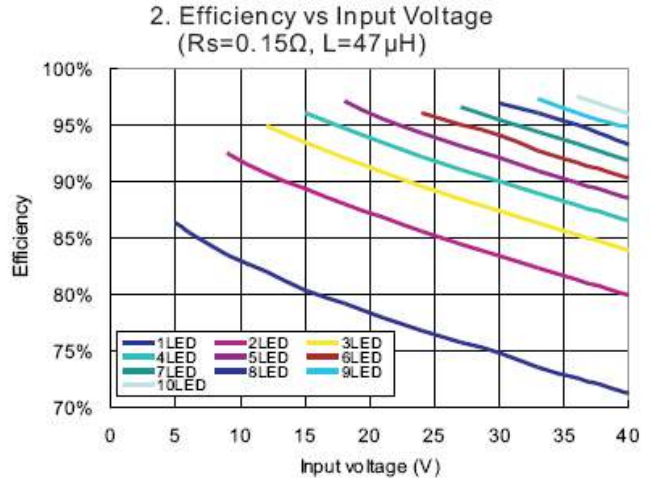
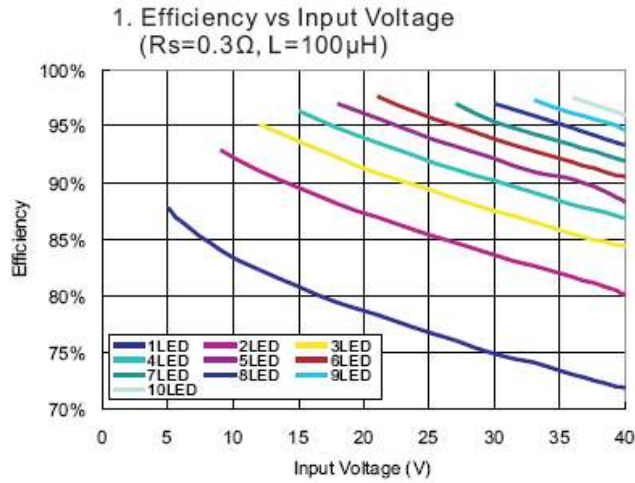

**Typical Performance Characteristics** (continued) (@T<sub>A</sub> = +25°C, V<sub>IN</sub> = 16V, unless otherwise specified.)

7. Quiescent Current VS. Input Voltage

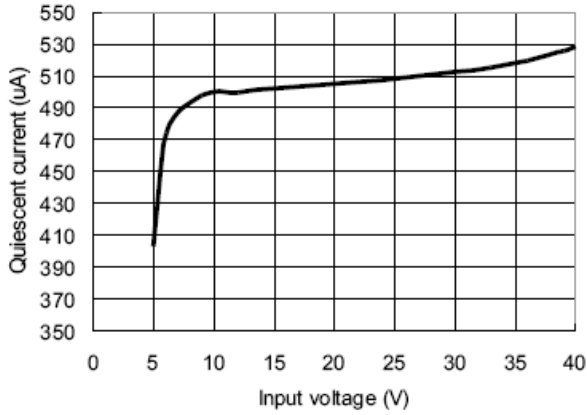

8. Shutdown Current VS. Input Voltage

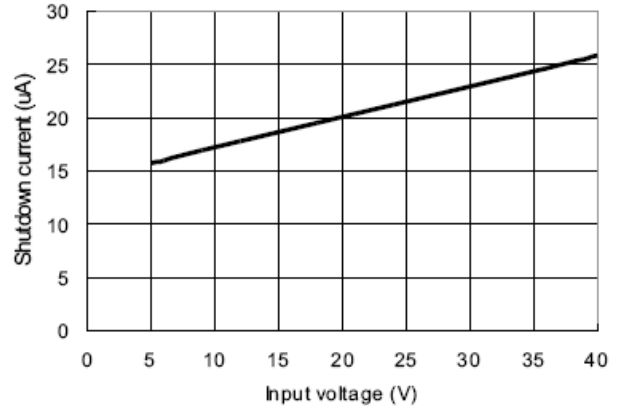

9. Feedback Voltage VS Vin

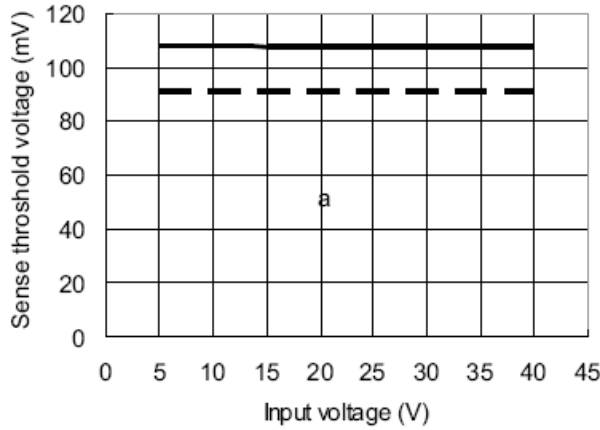

10. Duty Cycle VS LED Current (PWM=200Hz)

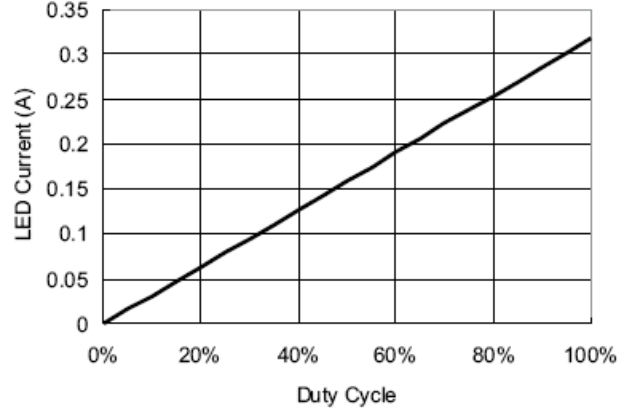

11. I<sub>LED</sub> VS V<sub>SET</sub> (V<sub>IN</sub>=16V, 3 LEDs, 100µH, R<sub>S</sub>=0.3Ω)

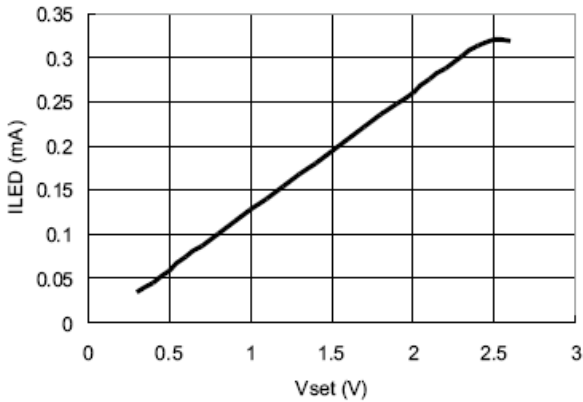

12. I<sub>LED</sub> VS V<sub>SET</sub> (V<sub>IN</sub>=16V, 3 LEDs, 47µH, R<sub>S</sub>=0.15Ω)

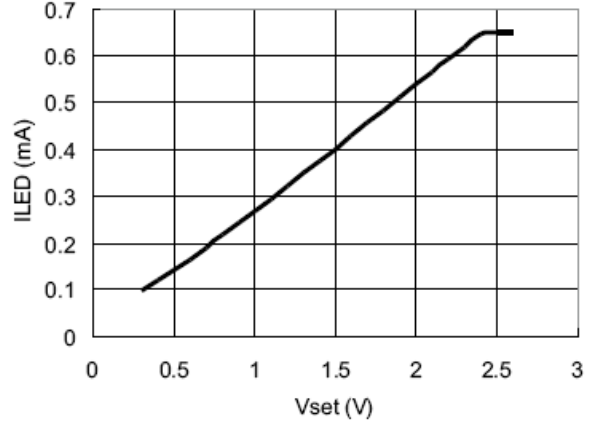

**Typical Performance Characteristics** (continued) (@ $T_A = +25^\circ\text{C}$ ,  $C_{IN} = 10\mu\text{F}$ ,  $C_O = 10\mu\text{F}$ ,  $L = 4.7\mu\text{H}$ , unless otherwise specified.)

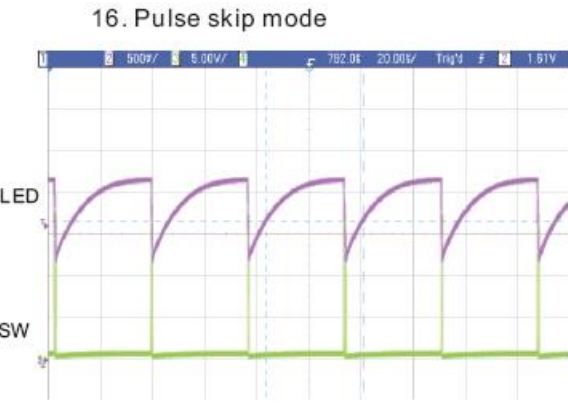
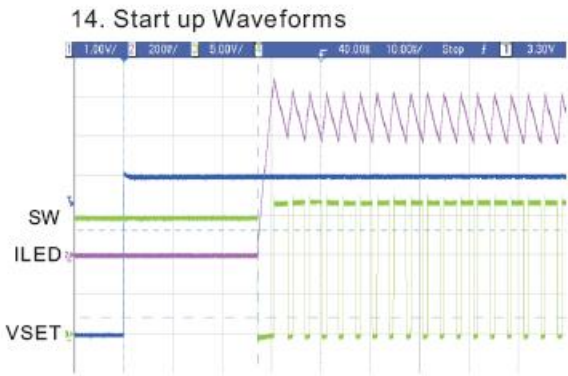
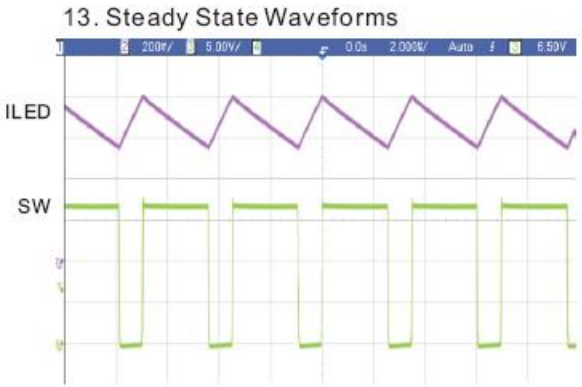



## Application Information

### Setting Nominal Average Output Current with External Resistor $R_S$

The nominal average output current in the LED(s) is determined by the value of the external current sense resistor ( $R_S$ ) connected between VIN and ISENSE and is given by:

$$I_{OUT(NOM)} = \frac{0.1}{R_S}$$

The table below gives values of nominal average output current for several preferred values of current setting resistor ( $R_S$ ) in the typical application circuit shown on page 1.

$R_S$ ( $\Omega$ )	Nominal Average Output Current (mA)
0.1	1000
0.13	760
0.15	667
0.3	333

The above values assume that the VSET pin is floating and at a nominal voltage of VREF (1.25V). Note that  $R_S = 0.1\Omega$  is the minimum allowed value of sense resistor under these conditions to maintain switch current below the specified maximum value. It is possible to use different values of  $R_S$  if the VSET pin is driven from an external voltage.

### Capacitor Selection

A low ESR capacitor should be used for input decoupling, as the ESR of this capacitor appears in series with the supply source impedance and lowers overall efficiency. This capacitor has to supply the relatively high peak current to the coil and smooth the current ripple on the input supply. A minimum value of  $4.7\mu\text{F}$  is acceptable if the input source is close to the device, but higher values will improve performance at lower input voltages, especially when the source impedance is high. The input capacitor should be placed as close as possible to the IC.

For maximum stability over temperature and voltage, capacitors with X7R, X5R, or better dielectric are recommended. Capacitors with Y5V dielectric are not suitable for decoupling in this application and should NOT be used.

### Inductor Selection

Recommended inductor values for the PAM2861 are in the range  $33\mu\text{H}$  to  $100\mu\text{H}$ . Higher values of inductance are recommended at higher supply voltages in order to minimize errors due to switching delays, which in increased ripple and lower efficiency. Higher values of inductance also result in a smaller change in output current over the supply voltage range. The inductor should be mounted as close to the device as possible with low resistance connections to the LX and VIN pins. The chosen coil should have a saturation current higher than the peak output current and a continuous current rating above the required mean output current.

The inductor value should be chosen to maintain operating duty cycle and switch 'on'/'off' times within the specified limits over the supply voltage and load current range. The following equations can be used as a guide.

LX Switch 'On' time

$$T_{ON} = \frac{L\Delta I}{V_{IN} - V_{LED} - I_{LED}(R_S + R_L + R_{LX})}$$

Lx Switch 'Off' time

$$T_{OFF} = \frac{L\Delta I}{V_{LED} + V_D + I_{LED}(R_S + R_L)}$$

Where: L is the coil inductance;  $R_L$  is the coil resistance;  $R_S$  is the current sense resistance;  $I_{LED}$  is the required LED current;  $\Delta I$  is the coil peak-peak ripple current (Internally set to  $0.25 \times I_{LED}$ );  $V_{IN}$  is the supply voltage;  $V_{LED}$  is the total LED forward voltage;  $R_{LX}$  is the switch resistance (0.3 $\Omega$  nominal);  $V_D$  is the diode forward voltage at the required load current.



**Application Information** (continued)

**Diode Selection**

For maximum efficiency and performance, the rectifier (D1) should be a fast low capacitance Schottky diode with low reverse leakage at the maximum operating voltage and temperature. They also provide better efficiency than silicon diodes, due to a combination of lower forward voltage and reduced recovery time.

It is important to select parts with a peak current rating above the peak coil current and a continuous current rating higher than the maximum output load current. It is very important to consider the reverse leakage of the diode when operating above +85°C. Excess leakage will increase the power dissipation in the device and if close to the load may create a thermal runaway condition.

The higher forward voltage and overshoot due to reverse recovery time in silicon diodes will increase the peak voltage on the LX output. If a silicon diode is used, care should be taken to ensure that the total voltage appearing on the LX pin including supply ripple, does not exceed the specified maximum value.

**Ordering Information**

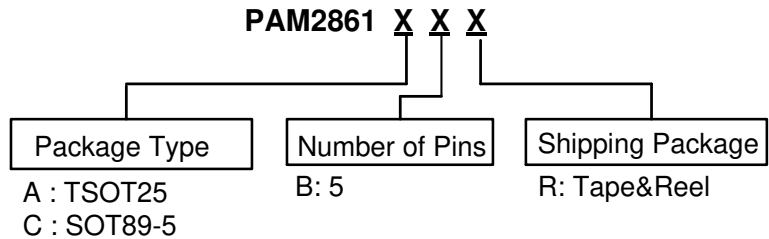

Part Number	Marking Code	Package	Packing	
			Qty.	Carrier
PAM2861ABR	EQXYW	TSOT25	3000 Units	Tape & Reel
PAM2861CBR	P2861 XXXYYW	SOT89-5	1000 Units	Tape & Reel

**Marking Information**

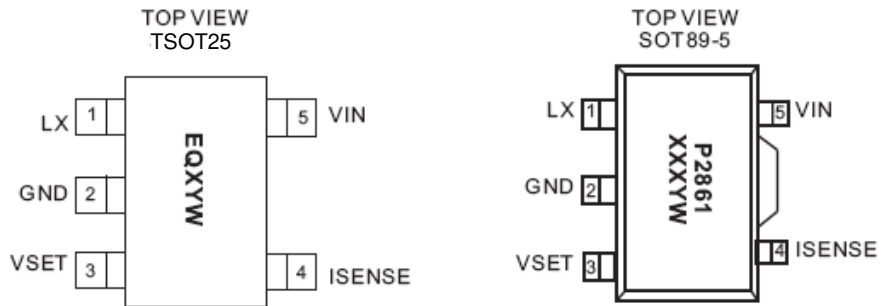

EQ: Product Code of PAM2861  
 X: Internal Code  
 Y: Year  
 W: Week

## Package Outline Dimensions

Please see <http://www.diodes.com/package-outlines.html> for the latest version.

### Package 1: TSOT25

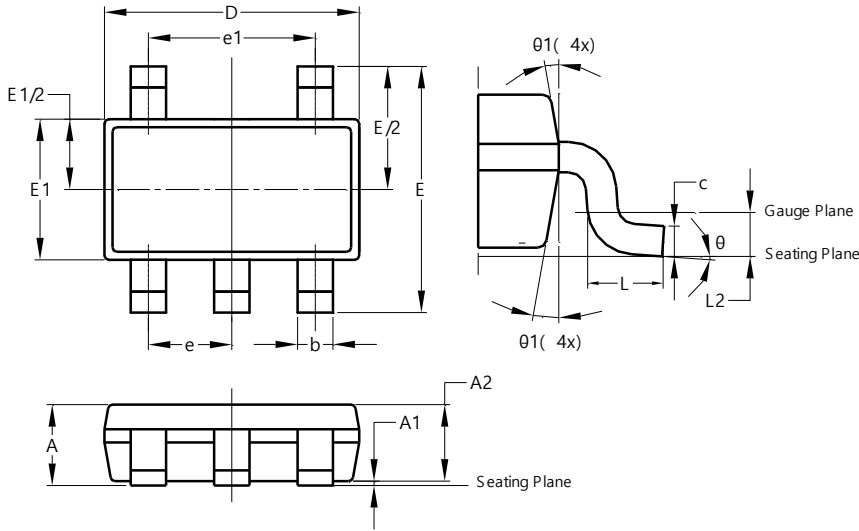

TSOT25			
Dim	Min	Max	Typ
A	-	1.00	-
A1	0.01	0.10	-
A2	0.84	0.90	-
b	0.30	0.45	-
c	0.12	0.20	-
D	-	-	2.90
E	-	-	2.80
E1	-	-	1.60
e	0.95 BSC		
e1	1.90 BSC		
L	0.30	0.50	-
L2	0.25 BSC		
$\theta$	0°	8°	4°
$\theta 1$	4°	12°	-
All Dimensions in mm			

### Package 2: SOT89-5

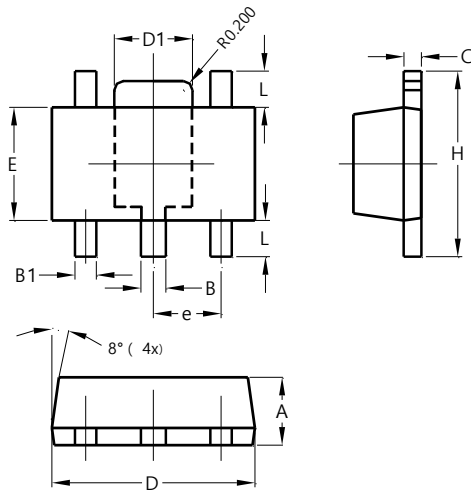

SOT89-5			
Dim	Min	Max	Typ
A	1.40	1.60	1.50
B	0.50	0.62	0.56
B1	0.44	0.54	0.48
C	0.35	0.43	0.38
D	4.40	4.60	4.50
D1	1.62	1.83	1.733
E	2.40	2.60	2.50
e	-	-	1.50
H	3.95	4.25	4.10
L	0.65	0.95	0.80
All Dimensions in mm			

**Suggested Pad Layout**

Please see <http://www.diodes.com/package-outlines.html> for the latest version.

**Package 1: TSOT25**

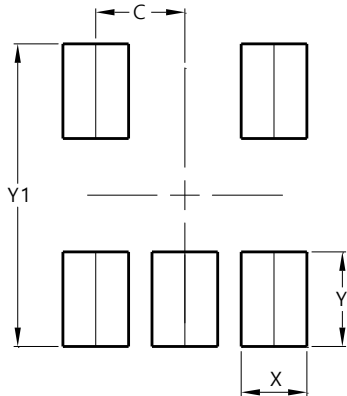

Dimensions	Value (in mm)
C	0.950
X	0.700
Y	1.000
Y1	3.199

**Package 2: SOT89-5**

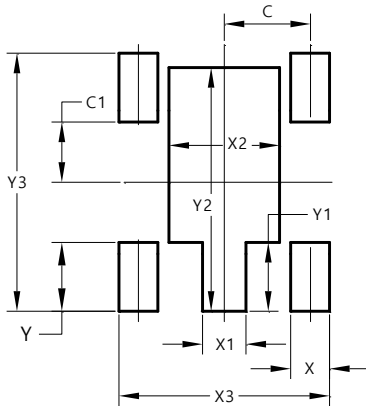

Dimensions	Value (in mm)
C	1.500
C1	1.050
X	0.680
X1	0.760
X2	1.930
X3	3.680
Y	1.200
Y1	1.200
Y2	4.250
Y3	4.500

**Mechanical Data**

**TSOT25 Package**

Moisture Sensitivity: MSL3 per JESD22-A113

Terminals: Finish – Matte Tin Plated Leads, Solderable per M2003 JESD22-B102 **(e3)**

Weight: 0.013 grams (Approximate)

**SOT89-5 Package**

Moisture Sensitivity: MSL3 per JESD22-A113

Terminals: Finish – Matte Tin Plated Leads, Solderable per M2003 JESD22-B102 **(e3)**

Weight: 0.081 grams (Approximate)

**IMPORTANT NOTICE**

1. DIODES INCORPORATED (Diodes) AND ITS SUBSIDIARIES MAKE NO WARRANTY OF ANY KIND, EXPRESS OR IMPLIED, WITH REGARDS TO ANY INFORMATION CONTAINED IN THIS DOCUMENT, INCLUDING, BUT NOT LIMITED TO, THE IMPLIED WARRANTIES OF MERCHANTABILITY, FITNESS FOR A PARTICULAR PURPOSE OR NON-INFRINGEMENT OF THIRD PARTY INTELLECTUAL PROPERTY RIGHTS (AND THEIR EQUIVALENTS UNDER THE LAWS OF ANY JURISDICTION).
2. The Information contained herein is for informational purpose only and is provided only to illustrate the operation of Diodes' products described herein and application examples. Diodes does not assume any liability arising out of the application or use of this document or any product described herein. This document is intended for skilled and technically trained engineering customers and users who design with Diodes' products. Diodes' products may be used to facilitate safety-related applications; however, in all instances customers and users are responsible for (a) selecting the appropriate Diodes products for their applications, (b) evaluating the suitability of Diodes' products for their intended applications, (c) ensuring their applications, which incorporate Diodes' products, comply the applicable legal and regulatory requirements as well as safety and functional-safety related standards, and (d) ensuring they design with appropriate safeguards (including testing, validation, quality control techniques, redundancy, malfunction prevention, and appropriate treatment for aging degradation) to minimize the risks associated with their applications.
3. Diodes assumes no liability for any application-related information, support, assistance or feedback that may be provided by Diodes from time to time. Any customer or user of this document or products described herein will assume all risks and liabilities associated with such use, and will hold Diodes and all companies whose products are represented herein or on Diodes' websites, harmless against all damages and liabilities.
4. Products described herein may be covered by one or more United States, international or foreign patents and pending patent applications. Product names and markings noted herein may also be covered by one or more United States, international or foreign trademarks and trademark applications. Diodes does not convey any license under any of its intellectual property rights or the rights of any third parties (including third parties whose products and services may be described in this document or on Diodes' website) under this document.
5. Diodes' products are provided subject to Diodes' Standard Terms and Conditions of Sale (<https://www.diodes.com/about/company/terms-and-conditions/terms-and-conditions-of-sales/>) or other applicable terms. This document does not alter or expand the applicable warranties provided by Diodes. Diodes does not warrant or accept any liability whatsoever in respect of any products purchased through unauthorized sales channel.
6. Diodes' products and technology may not be used for or incorporated into any products or systems whose manufacture, use or sale is prohibited under any applicable laws and regulations. Should customers or users use Diodes' products in contravention of any applicable laws or regulations, or for any unintended or unauthorized application, customers and users will (a) be solely responsible for any damages, losses or penalties arising in connection therewith or as a result thereof, and (b) indemnify and hold Diodes and its representatives and agents harmless against any and all claims, damages, expenses, and attorney fees arising out of, directly or indirectly, any claim relating to any noncompliance with the applicable laws and regulations, as well as any unintended or unauthorized application.
7. While efforts have been made to ensure the information contained in this document is accurate, complete and current, it may contain technical inaccuracies, omissions and typographical errors. Diodes does not warrant that information contained in this document is error-free and Diodes is under no obligation to update or otherwise correct this information. Notwithstanding the foregoing, Diodes reserves the right to make modifications, enhancements, improvements, corrections or other changes without further notice to this document and any product described herein. This document is written in English but may be translated into multiple languages for reference. Only the English version of this document is the final and determinative format released by Diodes.
8. Any unauthorized copying, modification, distribution, transmission, display or other use of this document (or any portion hereof) is prohibited. Diodes assumes no responsibility for any losses incurred by the customers or users or any third parties arising from any such unauthorized use.
9. This Notice may be periodically updated with the most recent version available at <https://www.diodes.com/about/company/terms-and-conditions/important-notice>

DIODES is a trademark of Diodes Incorporated in the United States and other countries.  
The Diodes logo is a registered trademark of Diodes Incorporated in the United States and other countries.  
© 2022 Diodes Incorporated. All Rights Reserved.

[www.diodes.com](http://www.diodes.com)