

Features

- ◆ 256K x 36, 512K x 18 memory configurations
- ◆ Supports high performance system speed - 150MHz (3.8ns Clock-to-Data Access)
- ◆ ZBT™ Feature - No dead cycles between write and read cycles
- ◆ Internally synchronized output buffer enable eliminates the need to control **OE**
- ◆ Single **R/W** (READ/WRITE) control pin
- ◆ Positive clock-edge triggered address, data, and control signal registers for fully pipelined applications
- ◆ 4-word burst capability (interleaved or linear)
- ◆ Individual byte write (**BW1** - **BW4**) control (May tie active)
- ◆ Three chip enables for simple depth expansion
- ◆ 3.3V power supply ($\pm 5\%$)
- ◆ 3.3V I/O Supply (V_{DDQ})
- ◆ Power down controlled by **ZZ** input
- ◆ Packaged in a JEDEC standard 100-pin plastic thin quad flatpack (TQFP), 119 ball grid array (BGA) and 165 fine pitch ball grid array (fBGA)
- ◆ Industrial temperature range (-40°C to $+85^{\circ}\text{C}$) is available for selected speeds
- ◆ Green parts available, see ordering information

Functional Block Diagram — 256K x 36

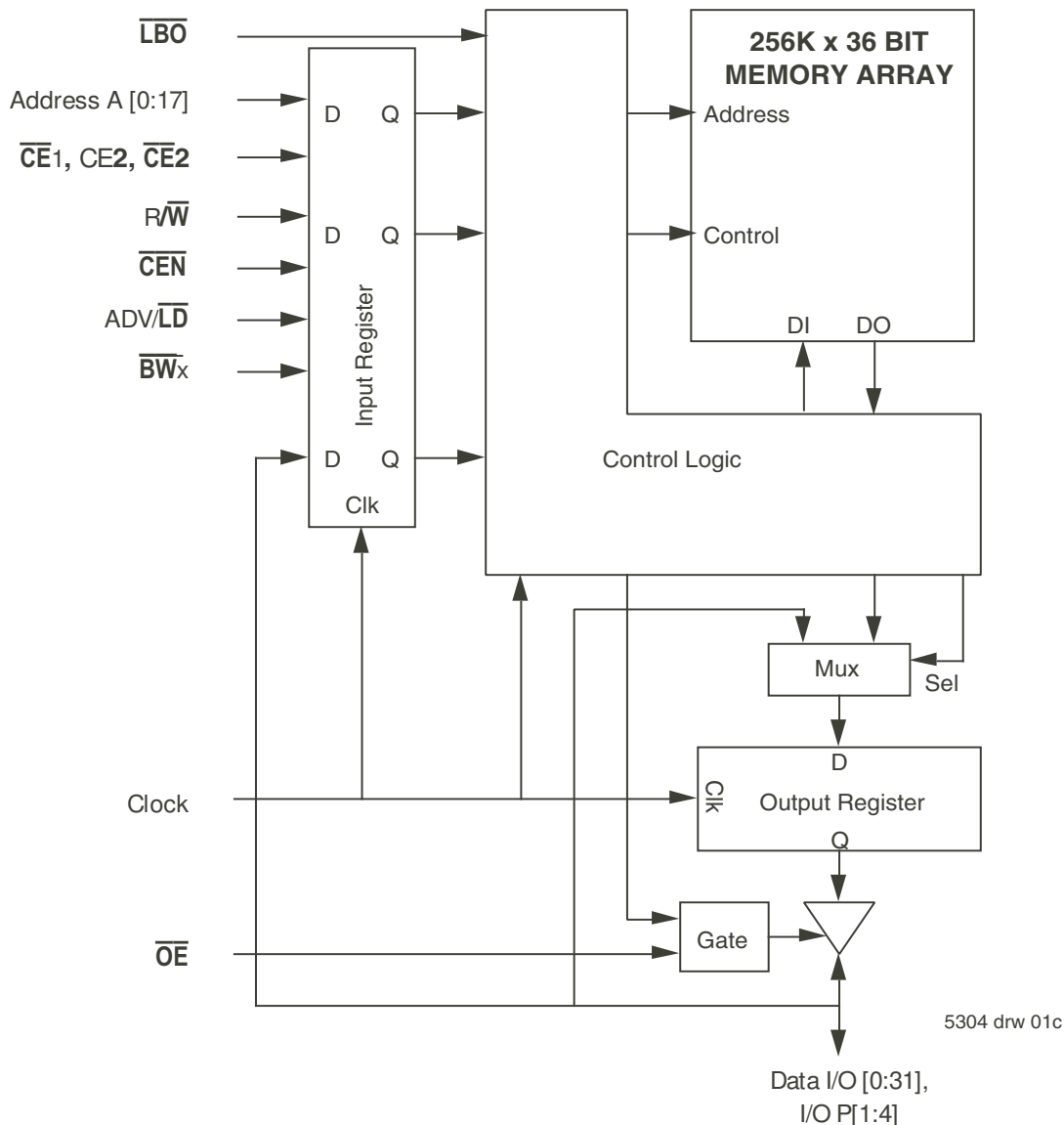

5304 drw 01c

ZBT and Zero Bus Turnaround are trademarks of Renesas Electronics Corporation and the architecture is supported by Micron Technology and Motorola, Inc.

Description

The IDT71V65603/5803 are 3.3V high-speed 9,437,184-bit (9 Megabit) synchronous SRAMs. They are designed to eliminate dead bus cycles when turning the bus around between reads and writes, or writes and reads. Thus, they have been given the name ZBT™, or Zero Bus Turn-around.

Address and control signals are applied to the SRAM during one clock cycle, and two cycles later the associated data cycle occurs, be it read or write.

The IDT71V65603/5803 contain data I/O, address and control signal registers. Output enable is the only asynchronous signal and can be used to disable the outputs at any given time.

A Clock Enable (\overline{CEN}) pin allows operation of the IDT71V65603/5803 to be suspended as long as necessary. All synchronous inputs are ignored when (\overline{CEN}) is high and the internal device registers will hold their previous values.

There are three chip enable pins ($\overline{CE1}$, $CE2$, $\overline{CE2}$) that allow the user to deselect the device when desired. If any one of these three are not asserted

when ADV/\overline{LD} is low, no new memory operation can be initiated. However, any pending data transfers (reads or writes) will be completed. The data bus will tri-state two cycles after chip is deselected or a write is initiated.

The IDT71V65603/5803 have an on-chip burst counter. In the burst mode, the IDT71V65603/5803 can provide four cycles of data for a single address presented to the SRAM. The order of the burst sequence is defined by the \overline{LBO} input pin. The \overline{LBO} pin selects between linear and interleaved burst sequence. The ADV/\overline{LD} signal is used to load a new external address ($ADV/\overline{LD} = \text{LOW}$) or increment the internal burst counter ($ADV/\overline{LD} = \text{HIGH}$).

The IDT71V65603/5803 SRAMs utilize a high-performance CMOS process, and are packaged in a JEDEC Standard 14mm x 20mm 100-pin thin plastic quad flatpack (TQFP) as well as a 119 ball grid array (BGA) and 165 fine pitch ball grid array (fBGA).

Functional Block Diagram — 512K x 18

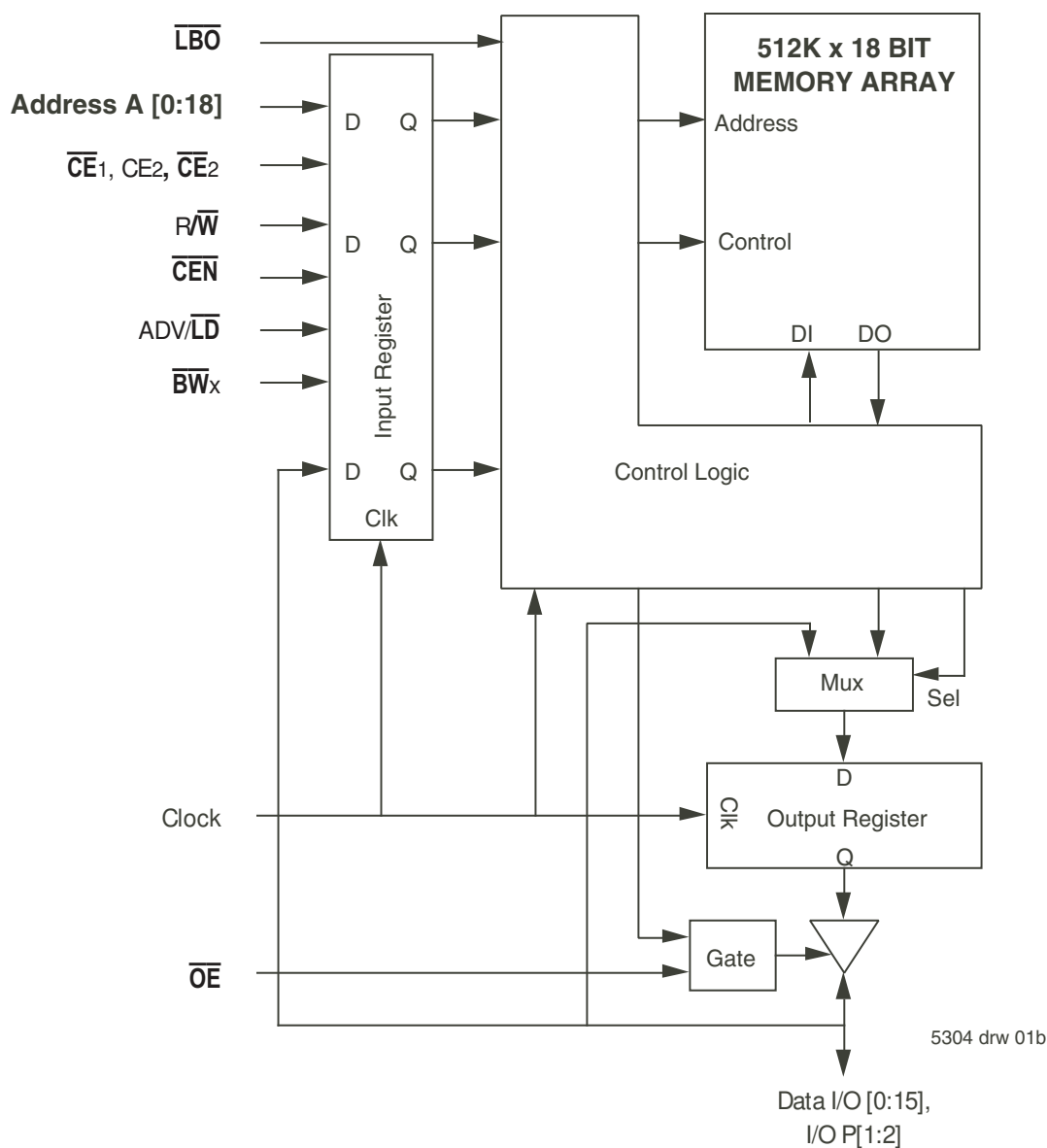

Pin Description Summary

| | | | |
|-------------------------------------------------------------------------------|------------------------------------------|--------|--------------|
| A0-A18 | Address Inputs | Input | Synchronous |
| \overline{CE}_1 , CE ₂ , \overline{CE}_2 | Chip Enables | Input | Synchronous |
| \overline{OE} | Output Enable | Input | Asynchronous |
| R/ \overline{W} | Read/Write Signal | Input | Synchronous |
| \overline{CEN} | Clock Enable | Input | Synchronous |
| \overline{BW}_1 , \overline{BW}_2 , \overline{BW}_3 , \overline{BW}_4 | Individual Byte Write Selects | Input | Synchronous |
| CLK | Clock | Input | N/A |
| ADV/ \overline{LD} | Advance burst address / Load new address | Input | Synchronous |
| \overline{LBO} | Linear / Interleaved Burst Order | Input | Static |
| ZZ | Sleep Mode | Input | Asynchronous |
| I/O0-I/O31, I/OP1-I/OP4 | Data Input / Output | I/O | Synchronous |
| V _{DD} , V _{DDQ} | Core Power, I/O Power | Supply | Static |
| V _{SS} | Ground | Supply | Static |

5304 tbl 01

Pin Definitions⁽¹⁾

| Symbol | Pin Function | I/O | Active | Description |
|---------------------------|-------------------------------|-----|--------|--------------------------------------------------------------------------------------------------------------------------------------------------------------------------------------------------------------------------------------------------------------------------------------------------------------------------------------------------------------------------------------------------------------------------------------------------------------------------------------------------------------|
| A0-A18 | Address Inputs | I | N/A | Synchronous Address inputs. The address register is triggered by a combination of the rising edge of CLK, ADV/LD low, CEN low, and true chip enables. |
| ADV/LD | Advance / Load | I | N/A | ADV/LD is a synchronous input that is used to load the internal registers with new address and control when it is sampled low at the rising edge of clock with the chip selected. When ADV/LD is low with the chip deselected, any burst in progress is terminated. When ADV/LD is sampled high then the internal burst counter is advanced for any burst that was in progress. The external addresses are ignored when ADV/LD is sampled high. |
| R/W | Read / Write | I | N/A | R/W signal is a synchronous input that identifies whether the current load cycle initiated is a Read or Write access to the memory array. The data bus activity for the current cycle takes place two clock cycles later. |
| CEN | Clock Enable | I | LOW | Synchronous Clock Enable Input. When CEN is sampled high, all other synchronous inputs, including clock are ignored and outputs remain unchanged. The effect of CEN sampled high on the device outputs is as if the low to high clock transition did not occur. For normal operation, CEN must be sampled low at rising edge of clock. |
| BW1-BW4 | Individual Byte Write Enables | I | LOW | Synchronous byte write enables. Each 9-bit byte has its own active low byte write enable. On load write cycles (When R/W and ADV/LD are sampled low) the appropriate byte write signal (BW1-BW4) must be valid. The byte write signal must also be valid on each cycle of a burst write. Byte Write signals are ignored when R/W is sampled high. The appropriate byte(s) of data are written into the device two cycles later. BW1-BW4 can all be tied low if always doing write to the entire 36-bit word. |
| CE1, CE2 | Chip Enables | I | LOW | Synchronous active low chip enable. CE1 and CE2 are used with CE2 to enable the IDT71V65603/5803. (CE1 or CE2 sampled high or CE2 sampled low) and ADV/LD low at the rising edge of clock, initiates a deselect cycle. The ZBT™ has a two cycle deselect, i.e., the data bus will tri-state two clock cycles after deselect is initiated. |
| CE2 | Chip Enable | I | HIGH | Synchronous active high chip enable. CE2 is used with CE1 and CE2 to enable the chip. CE2 has inverted polarity but otherwise identical to CE1 and CE2. |
| CLK | Clock | I | N/A | This is the clock input to the IDT71V65603/5803. Except for OE, all timing references for the device are made with respect to the rising edge of CLK. |
| I/O0-I/O31 I/OP1-I/OP4 | Data Input/Output | I/O | N/A | Synchronous data input/output (I/O) pins. Both the data input path and data output path are registered and triggered by the rising edge of CLK. |
| LBO | Linear Burst Order | I | LOW | Burst order selection input. When LBO is high the Interleaved burst sequence is selected. When LBO is low the Linear burst sequence is selected. LBO is a static input and it must not change during device operation. |
| OE | Output Enable | I | LOW | Asynchronous output enable. OE must be low to read data from the 71V65603/5803. When OE is high the I/O pins are in a high-impedance state. OE does not need to be actively controlled for read and write cycles. In normal operation, OE can be tied low. |
| ZZ | Sleep Mode | I | N/A | Asynchronous sleep mode input. ZZ HIGH will gate the CLK internally and power down the 71V65603/5803 to its lowest power consumption level. Data retention is guaranteed in Sleep Mode. |
| VDD | Power Supply | N/A | N/A | 3.3V core power supply. |
| VDDQ | Power Supply | N/A | N/A | 3.3V I/O Supply. |
| VSS | Ground | N/A | N/A | Ground. |

53041b1 02

NOTE:

1. All synchronous inputs must meet specified setup and hold times with respect to CLK.

Pin Configuration - 256K x 36, PKG100⁽³⁾

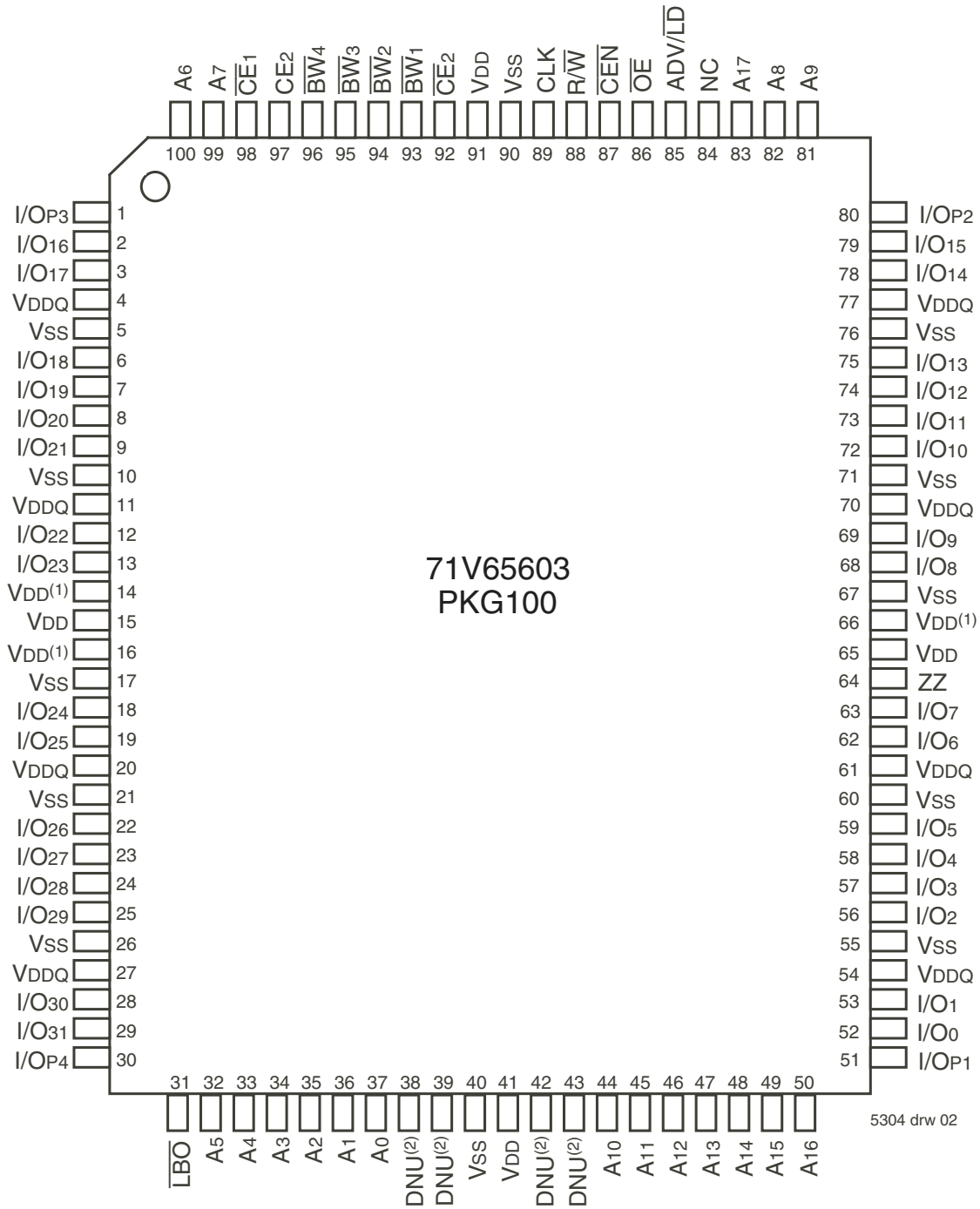

Top View
100 TQFP

NOTES:

1. Pins 14, 16 and 66 do not have to be connected directly to VDD as long as the input voltage is $\geq V_{IH}$.
2. DNU=Do not use. The current die revision allows these pins to be left unconnected, tied LOW (Vss), or tied HIGH (Vdd).
3. This text does not indicate orientation of actual part-marking.

Pin Configuration - 512K x 18, PKG100⁽³⁾

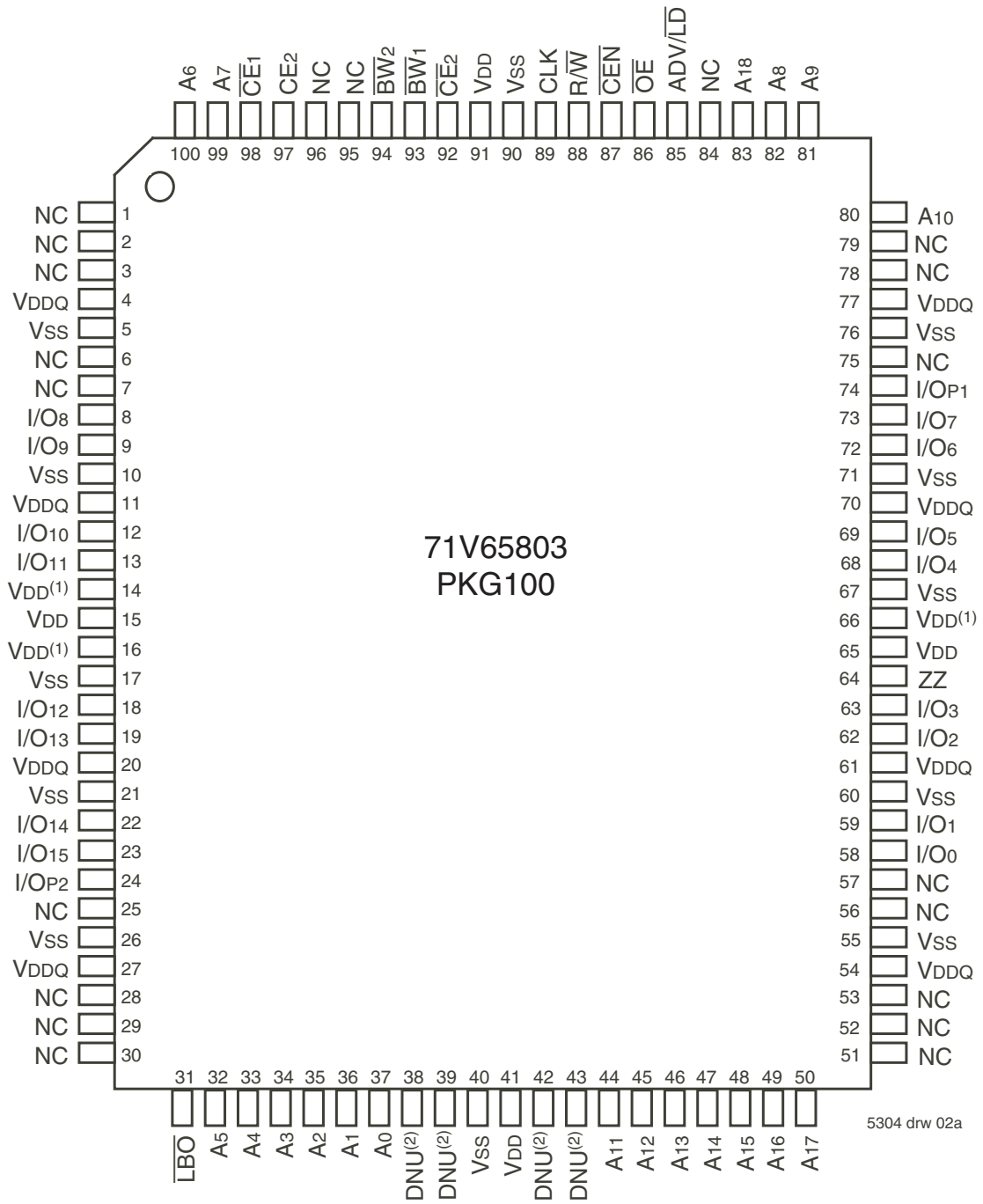

Top View
100 TQFP

NOTES:

1. Pins 14, 16 and 66 do not have to be connected directly to V_{DD} as long as the input voltage is $\geq V_{IH}$.
2. DNU=Do not use. The current die revision allows these pins to be left unconnected, tied LOW (V_{SS}), or tied HIGH (V_{DD}).
3. This text does not indicate orientation of actual part-marking.

Pin Configuration - 256K X 36, BG119, BGG119⁽³⁾

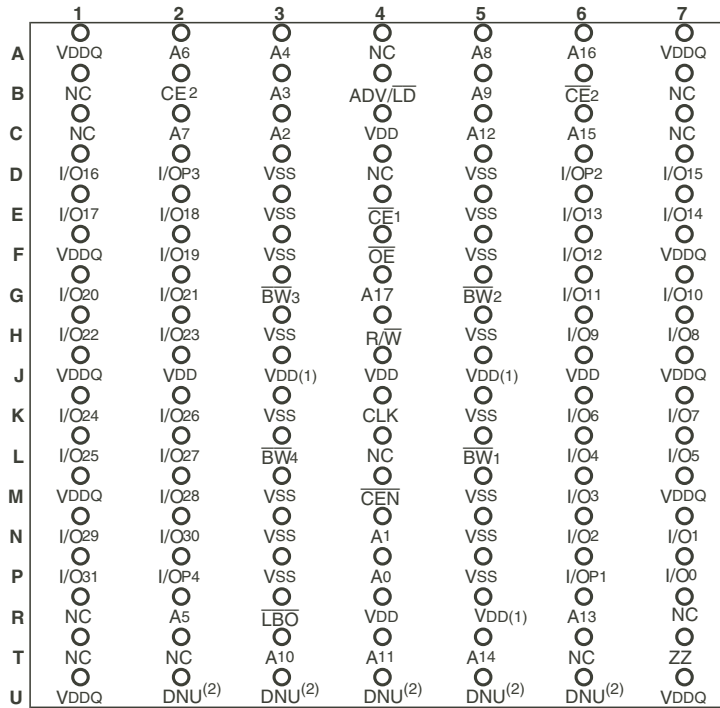

5304 drw 13a

Top View

Pin Configuration - 512K X 18, BG119, BGG119⁽³⁾

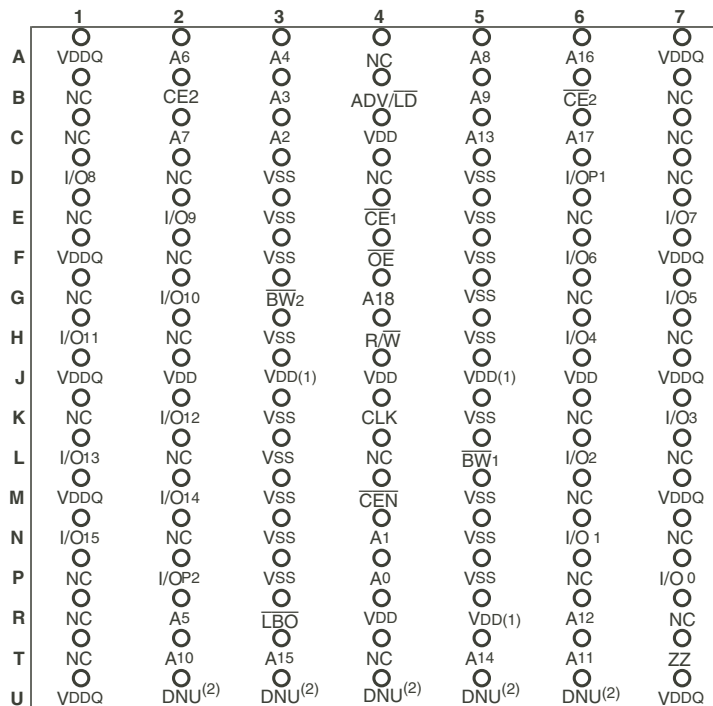

5304 drw 13b

Top View

NOTES:

- J3, J5, and R5 do not have to be directly connected to V_{DD} as long as the input voltage is ≥ V_{IH}.
- DNU = Do not use. The current die revision allows these pins to be left unconnected, tied LOW (V_{SS}), or tied HIGH (V_{DD}).
- This text does not indicate orientation of actual part-marking.

Pin Configuration - 256K X 36, BQ165, BQG165⁽³⁾

| | 1 | 2 | 3 | 4 | 5 | 6 | 7 | 8 | 9 | 10 | 11 |
|---|--------------------|--------------------|-------------------|-------------------|--------------------|-------------------|--------------------|----------------------|------|-------|-------|
| A | NC | A7 | \overline{CE}_1 | \overline{BW}_3 | \overline{BW}_2 | \overline{CE}_2 | \overline{CEN} | ADV/ \overline{LD} | A17 | A8 | NC |
| B | NC | A6 | CE2 | \overline{BW}_4 | \overline{BW}_1 | CLK | R/ \overline{W} | \overline{OE} | NC | A9 | NC |
| C | I/OP3 | NC | VDDQ | VSS | VSS | VSS | VSS | VSS | VDDQ | NC | I/OP2 |
| D | I/O17 | I/O16 | VDDQ | VDD | VSS | VSS | VSS | VDD | VDDQ | I/O15 | I/O14 |
| E | I/O19 | I/O18 | VDDQ | VDD | VSS | VSS | VSS | VDD | VDDQ | I/O13 | I/O12 |
| F | I/O21 | I/O20 | VDDQ | VDD | VSS | VSS | VSS | VDD | VDDQ | I/O11 | I/O10 |
| G | I/O ₂₃ | I/O22 | VDDQ | VDD | VSS | VSS | VSS | VDD | VDDQ | I/O9 | I/O8 |
| H | VDD ⁽¹⁾ | VDD ⁽¹⁾ | NC | VDD | VSS | VSS | VSS | VDD | NC | NC | ZZ |
| J | I/O25 | I/O24 | VDDQ | VDD | VSS | VSS | VSS | VDD | VDDQ | I/O7 | I/O6 |
| K | I/O27 | I/O26 | VDDQ | VDD | VSS | VSS | VSS | VDD | VDDQ | I/O5 | I/O4 |
| L | I/O29 | I/O28 | VDDQ | VDD | VSS | VSS | VSS | VDD | VDDQ | I/O3 | I/O2 |
| M | I/O31 | I/O30 | VDDQ | VDD | VSS | VSS | VSS | VDD | VDDQ | I/O1 | I/O0 |
| N | I/OP4 | NC | VDDQ | VSS | DNU ⁽²⁾ | NC | VDD ⁽¹⁾ | VSS | VDDQ | NC | I/OP1 |
| P | NC | NC | A5 | A2 | DNU ⁽²⁾ | A1 | DNU ⁽²⁾ | A10 | A13 | A14 | NC |
| R | $\overline{LB0}$ | NC | A4 | A3 | DNU ⁽²⁾ | A0 | DNU ⁽²⁾ | A11 | A12 | A15 | A16 |

5304 tbl 25a

Pin Configuration - 512K X 18, BQ165, BQG165⁽³⁾

| | 1 | 2 | 3 | 4 | 5 | 6 | 7 | 8 | 9 | 10 | 11 |
|---|--------------------|--------------------|-------------------|-------------------|--------------------|-------------------|--------------------|----------------------|------|------|-------|
| A | NC | A7 | \overline{CE}_1 | \overline{BW}_2 | NC | \overline{CE}_2 | \overline{CEN} | ADV/ \overline{LD} | A18 | A8 | A10 |
| B | NC | A6 | CE2 | NC | \overline{BW}_1 | CLK | R/ \overline{W} | \overline{OE} | NC | A9 | NC |
| C | NC | NC | VDDQ | VSS | VSS | VSS | VSS | VSS | VDDQ | NC | I/OP1 |
| D | NC | I/O8 | VDDQ | VDD | VSS | VSS | VSS | VDD | VDDQ | NC | I/O7 |
| E | NC | I/O9 | VDDQ | VDD | VSS | VSS | VSS | VDD | VDDQ | NC | I/O6 |
| F | NC | I/O10 | VDDQ | VDD | VSS | VSS | VSS | VDD | VDDQ | NC | I/O5 |
| G | NC | I/O11 | VDDQ | VDD | VSS | VSS | VSS | VDD | VDDQ | NC | I/O4 |
| H | VDD ⁽¹⁾ | VDD ⁽¹⁾ | NC | VDD | VSS | VSS | VSS | VDD | NC | NC | ZZ |
| J | I/O12 | NC | VDDQ | VDD | VSS | VSS | VSS | VDD | VDDQ | I/O3 | NC |
| K | I/O13 | NC | VDDQ | VDD | VSS | VSS | VSS | VDD | VDDQ | I/O2 | NC |
| L | I/O14 | NC | VDDQ | VDD | VSS | VSS | VSS | VDD | VDDQ | I/O1 | NC |
| M | I/O15 | NC | VDDQ | VDD | VSS | VSS | VSS | VDD | VDDQ | I/O0 | NC |
| N | I/OP2 | NC | VDDQ | VSS | DNU ⁽²⁾ | NC | VDD ⁽¹⁾ | VSS | VDDQ | NC | NC |
| P | NC | NC | A5 | A2 | DNU ⁽²⁾ | A1 | DNU ⁽²⁾ | A11 | A14 | A15 | NC |
| R | $\overline{LB0}$ | NC | A4 | A3 | DNU ⁽²⁾ | A0 | DNU ⁽²⁾ | A12 | A13 | A16 | A17 |

5304 tbl25b

NOTES:

1. H1, H2, and N7 do not have to be directly connected to VDD as long as the input voltage is $\geq V_{IH}$.
2. DNU=Do not use. The current die revision allows these pins to be left unconnected, tied LOW (Vss), or tied HIGH (VDD).
3. This text does not indicate orientation of actual part-marking.

Absolute Maximum Ratings⁽¹⁾

| Symbol | Rating | Commercial & Industrial | Unit |
|------------------------------------|--------------------------------------|-------------------------------|------|
| V _{TERM} ⁽²⁾ | Terminal Voltage with Respect to GND | -0.5 to +4.6 | V |
| V _{TERM} ^(3,6) | Terminal Voltage with Respect to GND | -0.5 to V _{DD} | V |
| V _{TERM} ^(4,6) | Terminal Voltage with Respect to GND | -0.5 to V _{DD} +0.5 | V |
| V _{TERM} ^(5,6) | Terminal Voltage with Respect to GND | -0.5 to V _{DDQ} +0.5 | V |
| T _A ⁽⁷⁾ | Commercial Operating Temperature | -0 to +70 | °C |
| | Industrial Operating Temperature | -40 to +85 | °C |
| T _{BIAS} | Temperature Under Bias | -55 to +125 | °C |
| T _{STG} | Storage Temperature | -55 to +125 | °C |
| P _T | Power Dissipation | 2.0 | W |
| I _{OUT} | DC Output Current | 50 | mA |

NOTES:

5304 tbl 06

- Stresses greater than those listed under ABSOLUTE MAXIMUM RATINGS may cause permanent damage to the device. This is a stress rating only and functional operation of the device at these or any other conditions above those indicated in the operational sections of this specification is not implied. Exposure to absolute maximum rating conditions for extended periods may affect reliability.
- V_{DD} terminals only.
- V_{DDQ} terminals only.
- Input terminals only.
- I/O terminals only.
- This is a steady-state DC parameter that applies after the power supply has reached its nominal operating value. Power sequencing is not necessary; however, the voltage on any input or I/O pin cannot exceed V_{DDQ} during power supply ramp up.
- During production testing, the case temperature equals T_A.

Recommended Operating Temperature and Supply Voltage

| Grade | Ambient Temperature ⁽¹⁾ | V _{SS} | V _{DD} | V _{DDQ} |
|------------|------------------------------------|-----------------|-----------------|------------------|
| Commercial | 0° C to +70° C | 0V | 3.3V±5% | 3.3V±5% |
| Industrial | -40° C to +85° C | 0V | 3.3V±5% | 3.3V±5% |

NOTE:

5304 tbl 05

- During production testing, the case temperature equals the ambient temperature.

Recommended DC Operating Conditions

| Symbol | Parameter | Min. | Typ. | Max. | Unit |
|------------------|-----------------------------|---------------------|------|-----------------------|------|
| V _{DD} | Core Supply Voltage | 3.135 | 3.3 | 3.465 | V |
| V _{DDQ} | I/O Supply Voltage | 3.135 | 3.3 | 3.465 | V |
| V _{SS} | Supply Voltage | 0 | 0 | 0 | V |
| V _{IH} | Input High Voltage - Inputs | 2.0 | — | V _{DD} +0.3 | V |
| V _{IH} | Input High Voltage - I/O | 2.0 | — | V _{DDQ} +0.3 | V |
| V _{IL} | Input Low Voltage | -0.3 ⁽¹⁾ | — | 0.8 | V |

NOTE:

5304 tbl 04

- V_{IL} (min.) = -1.0V for pulse width less than t_{ovc}/2, once per cycle.

165 fBGA Capacitance⁽¹⁾

(T_A = +25° C, f = 1.0MHz)

| Symbol | Parameter ⁽¹⁾ | Conditions | Max. | Unit |
|------------------|--------------------------|------------------------|------|------|
| C _{IN} | Input Capacitance | V _{IN} = 3dV | TBD | pF |
| C _{I/O} | I/O Capacitance | V _{OUT} = 3dV | TBD | pF |

5304 tbl 07b

100 TQFP Capacitance⁽¹⁾

(T_A = +25° C, f = 1.0MHz)

| Symbol | Parameter ⁽¹⁾ | Conditions | Max. | Unit |
|------------------|--------------------------|------------------------|------|------|
| C _{IN} | Input Capacitance | V _{IN} = 3dV | 5 | pF |
| C _{I/O} | I/O Capacitance | V _{OUT} = 3dV | 7 | pF |

5304 tbl 07

119 BGA Capacitance⁽¹⁾

(T_A = +25° C, f = 1.0MHz)

| Symbol | Parameter ⁽¹⁾ | Conditions | Max. | Unit |
|------------------|--------------------------|------------------------|------|------|
| C _{IN} | Input Capacitance | V _{IN} = 3dV | 7 | pF |
| C _{I/O} | I/O Capacitance | V _{OUT} = 3dV | 7 | pF |

5304 tbl 07a

NOTE:

- This parameter is guaranteed by device characterization, but not production tested.

Synchronous Truth Table⁽¹⁾

| \overline{CEN} | R/\overline{W} | Chip ⁽⁵⁾ Enable | ADV/\overline{LD} | \overline{BW}_x | ADDRESS USED | PREVIOUS CYCLE | CURRENT CYCLE | I/O (2 cycles later) |
|------------------|------------------|-------------------------------|---------------------|-------------------|-----------------|-----------------------------|-------------------------------------------------------|-------------------------|
| L | L | Select | L | Valid | External | X | LOAD WRITE | D ⁽⁷⁾ |
| L | H | Select | L | X | External | X | LOAD READ | Q ⁽⁷⁾ |
| L | X | X | H | Valid | Internal | LOAD WRITE / BURST WRITE | BURST WRITE (Advance burst counter) ⁽²⁾ | D ⁽⁷⁾ |
| L | X | X | H | X | Internal | LOAD READ / BURST READ | BURST READ (Advance burst counter) ⁽²⁾ | Q ⁽⁷⁾ |
| L | X | Deselect | L | X | X | X | DESELECT or STOP ⁽³⁾ | HiZ |
| L | X | X | H | X | X | DESELECT / NOOP | NOOP | HiZ |
| H | X | X | X | X | X | X | SUSPEND ⁽⁴⁾ | Previous Value |

5304 tbl 08

NOTES:

- L = V_{IL}, H = V_{IH}, X = Don't Care.
- When ADV/\overline{LD} signal is sampled high, the internal burst counter is incremented. The R/\overline{W} signal is ignored when the counter is advanced. Therefore the nature of the burst cycle (Read or Write) is determined by the status of the R/\overline{W} signal when the first address is loaded at the beginning of the burst cycle.
- Deselect cycle is initiated when either (\overline{CE}_1 , or \overline{CE}_2 is sampled high or CE_2 is sampled low) and ADV/\overline{LD} is sampled low at rising edge of clock. The data bus will tri-state two cycles after deselect is initiated.
- When \overline{CEN} is sampled high at the rising edge of clock, that clock edge is blocked from propagating through the part. The state of all the internal registers and the I/Os remains unchanged.
- To select the chip requires $\overline{CE}_1 = L$, $\overline{CE}_2 = L$, $CE_2 = H$ on these chip enables. Chip is deselected if any one of the chip enables is false.
- Device Outputs are ensured to be in High-Z after the first rising edge of clock upon power-up.
- Q - Data read from the device, D - data written to the device.

Partial Truth Table for Writes⁽¹⁾

| OPERATION | R/\overline{W} | \overline{BW}_1 | \overline{BW}_2 | \overline{BW}_3 ⁽³⁾ | \overline{BW}_4 ⁽³⁾ |
|---------------------------------------------------|------------------|-------------------|-------------------|----------------------------------|----------------------------------|
| READ | H | X | X | X | X |
| WRITE ALL BYTES | L | L | L | L | L |
| WRITE BYTE 1 (I/O[0:7], I/OP1) ⁽²⁾ | L | L | H | H | H |
| WRITE BYTE 2 (I/O[8:15], I/OP2) ⁽²⁾ | L | H | L | H | H |
| WRITE BYTE 3 (I/O[16:23], I/OP3) ^(2,3) | L | H | H | L | H |
| WRITE BYTE 4 (I/O[24:31], I/OP4) ^(2,3) | L | H | H | H | L |
| NO WRITE | L | H | H | H | H |

5304 tbl 09

NOTES:

- L = V_{IL}, H = V_{IH}, X = Don't Care.
- Multiple bytes may be selected during the same cycle.
- N/A for X18 configuration.

Interleaved Burst Sequence Table ($\overline{\text{LBO}} = \text{VDD}$)

| | Sequence 1 | | Sequence 2 | | Sequence 3 | | Sequence 4 | |
|-------------------------------|------------|----|------------|----|------------|----|------------|----|
| | A1 | A0 | A1 | A0 | A1 | A0 | A1 | A0 |
| First Address | 0 | 0 | 0 | 1 | 1 | 0 | 1 | 1 |
| Second Address | 0 | 1 | 0 | 0 | 1 | 1 | 1 | 0 |
| Third Address | 1 | 0 | 1 | 1 | 0 | 0 | 0 | 1 |
| Fourth Address ⁽¹⁾ | 1 | 1 | 1 | 0 | 0 | 1 | 0 | 0 |

5304 tbl 10

NOTE:

1. Upon completion of the Burst sequence the counter wraps around to its initial state and continues counting.

Linear Burst Sequence Table ($\overline{\text{LBO}} = \text{Vss}$)

| | Sequence 1 | | Sequence 2 | | Sequence 3 | | Sequence 4 | |
|-------------------------------|------------|----|------------|----|------------|----|------------|----|
| | A1 | A0 | A1 | A0 | A1 | A0 | A1 | A0 |
| First Address | 0 | 0 | 0 | 1 | 1 | 0 | 1 | 1 |
| Second Address | 0 | 1 | 1 | 0 | 1 | 1 | 0 | 0 |
| Third Address | 1 | 0 | 1 | 1 | 0 | 0 | 0 | 1 |
| Fourth Address ⁽¹⁾ | 1 | 1 | 0 | 0 | 0 | 1 | 1 | 0 |

5304 tbl 11

NOTE:

1. Upon completion of the Burst sequence the counter wraps around to its initial state and continues counting.

Functional Timing Diagram⁽¹⁾

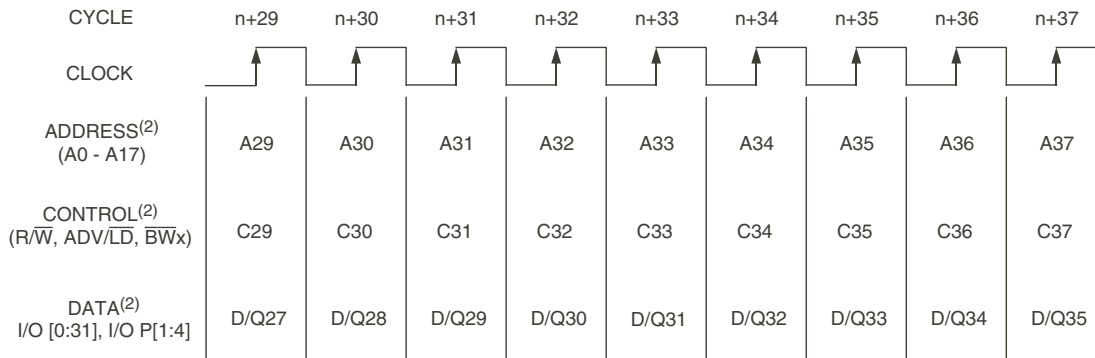

5304 drw 03

NOTES:

1. This assumes $\overline{\text{CEN}}$, $\overline{\text{CE}}_1$, CE_2 , $\overline{\text{CE}}_2$ are all true.
2. All Address, Control and Data_In are only required to meet set-up and hold time with respect to the rising edge of clock. Data_Out is valid after a clock-to-data delay from the rising edge of clock.

Device Operation - Showing Mixed Load, Burst, Deselect and NOOP Cycles⁽²⁾

| Cycle | Address | R \bar{W} | ADV/ \bar{LD} | $\bar{CE}^{(1)}$ | \bar{CEN} | \bar{BW}_x | \bar{OE} | I/O | Comments |
|-------|----------------|-------------|-----------------|------------------|-------------|--------------|------------|------------------|------------------|
| n | A ₀ | H | L | L | L | X | X | X | Load read |
| n+1 | X | X | H | X | L | X | X | X | Burst read |
| n+2 | A ₁ | H | L | L | L | X | L | Q ₀ | Load read |
| n+3 | X | X | L | H | L | X | L | Q ₀₊₁ | Deselect or STOP |
| n+4 | X | X | H | X | L | X | L | Q ₁ | NOOP |
| n+5 | A ₂ | H | L | L | L | X | X | Z | Load read |
| n+6 | X | X | H | X | L | X | X | Z | Burst read |
| n+7 | X | X | L | H | L | X | L | Q ₂ | Deselect or STOP |
| n+8 | A ₃ | L | L | L | L | L | L | Q ₂₊₁ | Load write |
| n+9 | X | X | H | X | L | L | X | Z | Burst write |
| n+10 | A ₄ | L | L | L | L | L | X | D ₃ | Load write |
| n+11 | X | X | L | H | L | X | X | D ₃₊₁ | Deselect or STOP |
| n+12 | X | X | H | X | L | X | X | D ₄ | NOOP |
| n+13 | A ₅ | L | L | L | L | L | X | Z | Load write |
| n+14 | A ₆ | H | L | L | L | X | X | Z | Load read |
| n+15 | A ₇ | L | L | L | L | L | X | D ₅ | Load write |
| n+16 | X | X | H | X | L | L | L | Q ₆ | Burst write |
| n+17 | A ₈ | H | L | L | L | X | X | D ₇ | Load read |
| n+18 | X | X | H | X | L | X | X | D ₇₊₁ | Burst read |
| n+19 | A ₉ | L | L | L | L | L | L | Q ₈ | Load write |

5304tbl 12

NOTES:

- $\bar{CE} = L$ is defined as $\bar{CE}_1 = L$, $\bar{CE}_2 = L$ and $CE_2 = H$. $\bar{CE} = H$ is defined as $\bar{CE}_1 = H$, $\bar{CE}_2 = H$ or $CE_2 = L$.
- H = High; L = Low; X = Don't Care; Z = High Impedance.

Read Operation⁽¹⁾

| Cycle | Address | R \bar{W} | ADV/ \bar{LD} | $\bar{CE}^{(2)}$ | \bar{CEN} | \bar{BW}_x | \bar{OE} | I/O | Comments |
|-------|----------------|-------------|-----------------|------------------|-------------|--------------|------------|----------------|---------------------------------------------|
| n | A ₀ | H | L | L | L | X | X | X | Address and Control meet setup |
| n+1 | X | X | X | X | L | X | X | X | Clock Setup Valid |
| n+2 | X | X | X | X | X | X | L | Q ₀ | Contents of Address A ₀ Read Out |

5304 tbl 13

NOTES:

- H = High; L = Low; X = Don't Care; Z = High Impedance.
- $\bar{CE} = L$ is defined as $\bar{CE}_1 = L$, $\bar{CE}_2 = L$ and $CE_2 = H$. $\bar{CE} = H$ is defined as $\bar{CE}_1 = H$, $\bar{CE}_2 = H$ or $CE_2 = L$.

Burst Read Operation⁽¹⁾

| Cycle | Address | R \bar{W} | ADV/ \bar{LD} | $\bar{CE}^{(2)}$ | \bar{CEN} | \bar{BW}_x | \bar{OE} | I/O | Comments |
|-------|----------------|-------------|-----------------|------------------|-------------|--------------|------------|------------------|--------------------------------------------------------|
| n | A ₀ | H | L | L | L | X | X | X | Address and Control meet setup |
| n+1 | X | X | H | X | L | X | X | X | Clock Setup Valid, Advance Counter |
| n+2 | X | X | H | X | L | X | L | Q ₀ | Address A ₀ Read Out, Inc. Count |
| n+3 | X | X | H | X | L | X | L | Q ₀₊₁ | Address A ₀₊₁ Read Out, Inc. Count |
| n+4 | X | X | H | X | L | X | L | Q ₀₊₂ | Address A ₀₊₂ Read Out, Inc. Count |
| n+5 | A ₁ | H | L | L | L | X | L | Q ₀₊₃ | Address A ₀₊₃ Read Out, Load A ₁ |
| n+6 | X | X | H | X | L | X | L | Q ₀ | Address A ₀ Read Out, Inc. Count |
| n+7 | X | X | H | X | L | X | L | Q ₁ | Address A ₁ Read Out, Inc. Count |
| n+8 | A ₂ | H | L | L | L | X | L | Q ₁₊₁ | Address A ₁₊₁ Read Out, Load A ₂ |

5304 tbl 14

NOTES:

1. H = High; L = Low; X = Don't Care; Z = High Impedance..
2. $\bar{CE} = L$ is defined as $\bar{CE}_1 = L$, $\bar{CE}_2 = L$ and $CE_2 = H$. $\bar{CE} = H$ is defined as $\bar{CE}_1 = H$, $\bar{CE}_2 = H$ or $CE_2 = L$.

Write Operation⁽¹⁾

| Cycle | Address | R \bar{W} | ADV/ \bar{LD} | $\bar{CE}^{(2)}$ | \bar{CEN} | \bar{BW}_x | \bar{OE} | I/O | Comments |
|-------|----------------|-------------|-----------------|------------------|-------------|--------------|------------|----------------|---------------------------------|
| n | A ₀ | L | L | L | L | L | X | X | Address and Control meet setup |
| n+1 | X | X | X | X | L | X | X | X | Clock Setup Valid |
| n+2 | X | X | X | X | L | X | X | D ₀ | Write to Address A ₀ |

5304 tbl 15

NOTES:

1. H = High; L = Low; X = Don't Care; Z = High Impedance.
2. $\bar{CE} = L$ is defined as $\bar{CE}_1 = L$, $\bar{CE}_2 = L$ and $CE_2 = H$. $\bar{CE} = H$ is defined as $\bar{CE}_1 = H$, $\bar{CE}_2 = H$ or $CE_2 = L$.

Burst Write Operation⁽¹⁾

| Cycle | Address | R \bar{W} | ADV/ \bar{LD} | $\bar{CE}^{(2)}$ | \bar{CEN} | \bar{BW}_x | \bar{OE} | I/O | Comments |
|-------|----------------|-------------|-----------------|------------------|-------------|--------------|------------|------------------|-----------------------------------------------------|
| n | A ₀ | L | L | L | L | L | X | X | Address and Control meet setup |
| n+1 | X | X | H | X | L | L | X | X | Clock Setup Valid, Inc. Count |
| n+2 | X | X | H | X | L | L | X | D ₀ | Address A ₀ Write, Inc. Count |
| n+3 | X | X | H | X | L | L | X | D ₀₊₁ | Address A ₀₊₁ Write, Inc. Count |
| n+4 | X | X | H | X | L | L | X | D ₀₊₂ | Address A ₀₊₂ Write, Inc. Count |
| n+5 | A ₁ | L | L | L | L | L | X | D ₀₊₃ | Address A ₀₊₃ Write, Load A ₁ |
| n+6 | X | X | H | X | L | L | X | D ₀ | Address A ₀ Write, Inc. Count |
| n+7 | X | X | H | X | L | L | X | D ₁ | Address A ₁ Write, Inc. Count |
| n+8 | A ₂ | L | L | L | L | L | X | D ₁₊₁ | Address A ₁₊₁ Write, Load A ₂ |

5304 tbl 16

NOTES:

1. H = High; L = Low; X = Don't Care; ? = Don't Know; Z = High Impedance.
2. $\bar{CE} = L$ is defined as $\bar{CE}_1 = L$, $\bar{CE}_2 = L$ and $CE_2 = H$. $\bar{CE} = H$ is defined as $\bar{CE}_1 = H$, $\bar{CE}_2 = H$ or $CE_2 = L$.

Read Operation with Clock Enable Used⁽¹⁾

| Cycle | Address | R \bar{W} | ADV/ \bar{LD} | $\bar{CE}^{(2)}$ | \bar{CEN} | \bar{BW}_x | \bar{OE} | I/O | Comments |
|-------|----------------|-------------|-----------------|------------------|-------------|--------------|------------|----------------|---------------------------------------------------|
| n | A ₀ | H | L | L | L | X | X | X | Address and Control meet setup |
| n+1 | X | X | X | X | H | X | X | X | Clock n+1 Ignored |
| n+2 | A ₁ | H | L | L | L | X | X | X | Clock Valid |
| n+3 | X | X | X | X | H | X | L | Q ₀ | Clock Ignored, Data Q ₀ is on the bus. |
| n+4 | X | X | X | X | H | X | L | Q ₀ | Clock Ignored, Data Q ₀ is on the bus. |
| n+5 | A ₂ | H | L | L | L | X | L | Q ₀ | Address A ₀ Read out (bus trans.) |
| n+6 | A ₃ | H | L | L | L | X | L | Q ₁ | Address A ₁ Read out (bus trans.) |
| n+7 | A ₄ | H | L | L | L | X | L | Q ₂ | Address A ₂ Read out (bus trans.) |

5304 tbl 17

NOTES:

1. H = High; L = Low; X = Don't Care; Z = High Impedance.
2. $\bar{CE} = L$ is defined as $\bar{CE}_1 = L$, $\bar{CE}_2 = L$ and $CE_2 = H$. $\bar{CE} = H$ is defined as $\bar{CE}_1 = H$, $\bar{CE}_2 = H$ or $CE_2 = L$.

Write Operation with Clock Enable Used⁽¹⁾

| Cycle | Address | R \bar{W} | ADV/ \bar{LD} | $\bar{CE}^{(2)}$ | \bar{CEN} | \bar{BW}_x | \bar{OE} | I/O | Comments |
|-------|----------------|-------------|-----------------|------------------|-------------|--------------|------------|----------------|---------------------------------|
| n | A ₀ | L | L | L | L | L | X | X | Address and Control meet setup. |
| n+1 | X | X | X | X | H | X | X | X | Clock n+1 Ignored. |
| n+2 | A ₁ | L | L | L | L | L | X | X | Clock Valid. |
| n+3 | X | X | X | X | H | X | X | X | Clock Ignored. |
| n+4 | X | X | X | X | H | X | X | X | Clock Ignored. |
| n+5 | A ₂ | L | L | L | L | L | X | D ₀ | Write Data D ₀ |
| n+6 | A ₃ | L | L | L | L | L | X | D ₁ | Write Data D ₁ |
| n+7 | A ₄ | L | L | L | L | L | X | D ₂ | Write Data D ₂ |

5304 tbl 18

NOTES:

1. H = High; L = Low; X = Don't Care; Z = High Impedance.
2. $\bar{CE} = L$ is defined as $\bar{CE}_1 = L$, $\bar{CE}_2 = L$ and $CE_2 = H$. $\bar{CE} = H$ is defined as $\bar{CE}_1 = H$, $\bar{CE}_2 = H$ or $CE_2 = L$.

Read Operation with Chip Enable Used⁽¹⁾

| Cycle | Address | R \overline{W} | ADV/ \overline{LD} | $\overline{CE}^{(2)}$ | \overline{CEN} | \overline{BW}_x | \overline{OE} | I/O ⁽³⁾ | Comments |
|-------|----------------|------------------|----------------------|-----------------------|------------------|-------------------|-----------------|--------------------|--------------------------------------------------------|
| n | X | X | L | H | L | X | X | ? | Deselected. |
| n+1 | X | X | L | H | L | X | X | ? | Deselected. |
| n+2 | A ₀ | H | L | L | L | X | X | Z | Address and Control meet setup |
| n+3 | X | X | L | H | L | X | X | Z | Deselected or STOP. |
| n+4 | A ₁ | H | L | L | L | X | L | Q ₀ | Address A ₀ Read out. Load A ₁ . |
| n+5 | X | X | L | H | L | X | X | Z | Deselected or STOP. |
| n+6 | X | X | L | H | L | X | L | Q ₁ | Address A ₁ Read out. Deselected. |
| n+7 | A ₂ | H | L | L | L | X | X | Z | Address and control meet setup. |
| n+8 | X | X | L | H | L | X | X | Z | Deselected or STOP. |
| n+9 | X | X | L | H | L | X | L | Q ₂ | Address A ₂ Read out. Deselected. |

5304 tbl 19

NOTES:

1. H = High; L = Low; X = Don't Care; ? = Don't Know; Z = High Impedance.
2. $\overline{CE} = L$ is defined as $\overline{CE}_1 = L$, $\overline{CE}_2 = L$ and $CE_2 = H$. $\overline{CE} = H$ is defined as $\overline{CE}_1 = H$, $\overline{CE}_2 = H$ or $CE_2 = L$.
3. Device Outputs are ensured to be in High-Z after the first rising edge of clock upon power-up.

Write Operation with Chip Enable Used⁽¹⁾

| Cycle | Address | R \overline{W} | ADV/ \overline{LD} | $\overline{CE}^{(2)}$ | \overline{CEN} | \overline{BW}_x | \overline{OE} | I/O ⁽³⁾ | Comments |
|-------|----------------|------------------|----------------------|-----------------------|------------------|-------------------|-----------------|--------------------|--------------------------------------------------------|
| n | X | X | L | H | L | X | X | ? | Deselected. |
| n+1 | X | X | L | H | L | X | X | ? | Deselected. |
| n+2 | A ₀ | L | L | L | L | L | X | Z | Address and Control meet setup |
| n+3 | X | X | L | H | L | X | X | Z | Deselected or STOP. |
| n+4 | A ₁ | L | L | L | L | L | X | D ₀ | Address D ₀ Write in. Load A ₁ . |
| n+5 | X | X | L | H | L | X | X | Z | Deselected or STOP. |
| n+6 | X | X | L | H | L | X | X | D ₁ | Address D ₁ Write in. Deselected. |
| n+7 | A ₂ | L | L | L | L | L | X | Z | Address and control meet setup. |
| n+8 | X | X | L | H | L | X | X | Z | Deselected or STOP. |
| n+9 | X | X | L | H | L | X | X | D ₂ | Address D ₂ Write in. Deselected. |

5304 tbl 20

NOTES:

1. H = High; L = Low; X = Don't Care; ? = Don't Know; Z = High Impedance.
2. $\overline{CE} = L$ is defined as $\overline{CE}_1 = L$, $\overline{CE}_2 = L$ and $CE_2 = H$. $\overline{CE} = H$ is defined as $\overline{CE}_1 = H$, $\overline{CE}_2 = H$ or $CE_2 = L$.

DC Electrical Characteristics Over the Operating Temperature and Supply Voltage Range ($V_{DD} = 3.3V \pm 5\%$)

| Symbol | Parameter | Test Conditions | Min. | Max. | Unit |
|------------|-------------------------------------------------------|--------------------------------------------------------|------|------|---------|
| $ I_{LI} $ | Input Leakage Current | $V_{DD} = \text{Max.}, V_{IN} = 0V \text{ to } V_{DD}$ | — | 5 | μA |
| $ I_{LI} $ | \overline{LBO} Input Leakage Current ⁽¹⁾ | $V_{DD} = \text{Max.}, V_{IN} = 0V \text{ to } V_{DD}$ | — | 30 | μA |
| $ I_{LO} $ | Output Leakage Current | $V_{OUT} = 0V \text{ to } V_{DDQ}$, Device Deselected | — | 5 | μA |
| V_{OL} | Output Low Voltage | $I_{OL} = +8mA, V_{DD} = \text{Min.}$ | — | 0.4 | V |
| V_{OH} | Output High Voltage | $I_{OH} = -8mA, V_{DD} = \text{Min.}$ | 2.4 | — | V |

NOTE:

1. The \overline{LBO} pin will be internally pulled to V_{DD} if it is not actively driven in the application and the ZZ pin will be internally pulled to V_{SS} if not actively driven.

5304 tbl 21

DC Electrical Characteristics Over the Operating Temperature and Supply Voltage Range⁽¹⁾ ($V_{DD} = 3.3V \pm 5\%$)

| Symbol | Parameter | Test Conditions | 150MHz | | 133MHz | | 100MHz | | Unit |
|-----------|------------------------------------|-------------------------------------------------------------------------------------------------------------------------------------------------------------------|--------|-----|--------|-----|--------|-----|------|
| | | | Com'l | Ind | Com'l | Ind | Com'l | Ind | |
| I_{DD} | Operating Power Supply Current | Device Selected, Outputs Open, $ADV/\overline{LD} = X, V_{DD} = \text{Max.}, V_{IN} \geq V_{IH} \text{ or } \leq V_{IL}, f = f_{MAX}^{(2)}$ | 325 | 345 | 300 | 320 | 250 | 270 | mA |
| I_{SB1} | CMOS Standby Power Supply Current | Device Deselected, Outputs Open, $V_{DD} = \text{Max.}, V_{IN} \geq V_{HD} \text{ or } \leq V_{LD}, f = 0^{(2,3)}$ | 40 | 60 | 40 | 60 | 40 | 60 | mA |
| I_{SB2} | Clock Running Power Supply Current | Device Deselected, Outputs Open, $V_{DD} = \text{Max.}, V_{IN} \geq V_{HD} \text{ or } < V_{LD}, f = f_{MAX}^{(2,3)}$ | 120 | 140 | 110 | 130 | 100 | 120 | mA |
| I_{SB3} | Idle Power Supply Current | Device Selected, Outputs Open, $\overline{CEN} \geq V_{IH}, V_{DD} = \text{Max.}, V_{IN} \geq V_{HD} \text{ or } \leq V_{LD}, f = f_{MAX}^{(2,3)}$ | 40 | 60 | 40 | 60 | 40 | 60 | mA |
| I_{ZZ} | Full Sleep Mode Supply Current | Device Selected, Outputs Open $\overline{CEN} \leq V_{IL}, V_{DD} = \text{Max.}, ZZ \geq V_{HD}, V_{IN} \geq V_{HD} \text{ or } \leq V_{LD}, f = f_{MAX}^{(2,3)}$ | 40 | 60 | 40 | 60 | 40 | 60 | mA |

NOTES:

- All values are maximum guaranteed values.
- At $f = f_{MAX}$, inputs are cycling at the maximum frequency of read cycles of $1/t_{CYC}$; $f=0$ means no input lines are changing.
- For I/Os $V_{HD} = V_{DDQ} - 0.2V, V_{LD} = 0.2V$. For other inputs $V_{HD} = V_{DD} - 0.2V, V_{LD} = 0.2V$.

5304 tbl 22

AC Test Load

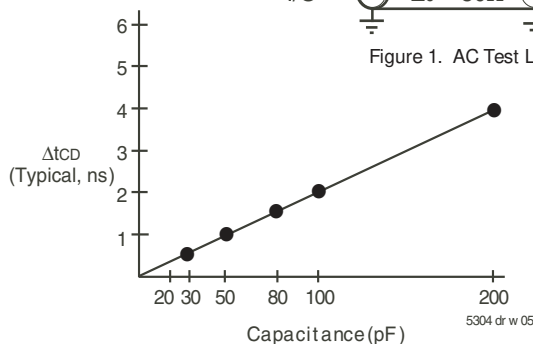
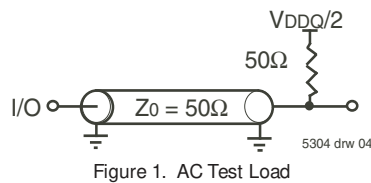

Figure 2. Lumped Capacitive Load, Typical Derating

AC Test Conditions ($V_{DDQ} = 3.3V$)

| | |
|--------------------------------|--------------|
| Input Pulse Levels | 0 to 3V |
| Input Rise/Fall Times | 2ns |
| Input Timing Reference Levels | 1.5V |
| Output Timing Reference Levels | 1.5V |
| AC Test Load | See Figure 1 |

5304 tbl 23

AC Electrical Characteristics

(VDD = 3.3V +/-5%, Commercial and Industrial Temperature Ranges)

| Symbol | Parameter | 150MHz ⁽⁶⁾ | | 133MHz | | 100MHz | | Unit |
|-------------------------------------|----------------------------------------------------------|-----------------------|------|--------|------|--------|------|------|
| | | Min. | Max. | Min. | Max. | Min. | Max. | |
| t _{CYC} | Clock Cycle Time | 6.7 | — | 7.5 | — | 10 | — | ns |
| t _F ⁽¹⁾ | Clock Frequency | — | 150 | — | 133 | — | 100 | MHz |
| t _{CH} ⁽²⁾ | Clock High Pulse Width | 2.0 | — | 2.2 | — | 3.2 | — | ns |
| t _{CL} ⁽²⁾ | Clock Low Pulse Width | 2.0 | — | 2.2 | — | 3.2 | — | ns |
| Output Parameters | | | | | | | | |
| t _{CD} | Clock High to Valid Data | — | 3.8 | — | 4.2 | — | 5 | ns |
| t _{ODC} | Clock High to Data Change | 1.5 | — | 1.5 | — | 1.5 | — | ns |
| t _{CLZ} ^(3,4,5) | Clock High to Output Active | 1.5 | — | 1.5 | — | 1.5 | — | ns |
| t _{CHZ} ^(3,4,5) | Clock High to Data High-Z | 1.5 | 3 | 1.5 | 3 | 1.5 | 3.3 | ns |
| t _{OE} | Output Enable Access Time | — | 3.8 | — | 4.2 | — | 5 | ns |
| t _{OLZ} ^(3,4) | Output Enable Low to Data Active | 0 | — | 0 | — | 0 | — | ns |
| t _{OHZ} ^(3,4) | Output Enable High to Data High-Z | — | 3.8 | — | 4.2 | — | 5 | ns |
| Set Up Times | | | | | | | | |
| t _{SE} | Clock Enable Setup Time | 1.5 | — | 1.7 | — | 2.0 | — | ns |
| t _{SA} | Address Setup Time | 1.5 | — | 1.7 | — | 2.0 | — | ns |
| t _{SD} | Data In Setup Time | 1.5 | — | 1.7 | — | 2.0 | — | ns |
| t _{SW} | Read/Write (R/ \bar{W}) Setup Time | 1.5 | — | 1.7 | — | 2.0 | — | ns |
| t _{SADV} | Advance/Load (ADV/ \bar{LD}) Setup Time | 1.5 | — | 1.7 | — | 2.0 | — | ns |
| t _{SC} | Chip Enable/Select Setup Time | 1.5 | — | 1.7 | — | 2.0 | — | ns |
| t _{SB} | Byte Write Enable ($\bar{B}\bar{W}\bar{x}$) Setup Time | 1.5 | — | 1.7 | — | 2.0 | — | ns |
| Hold Times | | | | | | | | |
| t _{HE} | Clock Enable Hold Time | 0.5 | — | 0.5 | — | 0.5 | — | ns |
| t _{HA} | Address Hold Time | 0.5 | — | 0.5 | — | 0.5 | — | ns |
| t _{HD} | Data In Hold Time | 0.5 | — | 0.5 | — | 0.5 | — | ns |
| t _{HW} | Read/Write (R/ \bar{W}) Hold Time | 0.5 | — | 0.5 | — | 0.5 | — | ns |
| t _{HADV} | Advance/Load (ADV/ \bar{LD}) Hold Time | 0.5 | — | 0.5 | — | 0.5 | — | ns |
| t _{HC} | Chip Enable/Select Hold Time | 0.5 | — | 0.5 | — | 0.5 | — | ns |
| t _{HB} | Byte Write Enable ($\bar{B}\bar{W}\bar{x}$) Hold Time | 0.5 | — | 0.5 | — | 0.5 | — | ns |

5304 tbl 24

NOTES:

- t_F = 1/t_{CYC}.
- Measured as HIGH above 0.6V_{DDQ} and LOW below 0.4V_{DDQ}.
- Transition is measured ±200mV from steady-state.
- These parameters are guaranteed with the AC load (Figure 1) by device characterization. They are not production tested.
- To avoid bus contention, the output buffers are designed such that t_{CHZ} (device turn-off) is about 1ns faster than t_{CLZ} (device turn-on) at a given temperature and voltage. The specs as shown do not imply bus contention because t_{CLZ} is a Min. parameter that is worse case at totally different test conditions (0 deg. C, 3.465V) than t_{CHZ}, which is a Max. parameter (worse case at 70 deg. C, 3.135V).
- Commercial temperature range only.

Timing Waveform of Read Cycle^(1,2,3,4)

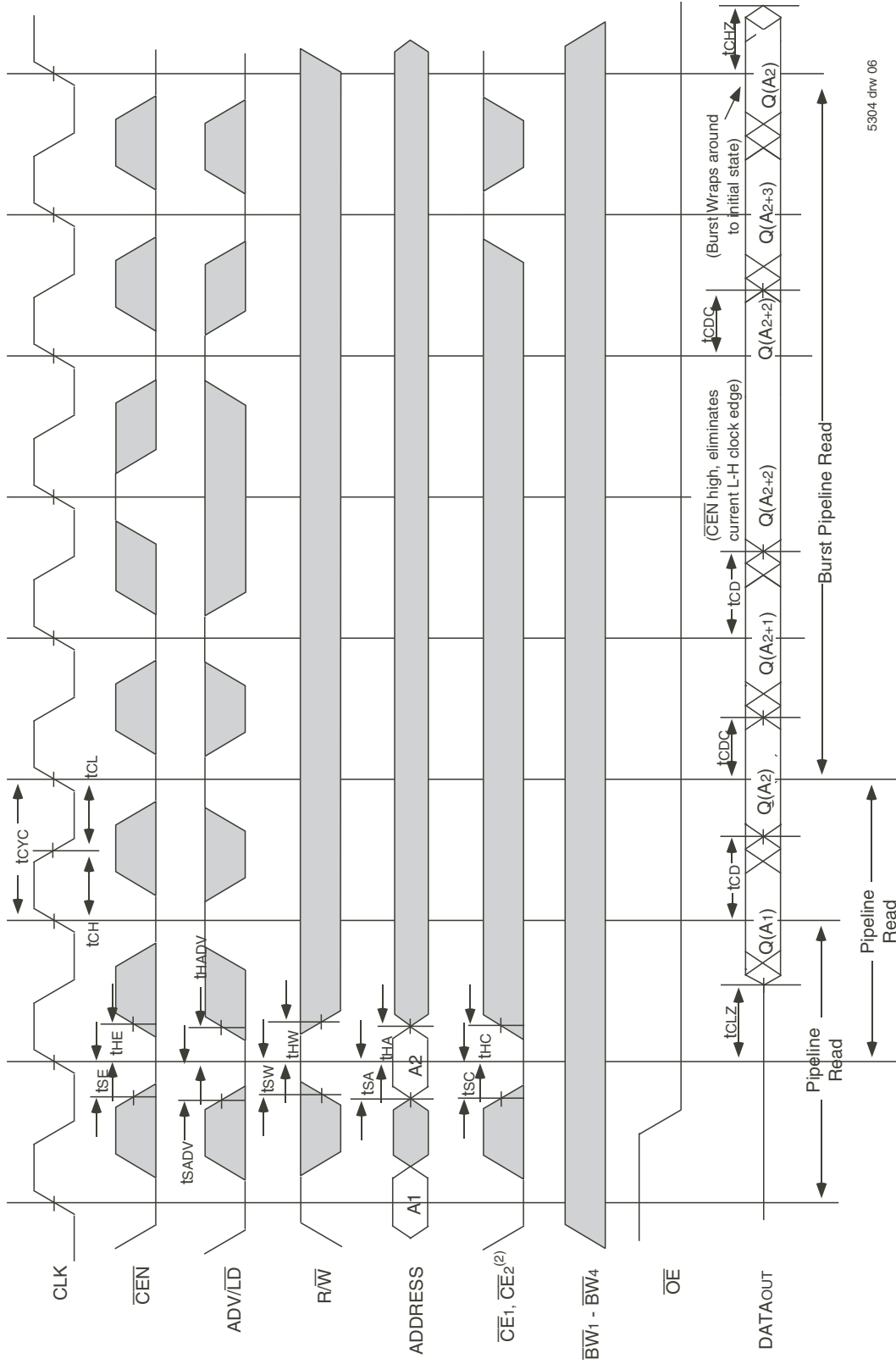

5304 drw 06

NOTES:

1. Q(A1) represents the first output from the external address A1. Q(A2) represents the first output from the external address A2; Q(A2+1) represents the next output data in the burst sequence of the base address A2, etc. where address bits A0 and A1 are advancing for the four word burst in the sequence defined by the state of the \overline{LBO} input.
2. CE2 timing transitions are identical but inverted to the $\overline{CE1}$ and $\overline{CE2}$ signals. For example, when $\overline{CE1}$ and $\overline{CE2}$ are LOW on this waveform, CE2 is HIGH.
3. Burst ends when new address and control are loaded into the SRAM by sampling ADV/LD LOW.
4. R/W is don't care when the SRAM is bursting (ADV/LD sampled HIGH). The nature of the burst access (Read or Write) is fixed by the state of the R/W signal when new address and control are loaded into the SRAM.

Timing Waveform of Write Cycles^(1,2,3,4,5)

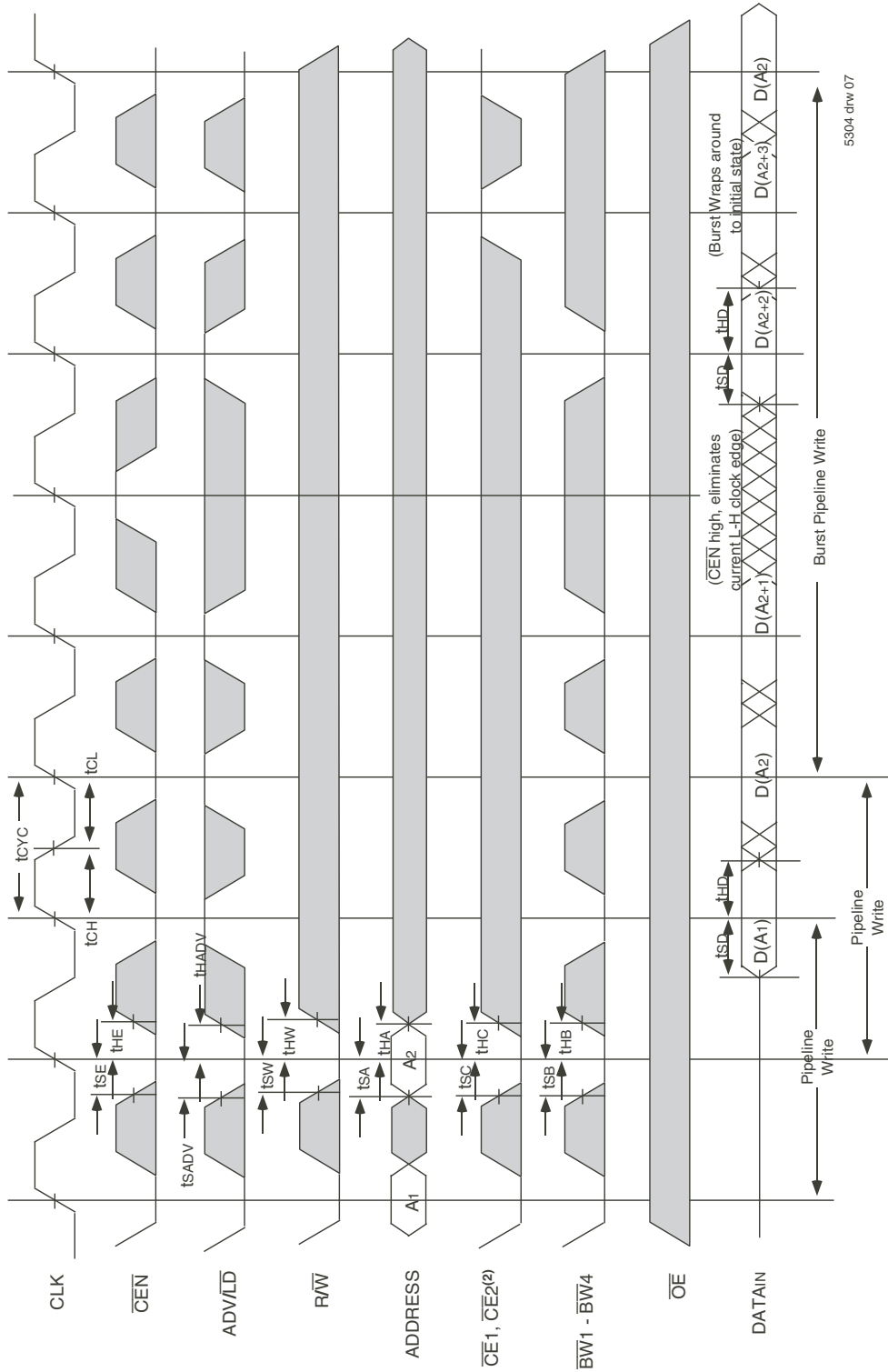

5304 drw 07

NOTES:

1. D (A1) represents the first input to the external address A1. D (A2) represents the first input to the external address A2; D (A2+1) represents the next input data in the burst sequence of the base address A2, etc. where address bits A0 and A1 are advancing for the four word burst in the sequence defined by the state of the LBO input.
2. CE2 timing transitions are identical but inverted to the CE1 and CE2 signals. For example, when CE1 and CE2 are LOW on this waveform, CE2 is HIGH.
3. Burst ends when new address and control are loaded into the SRAM by sampling ADVLD LOW.
4. RW is don't care when the SRAM is bursting (ADVLD sampled HIGH). The nature of the burst access (Read or Write) is fixed by the state of the RW signal when new address and control are loaded into the SRAM.
5. Individual Byte Write signals (BWx) must be valid on all write and burst-write cycles. A write cycle is initiated when RW signal is sampled LOW. The byte write information comes in two cycles before the actual data is presented to the SRAM.

Timing Waveform of Combined Read and Write Cycles^(1,2,3)

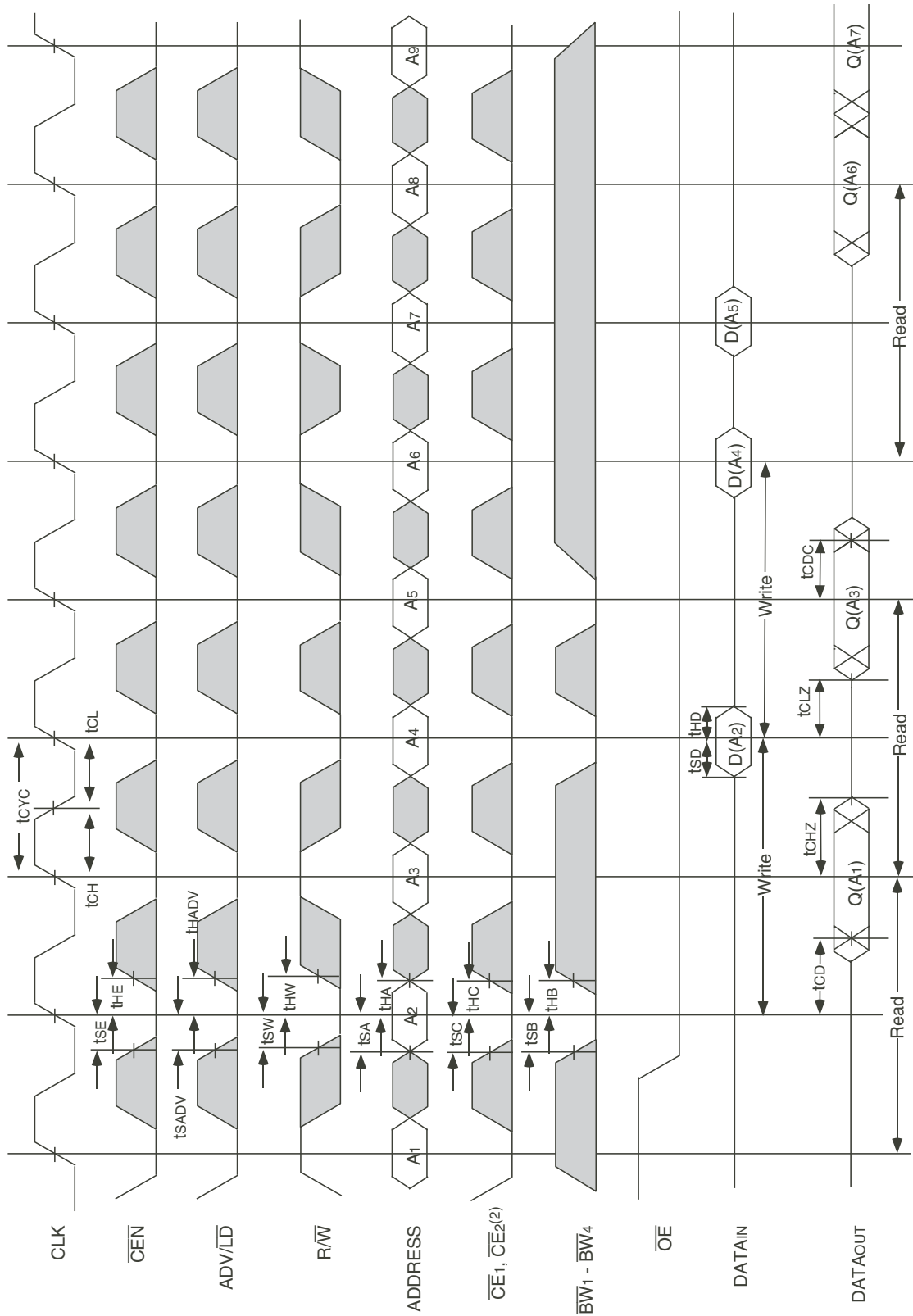

5304 drw 08

NOTES:

1. Q(A₁) represents the first output from the external address A₁. D(A₂) represents the input data to the SRAM corresponding to address A₂.
2. CE₂ timing transitions are identical but inverted to the CE₁ and OE₂ signals. For example, when CE₁ and OE₂ are LOW on this waveform, CE₂ is HIGH.
3. Individual Byte Write signals (BW_x) must be valid on all write and burst-write cycles. A write cycle is initiated when R/W signal is sampled LOW. The byte write information comes in two cycles before the actual data is presented to the SRAM.

Timing Waveform of $\overline{\text{CEN}}$ Operation^(1,2,3,4)

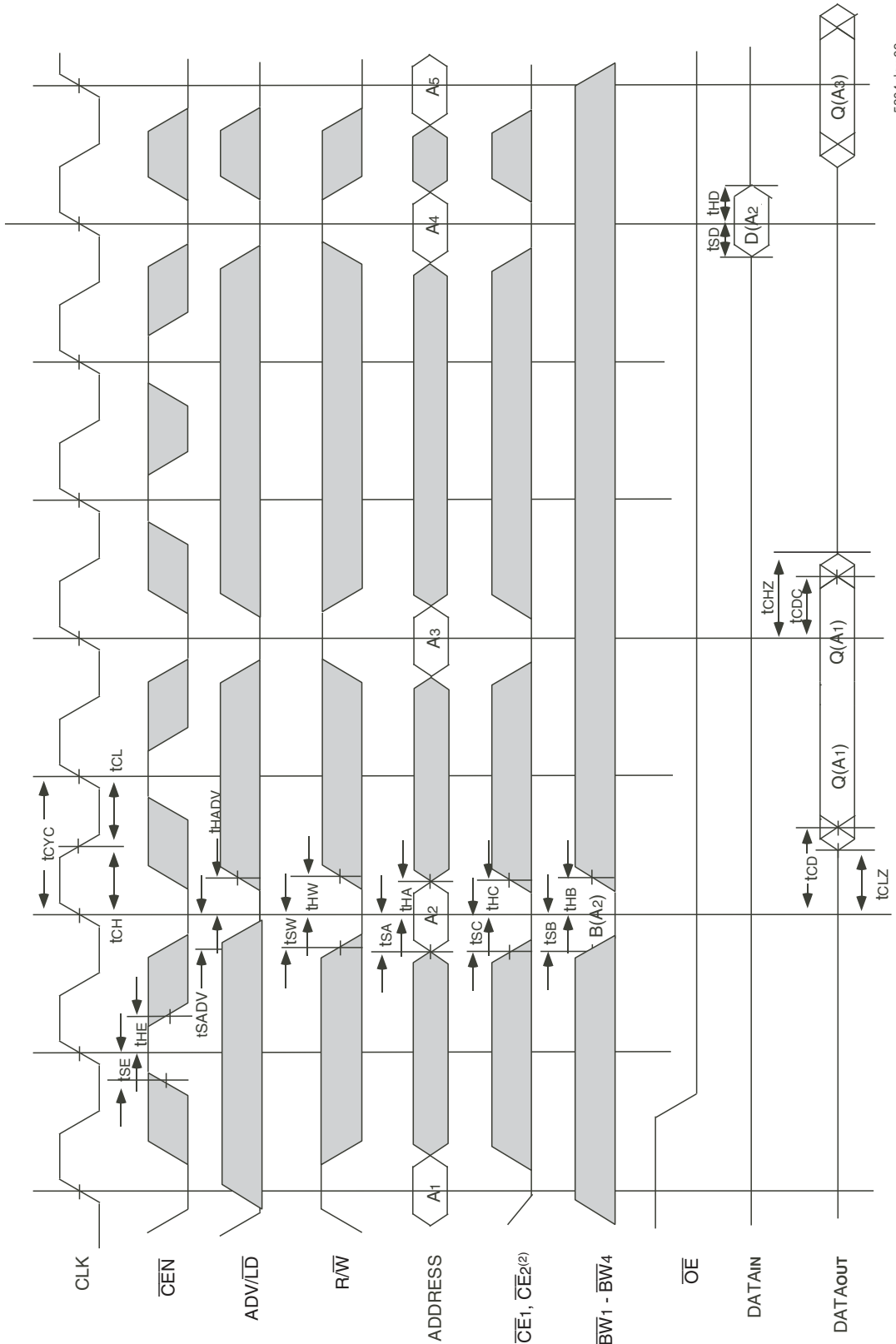

5304 dhw 09

NOTES:

1. Q(A1) represents the first output from the external address A1. D(A2) represents the input data to the SRAM corresponding to address A2.
2. $\overline{\text{CE}}_1$ and $\overline{\text{CE}}_2$ signals are identical but inverted to the $\overline{\text{CEN}}$ and $\overline{\text{CE}}_2$ signals. For example, when $\overline{\text{CE}}_1$ and $\overline{\text{CE}}_2$ are LOW on this waveform, $\overline{\text{CE}}_2$ is HIGH.
3. $\overline{\text{CEN}}$ when sampled high on the rising edge of clock will block that L-H transition of the clock from propagating into the SRAM. The part will behave as if the L-H clock transition did not occur. All internal registers in the SRAM will retain their previous state.
4. Individual Byte Write signals (BWx) must be valid on all write and burst-write cycles. A write cycle is initiated when $\overline{\text{R}}/\overline{\text{W}}$ signal is sampled LOW. The byte write information comes in two cycles before the actual data is presented to the SRAM.

Timing Waveform of \overline{CS} Operation^(1,2,3,4)

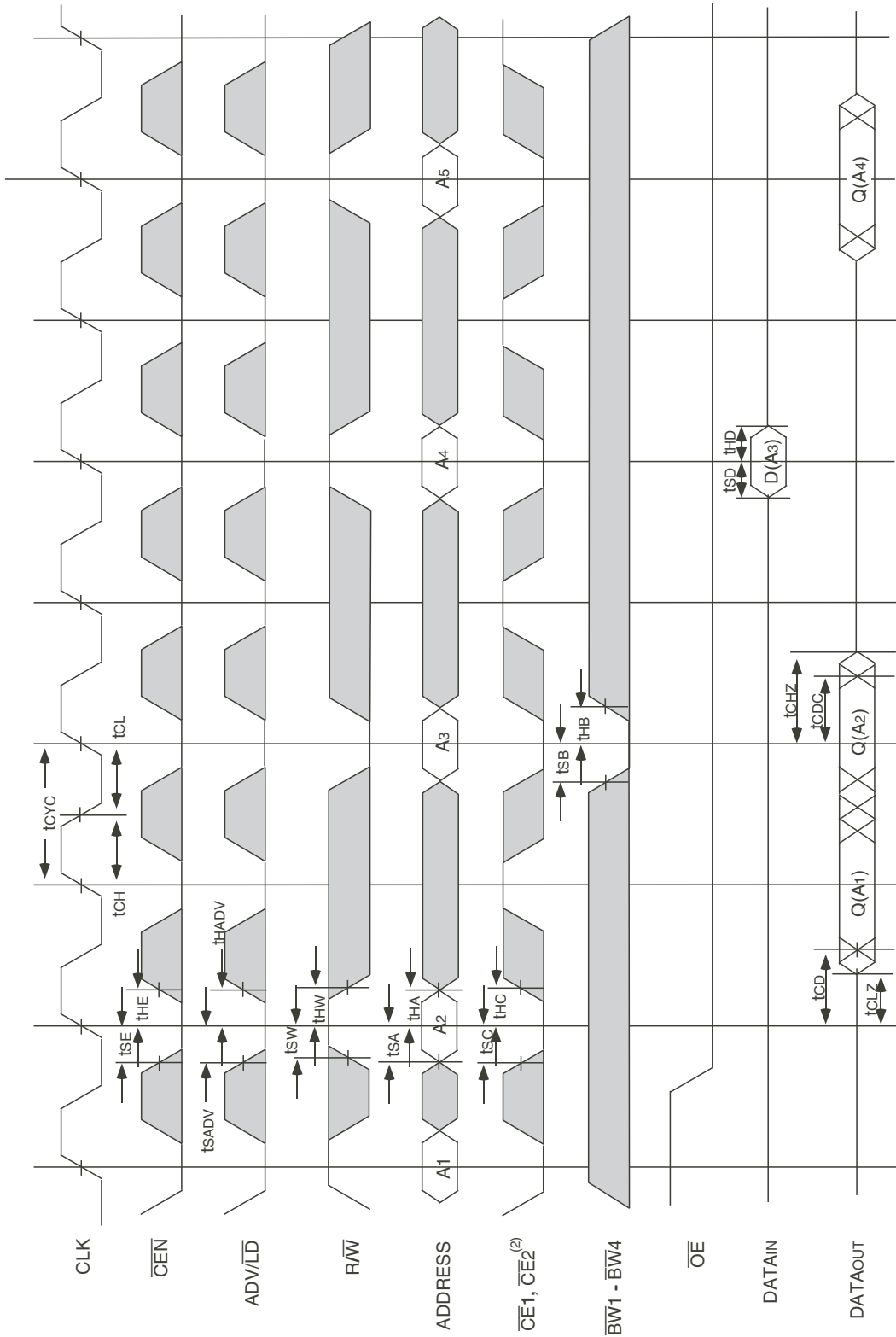

5304 drw 10

NOTES:

1. Q(A₁) represents the first output from the external address A₁. D(A₃) represents the input data to the SRAM corresponding to address A₃.
2. $\overline{CE2}$ timing transitions are identical but inverted to the $\overline{CE1}$ and $\overline{CE2}$ signals. For example, when $\overline{CE1}$ and $\overline{CE2}$ are LOW on this waveform, $\overline{CE2}$ is HIGH.
3. \overline{CEN} when sampled high on the rising edge of clock will block that L-H transition of the clock from propagating into the SRAM. The part will behave as if the L-H clock transition did not occur. All internal registers in the SRAM will retain their previous state.
4. Individual Byte Write signals (BWx) must be valid on all write and burst-write cycles. A write cycle is initiated when $\overline{R/W}$ signal is sampled LOW. The byte write information comes in two cycles before the actual data is presented to the SRAM.

Timing Waveform of \overline{OE} Operation⁽¹⁾

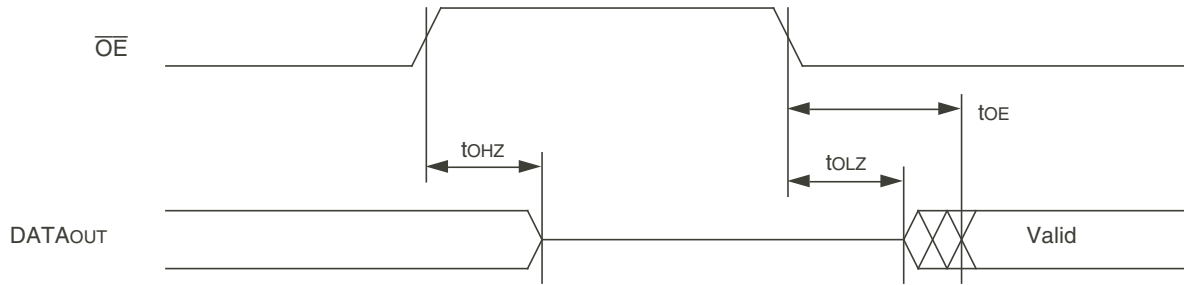

5304 drw 11

NOTE:

1. A read operation is assumed to be in progress.

Ordering Information

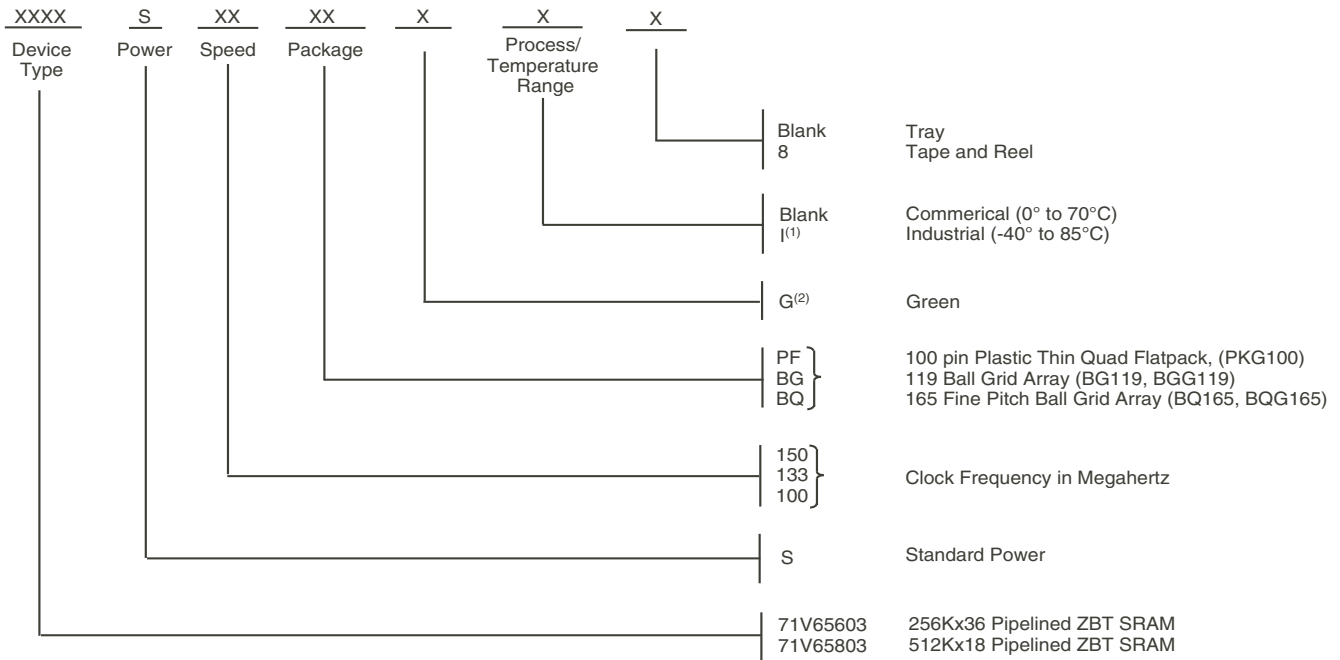

5304 drw 12

NOTES:

1. Contact your local sales office for Industrial temp range for other speeds, packages and powers.
2. Green parts available. For specific speeds, packages and powers contact your local sales office.

Orderable Part Information

| Speed (MHz) | Orderable Part ID | Pkg. Code | Pkg. Type | Temp. Grade | |
|-------------------|-------------------|-----------------|-----------|-------------|---|
| 100 | 71V65603S100BG | BG119 | PBGA | C | |
| | 71V65603S100BG8 | BG119 | PBGA | C | |
| | 71V65603S100BGI | BG119 | PBGA | I | |
| | 71V65603S100BGI8 | BG119 | PBGA | I | |
| | 71V65603S100BQ | BQ165 | CABGA | C | |
| | 71V65603S100BQG | BQG165 | CABGA | C | |
| | 71V65603S100BQG8 | BQG165 | CABGA | C | |
| | 71V65603S100BQGI | BQG165 | CABGA | I | |
| | 71V65603S100BQGI8 | BQG165 | CABGA | I | |
| | 71V65603S100BQI | BQ165 | CABGA | I | |
| | 71V65603S100PFG | PKG100 | TQFP | C | |
| | 71V65603S100PFG8 | PKG100 | TQFP | C | |
| | 71V65603S100PFGI | PKG100 | TQFP | I | |
| | 71V65603S100PFGI8 | PKG100 | TQFP | I | |
| | 133 | 71V65603S133BG | BG119 | PBGA | C |
| | | 71V65603S133BG8 | BG119 | PBGA | C |
| 71V65603S133BGG | | BGG119 | PBGA | C | |
| 71V65603S133BGG8 | | BGG119 | PBGA | C | |
| 71V65603S133BGGI | | BGG119 | PBGA | I | |
| 71V65603S133BGGI8 | | BGG119 | PBGA | I | |
| 71V65603S133BGI | | BG119 | PBGA | I | |
| 71V65603S133BGI8 | | BG119 | PBGA | I | |
| 71V65603S133BQ | | BQ165 | CABGA | C | |
| 71V65603S133BQG | | BQG165 | CABGA | C | |
| 71V65603S133BQG8 | | BQG165 | CABGA | C | |
| 71V65603S133BQGI | | BQG165 | CABGA | I | |
| 71V65603S133BQGI8 | | BQG165 | CABGA | I | |
| 71V65603S133BQI | | BQ165 | CABGA | I | |
| 71V65603S133PFG | | PKG100 | TQFP | C | |
| 71V65603S133PFG8 | | PKG100 | TQFP | C | |
| 71V65603S133PFGI | | PKG100 | TQFP | I | |
| 71V65603S133PFGI8 | | PKG100 | TQFP | I | |

| Speed (MHz) | Orderable Part ID | Pkg. Code | Pkg. Type | Temp. Grade |
|-------------|-------------------|-----------|-----------|-------------|
| 150 | 71V65603S150BG | BG119 | PBGA | C |
| | 71V65603S150BG8 | BG119 | PBGA | C |
| | 71V65603S150BGG | BGG119 | PBGA | C |
| | 71V65603S150BGG8 | BGG119 | PBGA | C |
| | 71V65603S150BGGI | BGG119 | PBGA | I |
| | 71V65603S150BGGI8 | BGG119 | PBGA | I |
| | 71V65603S150BQ | BQ165 | CABGA | C |
| | 71V65603S150BQ8 | BQ165 | CABGA | C |
| | 71V65603S150BQG | BQG165 | CABGA | C |
| | 71V65603S150BQG8 | BQG165 | CABGA | C |
| | 71V65603S150BQGI | BQG165 | CABGA | I |
| | 71V65603S150BQGI8 | BQG165 | CABGA | I |
| | 71V65603S150BQI | BQ165 | CABGA | I |
| | 71V65603S150BQI8 | BQ165 | CABGA | I |
| | 71V65603S150PFG | PKG100 | TQFP | C |
| | 71V65603S150PFG8 | PKG100 | TQFP | C |
| | 71V65603S150PFGI | PKG100 | TQFP | I |
| | 71V65603S150PFGI8 | PKG100 | TQFP | I |

Orderable Part Information(con't)

| Speed (MHz) | Orderable Part ID | Pkg. Code | Pkg. Type | Temp. Grade | |
|-------------------|-------------------|-----------------|-----------|-------------|---|
| 100 | 71V65803S100BG | BG119 | PBGA | C | |
| | 71V65803S100BG8 | BG119 | PBGA | C | |
| | 71V65803S100BGG | BGG119 | PBGA | C | |
| | 71V65803S100BGG8 | BGG119 | PBGA | C | |
| | 71V65803S100BGGI | BGG119 | PBGA | I | |
| | 71V65803S100BGGI8 | BGG119 | PBGA | I | |
| | 71V65803S100BGI | BG119 | PBGA | I | |
| | 71V65803S100BGI8 | BG119 | PBGA | I | |
| | 71V65803S100BQ | BQ165 | CABGA | C | |
| | 71V65803S100BQG | BQG165 | CABGA | C | |
| | 71V65803S100BQG8 | BQG165 | CABGA | C | |
| | 71V65803S100BQI | BQ165 | CABGA | I | |
| | 71V65803S100PFG | PKG100 | TQFP | C | |
| | 71V65803S100PFG8 | PKG100 | TQFP | C | |
| | 71V65803S100PFGI | PKG100 | TQFP | I | |
| | 71V65803S100PFGI8 | PKG100 | TQFP | I | |
| | 133 | 71V65803S133BG | BG119 | PBGA | C |
| | | 71V65803S133BG8 | BG119 | PBGA | C |
| 71V65803S133BGG | | BGG119 | PBGA | C | |
| 71V65803S133BGG8 | | BGG119 | PBGA | C | |
| 71V65803S133BGGI | | BGG119 | PBGA | I | |
| 71V65803S133BGGI8 | | BGG119 | PBGA | I | |
| 71V65803S133BGI | | BG119 | PBGA | I | |
| 71V65803S133BGI8 | | BG119 | PBGA | I | |
| 71V65803S133BQ | | BQ165 | CABGA | C | |
| 71V65803S133BQG | | BQG165 | CABGA | C | |
| 71V65803S133BQG8 | | BQG165 | CABGA | C | |
| 71V65803S133BQI | | BQ165 | CABGA | I | |
| 71V65803S133BQI8 | | BQ165 | CABGA | I | |
| 71V65803S133PFG | | PKG100 | TQFP | C | |
| 71V65803S133PFG8 | | PKG100 | TQFP | C | |
| 71V65803S133PFGI | | PKG100 | TQFP | I | |
| 71V65803S133PFGI8 | | PKG100 | TQFP | I | |

| Speed (MHz) | Orderable Part ID | Pkg. Code | Pkg. Type | Temp. Grade |
|-------------|-------------------|-----------|-----------|-------------|
| 150 | 71V65803S150BG | BG119 | PBGA | C |
| | 71V65803S150BG8 | BG119 | PBGA | C |
| | 71V65803S150BGI | BG119 | PBGA | I |
| | 71V65803S150BGI8 | BG119 | PBGA | I |
| | 71V65803S150BQ | BQ165 | CABGA | C |
| | 71V65803S150BQG | BQG165 | CABGA | C |
| | 71V65803S150BQG8 | BQG165 | CABGA | C |
| | 71V65803S150BQI | BQ165 | CABGA | I |
| | 71V65803S150BQI8 | BQ165 | CABGA | I |
| | 71V65803S150PFG | PKG100 | TQFP | C |
| | 71V65803S150PFG8 | PKG100 | TQFP | C |
| | 71V65803S150PFGI | PKG100 | TQFP | I |
| | 71V65803S150PFGI8 | PKG100 | TQFP | I |

Datasheet Document History

| | | |
|----------|-----------------|------------------------------------------------------------------------------------------------------------------------------------------------|
| 12/31/99 | | Created new datasheet from obsolete devices IDT71V656 and IDT71V658 |
| 03/04/00 | Pg. 1,14,15 | Removed 166MHz speed grade offering; Added 150MHz speed grade offering |
| 04/20/00 | Pg. 5,6 | Added JTAG test pins to TQFP pin configuration; removed footnote |
| | Pg. 5,6 | Add clarification note to Recommended Operating temperature and Absolute Max Ratings tables |
| | Pg. 7 | Add note to BGA pin Configuration; correct typo within pinout |
| | Pg. 21 | Insert TQFP Package Diagram Outline |
| 05/23/00 | | Add new package offering, 13 x 15mm 165 fBGA |
| | Pg. 23 | Correction in BG 119 Package Diagram Outline |
| 07/28/00 | | Add industrial temperature |
| | Pg. 2 | Correction V _{DDQ} 3.3V I/O supply |
| | Pg. 5-8 | Remove JTAG offerings, refer to IDT71V656xx and IDT71V658xx device errata sheet |
| | Pg. 7 | Correct pin B2 |
| | Pg. 8 | Change pin B1 to NC |
| | Pg. 23 | Update BG119 Package Diagram Outline |
| 11/04/00 | Pg. 8 | Add note to pin N5 on BQ165 pinout, reserved for JTAG $\overline{\text{TRST}}$ |
| | Pg. 15 | Add I _{ZZ} parameter to DC Electrical Characteristics |
| 10/16/01 | Pg. 16 | Changed sub-header to include Commercial and Industrial Temperature Ranges. Corrected the TCH from 22ns to 2.2ns and TSADV from 20ns to 2.0ns. |
| 12/04/02 | Pg. 1-25 | Changed datasheet from Preliminary to final release. |
| | Pg. 15 | Added I temp to 150MHz. |
| | Pg. 16 | Corrected typo from 22 to 2.2. |
| 12/19/02 | Pg. 1,2,5,6,7,8 | Removed JTAG functionality for current die revision. |
| | Pg. 7 | Corrected pin configuration on the x36, 119BGA. Switched pins I/O0 and I/OP1. |
| 09/30/04 | Pg. 5,6 | Updated temperature T _A note. |
| | Pg. 7 | Updated pin configuration for the 119BGA-reordered I/O signals on P7,N6,L6, K7,H6, G7, F6, E7, D6 (512K x18). |
| | Pg. 25 | Added "restricted hazardous substance device" to ordering information. |
| 02/21/07 | Pg. 25 | Added Z generation die step to data sheet ordering information. |
| 10/16/08 | Pg. 25 | Updated the ordering information by removing the "IDT" notation. |
| 11/12/21 | Pg. 1 - 27 | Source file updated to reflect previous Corporate Marketing rebranding |
| | Pg. 1 & 23 | Removed Z stepping information |
| | Pg. 1 & 23 | Updated Industrial temp range, green availability and package codes |
| | Pg. 23 | Added Tape & Reel and green to ordering information |
| | Pg. 5 - 8 | Updated package codes |
| | Pg. 22 - 24 | Deleted all Package Diagram Outlines |
| | Pg. 24 - 25 | Added Orderable Part Information tables |

IMPORTANT NOTICE AND DISCLAIMER

RENESAS ELECTRONICS CORPORATION AND ITS SUBSIDIARIES (“RENESAS”) PROVIDES TECHNICAL SPECIFICATIONS AND RELIABILITY DATA (INCLUDING DATASHEETS), DESIGN RESOURCES (INCLUDING REFERENCE DESIGNS), APPLICATION OR OTHER DESIGN ADVICE, WEB TOOLS, SAFETY INFORMATION, AND OTHER RESOURCES “AS IS” AND WITH ALL FAULTS, AND DISCLAIMS ALL WARRANTIES, EXPRESS OR IMPLIED, INCLUDING, WITHOUT LIMITATION, ANY IMPLIED WARRANTIES OF MERCHANTABILITY, FITNESS FOR A PARTICULAR PURPOSE, OR NON-INFRINGEMENT OF THIRD PARTY INTELLECTUAL PROPERTY RIGHTS.

These resources are intended for developers skilled in the art designing with Renesas products. You are solely responsible for (1) selecting the appropriate products for your application, (2) designing, validating, and testing your application, and (3) ensuring your application meets applicable standards, and any other safety, security, or other requirements. These resources are subject to change without notice. Renesas grants you permission to use these resources only for development of an application that uses Renesas products. Other reproduction or use of these resources is strictly prohibited. No license is granted to any other Renesas intellectual property or to any third party intellectual property. Renesas disclaims responsibility for, and you will fully indemnify Renesas and its representatives against, any claims, damages, costs, losses, or liabilities arising out of your use of these resources. Renesas' products are provided only subject to Renesas' Terms and Conditions of Sale or other applicable terms agreed to in writing. No use of any Renesas resources expands or otherwise alters any applicable warranties or warranty disclaimers for these products.

(Disclaimer Rev.1.0 Mar 2020)

Corporate Headquarters

TOYOSU FORESIA, 3-2-24 Toyosu,
Koto-ku, Tokyo 135-0061, Japan
www.renesas.com

Contact Information

For further information on a product, technology, the most up-to-date version of a document, or your nearest sales office, please visit:
www.renesas.com/contact/

Trademarks

Renesas and the Renesas logo are trademarks of Renesas Electronics Corporation. All trademarks and registered trademarks are the property of their respective owners.