

# Serial GLCD 240x64 Adapter™

## Manual

*All Mikroelektronika's development systems feature a large number of peripheral modules expanding microcontroller's range of application and making the process of program testing easier. In addition to these modules, it is also possible to use numerous additional modules linked to the development system through the I/O port connectors. Some of these additional modules can operate as stand-alone devices without being connected to the microcontroller.*

# Additional board

 **MikroElektronika**

SOFTWARE AND HARDWARE SOLUTIONS FOR EMBEDDED WORLD ...making it simple

## Serial GLCD 240x64 Adapter

The Serial GLCD 240x64 Adapter additional board is used to connect a GLCD 240x64 display to a development system via the Serial Peripheral Interface (SPI).

### Key features:

- Serial SPI communication;
- Display contrast adjustable;
- 5V power supply voltage.



Figure 1: Serial GLCD 240x64 Adapter

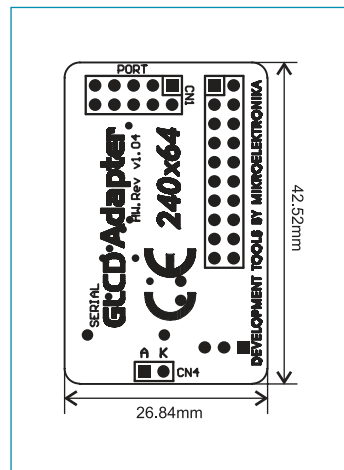

Figure 2: Dimensions of the board

### How to connect the board?

The Serial GLCD 240x64 Adapter board can be easily connected to a development system via an IDC10 connector CN1 on the flat cable. The board is connected to the development system I/O port that is also connected to the SPI module built into the microcontroller. A 2x10 connector CN3 is used to establish connection with a GLCD 240x64 display. Its backlight is connected via pads CN4. A pad marked K should be connected to a cathode, whereas a pad marked A should be connected to an anode of the LED diode. Potentiometer P1 is used to adjust display contrast. SMD jumpers are used to select a development system to connect the board to. By default, these jumpers are placed in the PIC position. If you want to use another development system, it is necessary to unsolder them first, then solder them in the position for AVR and 8051 development systems.

Here you can find examples for the Serial GLCD 240x64 Adapter board:

<http://www.mikroe.com/eng/products/view/273/serial-glcd-240x64-adapter-board/>

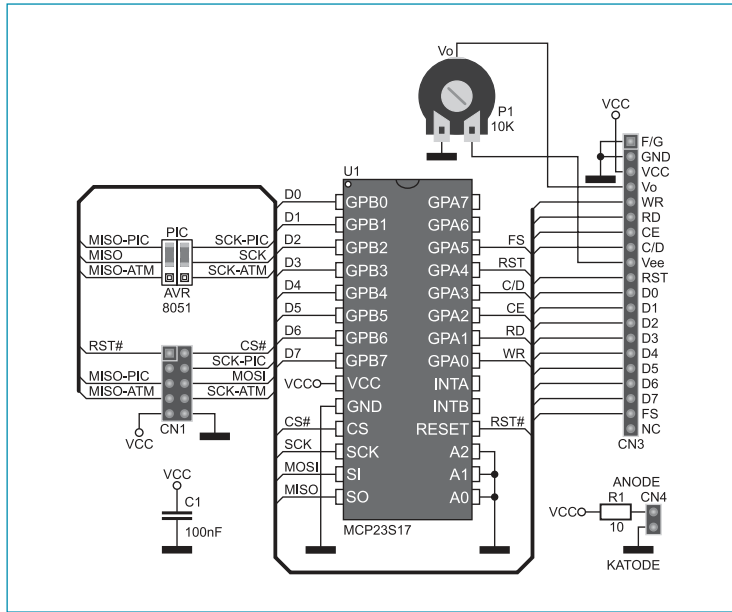

Figure 3: Serial GLCD 240x64 Adapter board connection schematic



**MikroElektronika**  
SOFTWARE AND HARDWARE SOLUTIONS FOR EMBEDDED WORLD ...making it simple

If you want to learn more about our products, please visit our website at [www.mikroe.com](http://www.mikroe.com)

If you are experiencing some problems with any of our products or just need additional information, please place your ticket at [www.mikroe.com/en/support](http://www.mikroe.com/en/support)

If you have any questions, comments or business proposals, do not hesitate to contact us at [office@mikroe.com](mailto:office@mikroe.com)