

TOP VIEW

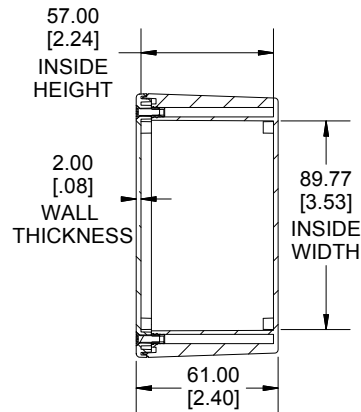

**SECTION B-B
END VIEW**

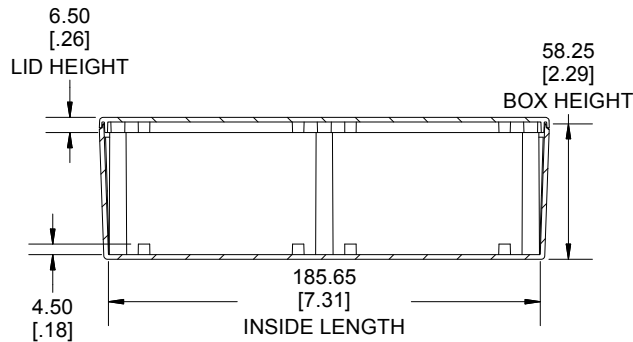

**SECTION A-A
SIDE VIEW**

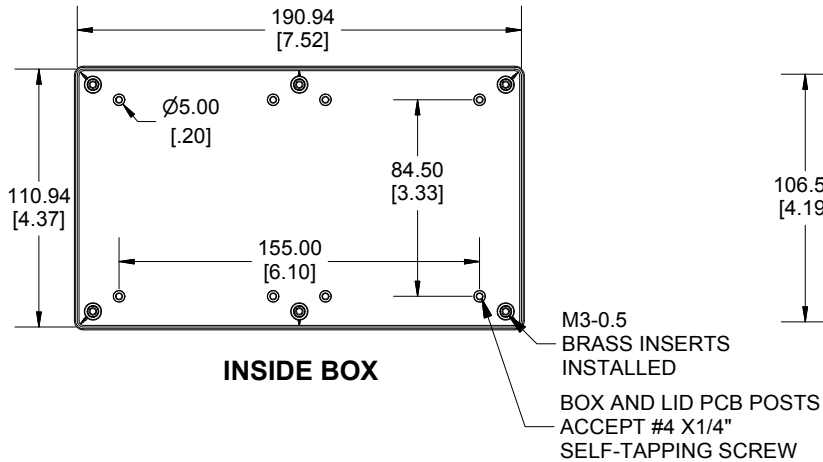
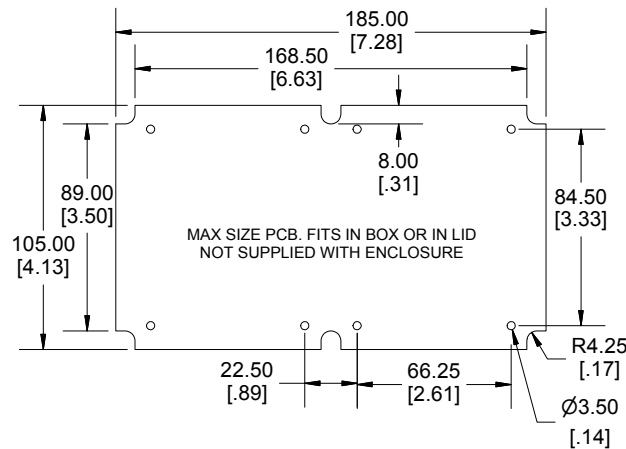

INSIDE BOX

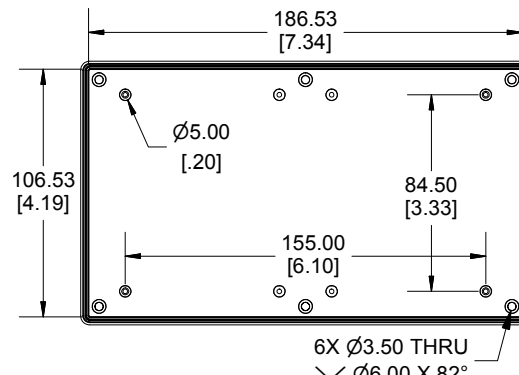

INSIDE LID

Enclosures can be Factory Modified (Milling, Drilling, Printing etc.)
 Contact Factory mjm@hammondmfg.com for quotes
 Solid models of this enclosure available in STEP or IGES.
 (Part number and text placement/orientation on our products are subject to change,
 we do not recommend using them as a locating reference for modification purposes)

NOTE	
Purchased assembly includes box, lid, 6 cover screws and installed brass inserts.	
Enclosure molded from FRABS UL 94-V0 Plastic.	
Other materials / colours available consult factory.	
Recommended Torque : (43-50) Ozf.in / (30-35) cNm	

PART NUMBERS	
1591XXE Enclosure	
Black Textured Enclosure	1591XXEBK
Gray Textured Enclosure	1591XXEGY
ACCESSORIES	
Black Cover Screws [M3-0.5 X10mm]	1591MS100BK (Pkg 100)
Plated Cover Screws [M3-0.5 X10mm]	1591MS100 (Pkg 100)
P.C. Board Screws	1593ATS60 (Pkg 50)
[#4 x 1/4" self-tapping (6.4mm)]	1593ATS100 (Pkg 100)

**HAMMOND
MANUFACTURING®**

1591XXE

www.hammondmfg.com

Dimensions:
 mm
 [inches]