

TPS61043 Constant Current LED Driver

1 Features

- Current Source With 18-V Overvoltage Protection
- Powers up to 4 LEDs in Series
- Input Voltage Range: 1.8 V to 6 V
- Internal 30-V Switch
- Up to 85% Efficiency
- Precise Brightness Control Using PWM Signal or Analog Signal
- Switching Frequency up to 1 MHz
- Internal Power MOSFET Switch 400 mA
- Operates With Small Output Capacitors Down to 100 nF
- Disconnects LEDs During Shutdown
- No Load Quiescent Current 38 μ A Typical
- Shutdown Current 0.1 μ A Typical
- Available in a Small 3-mm \times 3-mm QFN Package

2 Applications

- White LED Supply for Display Backlight and Sidelight
 - PDAs, Pocket PCs, Smart Phones
 - Handheld Devices
 - Cellular Phones

3 Description

The TPS61043 is a high-frequency boost converter with constant current output that drives white LEDs or similar. The LED current is set with the external sense resistor (R_S) and is directly regulated by the feedback pin (FB) that regulates the voltage across the sense resistor R_S to 252 mV (typical). To control LED brightness, the LED current can be pulsed by applying a PWM (pulse width modulated) signal with a frequency range of 100 Hz to 50 kHz to the control pin (CTRL). To allow higher flexibility, the device can be configured so that the brightness is controlled by an analog signal as well, as described in [Application Information](#). To avoid possible leakage currents through the LEDs during shutdown, the control pin (CTRL) disables the device and disconnects the LEDs from ground. For maximum safety during operation, the output has integrated overvoltage protection that prevents damage to the device by limiting the output voltage to typically 18 V in case of a high-impedance output (for example, faulty LED). The TPS61043 device provides a solution for applications where higher LED currents or more than four LEDs in series must be powered.

Device Information⁽¹⁾

PART NUMBER	PACKAGE	BODY SIZE (NOM)
TPS61043	VSON (8)	3.00 mm \times 3.00 mm

(1) For all available packages, see the orderable addendum at the end of the data sheet.

Typical Application

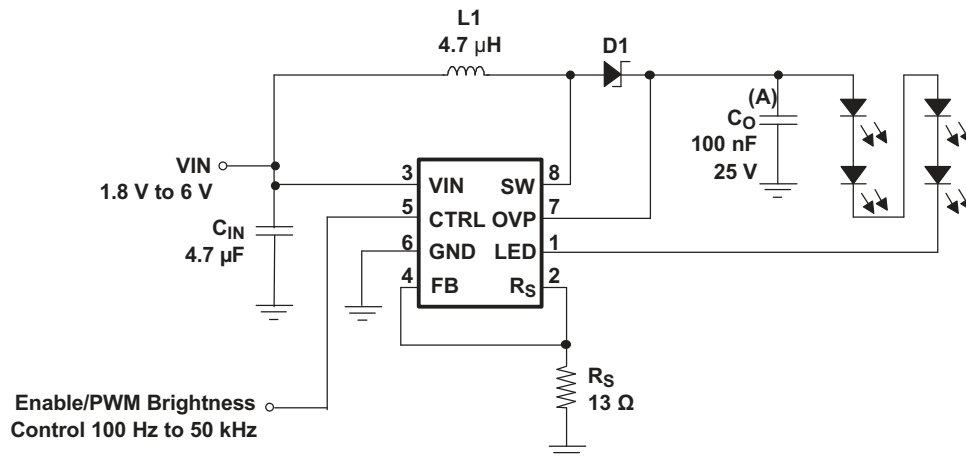

(A) Output capacitor values like 1 μ F and larger, reduce the LED ripple current and improve line regulation.



Table of Contents

1 Features	1	9 Application and Implementation	12
2 Applications	1	9.1 Application Information.....	12
3 Description	1	9.2 Typical Application	15
4 Revision History	2	9.3 System Examples	19
5 Pin Configuration and Functions	3	10 Power Supply Recommendations	22
6 Specifications	3	11 Layout	22
6.1 Absolute Maximum Ratings	3	11.1 Layout Guidelines	22
6.2 ESD Ratings.....	4	11.2 Layout Example	22
6.3 Recommended Operating Conditions.....	4	11.3 Thermal Considerations	22
6.4 Thermal Information	4	12 Device and Documentation Support	23
6.5 Electrical Characteristics.....	4	12.1 Device Support.....	23
6.6 Typical Characteristics	6	12.2 Documentation Support	23
7 Parameter Measurement Information	7	12.3 Community Resources.....	23
8 Detailed Description	8	12.4 Trademarks	23
8.1 Overview	8	12.5 Electrostatic Discharge Caution.....	23
8.2 Functional Block Diagram	8	12.6 Glossary	23
8.3 Feature Description.....	9	13 Mechanical, Packaging, and Orderable Information	23
8.4 Device Functional Modes.....	10		

4 Revision History

Changes from Revision B (May 2015) to Revision C	Page
• Changed image object in Figure 25 .	22
• Added Community Resources section.	23

Changes from Revision A (December 2003) to Revision B	Page
• Added <i>Pin Configuration and Functions</i> section, <i>ESD Ratings</i> table, <i>Feature Description</i> section, <i>Device Functional Modes</i> , <i>Application and Implementation</i> section, <i>Power Supply Recommendations</i> section, <i>Layout</i> section, <i>Device and Documentation Support</i> section, and <i>Mechanical, Packaging, and Orderable Information</i> section	1

5 Pin Configuration and Functions

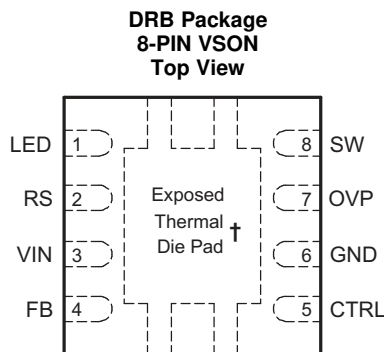

† The exposed thermal die pad is connected to GND.

Pin Functions

PIN		I/O	DESCRIPTION
NAME	NO.		
CTRL	5	I	Combined enable and PWM control pin. If CTRL is constantly pulled high, the device is enabled and the internal LED switch (Q2) is constantly turned on. When CTRL is pulled to GND, the device is disabled. Apply a PWM signal (100 Hz to 50 kHz) to this pin to control the brightness of the LEDs
FB	4	I	Feedback. FB regulates the LED current through the sense resistor by regulating the voltage across R_S to 252 mV.
GND	6		GND
LED	1	I	Input of the LED switch (Q2). Connect the LEDs to this pin.
OVP	7	I	Overshoot protection. OVP is connected to the output capacitor of the converter.
RS	2	O	Output of the internal LED switch. The sense resistor that programs the LED current is connected to RS.
SW	8	I	Drain of the integrated switch (Q1)
VIN	3	I	Input supply pin.

6 Specifications

6.1 Absolute Maximum Ratings

over operating free-air temperature range (unless otherwise noted)⁽¹⁾

	MIN	MAX	UNIT
Supply Voltages, $v_{(VIN)}$ ⁽²⁾	-0.3	7	V
Voltages, $V_{(RS)}$, $V_{(CTRL)}$, $V_{(FB)}$	-0.3	$V_{in} + 0.3$	V
Voltages, $V_{(SW)}$, $V_{(LED)}$ ⁽²⁾		30	V
Voltage, $V_{(OVP)}$		30	V
Operating junction temperature	-40	150	°C
Lead temperature (soldering, 10 sec)	260	260	°C
Storage temperature, T_{stg}	-65	150	°C

- (1) Stresses beyond those listed under *Absolute Maximum Ratings* may cause permanent damage to the device. These are stress ratings only, which do not imply functional operation of the device at these or any other conditions beyond those indicated under *Recommended Operating Conditions*. Exposure to absolute-maximum-rated conditions for extended periods may affect device reliability.
- (2) All voltage values are with respect to network ground terminal.

6.2 ESD Ratings

		VALUE	UNIT
V _(ESD)	Electrostatic discharge	Human body model (HBM), per ANSI/ESDA/JEDEC JS-001 ⁽¹⁾	±2000
		Charged-device model (CDM), per JEDEC specification JESD22-C101 ⁽²⁾	±750
			V

(1) JEDEC document JEP155 states that 500-V HBM allows safe manufacturing with a standard ESD control process.

(2) JEDEC document JEP157 states that 250-V CDM allows safe manufacturing with a standard ESD control process.

6.3 Recommended Operating Conditions

		MIN	NOM	MAX	UNIT
V _I	Input voltage	1.8		6	V
T _A	Operating ambient temperature	–40		85	°C
T _J	Operating junction temperature	–40		125	°C

6.4 Thermal Information

THERMAL METRIC ⁽¹⁾		TPS61043	UNIT
		DRB (VSON)	
		8 PINS	
R _{θJA}	Junction-to-ambient thermal resistance	48.6	°C/W
R _{θJC(top)}	Junction-to-case (top) thermal resistance	66.9	°C/W
R _{θJB}	Junction-to-board thermal resistance	23.8	°C/W
Ψ _{JT}	Junction-to-top characterization parameter	1.5	°C/W
Ψ _{JB}	Junction-to-board characterization parameter	23.9	°C/W
R _{θJC(bot)}	Junction-to-case (bottom) thermal resistance	5.2	°C/W

(1) For more information about traditional and new thermal metrics, see the *IC Package Thermal Metrics* application report, [SPRA953](#).

6.5 Electrical Characteristics

V_I = 3.6 V, CTRL = V_I, T_A = –40°C to +85°C, typical values are at T_A = 25°C (unless otherwise noted)

PARAMETER		TEST CONDITIONS	MIN	TYP	MAX	UNIT
SUPPLY CURRENT						
V _I	Input voltage range		1.8		6	V
I _(Q)	Operating quiescent current into VIN	I _O = 0 mA, not switching		38	65	μA
I _{O(sd)}	Shutdown current	CTRL = GND		0.1	1	μA
V _{UVLO}	Under-voltage lockout threshold	V _I falling		1.5	1.7	V
CTRL						
V _{IH}	CTRL high level input voltage		1.3			V
V _{IL}	CTRL low level input voltage				0.3	V
I _{lkg}	CTRL input leakage current	CTRL = GND or VIN			0.1	μA
t _{on}	Minimum CTRL pulse width to enable	CTRL = low to high	500			us
t _{off}	Minimum CTRL pulse width to disable	CTRL = high to low	10		32	ms
f _(CTRL)	PWM switching frequency applied to CTRL		0.1		50	kHz
D _(CTRL)	PWM duty cycle applied to CTRL		1%		100%	
POWER SWITCH AND CURRENT LIMIT (SW)						
V _S	Maximum switch voltage				30	V
r _{ds(ON)}	MOSFET ON-resistance	V _I = 3.6 V; I _(SW) = 200 mA		300	600	mΩ
I _{lkg}	MOSFET leakage current	V _(SW) = 28 V		0.1	10	μA
I _{LIM}	MOSFET current limit		320	400	480	mA
T _{ON}	Power switch maximum on-time	V _O = 15 V		4.5		μs
T _{OFF}	Power switch minimum off-time			400		ns

Electrical Characteristics (continued)
 $V_I = 3.6\text{ V}$, CTRL = V_I , $T_A = -40^\circ\text{C}$ to $+85^\circ\text{C}$, typical values are at $T_A = 25^\circ\text{C}$ (unless otherwise noted)

PARAMETER		TEST CONDITIONS	MIN	TYP	MAX	UNIT
LED SWITCH AND CURRENT LIMIT (LED)						
V_S	Maximum switch voltage				30	V
$I_{(LED)}$	Maximum LED switch current				60	mA
$r_{ds(ON)}$	MOSFET ON-resistance	$V_I = 3.6\text{ V}$; $I_{SW} = 20\text{ mA}$		1	2	Ω
I_{lkg}	MOSFET leakage current	$V_{(LED)} = 28\text{ V}$		0.1	10	μA
OUTPUT						
V_O	Output voltage range	OVP connected	V_I		16.9	V
$I_{(FB)}$	Feedback input bias current ⁽¹⁾	$V_{(FB)} = 0.252\text{ V}$			100	nA
V_{FB}	Feedback trip point voltage	$1.8\text{ V} \leq V_I \leq 6.0\text{ V}$	244	252	260	mV
$V_{(OVP)}$	Output overvoltage protection	V_O rising	17	18	19	V
$V_{hys(OVP)}$	Output overvoltage protection hysteresis			3.65		V
$I_{(OVP)}$	OVP input current	$V_O = 15\text{ V}$		17	23	μA

(1) The feedback input is high-impedance MOSFET Gate input.

6.6 Typical Characteristics

Table 1. Table of Graphs

			FIGURE
$V_{(FB)}$	Feedback voltage	vs Temperature	Figure 1
$I_{(FB)}$	Feedback current	vs Temperature	Figure 2
$r_{ds(on)}$	Main switch Q1	vs Temperature	Figure 3
		vs Input voltage	Figure 4
	LED switch Q2	vs Temperature	Figure 5
		vs Input voltage	Figure 6
I_{LED}	Average LED current	vs PWM duty cycle on CTRL pin	Figure 7

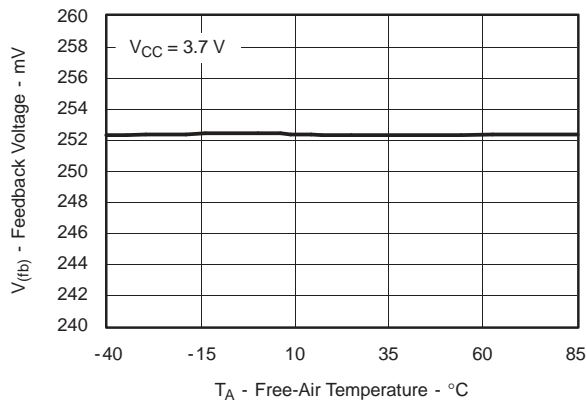

Figure 1. Feedback Voltage vs Temperature

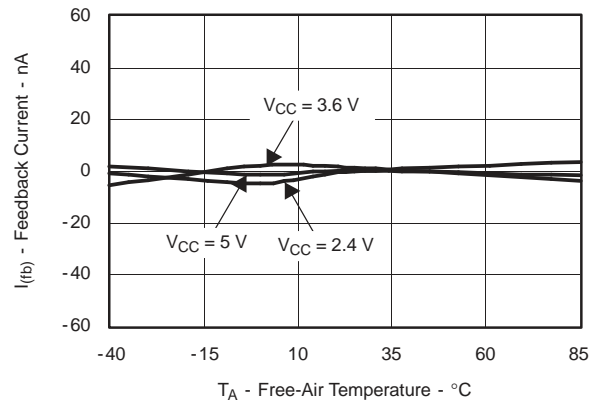

Figure 2. Feedback Current vs Temperature

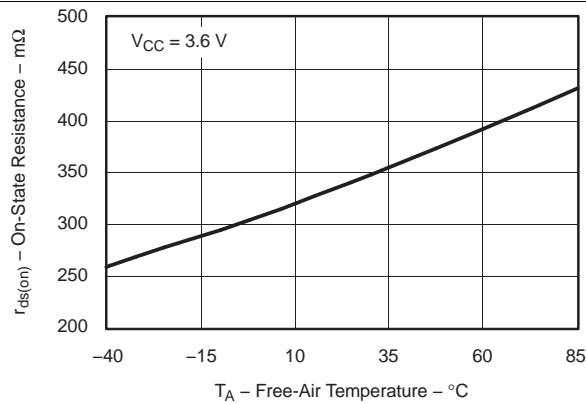

Figure 3. $r_{ds(on)}$ Main Switch (Q1) vs Temperature

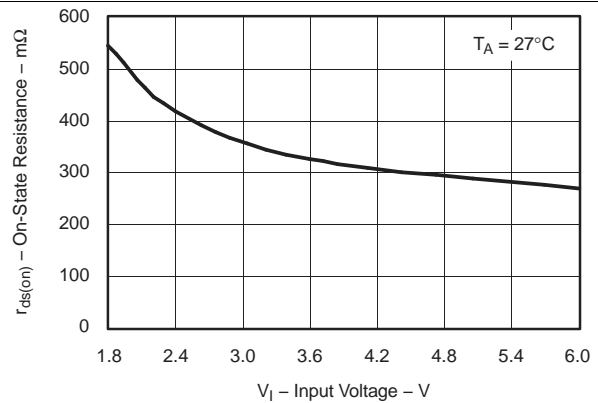

Figure 4. $r_{ds(ON)}$ Main Switch (Q1) vs Input Voltage

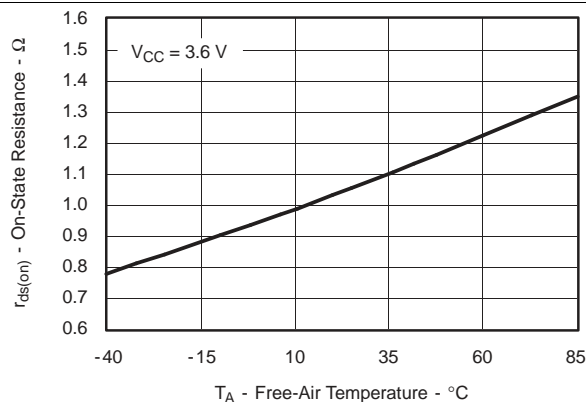

Figure 5. $r_{ds(on)}$ LED Switch (Q2) vs Temperature

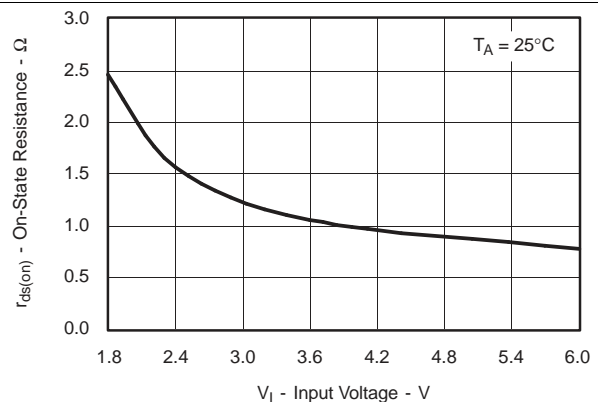

Figure 6. $r_{ds(on)}$ LED Switch (Q2) vs Input Voltage

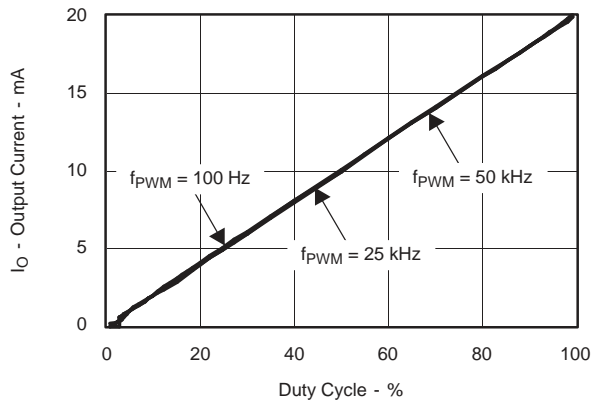

Figure 7. Average LED Current vs PWM Duty Cycle on CTRL Pin

7 Parameter Measurement Information

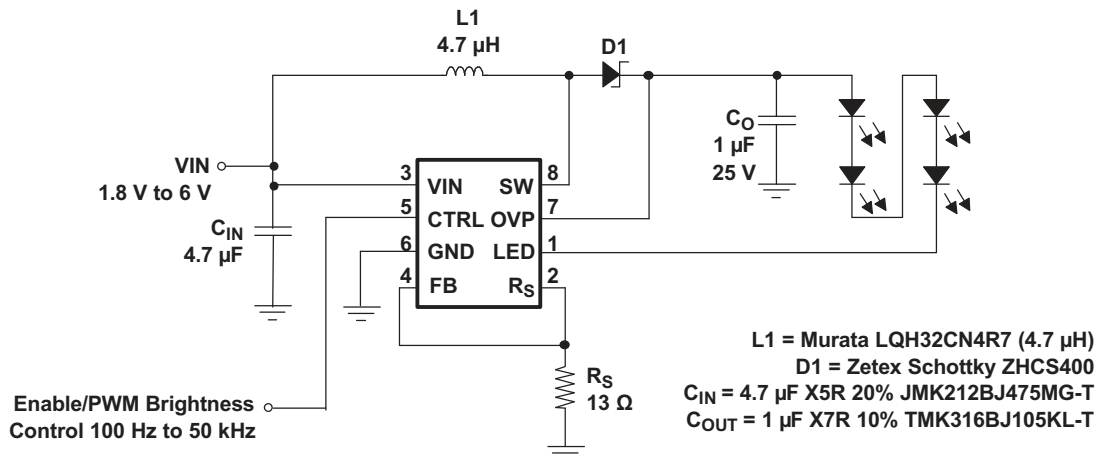

Figure 8. Schematic

8 Detailed Description

8.1 Overview

The TPS61043 operates like a standard boost converter but regulates the voltage across the sense resistor (RS) instead of the output voltage. This gives an accurate regulated LED current independent of the input voltage and number of LEDs connected. With integrated overvoltage protection (OVP) the TPS61043 is configured as a current source with overvoltage protection ideally suited to drive LEDs. The device can generate output voltages of up to 18 V and has an internal 400mA MOSFET switch (Q1). This allows several LEDs to be connected in series to the output. The internal LED switch (Q2) in series with the LEDs has a maximum current rating of 60 mA and disconnects the LEDs from ground during shutdown. The LED switch is driven by a PWM signal applied to the control pin (CTRL), which directly controls the LED brightness. With this control method the LED brightness depends on the PWM duty cycle only and is independent of the PWM frequency and amplitude.

8.2 Functional Block Diagram

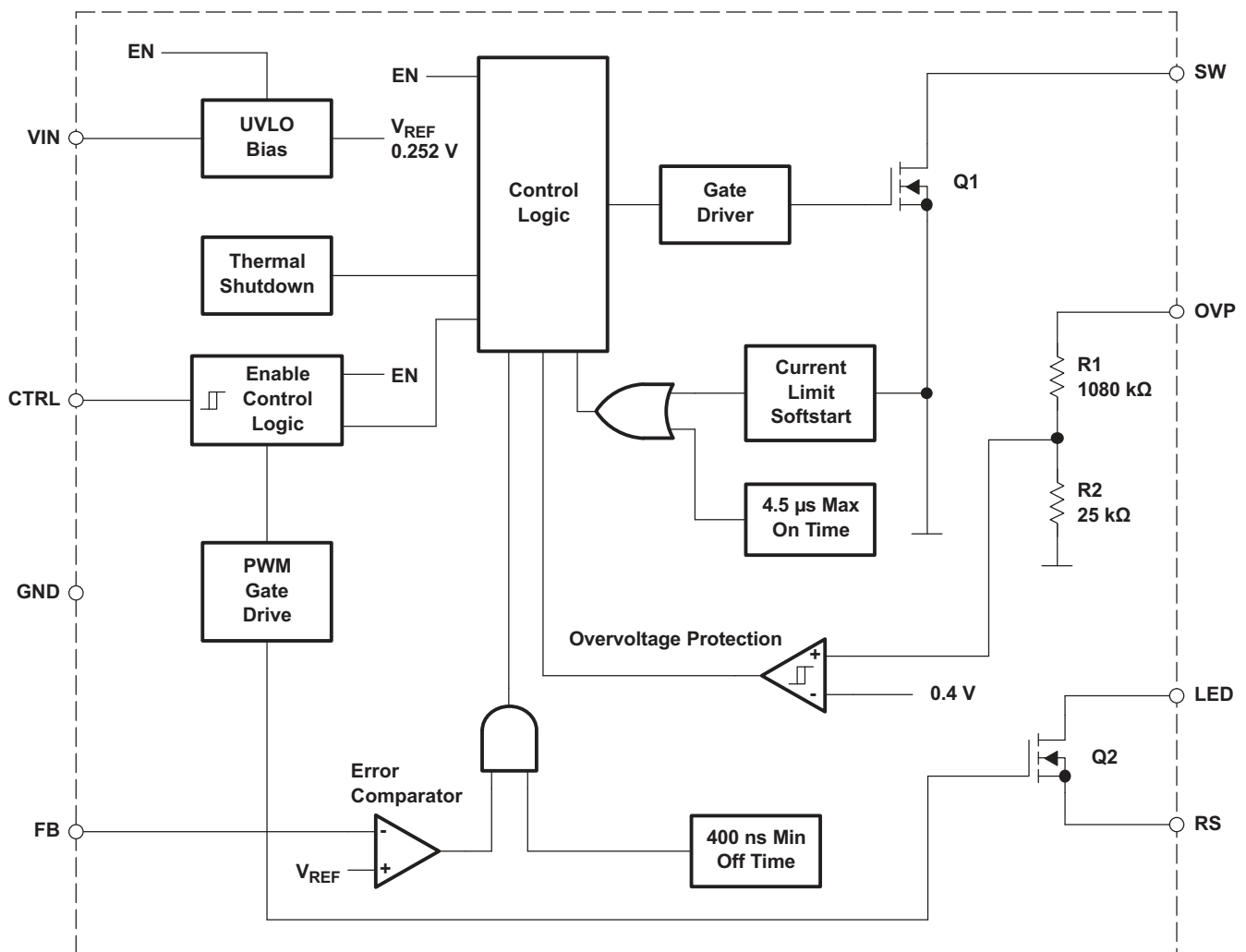

8.3 Feature Description

8.3.1 Operation

The TPS61043 operates like a standard boost converter but regulates the voltage across the sense resistor (R_S) instead of the output voltage. This gives an accurate regulated LED current independent of the input voltage and number of LEDs connected. With integrated overvoltage protection (OVP) the TPS61043 is configured as a current source with overvoltage protection ideally suited to drive LEDs. The device can generate output voltages of up to 16.9 V if the OVP-function is used and has an internal 400 mA MOSFET switch (Q1). This allows up to four LEDs to be connected in series to the output. The internal LED switch (Q2) in series with the LEDs has a maximum current rating of 60 mA and disconnects the LEDs from ground during shutdown. The LED switch is driven by a PWM signal applied to the control pin (CTRL), which directly controls the LED brightness. With this control method the LED brightness depends on the PWM duty cycle only and is independent of the PWM frequency and amplitude. If the OVP-function is not needed, the device can be used to generate output voltages up to 28V.

8.3.2 Boost Converter

The boost converter operates in a pulse frequency modulation (PFM) scheme with constant peak current control. This control scheme maintains high efficiency over the entire load current range and with a switching frequency of up to 1 MHz, enables the use of small external components. The converter monitors the sense voltage across R_S with the feedback pin (FB) and, when the feedback voltage falls below the reference voltage (252 mV typ), the main switch turns on and the current ramps up. The main switch turns off when the inductor current reaches the internally set peak current of 400 mA (typ). Refer to the [Peak Current Control \(Boost Converter\)](#) section for more information. The second criteria that turns off the main switch is the maximum on-time of 4.5 μ s (typ). This limits the maximum on-time of the converter in extreme conditions. As the switch is turned off the external Schottky diode is forward biased, delivering the stored inductor energy to the output. The main switch remains off until the minimum off time of 400 ns (typ) has passed and the feedback voltage is below the reference voltage again. Using this PFM peak current control scheme, the converter operates in discontinuous conduction mode (DCM) where the switching frequency depends on the inductor, input and output voltage, and LED current. Lower LED currents reduce the switching frequency, which results in high efficiency over the entire LED current range. This regulation scheme is inherently stable, allowing a wide range for the selection of the inductor and output capacitor.

8.3.3 Peak Current Control (Boost Converter)

The internal switch is turned on until the inductor current reaches the DC current limit (I_{LIM}) of 400 mA (typ). Due to the internal current limit delay of 100 ns (typ) the actual current exceeds the DC current limit threshold by a small amount. The typical peak current limit can be calculated:

$$I_{P(typ)} = I_{(LIM)} + \frac{V_I}{L} \times 100 \text{ ns} \quad (1)$$

$$I_P = 400\text{mA} + \frac{V_I}{L} \times 100\text{ns} \quad (2)$$

The higher the input voltage and the lower the inductor value, the greater the current limit overshoot.

8.3.4 Softstart

All inductive step-up converters exhibit high in-rush current during start-up if no special precautions are taken. This can cause voltage drops at the input rail during start-up, which may result in an unwanted or premature system shutdown.

The TPS61043 limits this in-rush current during start-up by increasing the current limit in two steps starting from $I_{LIM}/4$ for 256 switch cycles to $I_{LIM}/2$ for the next 256 switch cycles and then full current limit. See [Figure 16](#) for typical start-up behavior.

Feature Description (continued)

8.3.5 Control (CTRL)

The CTRL pin serves two functions. One is the enable and disable of the device. The other is the PWM control of the internal LED switch (Q2). The CTRL pin can be used as a standard enable pin for the device if no PWM signal is applied to the CTRL pin. To enable the device, the CTRL pin must be pulled high for a time period of at least 500 μ s. The device starts with the Softstart cycle. Pulling the CTRL pin to GND for a time period \geq 32 ms disables the device, disconnecting the LEDs from GND by opening the LED switch (Q2) to avoid any LED leakage current. See [Figure 9](#) for the CTRL pin timing.

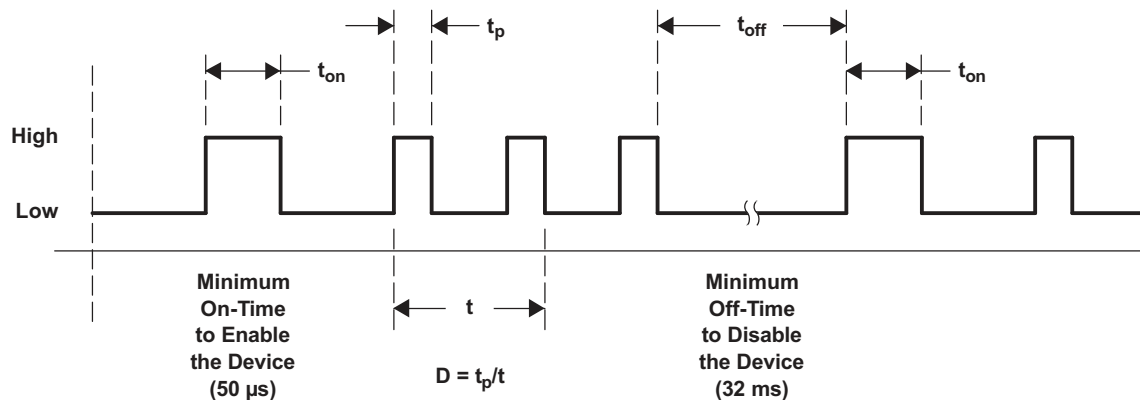

Figure 9. CTRL Timing Diagram

To enable the device, the CTRL signal must be high for 500 μ s (see [Figure 9](#)). The PWM signal can then be applied with a pulse width (t_p) greater or smaller than t_{ON} . To force the device into shutdown mode, the CTRL signal must be low for at least 32 ms. Requiring the CTRL pin to be low for 32 ms before the device enters shutdown allows for PWM dimming frequencies as low as 100 Hz. The device is enabled again when a CTRL signal is high for a period of 500 μ s minimum. See [Figure 7](#) for the PWM duty cycle versus LED current characteristic.

The internal LED switch (Q2) is driven by the PWM signal when applied to the CTRL pin. Applying a PWM signal in the range of 100 Hz to 50 kHz allows the LED current to be pulsed with the duty cycle of the PWM signal. The CTRL pin accepts a PWM duty cycle from $D = 1\%$ to 100%. Duty cycles below 1% are also possible with the restriction that the device is forced into shutdown as the off time of the applied PWM signal exceeds 10 ms.

When a PWM signal is applied to the CTRL pin the LED switch (Q2) turns on immediately. The internal error comparator is disabled for 400 ns. This 400 ns delay time is required to establish the correct voltage level across the sense resistor R_s after the LED switch (Q2) is closed.

To achieve good LED current accuracy and linearity, the switching frequency of the converter must be higher than the PWM frequency applied to the CTRL pin. This CTRL pin must be terminated.

8.4 Device Functional Modes

8.4.1 Overvoltage Protection (OVP)

As with any current source, the output voltage rises as the output impedance increases as for example with a disconnected load. To prevent the output voltage from exceeding the maximum main switch (Q1) voltage rating, an overvoltage protection (OVP) circuit is integrated. With an OVP threshold voltage of 19 V maximum, up to 4 LEDs can be connected in series. This allows the use of a cheaper output capacitor with a 25 V voltage rating. When the output voltage exceeds the OVP threshold voltage, (Q1) turns off. The converter switch remains off until the output voltage falls below the OVP threshold voltage. As long as the output voltage is below the OVP threshold the converter continues its normal operation, until the output voltage exceeds the OVP threshold again. If overvoltage protection is not needed, then the OVP pin should be connected to GND. In this case the TPS61043 can be used to generate output voltages up to 28 V.

Device Functional Modes (continued)

8.4.2 Undervoltage Lockout

An undervoltage lockout feature prevents mis-operation of the device at input voltages below 1.5 V (typical). As long as the input voltage is below the undervoltage threshold the device remains off, with the main MOSFET switch (Q1) and the LED switch (Q2) open.

8.4.3 Thermal Shutdown

An internal thermal shutdown is implemented in the TPS61043 that shuts down the device if the typical junction temperature of 160°C is exceeded. If the device is in thermal shutdown mode, the main MOSFET switch (Q1) and the LED switch (Q2) are open.

9 Application and Implementation

NOTE

Information in the following applications sections is not part of the TI component specification, and TI does not warrant its accuracy or completeness. TI's customers are responsible for determining suitability of components for their purposes. Customers should validate and test their design implementation to confirm system functionality.

9.1 Application Information

Table 2. Possible Diodes (or Equivalent)

COMPONENT SUPPLIER	REVERSE VOLTAGE
ON Semiconductor MBR0530	30 V
ON Semiconductor MBR0520	20 V
Toshiba CRS02	30 V
Zetex ZHCS400	40 V

9.1.1 Efficiency

The overall efficiency of the application depends on the specific application conditions and mainly on the selection of the inductor. A lower inductor value increases the switching frequency and switching losses yielding in a lower efficiency. A lower inductor dc resistance has lower copper losses, giving a higher efficiency. Therefore, the efficiency can typically vary $\pm 5\%$ depending on the selected inductor. and can be used as a guideline for the application efficiency. These curves show the typical efficiency powering four LEDs using a 4.7- μH inductor with just 1,2 mm height. The efficiency curve in and show the efficiency delivering the power to the LEDs rather than the overall converter efficiency and is calculated as:

$$\eta = \frac{V_{\text{LED}} \times I_{\text{LED}}}{V_{\text{I}} \times I_{\text{I}}} \quad (3)$$

9.1.2 Setting the LED Current

The converter regulates the LED current by regulating the voltage across the current sense resistor (R_{S}). The voltage across the sense resistor is regulated to the internal reference voltage of $V_{(\text{FB})} = 252 \text{ mV}$.

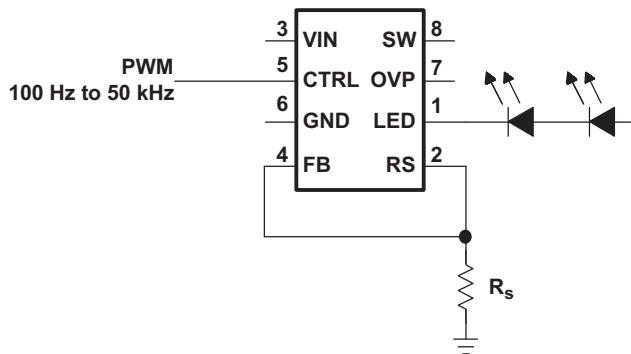

Figure 10. Setting the LED Current

The LED current can be calculated:

$$I_{\text{LED}} = \frac{V_{\text{FB}}}{R_{\text{S}}} = \frac{0.252\text{V}}{R_{\text{S}}} \quad (4)$$

9.1.4 PWM Control With Separate Enable

The control pin (CTRL) combines the enable function as well as the PWM brightness control function in one pin. For some systems an independent enable function is required. One way to implement this is to use the brightness control configuration as shown in the previous section [Figure 11](#).

Other possible solutions are shown in [Figure 12](#), [Figure 13](#), [Figure 14](#).

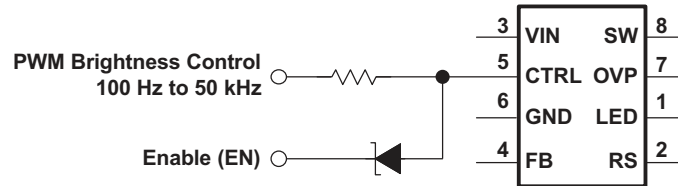

Figure 12. Separate Enable and PWM Control Using a Schottky Diode

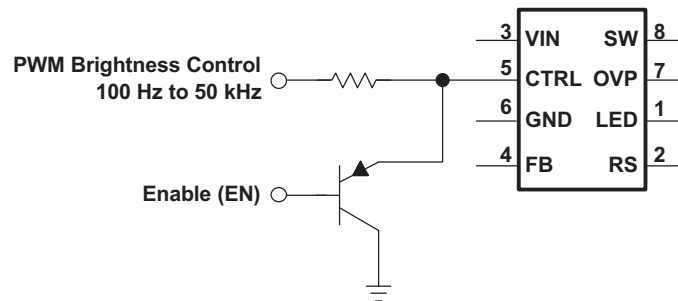

Figure 13. Separate Enable and PWM Control Using a Transistor

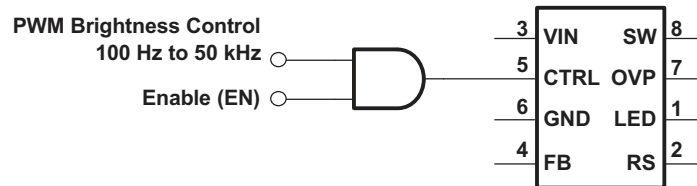
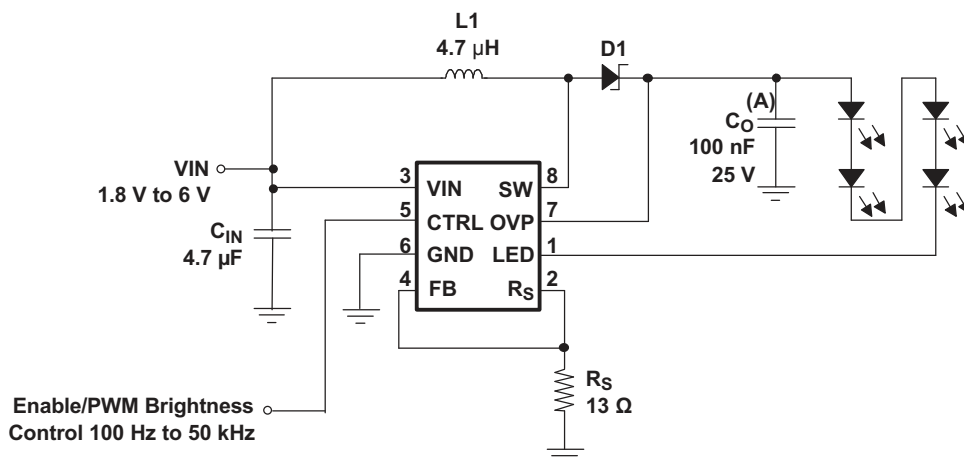

Figure 14. Separate Enable and PWM Control Using an AND Gate

9.2 Typical Application



(A) Output capacitor values like 1 μF and larger, reduce the LED ripple current and improve line regulation.

Figure 15. Typical Application Schematic

9.2.1 Design Requirements

For this design example, use the parameters listed in Table 3 as the input parameters.

Table 3. Design Parameters

DESIGN PARAMETER	TYPICAL VALUE
Input Voltage	1.8 V to 6 V
Output Voltage	V_{IN} to 16 V
Dimming frequency	0.1 to 50 kHz

9.2.2 Detailed Design Procedure

9.2.2.1 Inductor Selection, Maximum Load Current, and Switching Frequency

The PFM peak current control scheme of the TPS61043 is inherently stable. The inductor value does not affect the stability of the regulator. The selection of the inductor together with the nominal LED current, input, and output voltage of the application determines the switching frequency of the converter.

The first step is to calculate the maximum load current the converter can support using the selected inductor. The inductor value has less effect on the maximum available load current and is only of secondary order. A good inductor value to start with is 4.7 μH . Depending on the application, inductor values down to 1 μH can be used. The maximum inductor value is determined by the maximum on time of the switch of 4.5 μs (typical). The peak current limit of 400 mA (typical) must be reached within this 4.5 μs for proper operation. The maximum load current of the converter is determined at the operation point where the converter starts to enter the continuous conduction mode. The converter must always operate in discontinuous conduction mode to maintain regulation.

Depending on the time period of the inductor current fall time being larger or smaller compared to the minimum off time of the converter (400 ns typ), the maximum load current can be calculated.

Inductor fall time:

$$t_f = \frac{I_p \times L}{V_O - V_I}$$

where

- $t_f \geq 400 \text{ ns}$ (9)

$$I_{\text{LOAD(max)}} = \eta \times \frac{I_p \times V_I}{2 \times V_O} \quad (10)$$

$$I_{\text{LOAD(max)}} = \eta \times \frac{I_{\text{P}}^2 \times L \times V_{\text{I}}}{(V_{\text{O}} - V_{\text{I}}) \times (2 \times I_{\text{P}} \times L + 2 \times 400\text{ns} \times V_{\text{I}})}$$

where

- L = selected inductor value
- η = expected converter efficiency. Typically between 70% to 85% (11)

$$I_{\text{P}} = 400\text{mA} + \frac{V_{\text{I}}}{L} \times 100\text{ns} \quad (12)$$

(Peak inductor current as described in the [Peak Current Control \(Boost Converter\)](#) section)

The above formula contains the expected converter efficiency that allows calculating the expected maximum load current the converter can support. The efficiency can be taken out of the efficiency graphs shown in and or 80% can be used as an accurate estimation.

If the converter can support the desired LED current, the next step is to calculate the converter switching frequency at the operation point, which must be ≤ 1 MHz. Also the converter switching frequency should be much higher than the applied PWM frequency at the CTRL pin to avoid nonlinear brightness control. Assuming the converter shows no double pulses or pulse bursts ([Figure 17](#) and [Figure 18](#)) on the switch node (SW) the switching frequency at the operation point can be calculated as:

$$f_{\text{S}} = \frac{2 \times I_{\text{O}} \times (V_{\text{O}} - V_{\text{I}} + V_{\text{F}})}{\left(I_{\text{LIM}} + \frac{V_{\text{I}}}{L} \times 100 \text{ ns} \right)^2 \times L} \leq 1\text{MHz}$$

where

- I_{LIM} = minimum switch current limit (320 mA typical)
- L = selected inductor value
- I_{O} = nominal load or LED current
- V_{F} = Rectifier diode forward voltage (typically 0.3 V) (13)

The smaller the inductor value, the higher the switching frequency of the converter but the lower the efficiency. The selected inductor must have a saturation current that meets the maximum peak current of the converter as calculated in [Peak Current Control \(Boost Converter\)](#). Use the maximum value for I_{LIM} (480 mA) for this calculation. Another important inductor parameter is the DC resistance. The lower the DC resistance the higher the efficiency of the converter. See [Table 4](#) and [Figure 20](#) to [Figure 24](#) for a selection of inductors.

Table 4. Possible Inductors (or Equivalent)

INDUCTOR VALUE	COMPONENT SUPPLIER	SIZE
10 μH	muRata LQH43CN100K01	4.5 mm \times 3.2 mm \times 2.6 mm
4.7 μH	muRata LQH32CN4R7M11	3.2 mm \times 2.5 mm \times 2 mm
10 μH	Coilcraft DO1605T-103MX	5.5 mm \times 4.1 mm \times 1.8 mm
4.7 μH	Sumida CDRH3D16-4R7	3.8 mm \times 3.8 mm \times 1.8 mm
3.3 μH	Sumida CMD4D11-3R3	3.5 mm \times 5.3 mm \times 1.2 mm
4.7 μH	Sumida CMD4D11-4R7	3.5 mm \times 5.3 mm \times 1.2 mm
3.3 μH	Sumida CMD4D11-3R3	3.5 mm \times 5.3 mm \times 1.2 mm
4.7 μH	Coiltronics SD12-4R7	5.2 mm \times 5.2 mm \times 1.2 mm
3.3 μH	Coilcraft LPO1704-332M	6.6 mm \times 5.5 mm \times 1 mm
4.7 μH	Coilcraft LPO1704-472M	6.6 mm \times 5.5 mm \times 1 mm

9.2.2.2 Output Capacitor Selection and Line Regulation

For better output voltage filtering, a low ESR output capacitor is recommended. Ceramic capacitors have a low ESR value, but depending on the application, tantalum capacitors can be used.

The selection of the output capacitor value directly influences the output voltage ripple of the converter which also influences line regulation. The larger the output voltage ripple, the larger the line regulation, which means that the LED current changes if the input voltage changes. If a certain change in LED current gives a noticeable change in LED brightness, depends on the LED manufacturer and on the application. Applications requiring good line regulation $\leq 1\%/V$ (typ) must use output capacitor values $\geq 1 \mu\text{F}$.

See [Table 5](#) and [Figure 20](#) to [Figure 24](#) for the selection of the output capacitor.

Assuming the converter does not show double pulses or pulse bursts (see [Figure 17](#) and [Figure 18](#)) on the switch node (SW), the output voltage ripple is calculated as:

$$\Delta V_O = \frac{I_O}{C_O} \times \left[\frac{1}{f_s} - \frac{\left(I_{LIM(min)} + \frac{V_I}{L} \times 100 \text{ ns} \right) \times L}{V_O + V_F - V_I} \right] + I_P \times \text{ESR}$$

where

- $I_{LIM(min)}$ = minimum switch current limit (320 mA typical)
- L = selected inductor value
- I_O = nominal load current
- f_s = switching frequency at the nominal load current as calculated with [Equation 13](#).
- V_F = rectifier diode forward voltage (0.3 V typical)
- C_O = selected output capacitor
- ESR = output capacitor ESR value

(14)

9.2.2.3 Input Capacitor Selection

For good input voltage filtering, low ESR ceramic capacitors are recommended. A 4.7- μF ceramic input capacitor is sufficient for most applications. For better input voltage filtering the capacitor value can be increased. Refer to [Table 5](#) and [Figure 20](#) to [Figure 24](#) for input capacitor selection.

Table 5. Possible Input and Output Capacitors (or Equivalent)

CAPACITOR	VOLTAGE RATING	COMPONENT SUPPLIER	COMMENTS
4.7 $\mu\text{F}/\text{X5R}/0805$	6.3 V	Tayo Yuden JMK212BY475MG	C_I
10 $\mu\text{F}/\text{X5R}/0805$	6.3 V	Tayo Yuden JMK212BJ106MG	C_I
100 nF		Any	C_O
220 nF		Any	C_O
470 nF		Any	C_O
1.0 $\mu\text{F}/\text{X7R}/1206$	25 V	Tayo Yuden TMK316BJ105KL	C_O
1.0 $\mu\text{F}/\text{X7R}/1206$	35 V	Tayo Yuden GMK316BJ105KL	C_O
4.7 $\mu\text{F}/\text{X5R}/1210$	25 V	Tayo Yuden TMK325BJ475MG	C_O

9.2.2.4 Diode Selection

To achieve high efficiency a Schottky diode must be used. The current rating of the diode must meet the peak current rating of the converter as it is calculated in the *peak current control* section. Use the maximum value for I_{LIM} for this calculation. See [Table 6](#) and [Figure 20](#) to [Figure 24](#) for the Schottky diode selection.

Table 6. Possible Diodes (or Equivalent)

COMPONENT SUPPLIER	REVERSE VOLTAGE
ON Semiconductor MBR0530	30 V
ON Semiconductor MBR0520	20 V

Table 6. Possible Diodes (or Equivalent) (continued)

COMPONENT SUPPLIER	REVERSE VOLTAGE
Toshiba CRS02	30 V
Zetex ZHCS400	40 V

9.2.3 Application Curves

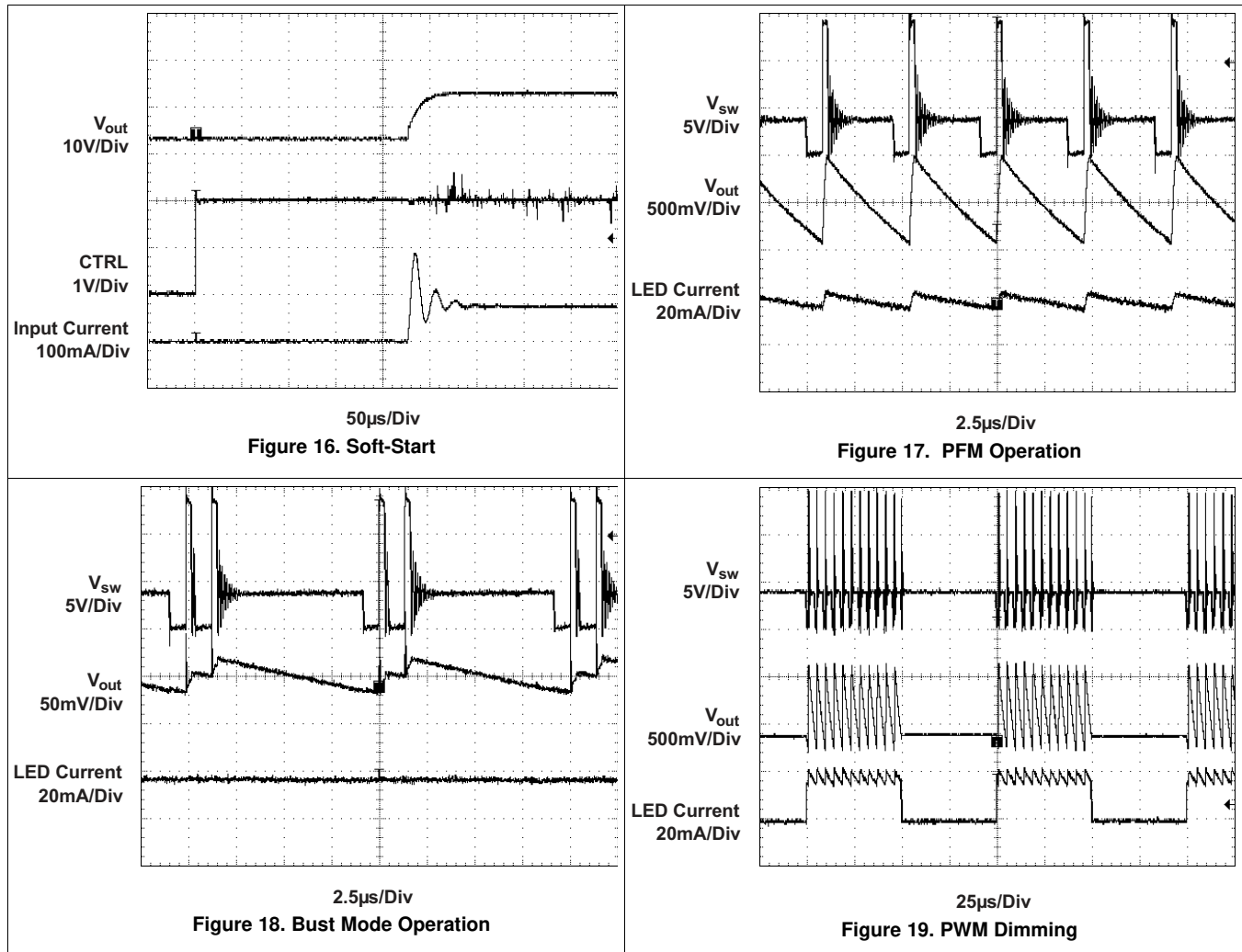

9.3 System Examples

9.3.1 TPS61043 With 1-mm Total System Height

TPS61043 is designed from 3 V to 6 V input for driving LED with 1-mm total system height.

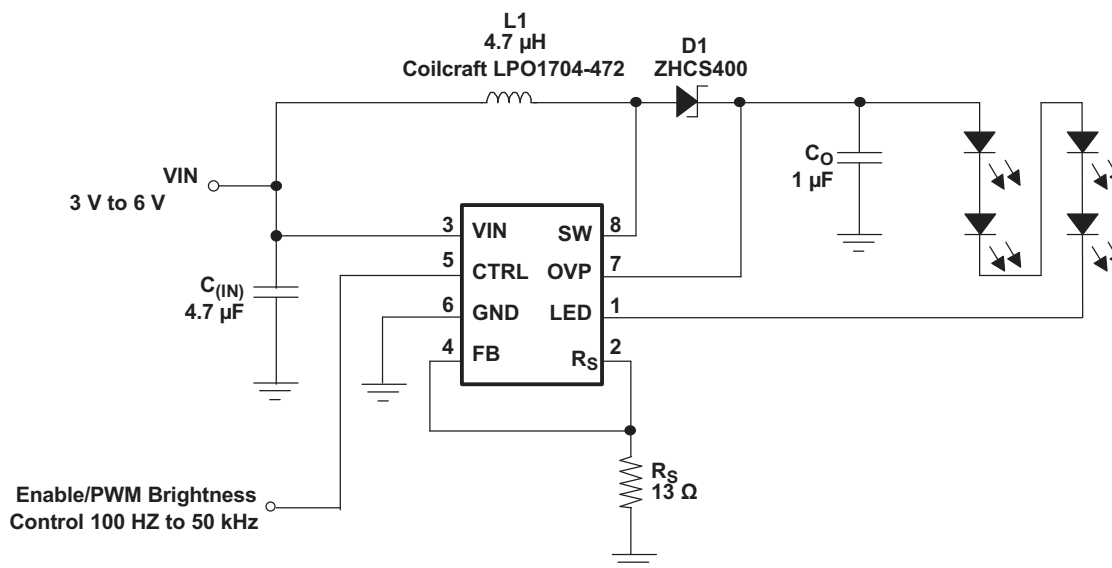

Figure 20. TPS61043 With 1-mm Total System Height

9.3.2 TPS61043 With Low LED Ripple Current and Higher Accuracy Using a 4.7-μF Output Capacitor

TPS61043 is designed from 3 V to 6 V input for driving LED with low LED ripple current and higher accuracy using a 4.7-μF output capacitor.

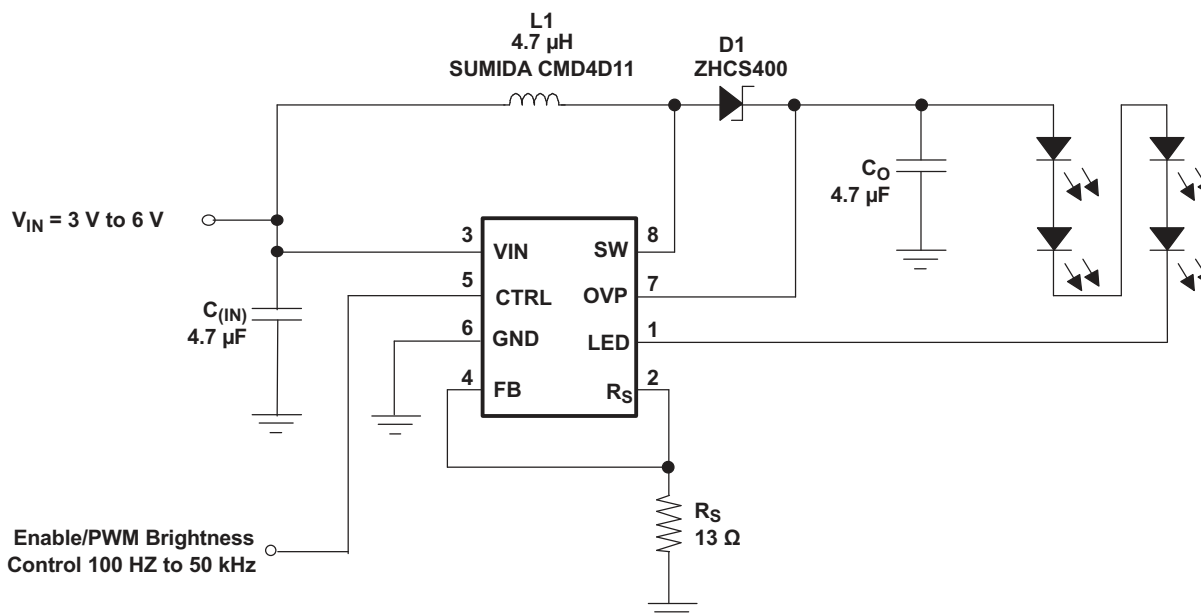

Figure 21. TPS61043 With Low LED Ripple Current and Higher Accuracy Using a 4.7-μF Output Capacitor

System Examples (continued)

9.3.3 TPS61043 Powering 3 LEDs

TPS61043 is designed from 3 V to 6 V input for driving 3 LEDs in series.

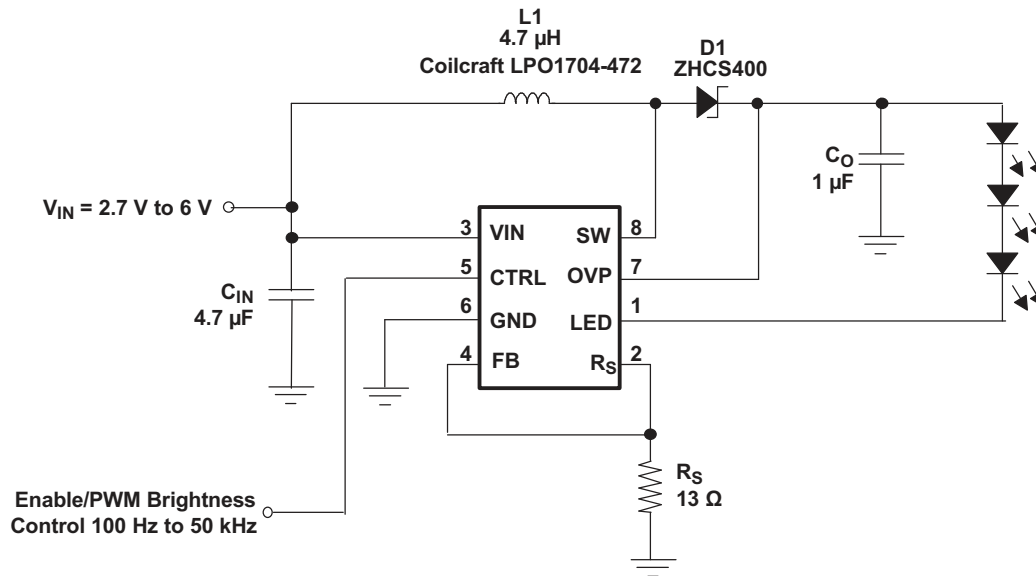

Figure 22. TPS61043 Powering 3 LEDs

9.3.4 Adjustable Brightness Control Using an Analog Voltage

TPS61043 is designed from 3 V to 6 V input for driving LED with adjustable brightness control using an analog voltage.

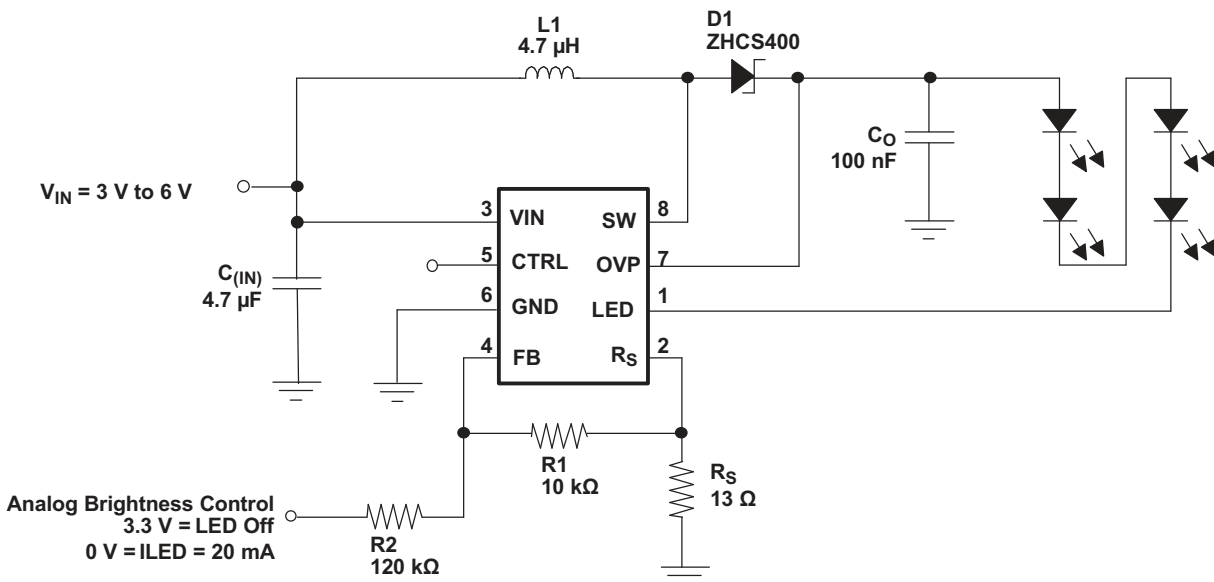

Figure 23. Adjustable Brightness Control Using an Analog Voltage

System Examples (continued)

9.3.5 Alternative Adjustable Brightness Control Using PWM Signal

TPS61043 is designed for driving LED with adjustable brightness control using an analog voltage.

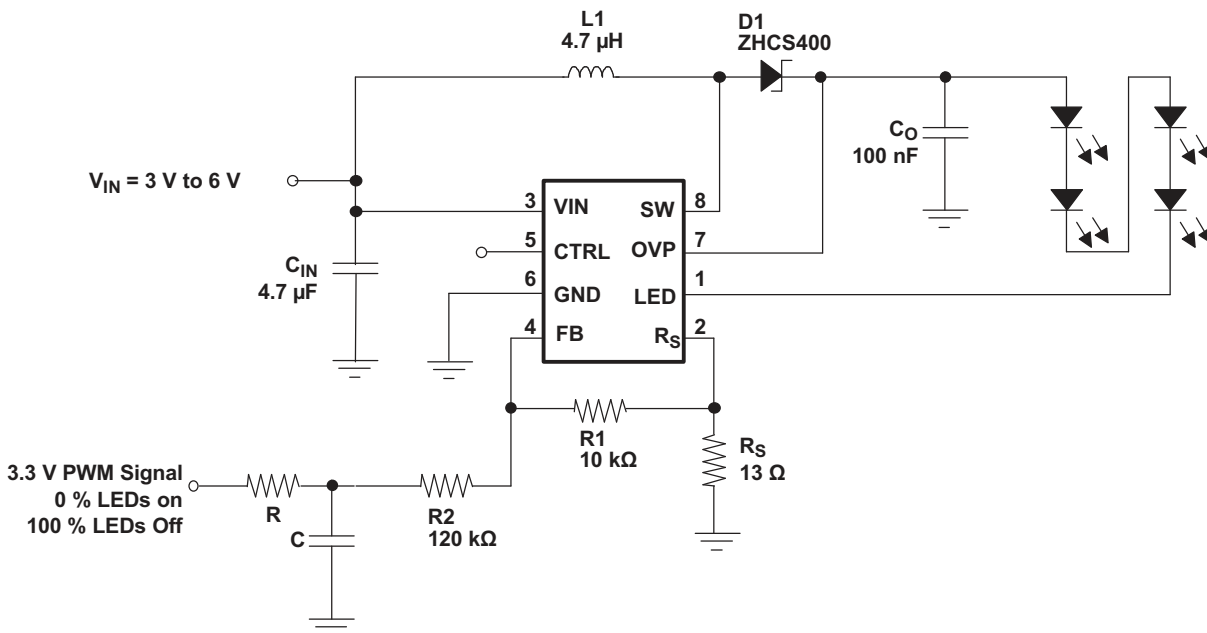

Figure 24. Alternative Adjustable Brightness Control Using PWM Signal

10 Power Supply Recommendations

The device is designed to operate from an input voltage supply range between 1.8 V and 6 V. The input power supply's output current needs to be rated according to the supply voltage, output voltage and output current of TPS61043.

11 Layout

11.1 Layout Guidelines

In all switching power supplies the layout is an important step in the design, especially at high peak currents and switching frequencies. If the layout is not carefully done, the regulator might show noise problems and duty cycle jitter.

The input capacitor should be placed as close as possible to the input pin for good input voltage filtering. The inductor and diode must be placed as close as possible to the switch pin to minimize noise coupling into other circuits. It is important to connect the output capacitor directly across the diode cathode pin and ground rather than connecting the output capacitor across the LEDs. This minimizes EMI. Because the feedback pin and network is a high-impedance circuit, the feedback network should be routed away from the inductor.

11.2 Layout Example

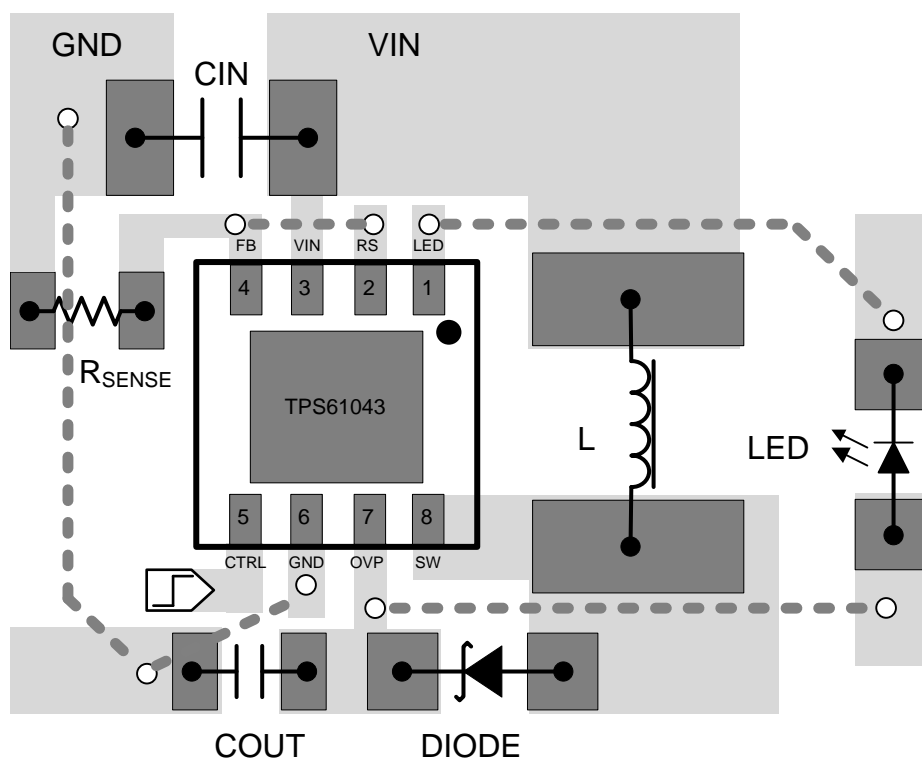

Figure 25. Layout Example

11.3 Thermal Considerations

The TPS61043 comes in a thermally enhanced QFN package. The package includes a thermal pad improving the thermal capabilities of the package. See *QFN/SON PCB Attachment (SLUA271)*.

The thermal resistance junction to ambient $R_{\Theta JA}$ of the QFN package greatly depends on the PCB layout. Using thermal vias and wide PCB traces improves the thermal resistance $R_{\Theta JA}$. Under normal operation conditions no PCB vias are required for the thermal pad. However, the thermal pad must be soldered to the PCB.

12 Device and Documentation Support

12.1 Device Support

12.1.1 Third-Party Products Disclaimer

TI'S PUBLICATION OF INFORMATION REGARDING THIRD-PARTY PRODUCTS OR SERVICES DOES NOT CONSTITUTE AN ENDORSEMENT REGARDING THE SUITABILITY OF SUCH PRODUCTS OR SERVICES OR A WARRANTY, REPRESENTATION OR ENDORSEMENT OF SUCH PRODUCTS OR SERVICES, EITHER ALONE OR IN COMBINATION WITH ANY TI PRODUCT OR SERVICE.

12.2 Documentation Support

12.2.1 Related Documentation

For related documentation see the following:

QFN/SON PCB Attachment, [SLUA271](#)

12.3 Community Resources

The following links connect to TI community resources. Linked contents are provided "AS IS" by the respective contributors. They do not constitute TI specifications and do not necessarily reflect TI's views; see TI's [Terms of Use](#).

TI E2E™ Online Community *TI's Engineer-to-Engineer (E2E) Community*. Created to foster collaboration among engineers. At [e2e.ti.com](#), you can ask questions, share knowledge, explore ideas and help solve problems with fellow engineers.

Design Support *TI's Design Support* Quickly find helpful E2E forums along with design support tools and contact information for technical support.

12.4 Trademarks

E2E is a trademark of Texas Instruments.
All other trademarks are the property of their respective owners.

12.5 Electrostatic Discharge Caution



These devices have limited built-in ESD protection. The leads should be shorted together or the device placed in conductive foam during storage or handling to prevent electrostatic damage to the MOS gates.

12.6 Glossary

[SLYZ022](#) — *TI Glossary*.

This glossary lists and explains terms, acronyms, and definitions.

13 Mechanical, Packaging, and Orderable Information

The following pages include mechanical, packaging, and orderable information. This information is the most current data available for the designated devices. This data is subject to change without notice and revision of this document. For browser-based versions of this data sheet, refer to the left-hand navigation.

PACKAGING INFORMATION

Orderable Device	Status (1)	Package Type	Package Drawing	Pins	Package Qty	Eco Plan (2)	Lead finish/ Ball material (6)	MSL Peak Temp (3)	Op Temp (°C)	Device Marking (4/5)	Samples
TPS61043DRBR	ACTIVE	SON	DRB	8	3000	RoHS & Green	NIPDAU	Level-2-260C-1 YEAR	-40 to 85	AQN	Samples
TPS61043DRBT	ACTIVE	SON	DRB	8	250	RoHS & Green	NIPDAU	Level-2-260C-1 YEAR	-40 to 85	AQN	Samples

(1) The marketing status values are defined as follows:

ACTIVE: Product device recommended for new designs.

LIFEBUY: TI has announced that the device will be discontinued, and a lifetime-buy period is in effect.

NRND: Not recommended for new designs. Device is in production to support existing customers, but TI does not recommend using this part in a new design.

PREVIEW: Device has been announced but is not in production. Samples may or may not be available.

OBSOLETE: TI has discontinued the production of the device.

(2) **RoHS:** TI defines "RoHS" to mean semiconductor products that are compliant with the current EU RoHS requirements for all 10 RoHS substances, including the requirement that RoHS substance do not exceed 0.1% by weight in homogeneous materials. Where designed to be soldered at high temperatures, "RoHS" products are suitable for use in specified lead-free processes. TI may reference these types of products as "Pb-Free".

RoHS Exempt: TI defines "RoHS Exempt" to mean products that contain lead but are compliant with EU RoHS pursuant to a specific EU RoHS exemption.

Green: TI defines "Green" to mean the content of Chlorine (Cl) and Bromine (Br) based flame retardants meet JS709B low halogen requirements of <=1000ppm threshold. Antimony trioxide based flame retardants must also meet the <=1000ppm threshold requirement.

(3) MSL, Peak Temp. - The Moisture Sensitivity Level rating according to the JEDEC industry standard classifications, and peak solder temperature.

(4) There may be additional marking, which relates to the logo, the lot trace code information, or the environmental category on the device.

(5) Multiple Device Markings will be inside parentheses. Only one Device Marking contained in parentheses and separated by a "~" will appear on a device. If a line is indented then it is a continuation of the previous line and the two combined represent the entire Device Marking for that device.

(6) Lead finish/Ball material - Orderable Devices may have multiple material finish options. Finish options are separated by a vertical ruled line. Lead finish/Ball material values may wrap to two lines if the finish value exceeds the maximum column width.

Important Information and Disclaimer:The information provided on this page represents TI's knowledge and belief as of the date that it is provided. TI bases its knowledge and belief on information provided by third parties, and makes no representation or warranty as to the accuracy of such information. Efforts are underway to better integrate information from third parties. TI has taken and continues to take reasonable steps to provide representative and accurate information but may not have conducted destructive testing or chemical analysis on incoming materials and chemicals. TI and TI suppliers consider certain information to be proprietary, and thus CAS numbers and other limited information may not be available for release.

In no event shall TI's liability arising out of such information exceed the total purchase price of the TI part(s) at issue in this document sold by TI to Customer on an annual basis.

DRB 8

GENERIC PACKAGE VIEW

VSON - 1 mm max height

PLASTIC SMALL OUTLINE - NO LEAD

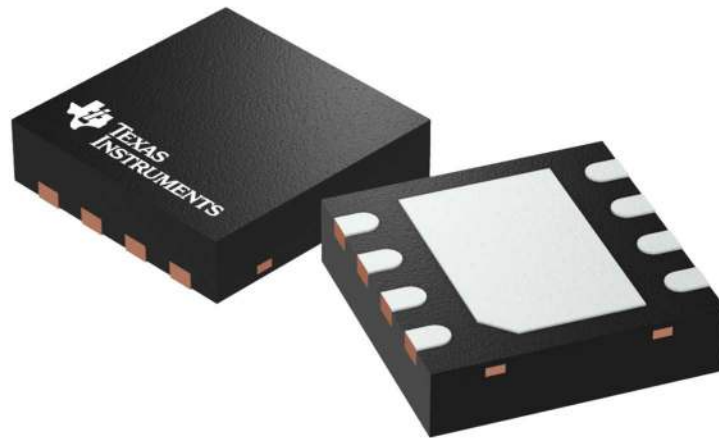

Images above are just a representation of the package family, actual package may vary.
Refer to the product data sheet for package details.

4203482/L

DRB0008A



PACKAGE OUTLINE

VSON - 1 mm max height

PLASTIC SMALL OUTLINE - NO LEAD

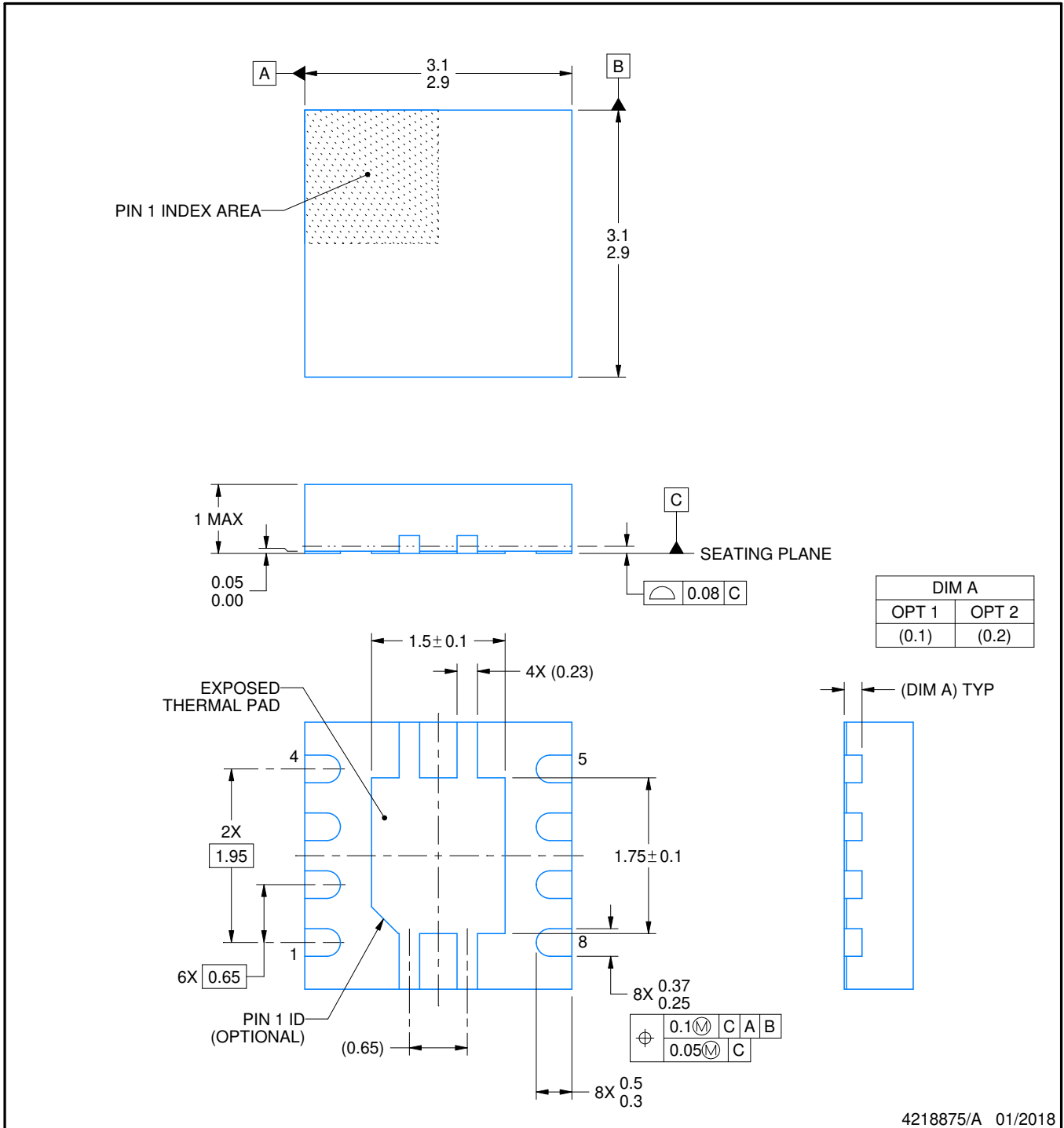

4218875/A 01/2018

NOTES:

1. All linear dimensions are in millimeters. Any dimensions in parenthesis are for reference only. Dimensioning and tolerancing per ASME Y14.5M.
2. This drawing is subject to change without notice.
3. The package thermal pad must be soldered to the printed circuit board for thermal and mechanical performance.

EXAMPLE BOARD LAYOUT

DRB0008A

VSON - 1 mm max height

PLASTIC SMALL OUTLINE - NO LEAD

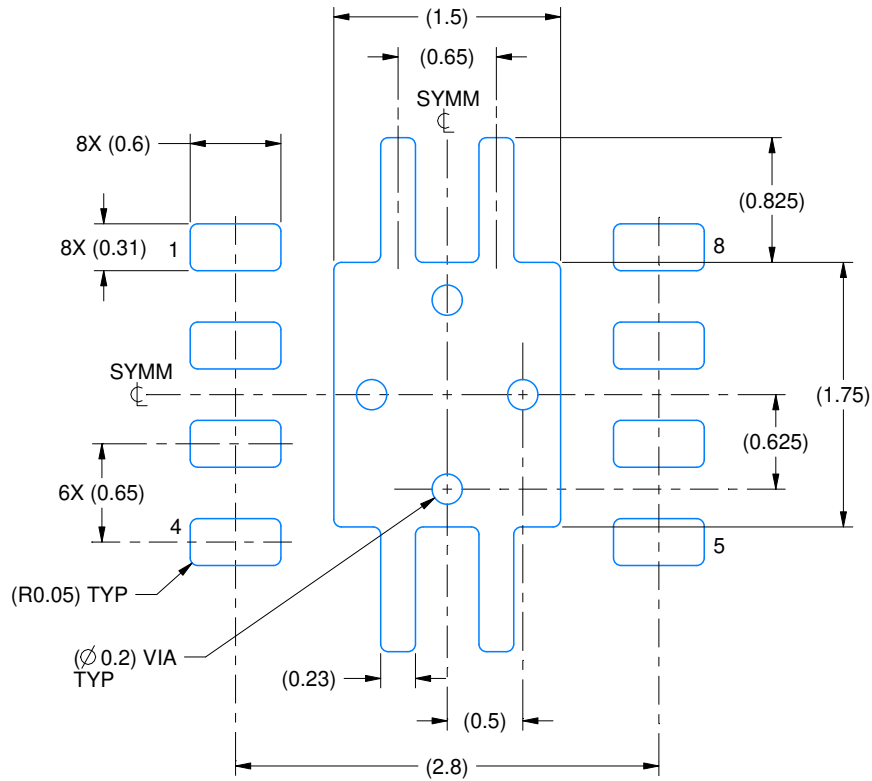

LAND PATTERN EXAMPLE
EXPOSED METAL SHOWN
SCALE:20X

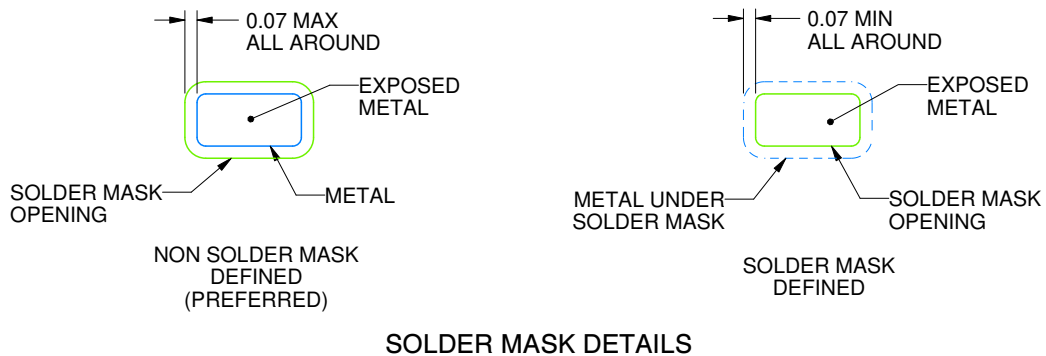

SOLDER MASK DETAILS

4218875/A 01/2018

NOTES: (continued)

4. This package is designed to be soldered to a thermal pad on the board. For more information, see Texas Instruments literature number SLUA271 (www.ti.com/lit/slue271).
5. Vias are optional depending on application, refer to device data sheet. If any vias are implemented, refer to their locations shown on this view. It is recommended that vias under paste be filled, plugged or tented.

EXAMPLE STENCIL DESIGN

DRB0008A

VSON - 1 mm max height

PLASTIC SMALL OUTLINE - NO LEAD

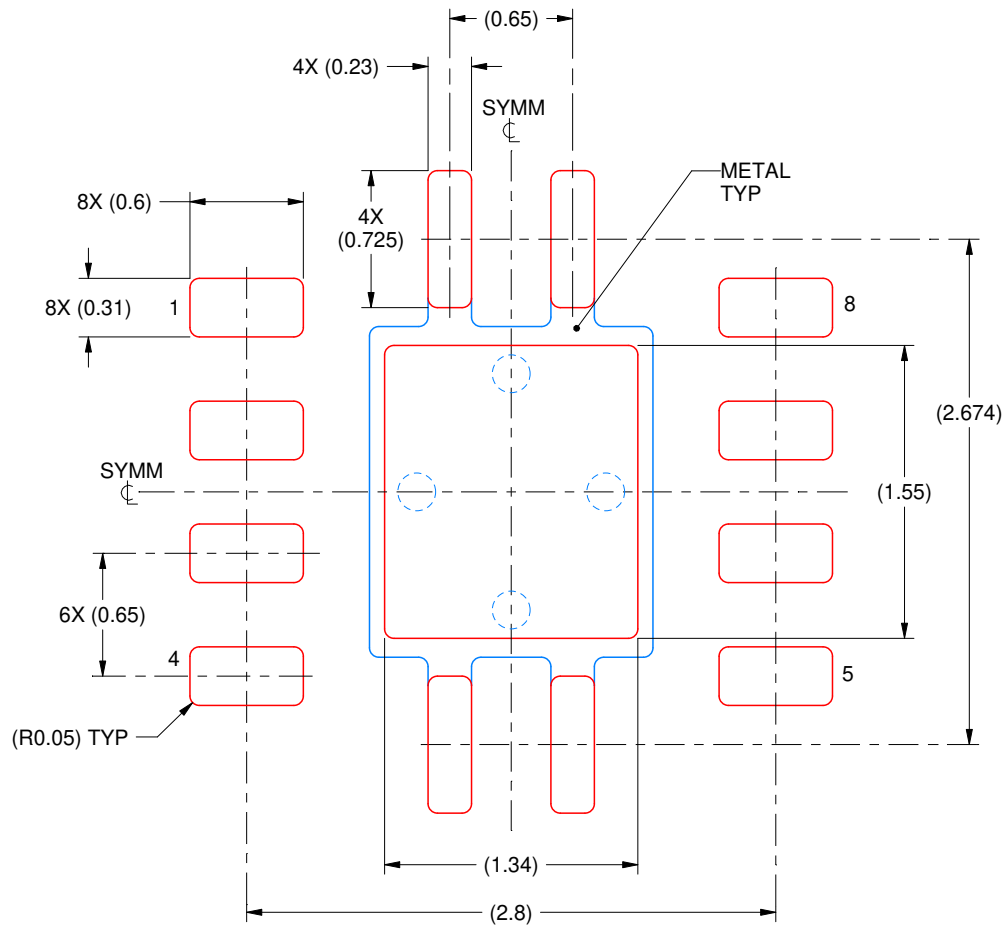

SOLDER PASTE EXAMPLE
BASED ON 0.125 mm THICK STENCIL

EXPOSED PAD
84% PRINTED SOLDER COVERAGE BY AREA
SCALE:25X

4218875/A 01/2018

NOTES: (continued)

6. Laser cutting apertures with trapezoidal walls and rounded corners may offer better paste release. IPC-7525 may have alternate design recommendations.

IMPORTANT NOTICE AND DISCLAIMER

TI PROVIDES TECHNICAL AND RELIABILITY DATA (INCLUDING DATA SHEETS), DESIGN RESOURCES (INCLUDING REFERENCE DESIGNS), APPLICATION OR OTHER DESIGN ADVICE, WEB TOOLS, SAFETY INFORMATION, AND OTHER RESOURCES "AS IS" AND WITH ALL FAULTS, AND DISCLAIMS ALL WARRANTIES, EXPRESS AND IMPLIED, INCLUDING WITHOUT LIMITATION ANY IMPLIED WARRANTIES OF MERCHANTABILITY, FITNESS FOR A PARTICULAR PURPOSE OR NON-INFRINGEMENT OF THIRD PARTY INTELLECTUAL PROPERTY RIGHTS.

These resources are intended for skilled developers designing with TI products. You are solely responsible for (1) selecting the appropriate TI products for your application, (2) designing, validating and testing your application, and (3) ensuring your application meets applicable standards, and any other safety, security, regulatory or other requirements.

These resources are subject to change without notice. TI grants you permission to use these resources only for development of an application that uses the TI products described in the resource. Other reproduction and display of these resources is prohibited. No license is granted to any other TI intellectual property right or to any third party intellectual property right. TI disclaims responsibility for, and you will fully indemnify TI and its representatives against, any claims, damages, costs, losses, and liabilities arising out of your use of these resources.

TI's products are provided subject to [TI's Terms of Sale](#) or other applicable terms available either on [ti.com](https://www.ti.com) or provided in conjunction with such TI products. TI's provision of these resources does not expand or otherwise alter TI's applicable warranties or warranty disclaimers for TI products.

TI objects to and rejects any additional or different terms you may have proposed.

Mailing Address: Texas Instruments, Post Office Box 655303, Dallas, Texas 75265
Copyright © 2023, Texas Instruments Incorporated