

Approved	Checked	Designed	DEVELOPMENT SPECIFICATION					
		<i>K. Shibasaki</i>	Tentative P/N:LNJ210C62RA					
T Y P E			Red Emitting Diode					
APPLICATION			Indicators					
MATERIAL			InGaAlP					
OUTLINE			Attached					
ABSOLUTE MAXIMUM RATINGS			P	*1 I_{FP}	I_{FDC}	V_R	Topr	Tstg
			55	60	20	4	-25~+85	-30~+100
			mW	mA	mA	V	°C	°C
CONDITION			$T_a = 25 \pm 3$ °C					
Test Specification								
Item	Symbol	Condition	Typ.	Limit		Unit		
				Min	Max			
Forward Voltage	V_F	$I_F = 10$ mA	1.92		2.5	V		
Reverse Leakage Current	I_R	$V_R = 4$ V		12	100	μ A		
Luminous Intensity *2	I_O	$I_F = 10$ mA DC	23	12		mcd		
Peak Emission Wavelength	λ_P	$I_F = 10$ mA DC	645			nm		
Spectral Line Half Width	$\Delta\lambda$	$I_F = 10$ mA DC	15			nm		
<p>*1 · The Condition of I_{FP} is duty 10 %, Pulse width 1 ms · Please contact the Panasonic local office if you design at low current (below 1 mA DC) or pulse current operation and have any questions.</p> <p>*2 Measurement Tolerance is $\pm 20\%$.</p>								
NOTE								
★1. Terminal:Plated with gold on copper base.								
★2. Beware of destruction by static electricity in handling the LED.								
★3. Package : Clear type.								
★4. Soldering conditions. Refer to Handling note.								
★5. Care should be taken that soldering is done within 3-days after opening the dry package and reel.								
★6. Circuit to operate LED.								
				(A) Recommended circuit.				
				(B) The difference of brightness between the LED could be found due to the V_F characteristics of each LED.				
(A)								
(B)								
Oct. 20. 2001								

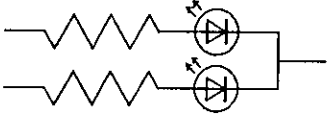
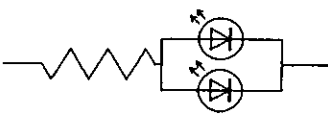
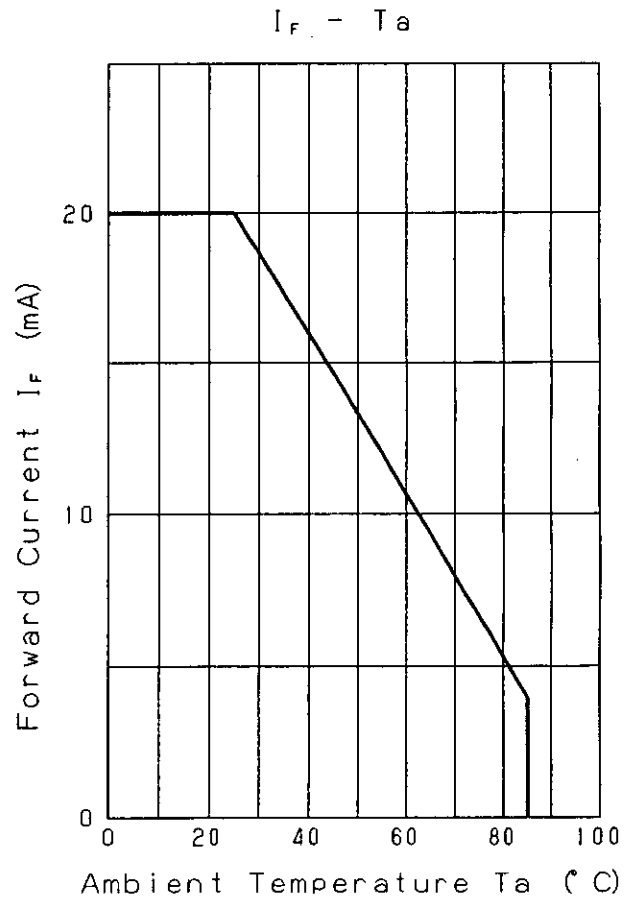
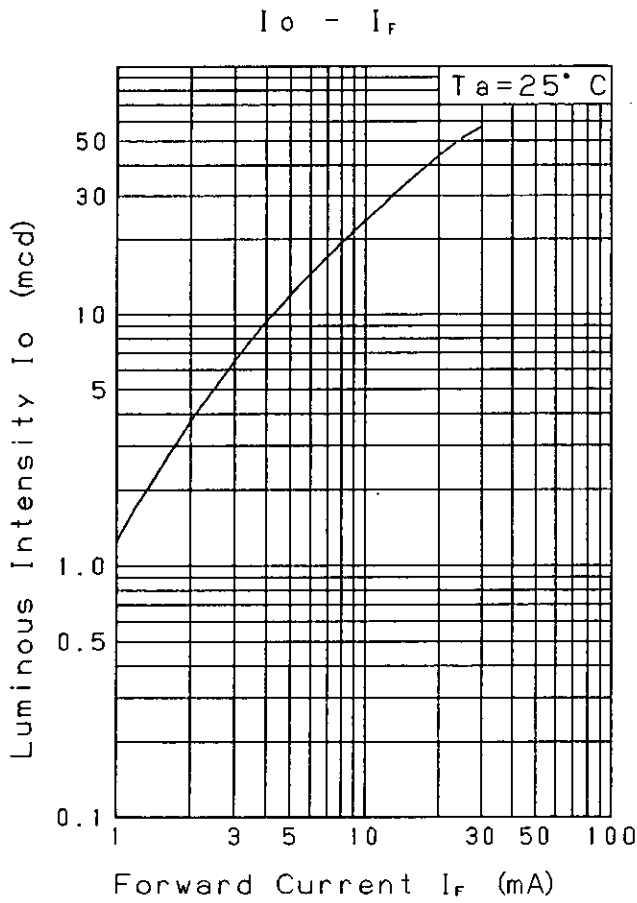
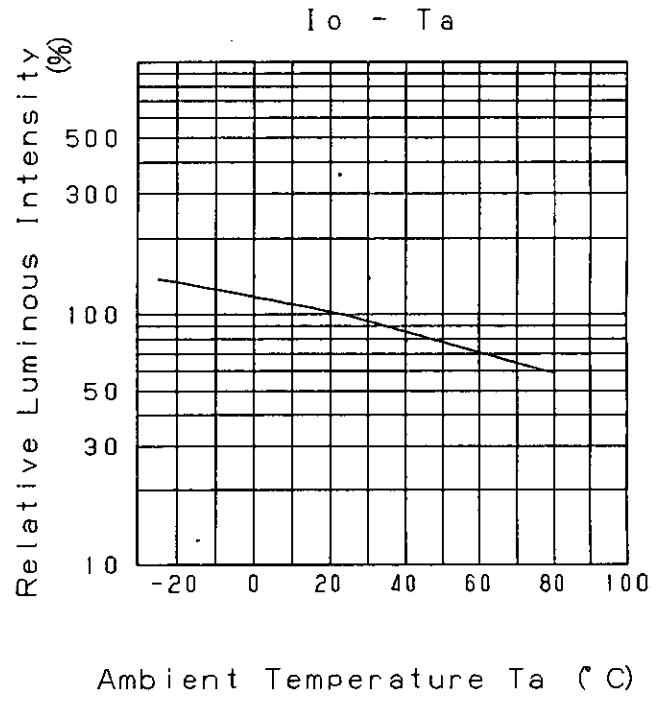
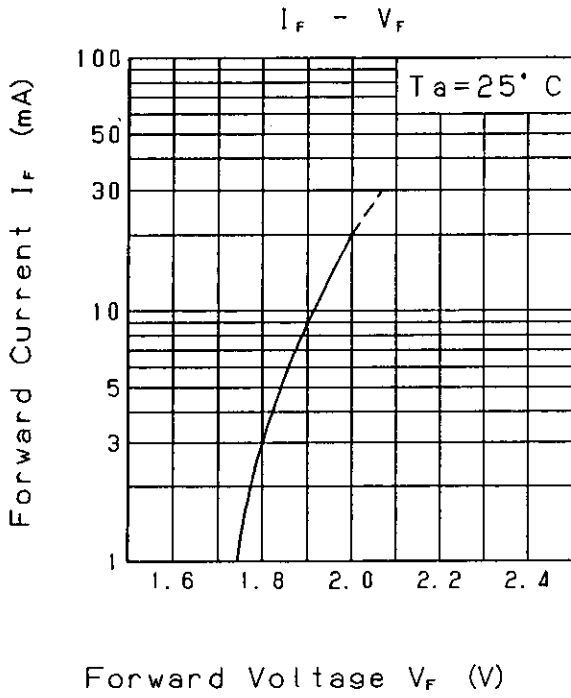

Oct. 20. 2001			
---------------	--	--	--

Approved	Checked	Designed <i>K. A. S. S.</i>	DEVELOPMENT SPECIFICATION		
			Tentative P/N : LNJ210C62RA		

Relative Luminous Intensity
Wavelength Characteristics

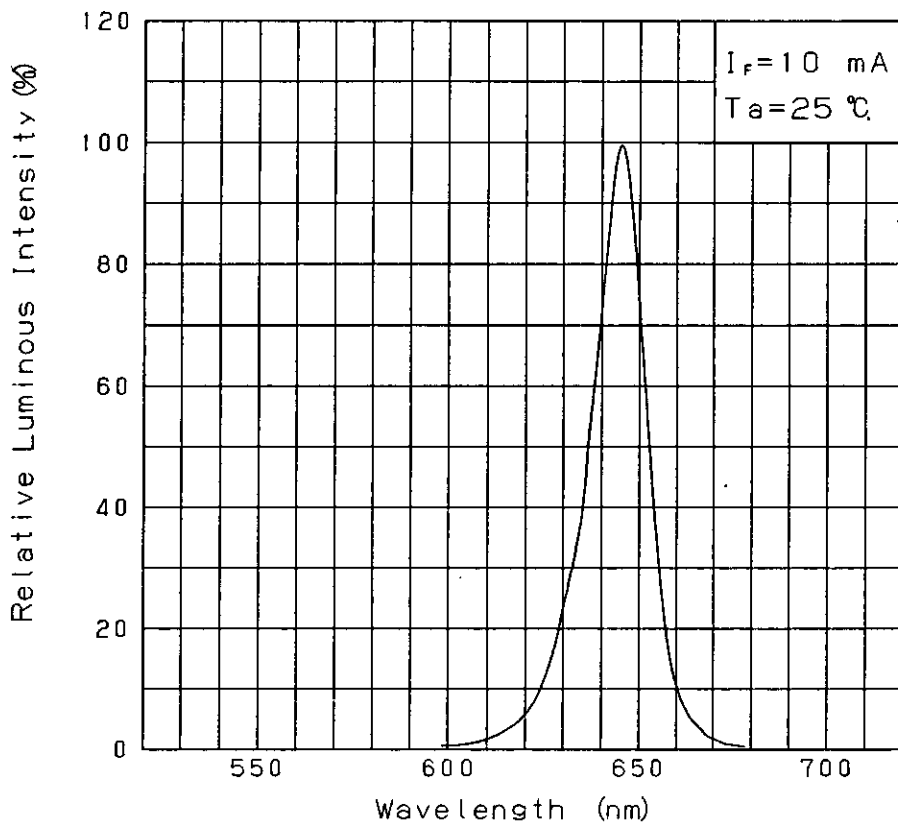

Directive Characteristics

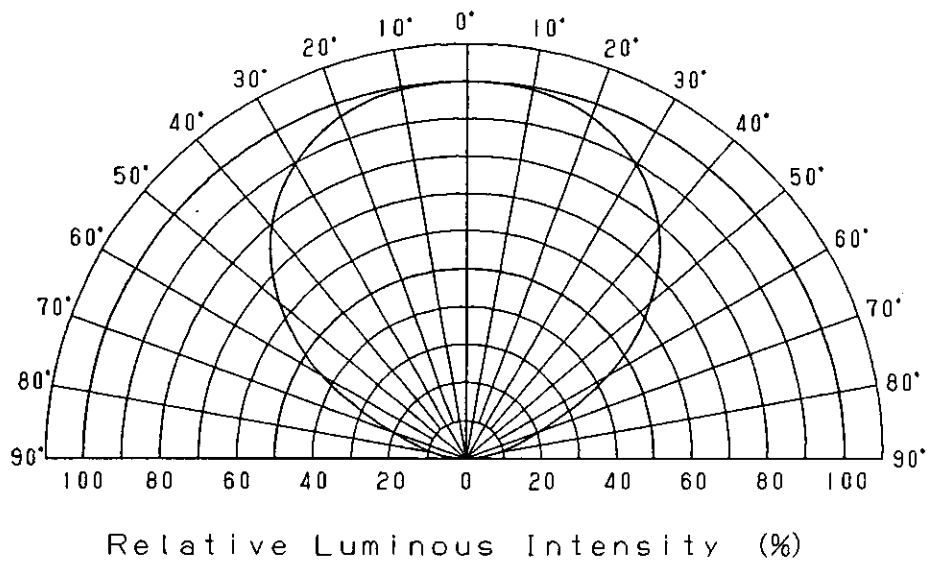

Oct. 20. 2001			

Approved	Checked	Designed <i>K. Adachi</i>
----------	---------	------------------------------

DEVELOPMENT SPECIFICATION
(OUTLINE) Tentative
P/N: LNJ210C62RA

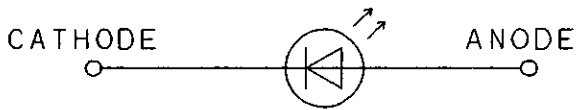
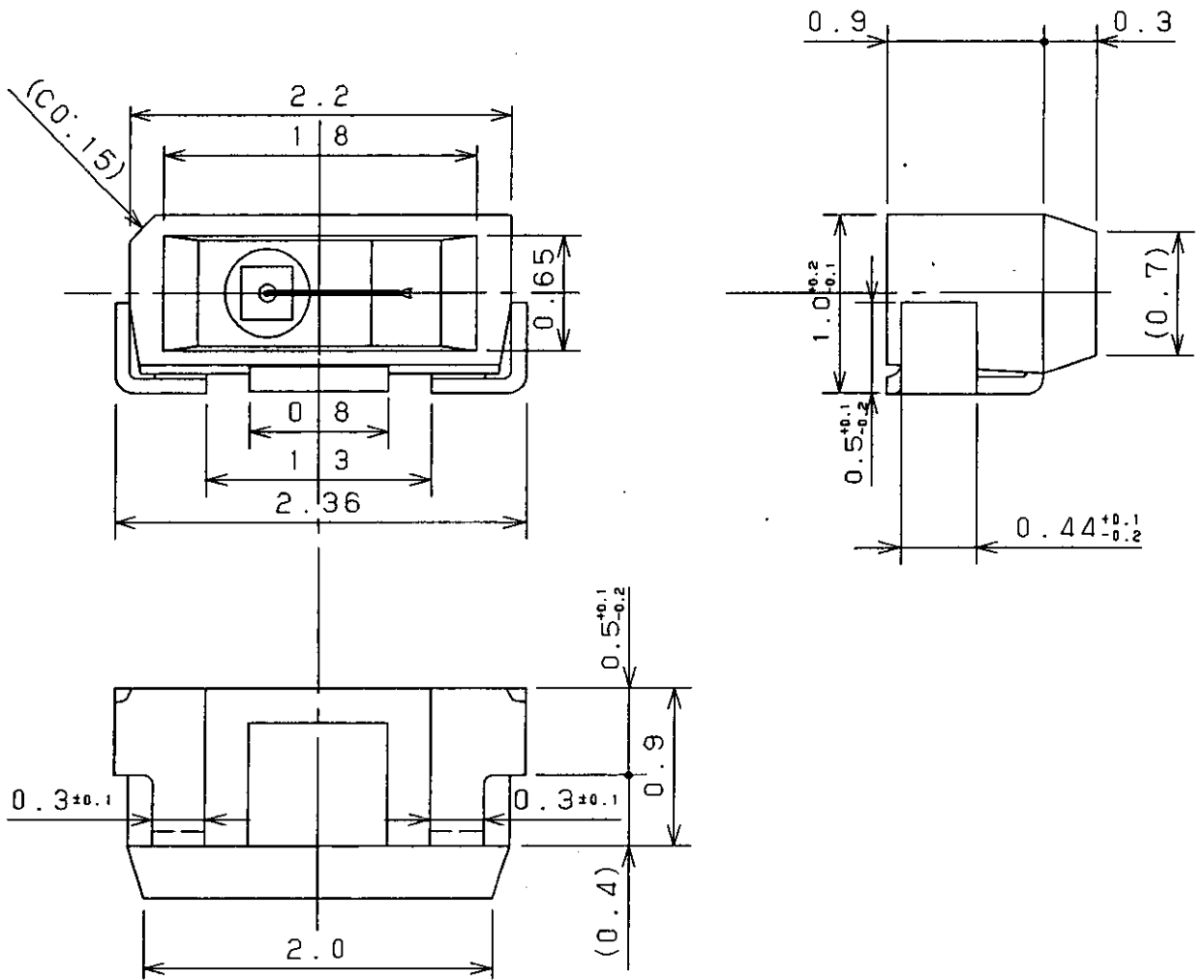

(NOTE)
1. Unit: mm
2. Tolerance unless specified is ± 0.15 .

Oct. 20. 2001