

LOC		DIST		REVISIONS			
P	LTN	DESCRIPTION	DATE	DMN	APVD		
V		REV PER ECO 13-009837	6-13-13	CT	DM		

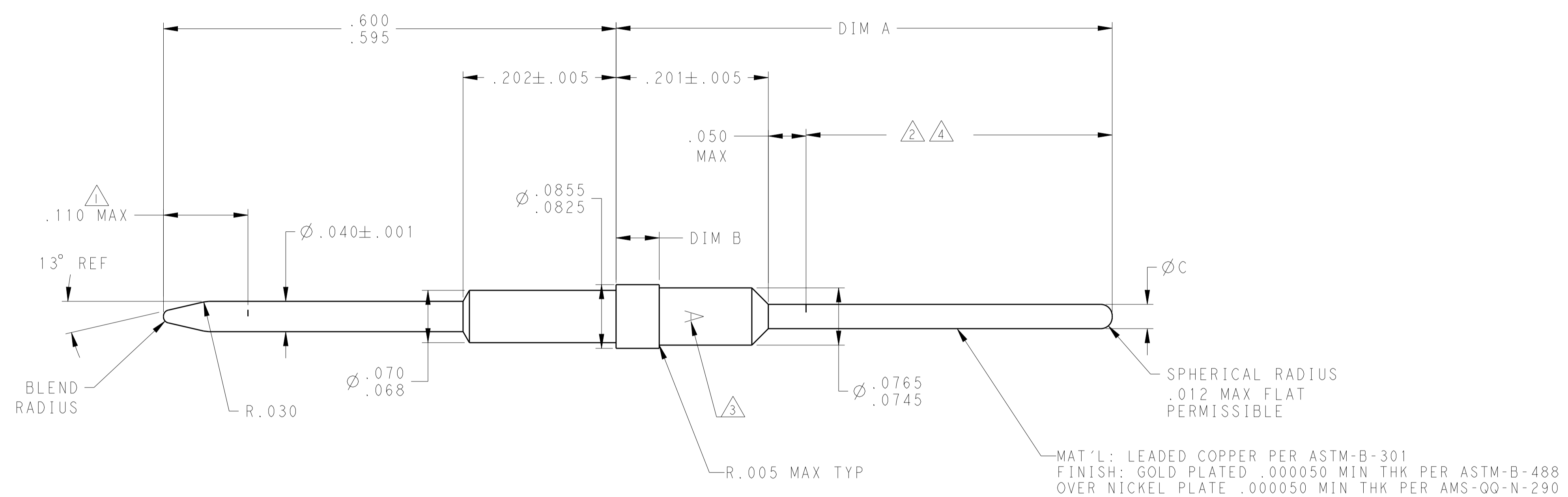

- △ ELECTRICAL ENGAGEMENT POINT.
- ② THIS AREA SOLDER DIPPED.
- ③ MANUFACTURERS LOGO; LACATION & ORIENTATION OPTIONAL.
- ④ SOLDER IS RoHS-COMPLIANT Sn.

△	.038 MAX	.055-.059	.697	4-448138-2
	.030-.034	.055-.059	.697±.005	4-448138-1
② ④	.038 MAX	.055-.059	.780	3-448138-8
△	.038 MAX	.055-.059	.780	3-448138-7
--	.030-.034	.055-.059	.780±.005	3-448138-6
△	.038 MAX	.055-.059	.620±.005	3-448138-3
② ④	.038 MAX	.055-.059	.620±.005	3-448138-2
△	.038 MAX	.055-.059	.905±.005	3-448138-1
--	.030-.034	.055-.059	.905±.005	3-448138-0
△	.038 MAX	.055-.059	.661	2-448138-7
--	.030-.034	.055-.059	.655±.005	2-448138-6
--	.030-.034	.055-.059	.620±.005	2-448138-3
--	.030-.034	.055-.059	.404±.005	2-448138-0
△	.038 MAX	.055-.059	.510±.005	1-448138-7
△	.038 MAX	.055-.059	.546±.005	1-448138-6
--	.030-.034	.055-.059	.546±.005	1-448138-5
--	.030-.034	.055-.059	.510±.005	1-448138-2
--	.030-.034	.0655-.0695	.546	448138-9
--	.030-.034	.0655-.0695	.661	448138-6
--	.030-.034	.0655-.0695	.546	448138-3
REMARKS	DIM C	DIM B	DIM A	PART NO.

THIS DRAWING IS A CONTROLLED DOCUMENT. DWN: C.C. THOMAS 27OCT2009
 CHK: K. THACKSTON 27OCT2009
 APVD: K. THACKSTON 27OCT2009

STE TE Connectivity
 POSTED PIN CONTACT, SIZE 20, ARINC 600

DIMENSIONS: INCHES	TOLERANCES UNLESS OTHERWISE SPECIFIED:	0 PLC ±.010	1 PLC ±.010	2 PLC ±.010	3 PLC ±.010	4 PLC ±.010	ANGLES ±.010	FINISH SEE CALLOUTS	WEIGHT	SIZE: A1	CAGE CODE: 00779	DRAWING NO: 448138	RESTRICTED TO		
MATERIAL: SEE TABLE										SCALE: 15:1		SHEET 1 OF 1		REV V	

CUSTOMER DRAWING