



SPECIFICATION
FOR ELECTRO-MAGNET TRANSDUCER

TOTAL PAGE 9 www.bestargroups.com RoHS

Customer		Model Name	SMT5050-03H02 LF
Customer P/N		Product No.	050718
Date	19 Aug. 2015	Issue No.	BS/TET01.544E
Page	01 of 09	Issue Date	2015/08/19

Approval:

- 1.Characteristics
- 2.Dimension
- 3.Reliability Test
- 4.Frequency Characteristics Chart
- 5.Surface Mounting Condition
- 6.Reel Packing
- 7.Notice
- 8.History change record

Drawn by	Checked by	Approved by	Customer approved
常 琦	陶红仲	张秀琴	

BESTAR HOLDING CO.,LTD

No.199 HuangHe West Road.New district,ChangZhou,JiangSu Province,P.R.China

Tel: +86 519 88222567 **Fax:** +86 519 88222551

E-mail: wu@be-star.com **http://**www.bestargroups.com

SMT5050-03H02 LF

1. Characteristics

1.1 Features

1. SMD;thinner , smaller size
2. High S.P.L.; and clear sound
3. Reflowable;RoHS complant
4. Tape & Reel supply
5. Minimum quantity (one reel): 2000 pcs.

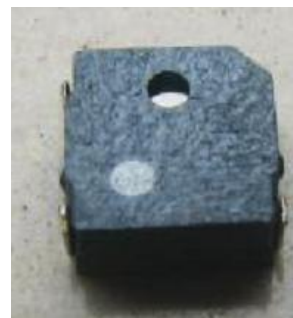

1.2 Electrical and Mechanical Characteristics

No.	Item	Specifications
1	Rated Voltage	3Vo - p
2	Operating Voltage range	2-4Vo - p
3	Rated Frequency	4000Hz
4	Rated Current	max.110mA
5	Coil Resistance	12±3 Ω
6	a) Sound Pressure Level at 10cm	min.75dB
7	Operating Temperature	-20...+70 °C
8	Storage Temp.	-30...+80 °C
9	Weight	0.6 g
a)Value applying rated voltage (4000Hz,1/2 duty,square wave)		

1.3 Test method:

1.31.Recommended Circuit

the following are examples of externally driven circuits.

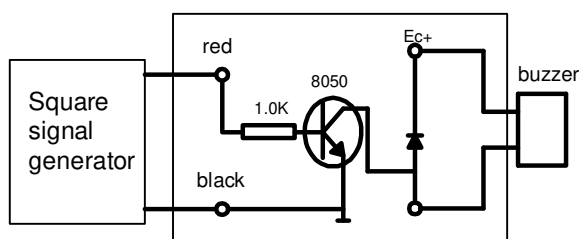

1.32.Standard test Fixture

No reaction in space with in 400mm in all direction

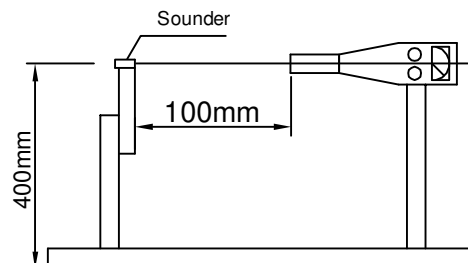

E	2015/08/19	常琦	add the ESD bag	Date:	2015/08/19	SMT5050-03H02 LF	
D	14/03/07	徐波		Drawn by:	常琦		
C	13/12/13	徐波		Checked by:	陶红仲		
REV.	Date	Drawn	Note	Approved by:	张秀琴	Transducer	
BESTAR HOLDING CO.,LTD						BS/TET01.544E	Page:2 of 9
www.bestargroups.com wu@be-star.com							

SMT5050-03H02 LF

2.Dimension

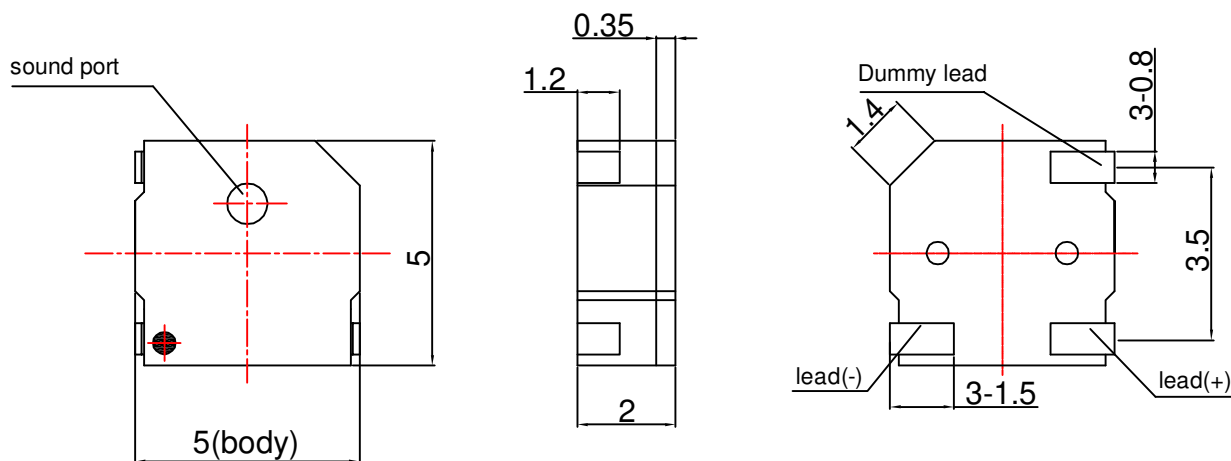

Unit:mm
tolerance:±0.3

Recommendable land pattern

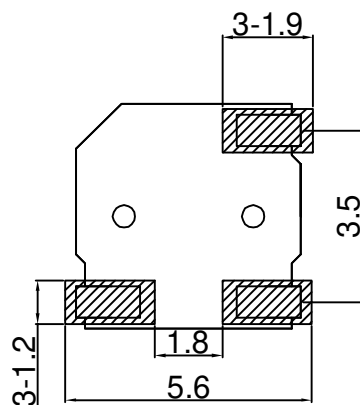

This print and information there in are proprietary to BeStar Holding Co., Ltd. and shall not be used in whole or in part without its written content

E	2015/08/19	常琦	add the ESD bag	Date:	2015/08/19	SMT5050-03H02 LF	
D	14/03/07	徐波		Drawn by:	常琦		
C	13/12/13	徐波		Checked by:	陶红仲	Transducer	
REV.	Date	Drawn	Note	Approved by:	张秀琴		
BESTAR HOLDING CO.,LTD						BS/TET01.544E	Page:3 of 9
www.bestargroups.com wu@be-star.com							

SMT5050-03H02 LF

3. Reliability Test

3.1 high temperature test

Temperature +80°C
Duration 240hrs

3.2 low temperature test

Temperature -30°C
Duration 240hrs

3.3 life test in normal temperature

Temperature 25±10°C
Power supply 3.0Vo-p square wave 1/2 duty 4kHz
Duration 240hrs

3.4 Thermal shock

Cycles 50

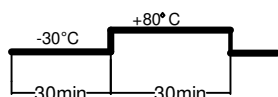

3.5 Humidity cycle test

Cycles 5

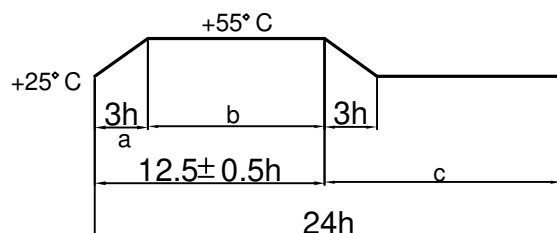

a,c :95-100%RH

b : 90-96%RH

Cycles 6

3.6 High Temp. life

Temp. +70°C
Power supply 3.0Vo-p Square wave 1/2 duty 4kHz
Duration 240hrs

3.7 Low Temp. life

Temp. -30°C
Power supply 3.0Vo-p Square wave 1/2 duty 4kHz
Duration 240hrs

This print and information there in are proprietary to BeStar Holding Co., Ltd. and shall not be used in whole or in part without its written content

E	2015/08/19	常琦	add the ESD bag	Date:	2015/08/19	SMT5050-03H02 LF	
D	14/03/07	徐波		Drawn by:	常琦		
C	13/12/13	徐波		Checked by:	陶红仲	Transducer	
REV.	Date	Drawn	Note	Approved by:	张秀琴		
BESTAR HOLDING CO.,LTD www.bestargroups.com wu@be-star.com						BS/TET01.544E	Page:4 of 9

SMT5050-03H02 LF

- 3.8 Vibration
 - Frequency 10 ~ 200 ~ 10Hz
 - Amplitude 1.5mm
 - Direction X,Y&Z
 - Duration 2hrs each, total 6hrs
- 3.9 Fixed drop
 - Drop height 152mm
 - Duration every 6 surface 5 times(total 30 times)
- 3.10 Free drop test
 - Drop height 100cm
 - Duration 6 every surface 1 time
 - (Exclude bending of pin)
- 3.11 Solderability
 - Solder temp. 255±5°C
 - Soaking time 2±0.5sec
- 3.12 Direct current
 - Power supply 4.0VDC(+/GND)
 - Duration 1hr

4. Frequency Characteristics Chart

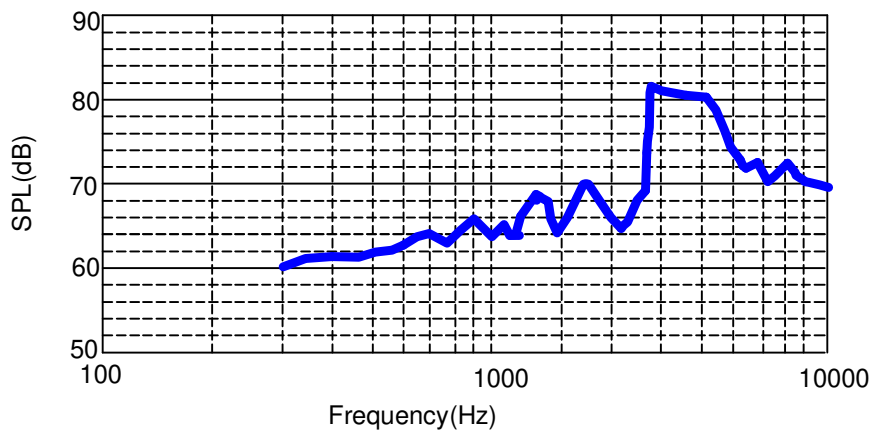

This print and information there in are proprietary to BeStar Holding Co., Ltd. and shall not be used in whole or in part without its written content

E	2015/08/19	常琦	add the ESD bag	Date:	2015/08/19	SMT5050-03H02 LF	
D	14/03/07	徐波		Drawn by:	常琦		
C	13/12/13	徐波		Checked by:	陶红仲	Transducer	
REV.	Date	Drawn	Note	Approved by:	张秀琴		
BESTAR HOLDING CO.,LTD						BS/TET01.544E	Page:5 of 9
www.bestargroups.com wu@be-star.com							

SMT5050-03H02 LF

5. Surface Mounting Condition

In automated mounting of The SMD Sound Transducers on printed circuit boards, any bending, expanding and pulling forces or shocks against the SMD Sound Transducers shall be kept minimum to prevent them from electrical failures and mechanical damages of the devices.

Soldering (Reflow)

- (1) Solderings of The SMD Sound Transducers shall conform to the soldering conditions in the individual specifications.
- (2) The SMD Sound Transducers are designed for "Reflow Solderings"
- (3) In the reflow solderings, too high soldering temperatures and too large temperature gradient such as rapid heating or cooling may cause electrical failures and mechanical damages of the devices.

Following soldering conditions are recommended; Refer to Fig.1

Temperature profile for a lead-free reflow process

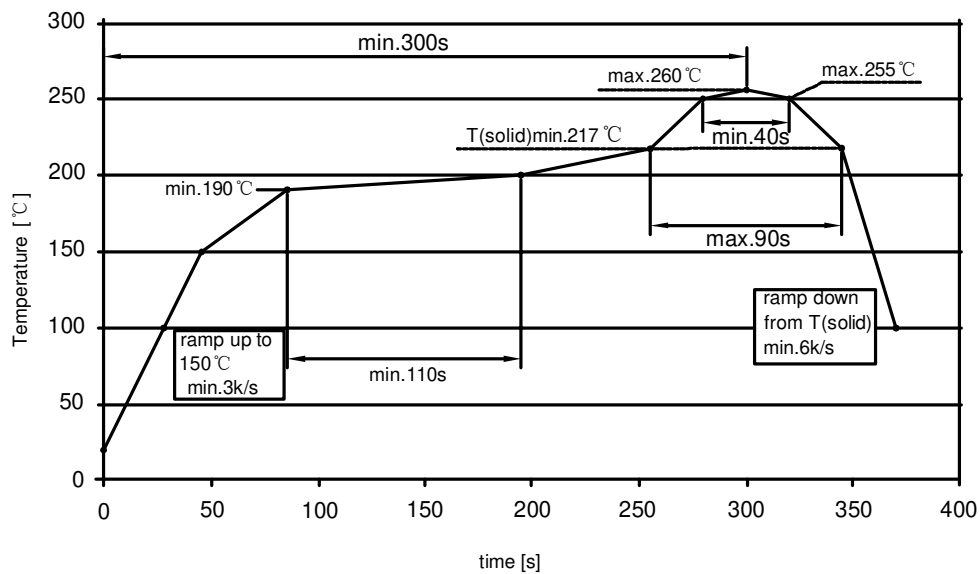

Fig. 1 Recommended soldering Temperature-Time profile (Reflow soldering)

E	2015/08/19	常琦	add the ESD bag	Date:	2015/08/19	Transducer	
D	14/03/07	徐波		Drawn by:	常琦		
C	13/12/13	徐波		Checked by:	陶红仲		
REV.	Date	Drawn	Note	Approved by:	张秀琴		
BESTAR HOLDING CO.,LTD						BS/TET01.544E	Page:6 of 9
www.bestargroups.com wu@be-star.com							

This print and information there in are proprietary to BeStar Holding Co., Ltd. and shall not be used in whole or in part without its written content

SMT5050-03H02 LF

6.Reel Packing

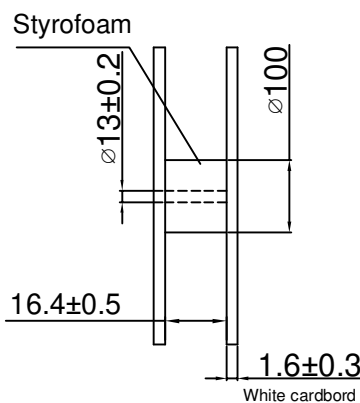
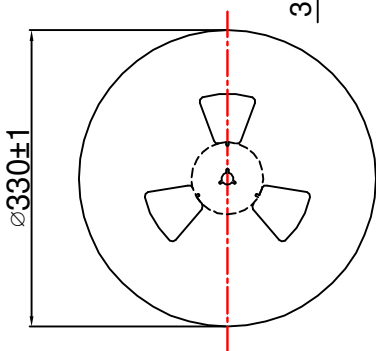
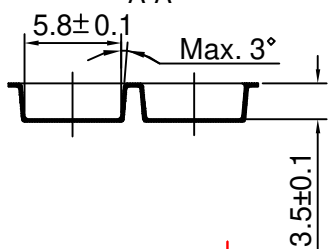
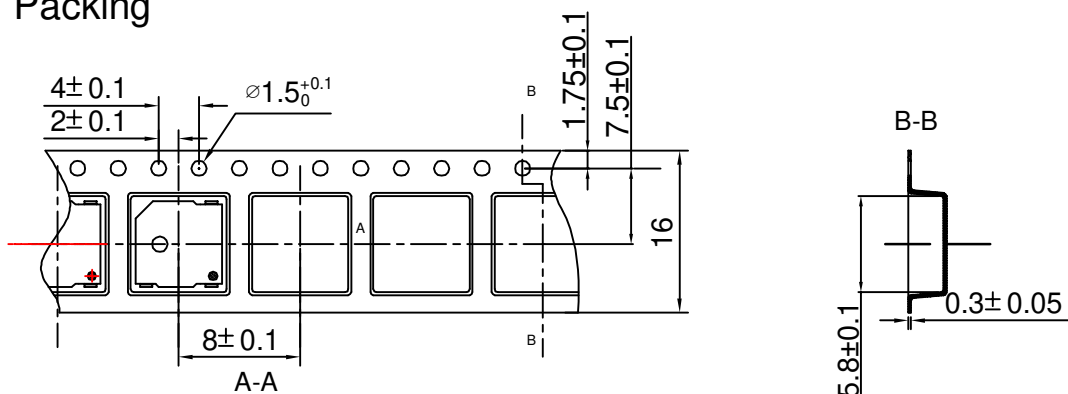

1) Leader section

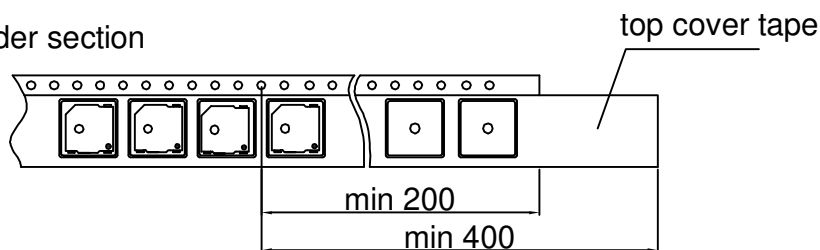

2) Trailer section

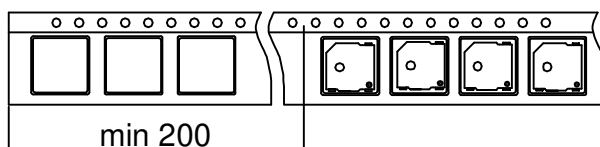

This print and information there in are proprietary to BeStar Holding Co., Ltd. and shall not be used in whole or in part without its written consent

E	2015/08/19	常琦	add the ESD bag	Date:	2015/08/19	SMT5050-03H02 LF	
D	14/03/07	徐波		Drawn by:	常琦		
C	13/12/13	徐波		Checked by:	陶红仲	Transducer	
REV.	Date	Drawn	Note	Approved by:	张秀琴		
BESTAR HOLDING CO.,LTD						BS/TET01.544E	Page:7 of 9
www.bestargroups.com wu@be-star.com							

SMT5050-03H02 LF

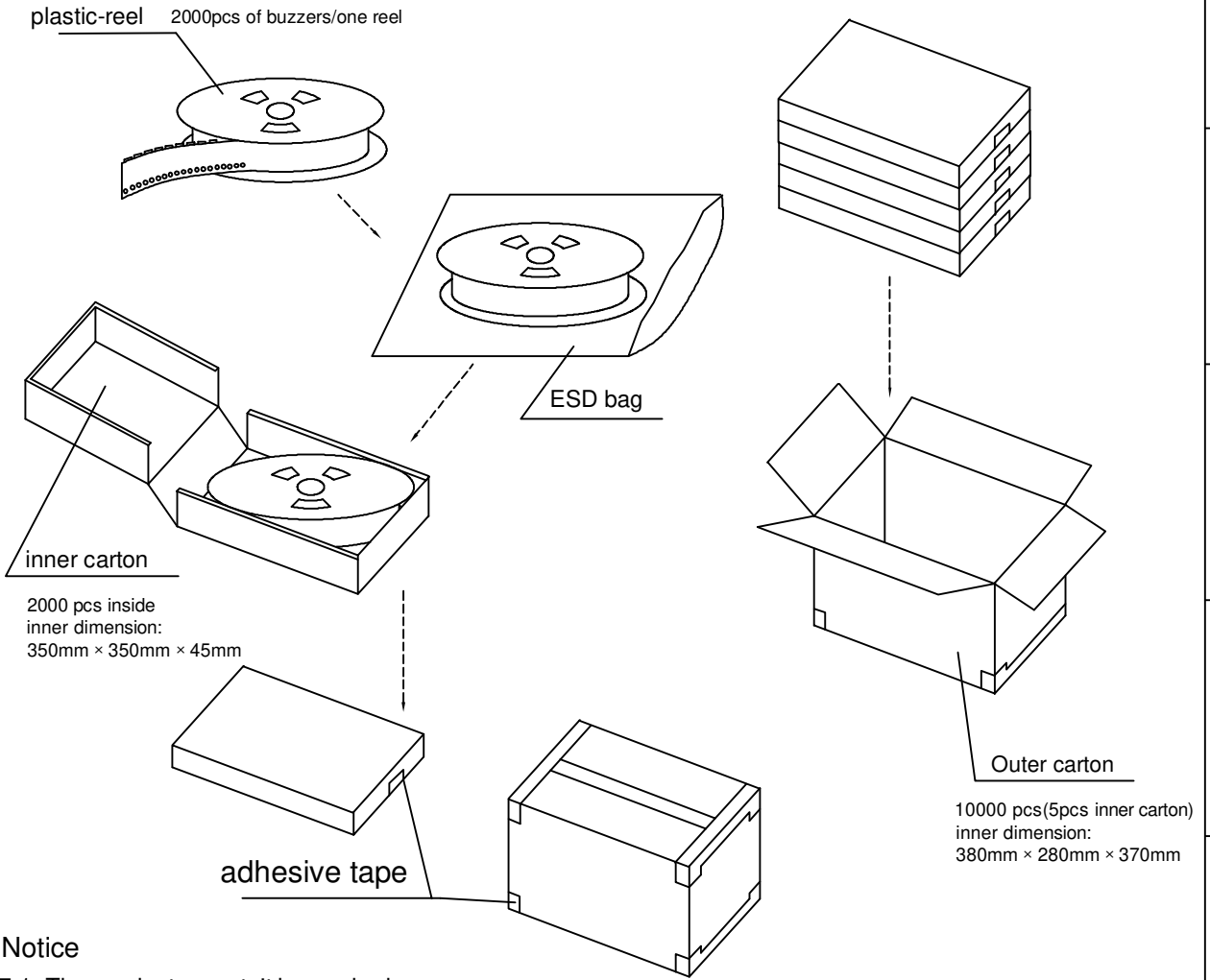

7. Notice

7.1 The products mustn't be washed

7.2 Storage Condition

The products should be stored in the room, where the temperature/humidity is stable. And avoid such places where there are large temperature changes. Please store the products at the following conditions:

Temperature: -10 to + 40 °C Humidity: 15 to 85% R.H.

7.3 Expire Date on Storage

Expire date (Shelf life) of the products is six months after delivered under the conditions of a sealed and an unopened package. Please use the products within six months after delivered.

If you store the products for a long time (more than six months), use carefully because the products may be degraded in the solderability and/or rusty. Please confirm solderability and characteristics for the products regularly.

7.4 Notice on Product Storage

(1) Please do not store the products in a chemical atmosphere (Acids, Alkali, Bases, Organic gas, Sulfides and so on), because the characteristics may be reduced at quality, and/or be degraded in the solderability due to the storage in a chemical atmosphere.

(2) Please use the products immediately after the package is opened, because the characteristics may be reduced at quality, and/or be degraded in the solderability due to storage under the poor condition.

This print and information there in are proprietary to BeStar Holding Co., Ltd. and shall not be used in whole or in part without its written content

E	2015/08/19	常琦	add the ESD bag	Date:	2015/08/19	SMT5050-03H02 LF	
D	14/03/07	徐波		Drawn by:	常琦		
C	13/12/13	徐波		Checked by:	陶红仲	Transducer	
REV.	Date	Drawn	Note	Approved by:	张秀琴		
BESTAR HOLDING CO.,LTD						BS/TET01.544E	Page:8 of 9
www.bestargroups.com wu@be-star.com							

SMT5050-03H02 LF

8. History change record

version No.	Change Items		Date	Drawn	Approved
	Before	After			
A			08/07/09	魏奉玲	张秀琴
B		add recommendable land pattern	10/08/11	徐波	王平
C		Change the external dimensions	13/12/13	徐波	徐金国
D		change the dimension of the reel packing	14.03.07	徐波	徐金国
E		add the ESD bag	2015.08.19	常琦	张秀琴

This print and information there in are proprietary to BeStar Holding Co., Ltd. and shall not be used in whole or in part without its written content

E	2015/08/19	常琦	add the ESD bag	Date:	2015/08/19	SMT5050-03H02 LF
D	14/03/07	徐波		Drawn by:	常琦	
C	13/12/13	徐波		Checked by:	陶红仲	
REV.	Date	Drawn	Note	Approved by:	张秀琴	Transducer
BESTAR HOLDING CO.,LTD						BS/TET01.544E
www.bestargroups.com wu@be-star.com						Page:9 of 9