

NOTES:

1. MATERIAL:
 - 1.1 HOUSING: LCP, UL94V-0, COLOR: BLACK.
 - 1.2 CONTACT: PHOSPHOR BRONZE.
2. FINISH:
 - 2.1 CONTACT: 50u" MIN NICKEL UNDERPLATED ALL OVER. GOLD FLASH PLATING ON SOLDER TAIL. GOLD PLATING (THICKNESS SEE TABLE) ON CONTACT AREA.
3. DATE CODE : FYYWDLX
 - YY: YEAR (09: 2009)
 - WW: WEEK (25: THE 25TH WEEK)
 - D: DAY (1~7: SUNDAY~SATURDAY)
 - L: LINE NUMBER OF ASSEMBLY (A: LINE A)
 - X: D OR N (D: DAY; N: NIGHT)
4. PART NUMBER DESCRIPTION:

10153311-0XXX LF

OPTION	DIM"A"	DIM"B"	SATUS
0	73.4	36.7	TOOLED
1	68.8	34.4	TOOLED

LF: LEAD FREE

T: SOFT TRAY
H: HARD TRAY

PLATING CODE:
1: GF
4: Au15u"
5: Au30u"

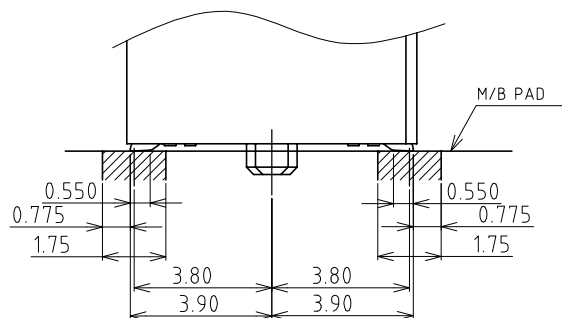
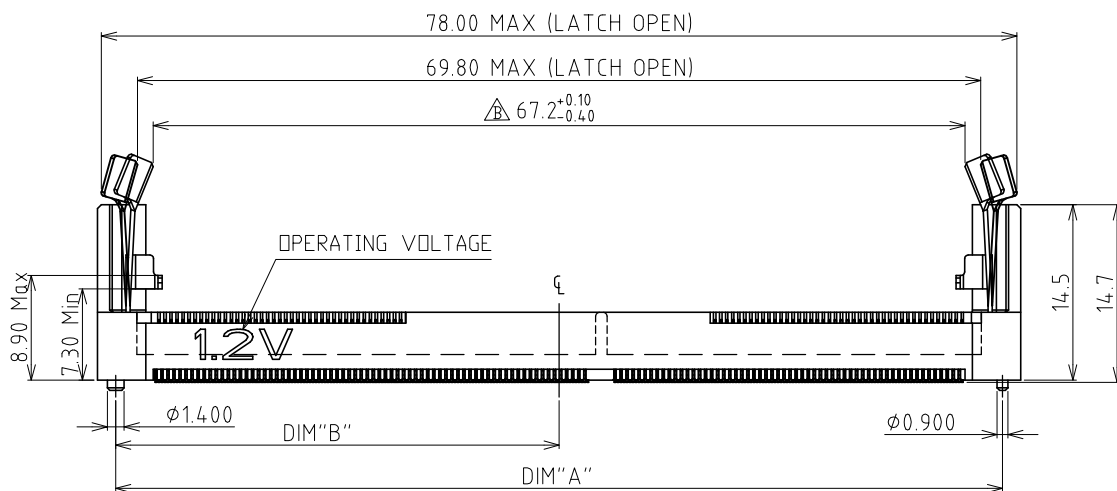
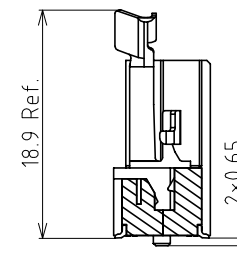

SOLDERING DIM
DETAIL 3:1

SOLDERING DIM

mat'l. code		surface		tolerance		projection		product family	
-		-		ASME_Y14.5				DDR4	
ltr		ecn no		dr		date		title	
								DDR4_SODIMM_VERTICAL	
								STD_260PIN	
								dwg no	
								sheet 1 of 5	
								size	
								A4	
								type	
								CUSTOMER Drawing	
sheet index		revision sheet		B					

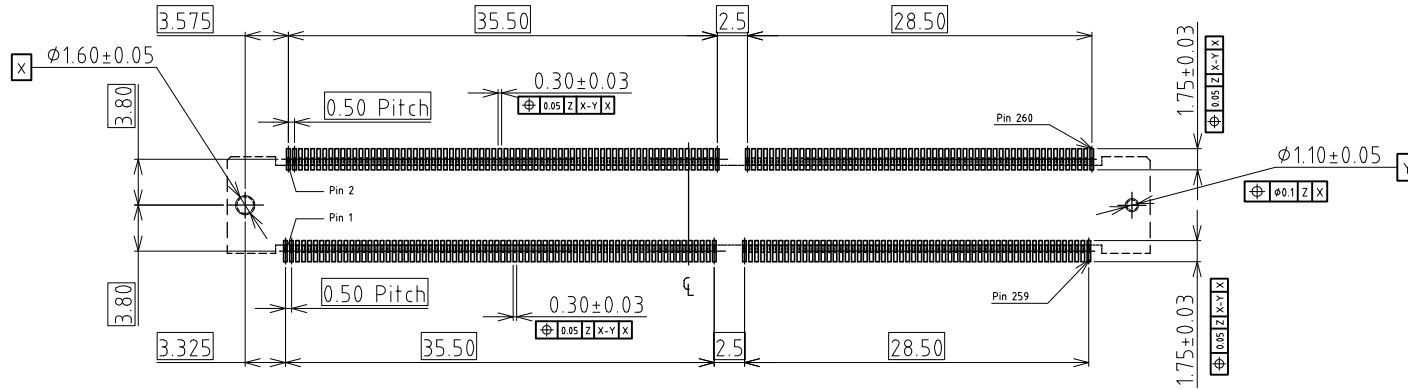

RECOMMENDED P.C.B LAYOUT (±0.05)-(DIMA=73.4)

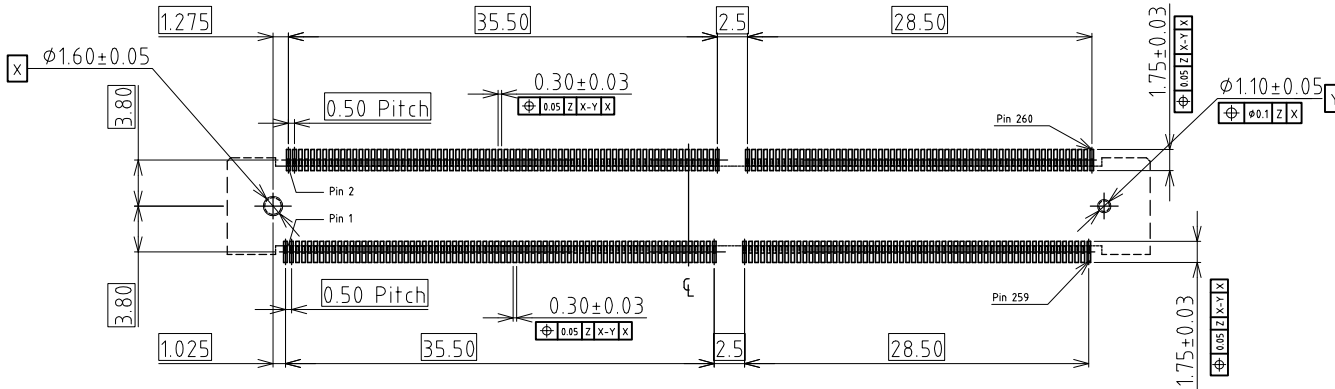

RECOMMENDED P.C.B LAYOUT (±0.05)-(DIMA=68.8)

1.A PCB SIDE BE DETAM "Z"

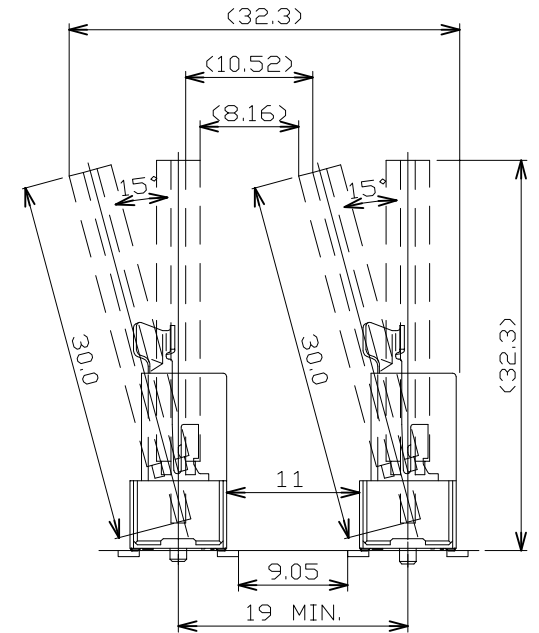

A

A

B

B

mat'l. code		-		surface		- ✓		tolerance		ASME_Y14.5		projection		product family		DDR4	
ltr	ecn no	dr	date	tolerances unless otherwise specified								MM		title			
				angles	Linear	.02±0.30								DDR4_SODIMM_VERTICAL			
				±2'	Linear	.00±0.20								STD_260PIN			
					Linear	.000±0.10								dwg no		sheet 2 of 5	
				dr	WINSTON_ZHU	2022-04-13								10153311		size	
				enr	ZHENHUA_LIU	2022-04-13										A4	
				chr	LONG_QUAN	2022-04-13											
				appd	HEAVEN_CEN	2022-04-13											
sheet index		revision sheet		B													

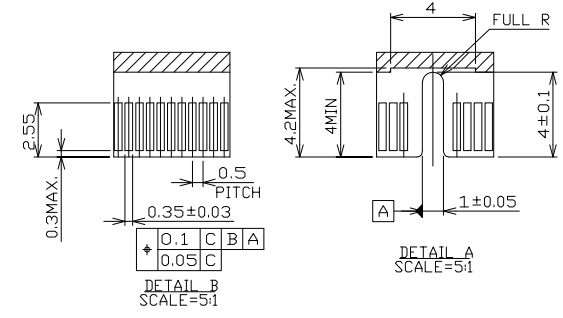
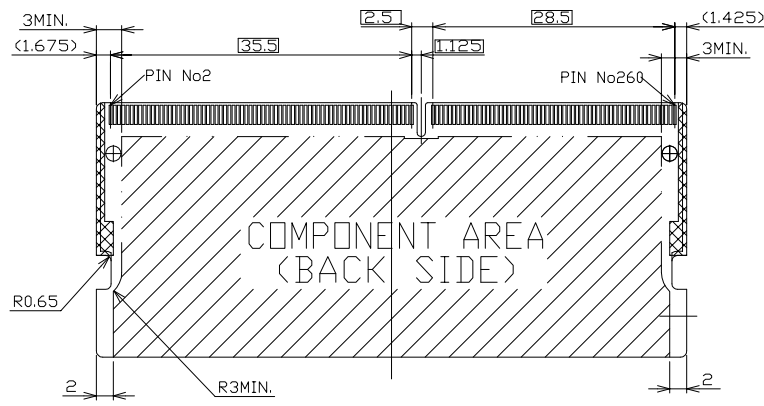
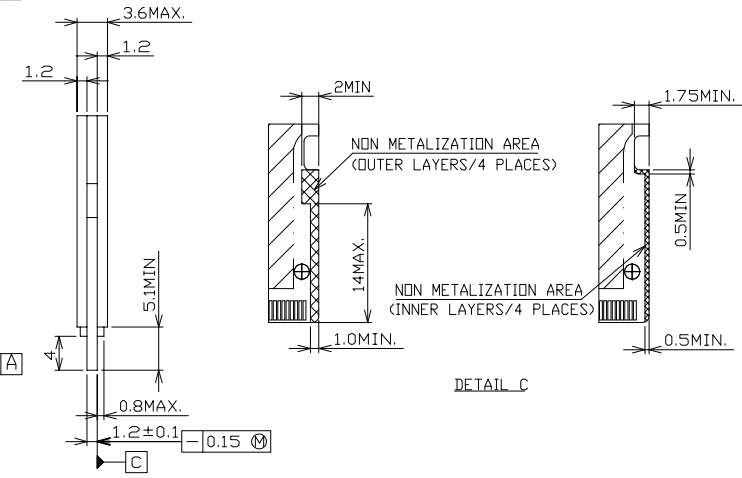
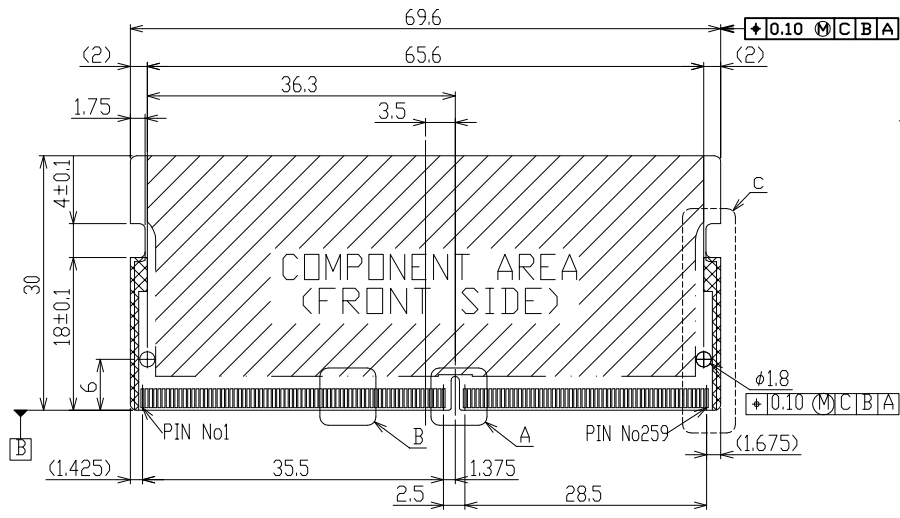

NOTES.
1 TOLERANCE ON DIMENSIONS IS ±0.15 UNLESS OTHERWISE SPECIFIED.

mat'l. code		-		surface		- ✓		tolerance		ASME_Y14.5		projection		product family		DDR4	
lfr		ecn no		dr		date		tolerances unless otherwise specified		MM		title		DDR4_SODIMM_VERTICAL		STD_260PIN	
								angles		Linear		scale N/A		dwg no		sheet 3 of 5 size	
								±2'		.0±0.30		Amphenol FCi		10153311		A4	
				dr		WINSTON_ZHU		2022-04-13		.00±0.20				type		CUSTOMER Drawing	
				engr		ZHENHUA_LIU		2022-04-13		.000±0.10							
				chr		LONG_QUAN		2022-04-13									
				appd		HEAVEN_CEN		2022-04-13									
sheet index		revision sheet		B													

SOFT TRAY

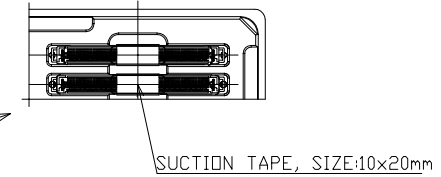
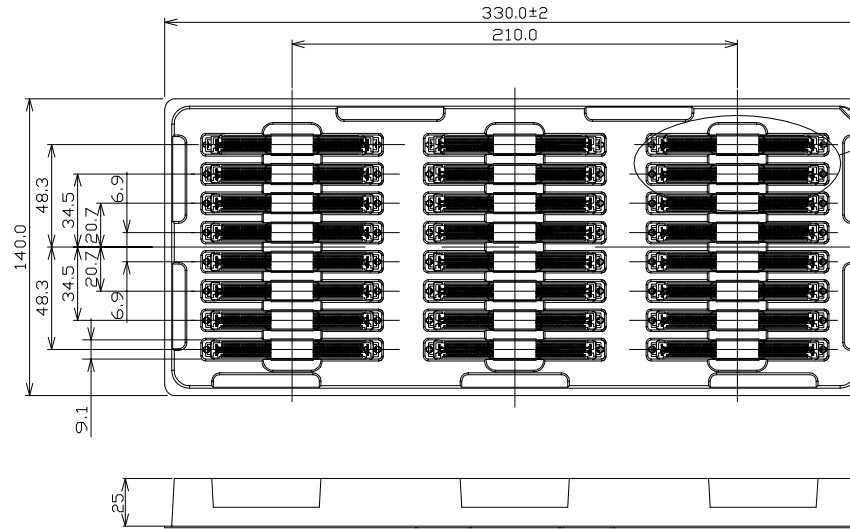

1.DIMENSION:(mm)

- a>TRAY: L=330、 W=140、 H=25.0
- b>Inner CARTON: L=360、 W=170、 H=140
- c>Outer CARTON: L=530、 W=370、 H=180

2.QUANTITY:

- a> 24 PCS/TRAY
- b> 4 TRAY/SHEAF(96 pcs)
- c> 1 SHEAF/Inner CARTON(96 pcs)
- d> 3 Inner CARTON / Outer CARTON(288PCS)

3.The tolerance of Mylar is ±2mm

mat'l. code		-		surface	-	tolerance	ASME_Y14.5	projection	product family	DDR4	
ltr	ecn no	dr	date	tolerances unless otherwise specified				MM	title		
				angles	linear	.0±0.30	Amphenol FCi		DDR4_SODIMM_VERTICAL		
				±2'	linear	.00±0.20		scale N/A	STD_260PIN		
				dr	WINSTON_ZHU	2022-04-13	Amphenol FCi	dwg no		sheet 4 of 5	
				enfr	ZHENHUA_LIU	2022-04-13		10153311		size	A4
				chr	LONG_QUAN	2022-04-13		type		CUSTOMER Drawing	
				appc	HEAVEN_CEN	2022-04-13					
sheet index	revision sheet	B									

HARD TRAY

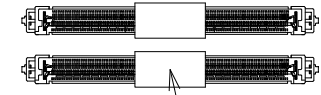
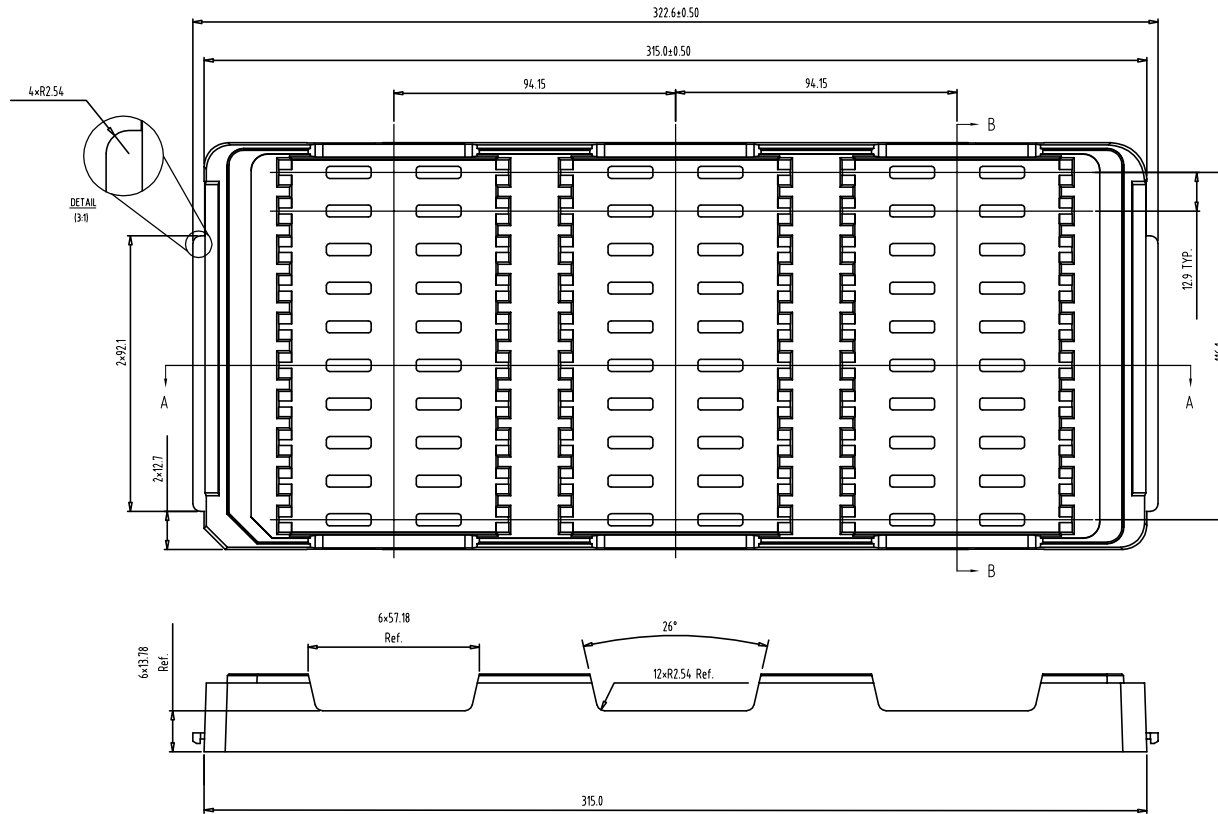

SUCTION TAPE, SIZE:10x20mm

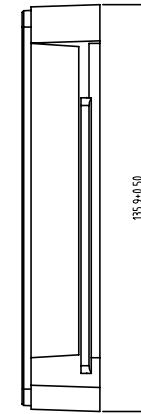

1.DIMENSION:(mm)

- a>TRAY: L=322.6、 W=135.9、 H=26.0
- b>Inner CARTON: L=360、 W=170、 H=140
- c>Outer CARTON: L=530、 W=370、 H=180

2.QUANTITY:

- a> 30 PCS/TRAY
- b> 4 TRAY/SHEAF(120 pcs)
- c> 1 SHEAF/Inner CARTON(120 pcs)
- d> 3 Inner CARTON / Outer CARTON(360PCS)

3.The tolerance of Mylar is ±2mm

Note: Material:ABS Color:Black

mat'l. code		surface		tolerance		projection		product family	
-		-		ASME_Y14.5		⊕		DDR4	
ltr		ecn no		dr		date		title	
								DDR4_SODIMM_VERTICAL	
								STD_260PIN	
								dwg no	
								sheet 5 of 5	
								size	
								A4	
								type	
								CUSTOMER Drawing	
sheet index		revision sheet		B					