

- NFS25 and NFS40
- Assembly instructions
- Mounting screws
- Crimp terminals and mating connectors

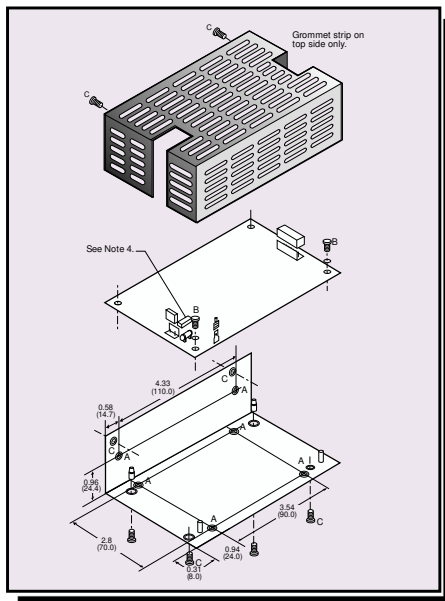

MECHANICAL SPECIFICATIONS

NFS25 and NFS40



Assembly Notes

- 1 Before assembly, ensure unit has been turned off for at least 10 minutes.
- 2 Cover cable exit area with grommet strip provided.
- 3 Maximum screw penetration into customer mounting holes is 3mm.
- 4 Cover fuse with fuse cover provided.
- 5 "A" denotes customer M3 mounting holes.
- 6 "B" denotes PCB fixing screws.
- 7 "C" denotes case assembly points and screws.

Note: When a cover or other sheetmetal option is added, it is the user's responsibility to ensure that the requirements of the relevant safety agency, or agencies, are satisfied.

MODEL NUMBER: NFS40 COVER KIT

Bracket outside dim. 5.49" x 3.43" x 1.88" (139.5 x 87.2 x 47.9mm)

Cover outside dim. 5.49" x 3.38" x 1.82" (139.5 x 85.8 x 46.3mm)

- NFS110
- Assembly instructions
- Mounting screws
- Crimp terminals and mating connectors

The 'NFS110 COVER KIT' is manufactured in Europe with metric screw threads and the kit includes assembly screws and installation instructions.

MECHANICAL SPECIFICATIONS

NFS110

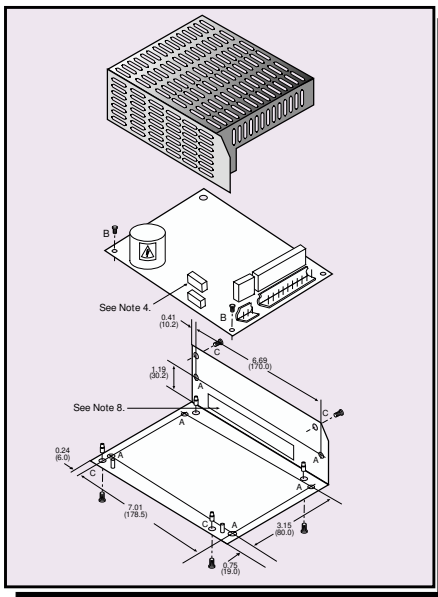

Assembly Notes

- 1 Before assembly, ensure unit has been turned off for at least 10 minutes.
- 2 Cover cable exit area with grommet strip provided (optional). Not required for the NFS110.
- 3 Maximum screw penetration into customer mounting holes is 3mm.
- 4 Cover fuse with fuse cover provided.
- 5 "A" denotes customer M3 mounting holes.
- 6 "B" denotes PCB fixing screws.
- 7 "C" denotes case assembly points and screws.
- 8 Apply tape in location shown.
- 9 Dimensions are in inches (mm).

Note: When a cover or other sheetmetal option is added, it is the user's responsibility to ensure that the requirements of the relevant safety agency, or agencies, are satisfied.

MODEL NUMBER: NFS110 COVER KIT

Bracket outside dim: 7.5" x 4.57" x 2.38" (190.5 x 116 x 60.5mm)

Cover outside dim: 7.5" x 4.51" x 2.32" (190.5 x 114.5 x 59mm)

- NFS110 cover
- Assembly instructions
- Mounting screws

The 'NFS110C' is manufactured in Asia with imperial screw threads and the kit includes assembly screws and installation instructions.

MECHANICAL SPECIFICATIONS

NFS110

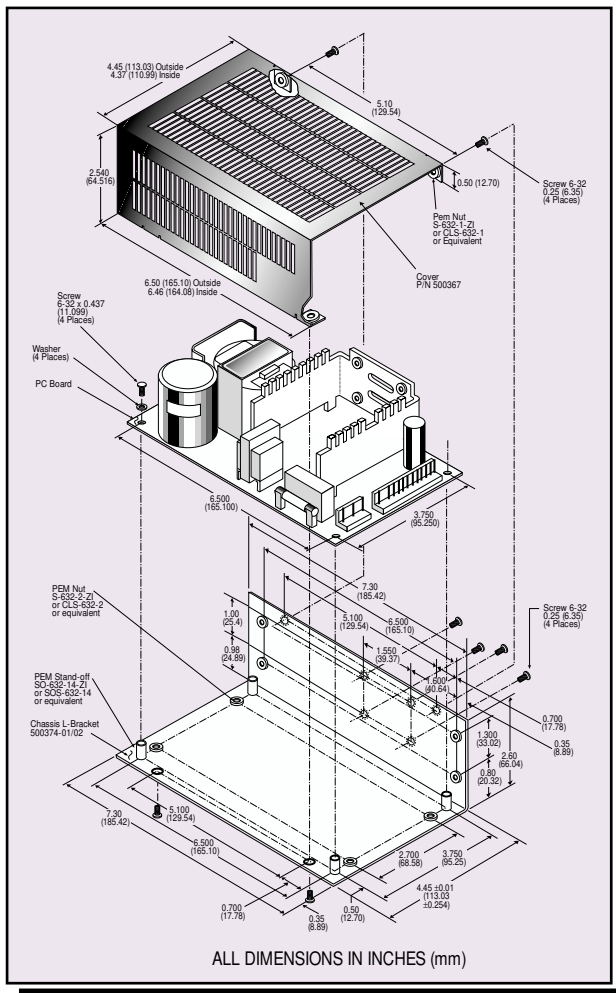

MODEL NUMBER: NFS110C

Bracket outside dim: 7.3" x 4.45" x 2.6" (185.42 x 113.03 x 66.04mm)
 Cover outside dim: 6.5" x 4.45" x 2.54" (165.10 x 113.03 x 64.52mm)