

PRODUCT DATA DRAWING

REVISION HISTORY			
REV	DESCRIPTION	DATE	APPROVED
C	DCN 43277	04/17	MAL

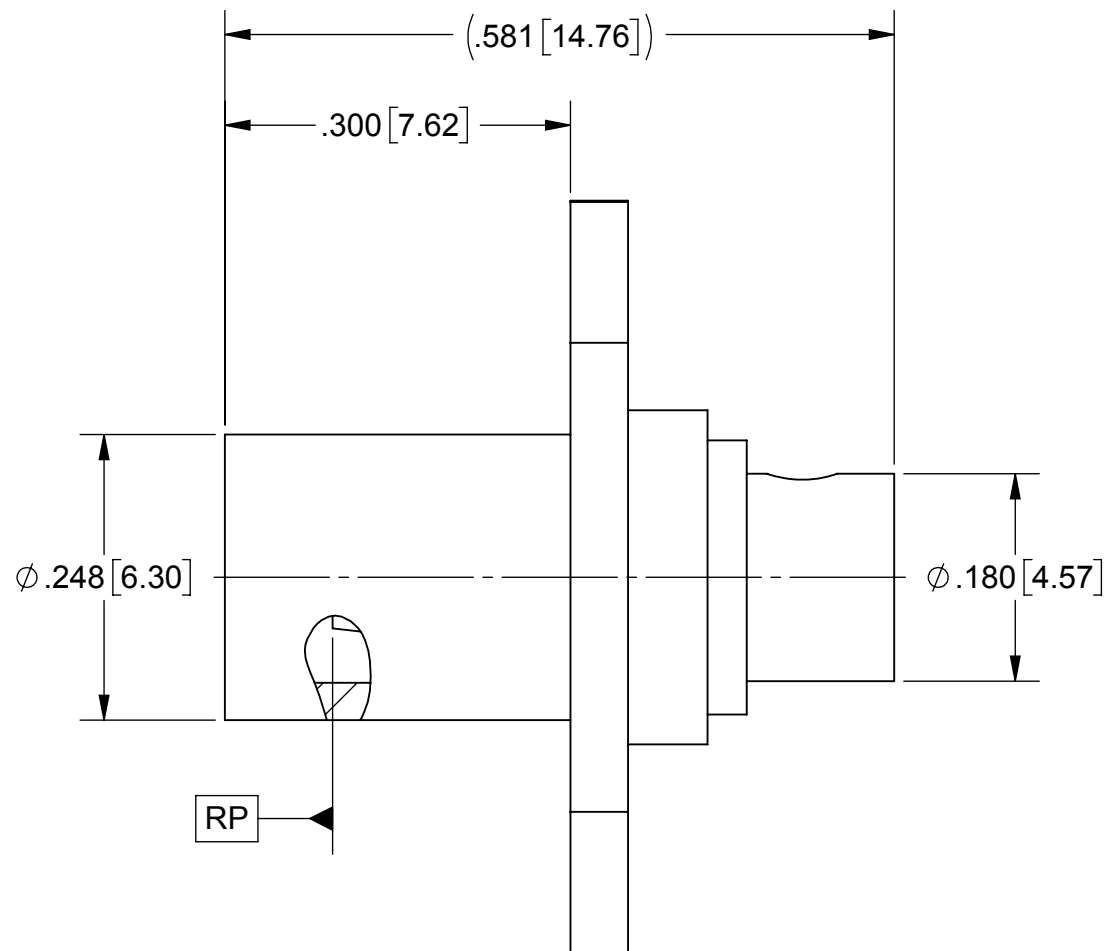
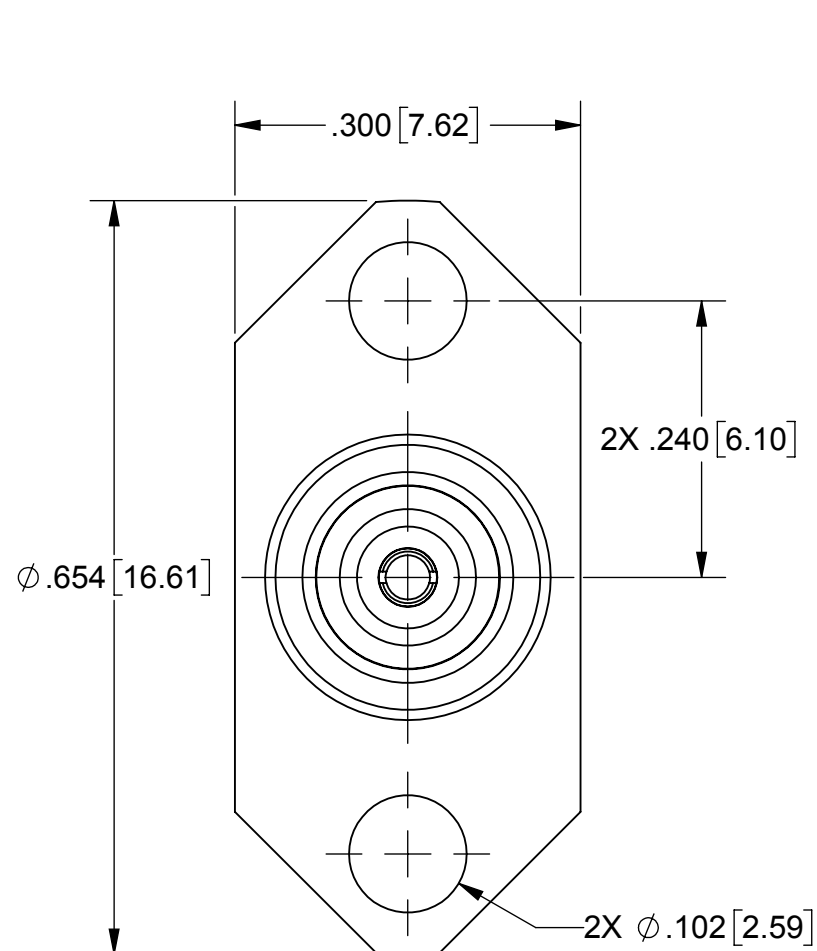

MATERIAL:

- BODY:** STAINLESS STEEL PER AMS-5640, ALLOY UNS S30300, TYPE 1
- CONTACT:** BERYLLIUM COPPER PER ASTM B196, ALLOY No. UNS C17300, TD04
- INSULATOR:** PTFE PER ASTM D1710, TYPE I, GRADE 1, CLASS B
- GASKET:** SILICONE RUBBER PER A-A-59588, CLASS 2B, GRADE 60/70

FINISH:

FRONT BODY: PASSIVATED PER AMS-2700

READ BODY & CONTACT:

GOLD PER ASTM B488, TYPE II, CODE C, CLASS 1.27, OVER NICKEL PER AMS-QQ-N-290, CLASS 1, .00005" MIN.

PERFORMANCE:

IMPEDANCE: 50 OHMS
FREQ. RANGE: DC TO 2.0 GHz.

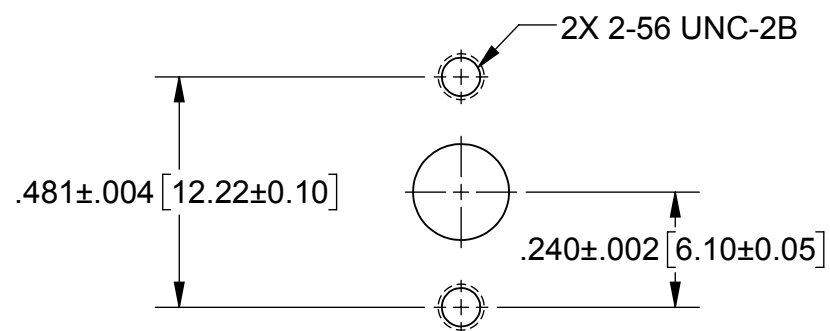

RECOMMENDED MOUNTING HOLE

MATERIAL: SEE NOTES	DIMENSIONS ARE IN INCHES TOLERANCES: FRACTIONAL: ±1/64 ANGULAR: X° ±1°0' X'X' ±15'	UNLESS OTHERWISE SPECIFIED 1) ALL DIMENSIONS ARE IN INCHES (MILLIMETERS) 2) ALL DIMENSIONS ARE AFTER PLATING. 3) BREAK CORNERS & EDGES .005 R. MAX. 4) CHAM. 1ST & LAST THREADS. 5) SURFACE ROUGHNESS 63 MIL-STD-10. 6) DIA.'S ON COMMON CENTERS TO BE CONCENTRIC WITHIN .005 T.I.R. 7) REMOVE ALL BURRS	 2400 Centrepark West Drive, Suite 100 West Palm Beach, FL 33409 TITLE: BZ HIGH POWER JACK, 2 HOLE FLANGE MOUNT TO .141 S.R. CABLE
FINISH: SEE NOTES	DECIMAL: X ±.030 .XX ±.010 .XXX ±.005	INTERPRET DIMENSIONS AND TOLERANCES PER ASME Y14.5M - 1994	
SURFACE AREA: N/A	THIRD ANGLE PROJECTION	DRAWN: VB 04/03/17	SIZE: B CAGE CODE: 95077 DWG. NO. SF8835-6000
PROPRIETARY THE INFORMATION CONTAINED IN THIS DRAWING IS THE SOLE PROPERTY OF SV MICROWAVE, INC. ANY REPRODUCTION IN PART OR AS A WHOLE WITHOUT THE WRITTEN PERMISSION OF SV MICROWAVE, INC IS PROHIBITED.		CHECKED: MAL 04/03/17	SCALE: 4:1
		APPROVED: MAL 04/03/17	SHEET 1 OF 1