

PRODUCT NUMBER

10129381 - X YY XXX X XF

- LEAD OR HALOGEN FREE OPTION (SEE NOTES 7)
- PACKAGING OPTIONS (SEE NOTE 3)
- INDICATES DIFFERENT MATING LENGTH TAIL LENGTH AND OTHER OPTIONS (SEE TABLE IN SHEET 2)
- NO OF POSITIONS (SEE NOTE 2)
- PIN PLATING (SEE SHEET 2)
- BASE PART NO.

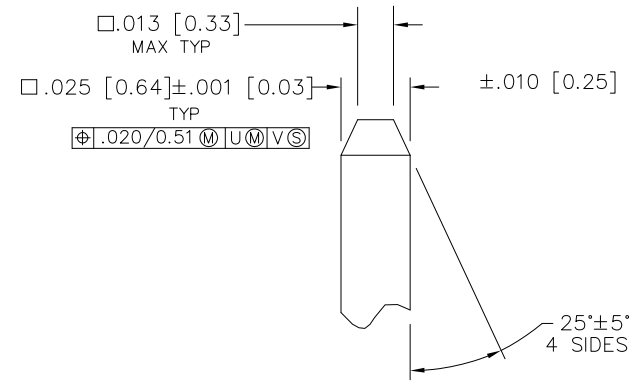
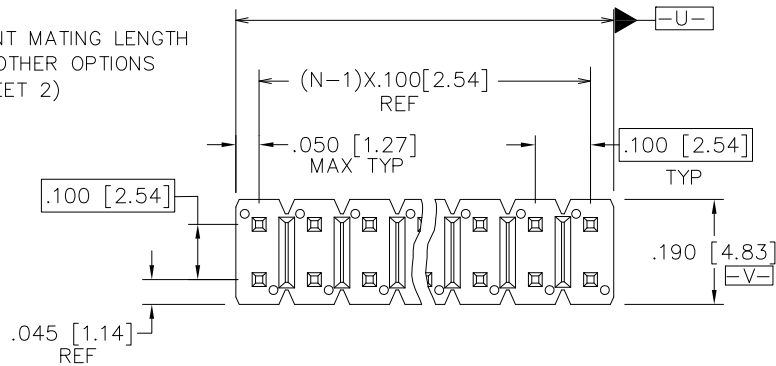

DETAIL P
SCALE 5:1
TYP BOTH ENDS

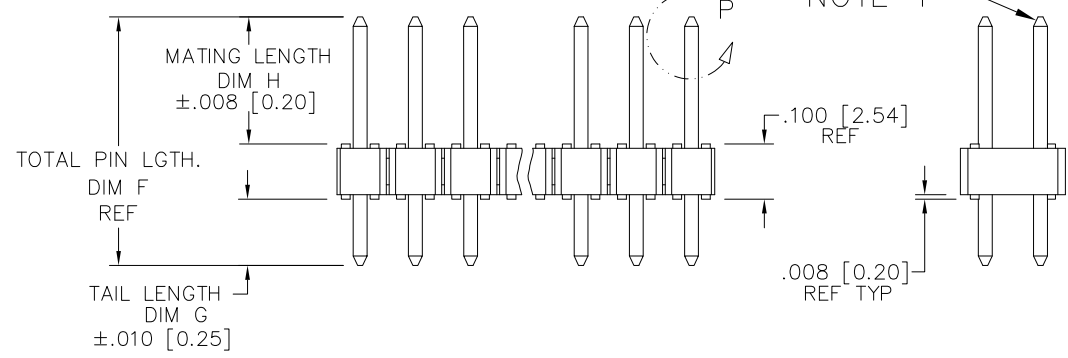

NOTE 6

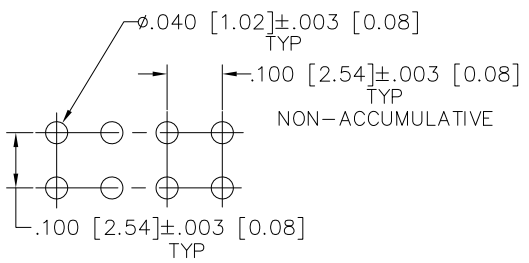

RECOMMENDED HOLE PATTERN

mat'l. code				surface ISO 1302 ✓		tolerance ISO 406 ISO 1101		projection		product family ECONOSTIK		
ltr	ecn no	dr	date	tolerances unless otherwise specified				INCH/mm		title		
A	NEW	ZK	04/23/14	angles	linear	.xxx±0.01/0.3		scale 2:1		ECONOSTIK HEADER		
B	ELX-N-18529	ZK	08/14/14			.xxx±0.008/xx±0.20				.100/2.54cc DR STRAIGHT		
C	ELX-N-20259	J.H	02/12/15	X±2'		.xxx±0.004/xxx±0.10				dwg no		
D	ELX-N-42423	MK	09/18/21	dr	ZK HU	04/23/14				sheet 1 of 2		
E	ELX-N-45076	MK	06/23/22	enr	MK XUAN	06/23/22				size		
				chr	LQ LEI	06/23/22				10129381		
				appd	TIM YAO	06/23/22				A4		
sheet index		revision sheet		E	E					type Product Customer Drawing		
				1	2							

PRODUCT NUMBER	TOTAL PIN LENGTH		TAIL LENGTH		MATING LENGTH	
	DIM F	DIM F	DIM G	DIM G	DIM H	DIM H
	ENGLISH	METRIC	ENGLISH	METRIC	ENGLISH	METRIC
10129381-XYY001XXF	0.450	11.43	0.120	3.05	0.230	5.84
10129381-XYY002XXF	0.420	10.67	0.090	2.29	0.230	5.84
10129381-XYY003XXF	0.538	13.67	0.120	3.05	0.318	8.08
10129381-XYY004XXF	0.508	12.91	0.090	2.29	0.318	8.08
10129381-XYY005XXF	0.966	24.54	0.354	9.00	0.512	13.00
10129381-XYY006XXF	0.832	21.14	0.110	2.80	0.622	15.8

PIN PLATING CODES:	
10129381-2YYXXXXXF	15u"/0.38um MIN Au CON CONTACT AREA OVER 50u"/1.27u MIN Ni
10129381-4YYXXXXXF	100u"/2.54um MIN Sn OVER 50u"/1.27u MIN Ni
10129381-9YYXXXXXF	GOLD FLASH PLATING OVER 50u"/1.27u MIN Ni

NOTES:

- MATERIAL
 BODAY MATERIAL: HIGH TEMPERATURE THERMOPLASTIC.
 FLAME UL94-V0, BLACK.
 PIN MATERIAL: COPPER ALLOY.
- ANY NUMBER OF POSITIONS FROM 4(2X2) TO 72(2X36).
 PRODUCT MAYBE CUTTING TO POSITION,
 THE CUTTING PLASH IS 0.02[0.51] MAX.
- PACKING STYLE DEFINITION.
 B: PACKED WITH POLY BAG
 T: PACKED WITH TUBE
 A: PACKED WITH TAPE AND REEL WITH PICK UP CAP
 C: PACKED WITH TAPE AND REEL WITHOUT PICK UP CAP
- TWO SIDES OF PIN TIPS NOT PLATED, TYPICAL BOTH ENDS.
- 2LBS/0.9KG MIN PIN RETENTION IN EITHER DIRECTION BEFORE REFLOW.
- THE OAL DON'T EXCEED 1 INCH / 25.4MM.
- LF = ADD LF AT THE END OF PART NUMBER IS FOR LEAD FREE.
 HF = ADD HF AT THE END OF PART NUMBER IS FOR HALOGEN FREE.
- THESE PRODUCT MEETS EUROPEAN UNION DIRECTIVES AND OTHER
 COUNTRY REGULATION AS DESCRIBED IN GS-22-008.
- PRODUCT SPECIFICATION: GS-12-1223.
- THIS PRODUCT WILL WITHSTAND EXPOSURE TO 260°C PEAK TEMPERATURE
 FOR 20 SECONDS IN WAVE SOLDER, INFRA-RED OR VAPOR PHASE SOLDER
 PROCESS.

Amphenol FCI

© 2016 AFCI

mat'l. code		surface ISO 1302 ✓		tolerance ISO 406 ISO 1101		projection 		product family ECONOSTIK	
ltr	ecn no	dr	date	tolerances unless otherwise specified		INCH/mm		title	
E				angles	linear	.xx±0.01/0.3 .xxx±0.008/xx±0.20 .xxxx±0.004/xxxx±0.10		ECONOSTIK HEADER .100/2.54cc DR STRAIGHT	
				X'±2'		scale 2:1		dwg no sheet 2 of 2 size	
				dr	ZK HU	04/23/14	Amphenol FCI	10129381 A4	
				enr	MK XUAN	06/23/22		type Product Customer Drawing	
				chr	LQ LEI	06/23/22			
				appd	TIM YAO	06/23/22			
sheet index	revision sheet								