

THIS DRAWING IS UNPUBLISHED. RELEASED FOR PUBLICATION
 © COPYRIGHT - By - ALL RIGHTS RESERVED.

Loc		DIST		REVISIONS					
GP		00		P	LTR	DESCRIPTION	DATE	DWN	APVD
				B1		REVISED PER ECO-11-004835	11MAR11	RK	HMR

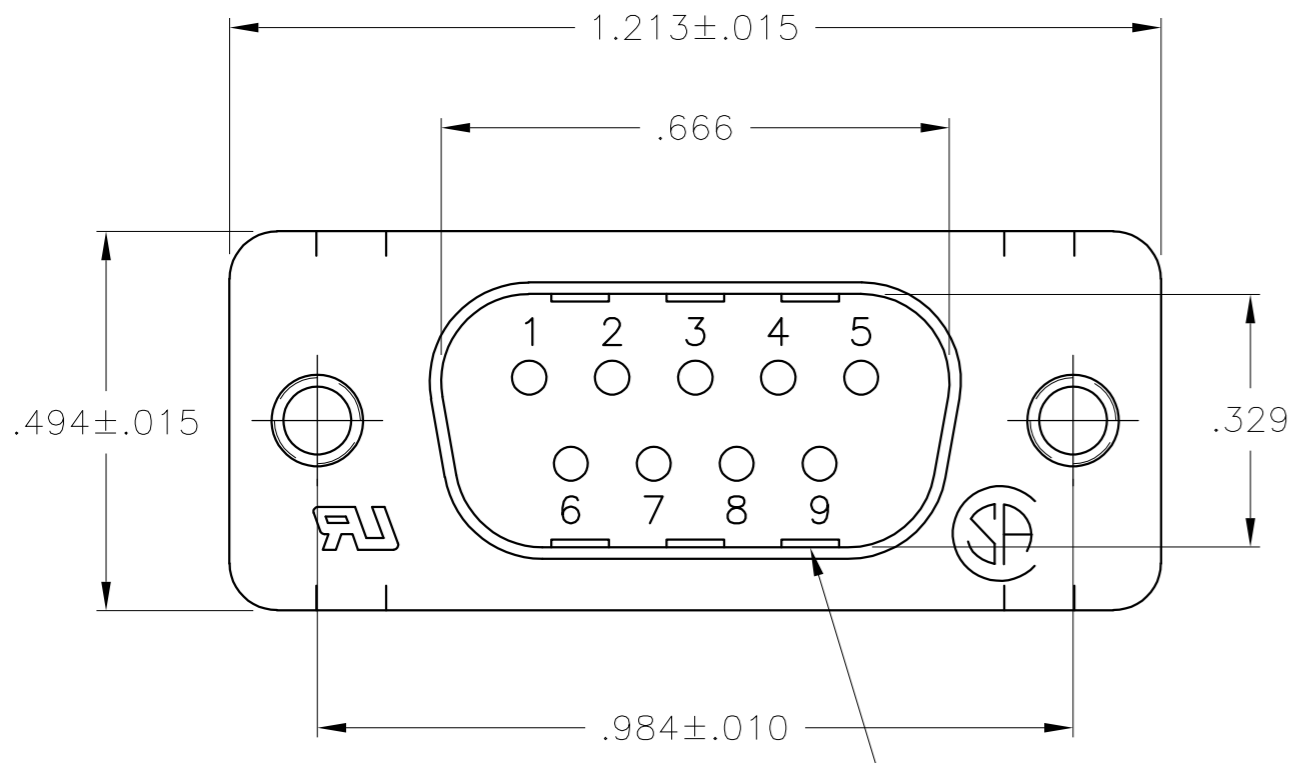

- ⚠ 1 HOUSING: FLAME RETARDENT THERMOPLASTIC, 94V-0 RATED, COLOR BLACK. SHELL: CARBON STEEL. CONTACTS: BRASS. INSERT/BOARDLOCKS: BRASS.
- ⚠ 2 SHELL: 0.00508[.000200] MIN TIN OVER 0.00254[.000100] MIN COPPER. CONTACTS: 0.00076 [0.000030] MIN GOLD ON MATING END, 0.00254 [0.000100] MIN TIN ON SOLDER END, ALL OVER 0.00127 [0.000050] MIN NICKEL ON ENTIRE CONTACT. -OR- GOLD FLASH OVER 0.00076 [0.000030] MIN PALLADIUM NICKEL ON MATING END, 0.00254 [0.000100] MIN TIN ON SOLDER END, ALL OVER 0.00127 [0.000050] MIN NICKEL ON ENTIRE CONTACT. INSERT/BOARDLOCKS: 0.00381[.000150] MIN TIN OVER 0.00254[.000100] MIN COPPER.
- ⚠ 3 POSITION NUMBERS SHOWN FOR REFERENCE ONLY.
- ⚠ 4 DATUMS AND BASIC DIMENSIONS TO BE ESTABLISHED BY CUSTOMER.
- 5. RECOMMENDED SCREWLOCK FOR #4-40 INSERT/BOARDLOCK IS 5747877-3.

TYCO, PART NUMBER & DATE CODE MARKED IN AREAS INDICATED, ON EITHER SIDE

GROUNDING INDENTS

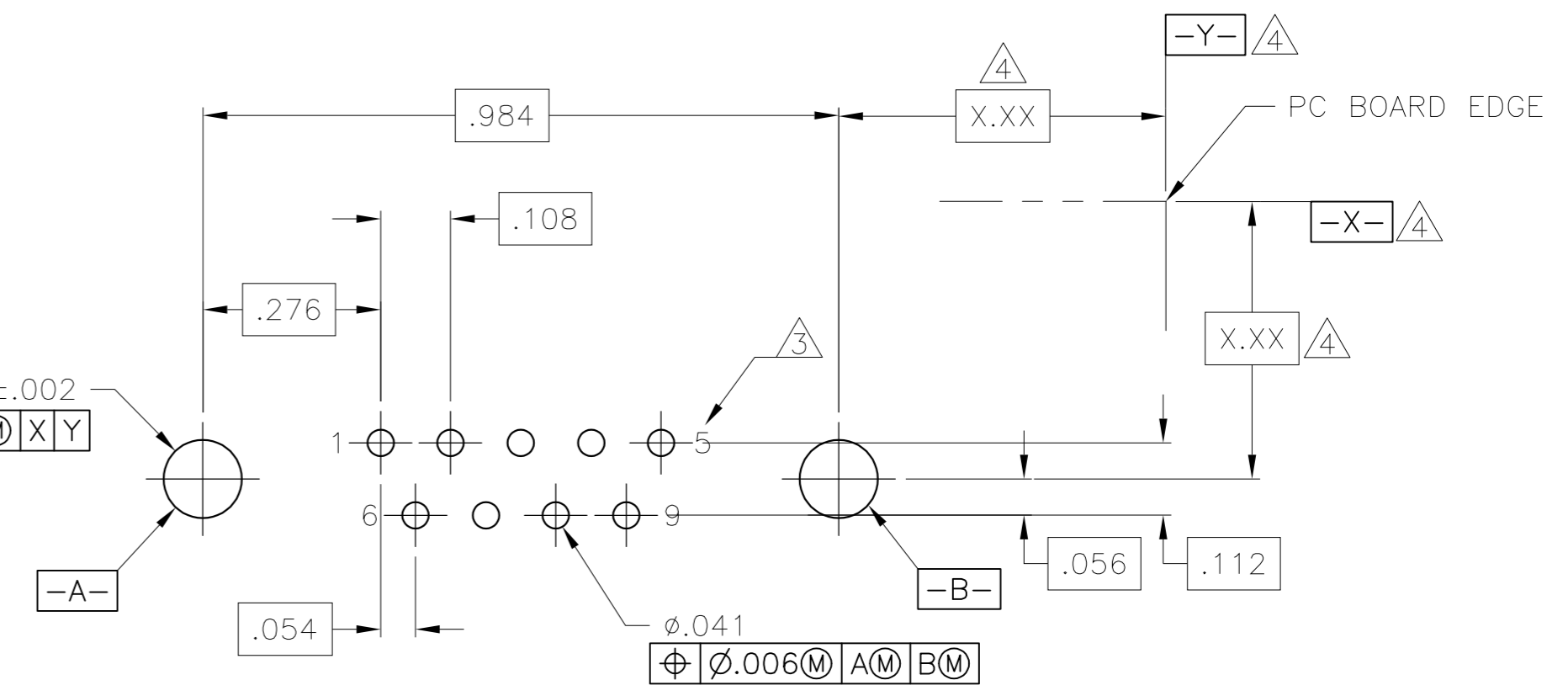
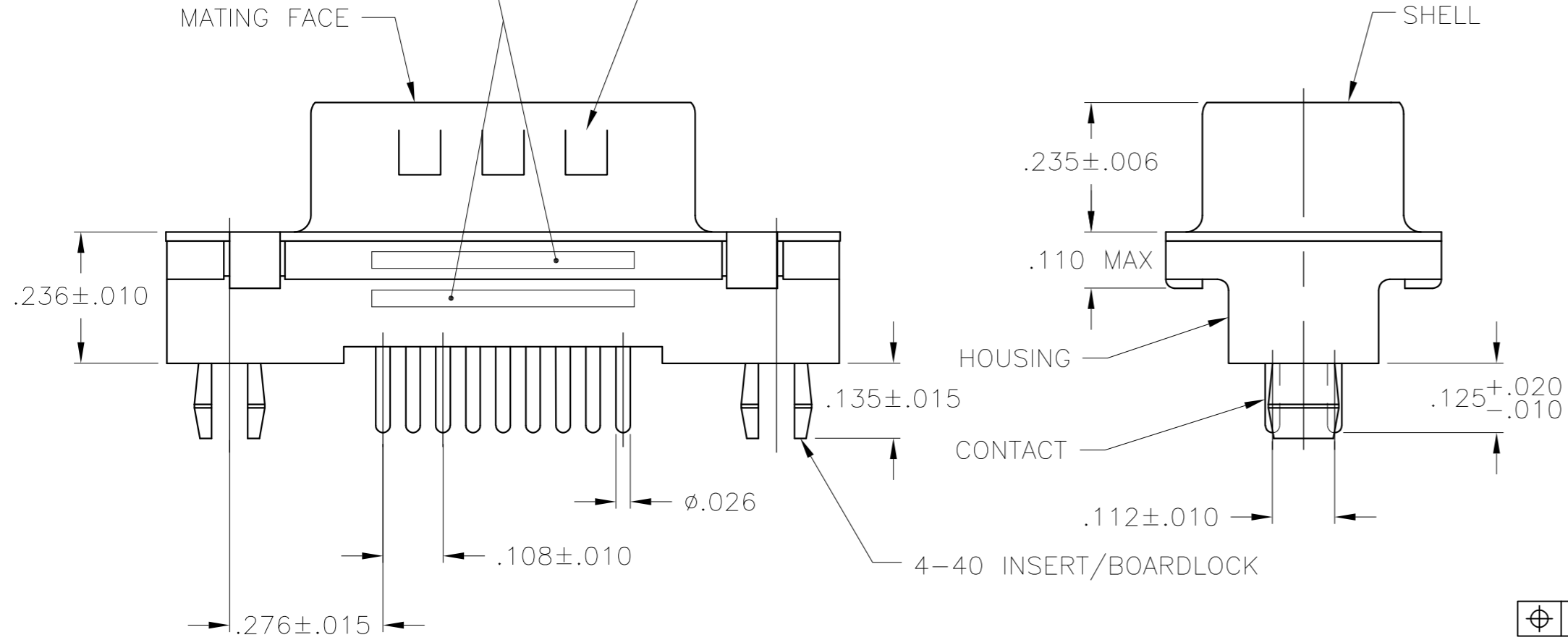

RECOMMENDED PC BOARD LAYOUT
 .062 PC BOARD
 (VIEWED FROM CONNECTOR SIDE)

2-5748003-0
 PART NUMBER

**COPYRIGHT 2005
 TE CONNECTIVITY CORP
 ALL RIGHTS RESERVED**

THIS DRAWING IS A CONTROLLED DOCUMENT.		DWN	J.GERACE	23MAR05	TE Connectivity				
DIMENSIONS:	TOLERANCES UNLESS OTHERWISE SPECIFIED:	CHK	S.BOLASH	23MAR05					
INCHES		APVD	M.WALMSLEY	23MAR05	NAME				
	0 PLC ± -	PRODUCT SPEC		108-40025		SIZE	CAGE CODE	DRAWING NO	RESTRICTED TO
	1 PLC ± -	APPLICATION SPEC		114-40023		A2	00779	C=5748003	-
	2 PLC ± -					SCALE			SHEET
	3 PLC ± 0.13[.005]					4:1			1 of 1
4 PLC ± -					CUSTOMER DRAWING				
ANGLES ± -									
FINISH									
MATERIAL									