

PRODUCT NUMBER
SEE TABLE

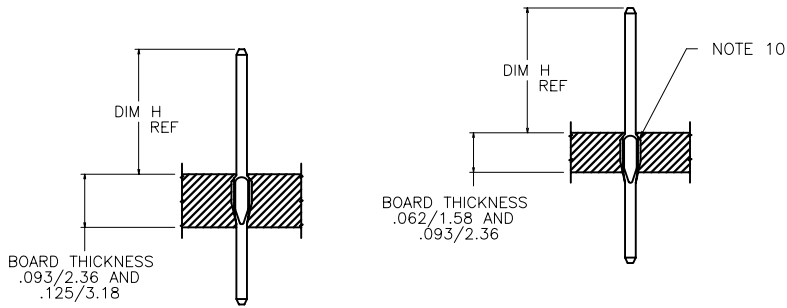

BOARD THICKNESS
.062/1.58 AND
.093/2.36

NOTE 10

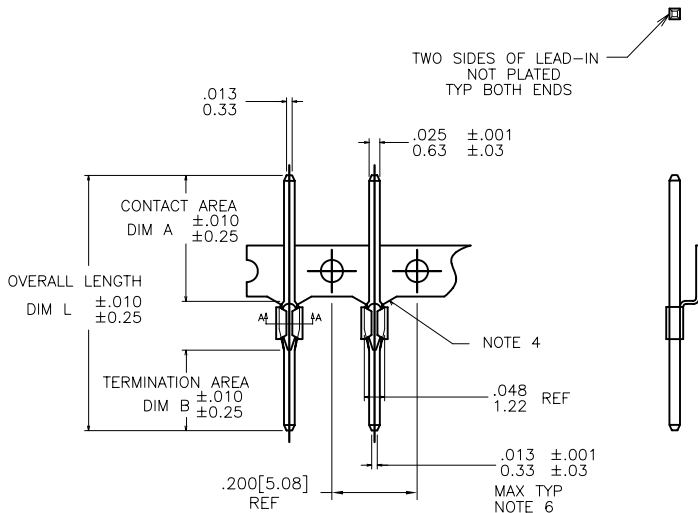

TWO SIDES OF LEAD-IN
NOT PLATED
TYP BOTH ENDS

NOTE 4

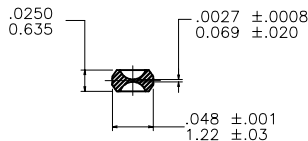

SECTION A-A
WITH FERRULE REMOVED
SCALE 20/1

NOTES:

- ① TERMINAL MAT'L: 3/4 PHOS BRONZE ALLOY PER UNS-C51000, ASTM B-159-66.
2. BURNISH MARKS ON PIN PERMITTED.
3. PC BOARD HOLE SIZE .040+.003,-.000,
1.02+0.08,-0.00
RECOMMENDED DRILLED HOLE SIZE
.0453±.001/1.151±.03
WITH Cu PLATING THICKNESS
.001/.03 MIN .002/.05
MAX SnPb PLATING THICKNESS .0004/.010
IT IS SUGGESTED THAT LUBE BE APPLIED TO
PINS WITH TIN PLATING BEFORE INSERTION.
- ④ FOR MANUFACTURING PURPOSES ONLY.
5. .003/.08 R MAX TYP 4 PLACES
ON WIRE WRAP PORTION OF PIN.
- ⑥ IF DIM B IS .235/5.97 OR LESS THE
MAX FLAT MAY BE .016/.41
7. PRODUCT INFORMATION
XXXXX-XXXLF
BASE P/N LEAD FREE OPTION
NO. FOR LENGTH VARIATION
PLATING SEE TABLE
8. SEE BUS-24-001 FOR SUPER TIP DESIGN.
- ⑨ BOW SPEC TO BE HELD TO .005/0.13
ALONG LENGTH OF PIN.
- ⑩ MINI LIF FEATURE TO BE CENTERED IN BOARD.
- ⑪ ADD AN LF SUFFIX TO PART NUMBER FOR PRODUCT
THAT MEETS EUROPEAN UNION DIRECTIVES AND OTHER
COUNTRY REGULATIONS AS DESCRIBED IN GS-22-008.
- ⑫ THIS PRODUCT HAS 100% TIN PLATING IN THE
INTERFACE AND HAS NOT BEEN TESTED FOR WHISKER
GROWTH IN ALL INTERCONNECT ENVIRONMENTS.

mat'l. code				surface		tolerance		projection		product family	
NOTE 1				ASME Y14.5		ASME Y14.5		INCH/MM		PIN PRODUCTS	
ltr	ecr no	dr	date	tolerances unless otherwise specified				title			
AM	V07-0516	HTB	2007-08-08	angles	XX ±01/X±3		INCH/MM		COMPLIANT PRESS FIT PIN		
-	-	-	-	fil	XXX ±005/XX±13		scale 3:1		.200/5.08 cc		
AG	V61463	HTB	1998-08-28	0' ±2'	XXXX ±0020/XXX±051		scale 3:1		dwg no sheet 1 of 3 size		
AH	V90053	SAR	1999-01-22	dr	J.W. BAIR	1990-03-01	FCI		76230 A4		
AJ	V01594	JRW	2000-07-12	engr	K.D. PATEL	1990-03-01			CUSTOMER Drawing		
AK	V05-0416	HTB	2005-05-02	chr	E. IORFIDO	1990-03-01					
AL	V06-0684	HTB	2006-07-24	apdd	E. IORFIDO	1990-03-01					
sheet	revision	AM	AM	AM							
index	sheet	1	2	3							



PRODUCT NUMBER NOTE 11	CONTACT AREA DIM A	TERMINATION AREA DIM B	DIM. H .093/2.36 TO .125/3.18 BD	OVERALL LENGTH DIM L
76230-X01	.205/5.21	.055/1.40	.195/4.95	.375/9.53
76230-X02	.230/5.84	.050/1.27	.220/5.59	.395/10.03
76230-X03	.260/6.60	.055/1.40	.250/6.35	.430/10.92
76230-X04	.320/8.13	.050/1.27	.310/7.87	.485/12.32
76230-X05	.320/8.13	.220/5.59	.310/7.87	.655/16.64
76230-X06	.330/8.38	.285/7.24	.320/8.13	.730/18.54
76230-X07	.345/8.76	.050/1.27	.335/8.51	.510/12.95
76230-X08	.345/8.76	.235/5.97	.335/8.51	.695/17.65
76230-X09	.345/8.76	.320/8.13	.335/8.51	.780/19.81
76230-X10	.345/8.76	.350/8.89	.335/8.51	.810/20.57
76230-X11	.390/9.91	.055/1.40	.380/9.65	.560/14.22
76230-X12	.390/9.91	.395/10.03	.380/9.65	.900/22.86
76230-X13	.420/10.67	.050/1.27	.410/10.41	.585/14.86
76230-X14	.425/10.80	.085/2.16	.415/10.54	.625/15.88
76230-X15	.425/10.80	.315/8.00	.415/10.54	.855/21.72
76230-X16	.500/12.70	.060/1.52	.490/12.45	.675/17.15
76230-X17	.505/12.83	.335/8.51	.495/12.57	.955/24.26
76230-X18	.540/13.72	.415/10.54	.530/13.46	1.070/27.18
76230-X19	.545/13.84	.055/1.40	.535/13.59	.715/18.16
76230-X20	.555/14.10	.395/10.03	.545/13.84	1.065/27.05
76230-X21	.595/15.11	.335/8.51	.585/14.86	1.045/26.54
76230-X22	.600/15.24	.055/1.40	.590/14.99	.770/19.56
76230-X23	.635/16.13	.050/1.27	.625/15.88	.800/20.32
76230-X24	.635/16.13	.235/5.97	.625/15.88	.985/25.02
76230-X25	.635/16.13	.320/8.13	.625/15.88	1.070/27.18
76230-X26	.635/16.13	.350/8.89	.625/15.88	1.100/27.94
76230-X27	.635/16.13	.395/10.03	.625/15.88	1.145/29.08
76230-X28	.635/16.13	.640/16.26	.625/15.88	1.390/35.31
76230-X29	.690/17.53	.050/1.27	.680/17.27	.855/21.72
76230-X30	.720/18.29	.395/10.03	.710/18.03	1.230/31.24
76230-X31	.720/18.29	.725/18.42	.710/18.03	1.560/39.62
76230-X32	.730/18.54	.055/1.40	.720/18.29	.900/22.86
76230-X33	.315/8.00	.115/2.92	.305/7.75	.545/13.84
76230-X34	.560/14.22	.325/8.26	.550/13.97	1.000/25.40
76230-X35	.360/9.14	.325/8.26	.350/8.89	.800/20.32

PRODUCT NUMBER NOTE 11	PLATING	UNDERPLATING
76230-1YY	30μ"/.76μ MIN Au	50μ"/1.27μ MIN Ni
76230-1YYLF		
76230-3YY	50μ"/1.27μ MIN Au	50μ"/1.27μ MIN Ni
76230-3YYLF		
76230-4YY	120μ"/3.05μ MIN 93/7 SnPb	50μ"/1.27μ MIN Ni
76230-4YYLF	100μ"/2.54μ MIN Sn (NOTE 12)	50μ"/1.27μ MIN Ni
76230-5YY	30μ"/.76μ MIN GXT™	50μ"/1.27μ MIN Ni
76230-5YYLF		
76230-6YY	15μ"/.38μ MIN GXT™	50μ"/1.27μ MIN Ni
76230-6YYLF		
76230-9YY	15μ"/.38μ MIN Au	50μ"/1.27μ MIN Ni
76230-9YYLF		

DISCONTINUED

A

A

B

B

mat'l. code		surface		tolerance		projection		product family	
NOTE 1		ASME Y14.5		ASME Y14.5				PIN PRODUCTS	
ltr	ecn no	dr	date	tolerances unless otherwise specified				title	
AM				angles		INCH/MM		COMPLIANT PRESS FIT PIN	
				0° ±2'		scale 3:1		.200/5.08 cc	
				dr	J.W. BAIR	1990-03-01		dwg no	
				engr	K.D. PATEL	1990-03-01		sheet 2 of 3	
				chr	E. IORFIDO	1992-08-19		size	
				appd	E. IORFIDO	1992-08-19		A4	
sheet index	revision sheet							type CUSTOMER Drawing	



PRODUCT NUMBER NOTE 11	CONTACT AREA DIM A	TERMINATION AREA DIM B	DIM H .093/2.36 TO .125/3.18 BD	OVERALL LENGTH DIM L
76230-X36	.450/11.43	.345/8.76	.440/11.18	.910/23.11
76230-X37	.575/14.61	.050/1.27	.565/14.35	.740/18.80
76230-X38	.445/11.30	.590/14.99	.435/11.05	1.150/29.21
76230-X39	UNASSIGNED			
76230-X40	.225/5.72	.185/4.70	.215/5.46	.525/13.34
76230-X41	.530/13.46	.275/6.99	.520/13.21	.920/23.37
76230-X42	.445/11.30	.395/10.03	.435/11.05	.955/24.26
76230-X43	.550/13.97	.625/15.88	.540/13.72	1.290/32.77
76230-X44	.595/15.11	.550/13.97	.585/14.86	1.260/32.00
76230-X45	.250/6.35	.565/14.35	.240/6.10	.930/23.62
76230-X46	.290/7.37	.400/10.16	.280/7.11	.805/20.45
76230-X47	UNASSIGNED			
76230-X48	.320/8.13	.565/14.35	.310/7.87	1.000/25.40
76230-X49	.230/5.84	.370/9.40	.220/5.59	.715/18.16
76230-X50	.417/10.59	.368/9.35	.407/10.34	.900/22.86
76230-X51	.523/13.28	.548/13.92	.513/13.03	1.186/30.12
76230-X52	.415/10.54	.590/14.99	.405/10.29	1.120/28.45
76230-X53	.570/14.48	.050/1.27	.560/14.22	.735/18.67
76230-X54	.325/8.26	.590/14.99	.315/8.00	1.030/26.16
76230-X55	.415/10.54	.070/1.78	.405/10.29	.600/15.24
76230-X56	.520/13.21	.050/1.27	.510/12.95	.685/17.40
76230-X57	.615/15.62	.060/1.52	.605/15.37	.790/20.70
76230-X58	.417/10.59	.465/11.81	.407/10.34	.997/25.32
76230-X59	.455/11.56	.050/1.27	.445/11.30	.620/15.75
76230-X60	.225/5.72	.365/9.27	.215/5.46	.705/17.91
76230-X61	.650/16.51	.400/10.16	.640/16.26	1.165/29.59
76230-X62	.360/9.14	.055/1.40	.350/8.89	.530/13.46
76230-X63	.505/12.83	.510/12.95	.495/12.57	1.130/28.70
76230-X64	.665/16.89	.385/9.78	.655/16.64	1.165/29.59
76230-X65	.245/6.22	.345/8.76	.235/5.97	.705/17.91
76230-X66	.605/15.37	.065/1.65	.595/15.11	.785/19.93
76230-X67	.460/11.68	.422/10.72	.450/11.43	.997/25.32
76230-X68	.455/11.56	.040/1.02	.445/11.30	.610/15.49
76230-X69	.538/13.67	.533/13.54	.528/13.41	1.186/30.12
76230-X70	.460/11.68	.080/2.03	.450/11.43	.655/16.64

NOTE 9

PRODUCT NUMBER NOTE 11	CONTACT AREA DIM A	TERMINATION AREA DIM B	DIM H .093/2.36 TO .125/3.18 BD	OVERALL LENGTH DIM L
76230-X71	.388/9.86	.429/10.90	.378/9.60	.928/23.57
76230-X72	.428/10.87	.429/10.90	.418/10.62	.968/24.59
76230-X73	.375/9.53	.420/10.67	.350/8.89	.910/23.11
76230-X74	.415/10.54	.420/10.67	.390/9.91	.950/24.13
76230-X75	.455/11.56	.420/10.67	.430/10.92	.990/25.15
76230-X76	.825/20.96	.050/1.27	.815/20.70	.990/25.15
76230-X77	UNASSIGNED			
76230-X78	.764/19.41	.050/1.27	.754/19.15	.935/23.75
76230-X79	.205/5.21	.265/6.73	.220/5.59	.565/14.35
76230-X80	.215/5.46	.123/3.12	.205/5.21	.453/11.51

NOTE 10

A

A

B

B

mat'l. code		surface		tolerance		projection		product family	
NOTE 1		ASME Y14.5		ASME Y14.5				PIN PRODUCTS	
ltr	ecn no	dr	date	tolerances unless otherwise specified				title	
AM				angles				COMPLIANT PRESS FIT PIN	
				0° ±2'				INCH/MM	
				.XX ±.01/XX±3				scale 3:1	
				.XXX ±.005/XXX±13				sheet 3 of 3 size	
				.XXXX ±.0020/XXX±.051				76230 A4	
		dr	J.W. BAIR	1990-03-01				dwg no	
		engr	K.D. PATEL	1990-03-01				CUSTOMER Drawing	
		chr	E. IORFIDO	1992-08-19					
		appd	E. IORFIDO	1992-08-19					
sheet index	revision sheet								