

LOC	DIST	P	F	ZONE	LTR	DESCRIPTION	DATE	APPD	
DF	X0				D	REV PER OH14-0747-04	CT	11-2-04	RG

- 1 MAT'L: BRASS PER ASTM-B-16
- 2 MAT'L: BERYLLIUM COPPER PER ASTM-B-196.
- 3 MAT'L: PTFE PER ASTM-D-1710.
- 4 FINISH: GOLD PLATE PER ASTM-B-488, TYPE 1, GRADE C, CLASS 1 OVER NICKEL .000050 [0.0013] THK PER AMS-QQ-N-290, CLASS 2.
- 5 FINISH: PASSIVATE PER AMS-QQ-P-35.
- 6 COLOR CODED PER MIL-C-39029, .020-.050 [0.51-1.27] WIDTH.
- 7 160 DP. FULL DIAMOND KNURL OVER THIS LENGTH.
- 8 MAT'L: POLYESTER MLDG. CMPD. PER MIL-M-24519, TYPE C.
- 9 MAT'L: STAINLESS STEEL PER ASTM-A-240.

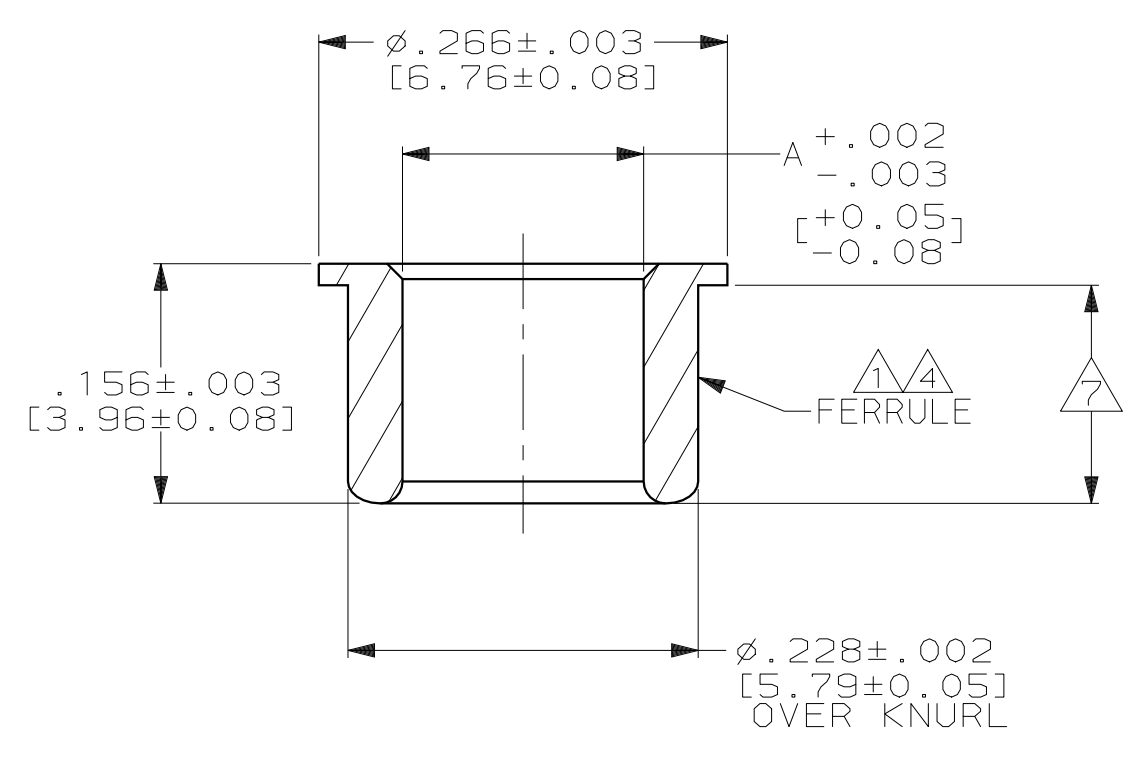

DETAIL A
FERRULE FOR 448543-1 & -2

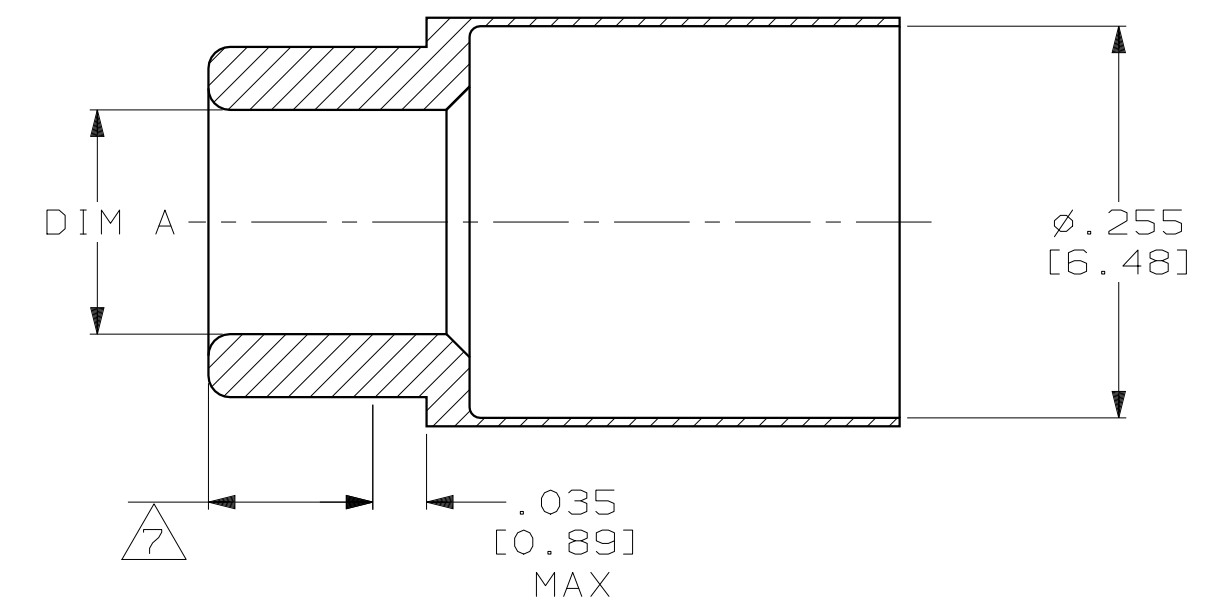

DETAIL B
FERRULE FOR 448543-3 ONLY

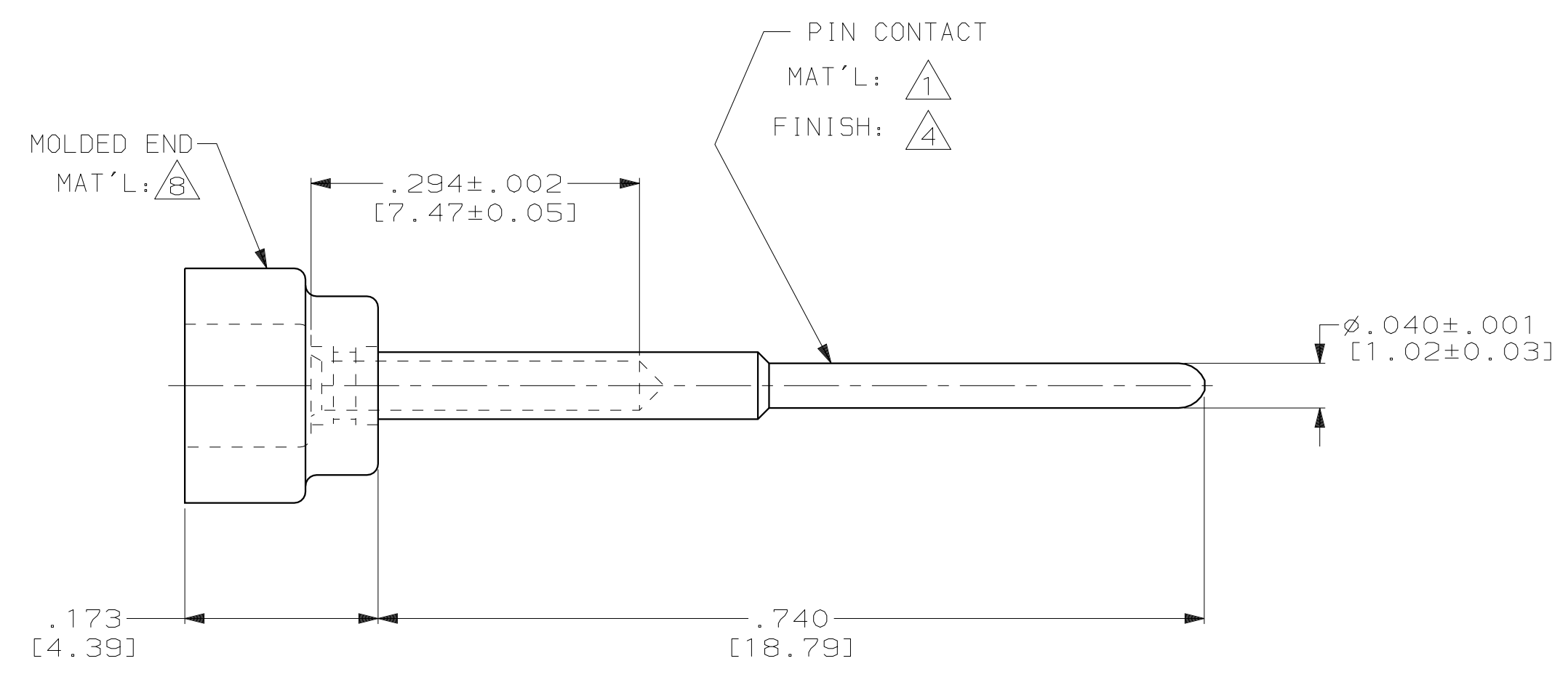

ASSEMBLY PROCEDURE FOR 448543-1 & 448543-2:

- STRIP OUTER INSULATION BACK FROM END OF CABLE .500 INCH.
- SLIDE OUTER FERRULE, LARGEST END FIRST, OVER CABLE JACKET.
- COMB OUT SHIELD. FOLD SHIELD BACK OVER KNURLED AREA OF FERRULE AND TRIM EVEN WITH BACK EDGE OF KNURLED AREA OF FERRULE. TRIM BRAID EVEN WITH BACK EDGE OF KNURLED AREA.
- TRIM THE DIELECTRIC TO EXPOSE APPROXIMATELY .300 INCH OF CENTER CONDUCTOR.
- PLACE THE PIN CONTACT SUB-ASSEMBLY INTO A M22520/2-01 CRIMPING TOOL, SIDE OPPOSITE THE SELECTOR SWITCH. THE PLASTIC HOUSING ON THE PIN CONTACT SERVES AS A LOCATOR. SET CRIMP TOOL SELECTOR SWITCH TO #5. INSERT CENTER CONDUCTOR INTO CONTACT INSURING CABLE DIELECTRIC ENTERS PLASTIC AND HOUSING AND CENTER CONDUCTOR IS VISIBLE THRU VIEW HOLE IN CENTER CONTACT. CRIMP CONTACT.
- SLIDE CRIMPED CONTACT SUB-ASSEMBLY INTO OUTER CONTACT BODY FIRMLY SEATING FERRULE. CRIMP FERRULE USING PROCRIMPER HANDTOOL #354940-1 AND LOCATOR 91907-1.

ASSEMBLY PROCEDURE FOR 448543-3

- STRIP OUTER INSULATION BACK FROM END OF CABLE 1.00 INCH.
- SLIGHTLY FLARE THE SHIELD AND TRIM APPROXIMATELY .25" OF THE DIELECTRIC, CENTER CONDUCTOR AND FILLER.
- SLIDE INNER CRIMP FERRULE, LARGEST END FIRST, OVER THE SHIELD UNTIL IT BOTTOMS ON THE OUTER INSULATION.
- COMB OUT SHIELD. FOLD SHIELD BACK OVER THE INNER CRIMP FERRULE. TRIM THE SHIELD EVEN WITH THE BACK EDGE OF THE KNURLED AREA.
- TRIM THE DIELECTRIC .10 INCH FROM THE SHIELD
- TRIM THE FILLER FLUSH WITH THE END OF THE DIELECTRIC.
- TRIM THE CENTER CONDUCTOR .30 INCH FROM THE END OF THE DIELECTRIC.
- PLACE THE OUTER CONTACT BODY OVER THE CENTER CONDUCTOR AND SLIDE IT OVER THE SHIELD. ENSURE THAT NO SHIELD STRANDS PROTRUDE FROM BETWEEN THE OUTER CONTACT BODY AND THE INNER CRIMP FERRULE.
- REMOVE THE OUTER CONTACT BODY AND TRIM THE SHIELD AS NEEDED.
- PLACE THE PIN CONTACT SUB-ASSEMBLY INTO A M22520/2-01 CRIMPING TOOL, SIDE OPPOSITE THE SELECTOR SWITCH. THE PLASTIC HOUSING ON THE PIN CONTACT SERVES AS A LOCATOR. SET CRIMP TOOL SELECTOR SWITCH TO #5. INSERT CENTER CONDUCTOR INTO CONTACT INSURING CABLE DIELECTRIC ENTERS PLASTIC AND HOUSING AND CENTER CONDUCTOR IS VISIBLE THRU VIEW HOLE IN CENTER CONTACT. CRIMP CONTACT.
- SLIDE CRIMPED CONTACT SUB-ASSEMBLY INTO OUTER CONTACT BODY FIRMLY SEATING FERRULE. CRIMP FERRULE USING PROCRIMPER HANDTOOL #354940-1 AND LOCATOR 91907-2.

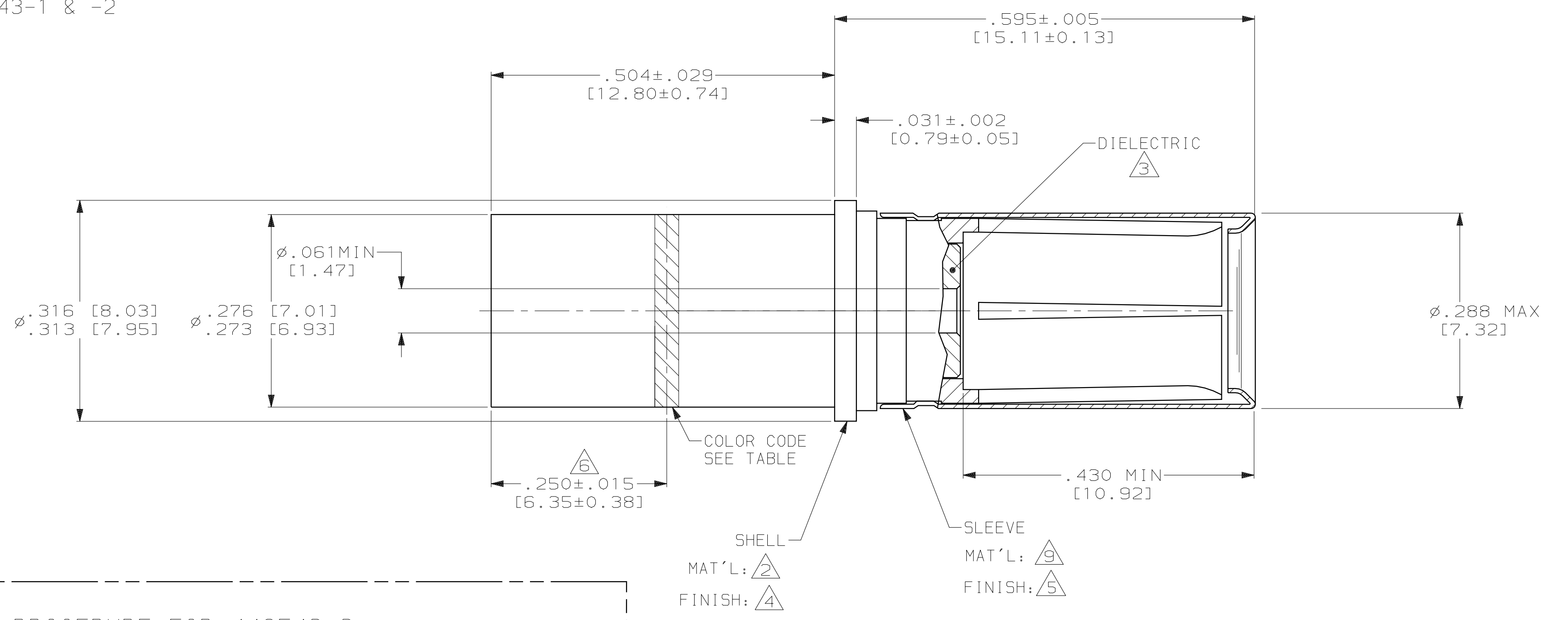

CABLE	FERRULE VIEW	COLOR BAND	A DIM	PART NO.
DMS2345-62AU	SEE DETAIL B	-	.188 [4.78]	448543-3
ADAMS RUSSELL FC14Z	SEE DETAIL A	GREEN	.157 [3.99]	448543-2
ADAMS RUSSELL FC11Z	SEE DETAIL A	RED	.115 [2.92]	448543-1

DO NOT SCALE PRINT. UNLESS SPECIFIED DIMENSIONS IN INCHES [mm] TOLERANCES ON: 2 PLC DEC ± - 3 PLC DEC ± .005 [0.13] ANGLES ± -	DR 10-23-92 C.C.THOMAS CHK 11-2-92 C.SHELLY APPD 11-2-92 C.SHELLY RLSE 11-2-92 C.C.THOMAS	AMP Incorporated Harrisburg, PA 17105-3608		
SEE CALLOUTS	PRODUCT SPEC -	NAME COAX SOCKET CONTACT ASSEMBLY, REAR RELEASE, LONG ENGAGEMENT, SIZE 8 (CARINC-TRIAO)		
FINISH SEE CALLOUTS	APPLICATION SPEC -	SIZE D	CAGE CODE 00779	DRAWING NO 448543
WEIGHT -		SCALE 8:1	SHEET 1 OF 1	