

## M41T62LC6F adapter board for a standard DIL 24 socket

Data brief

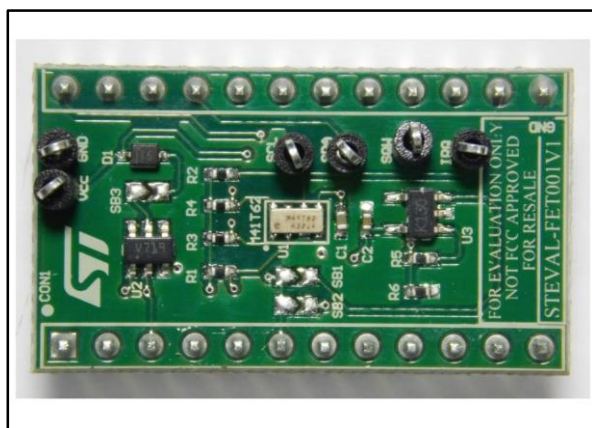

### Features

- Complete M41T62LC6F pinout (I<sup>2</sup>C interface) for a standard DIL 24 socket
- RoHS compliant

### Description

The STEVAL-FET001V1 is an adapter board for the evaluation of the M41T62LC6F low-power serial real-time clock (RTC) with alarm. The board offers an effective solution for fast system prototyping and device evaluation directly inside your application.

The STEVAL-FET001V1 can be plugged into a standard DIL 24 socket.

The adapter provides the complete M41T62LC6F pinout and comes ready-to-use with the required diode and capacitor for stand-by operation when the main supply is absent. The square wave and interrupt pins are also easily accessible thanks to dedicated test points.

# 1 Schematic diagram

Figure 1: STEVAL-FET001V1 circuit schematic

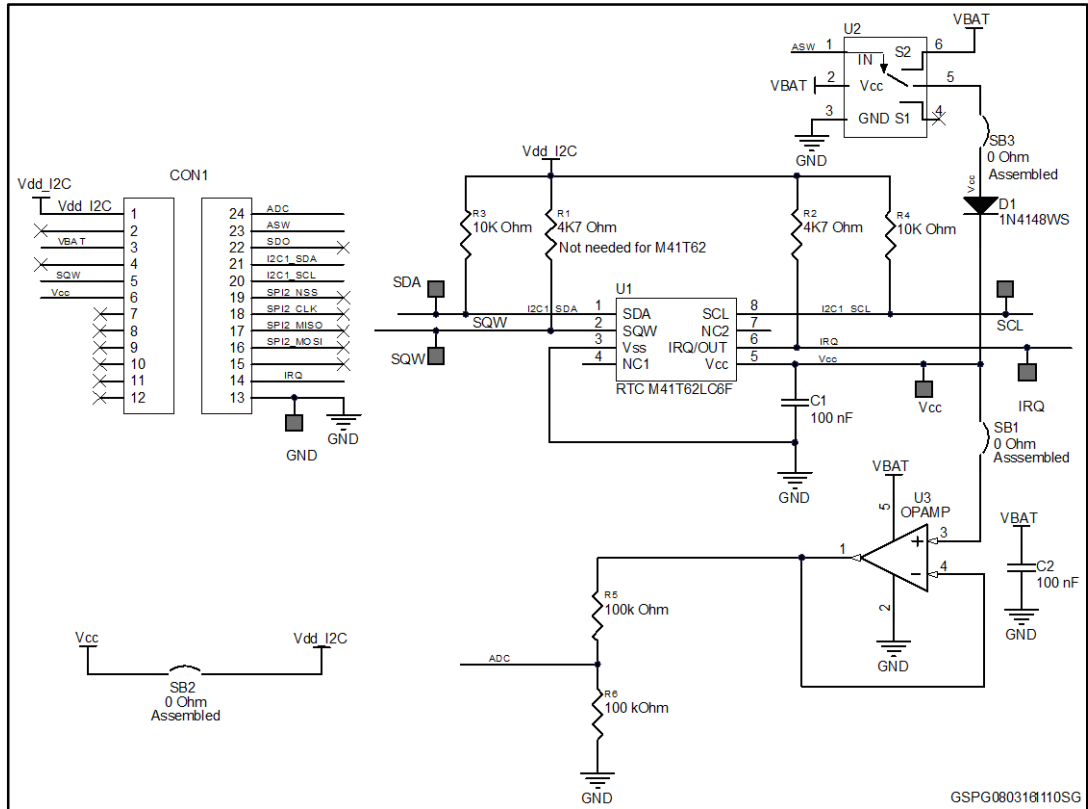

## 2 Revision history

Table 1: Document revision history

Date	Version	Changes
11-Mar-2016	1	Initial release.

**IMPORTANT NOTICE – PLEASE READ CAREFULLY**

STMicroelectronics NV and its subsidiaries ("ST") reserve the right to make changes, corrections, enhancements, modifications, and improvements to ST products and/or to this document at any time without notice. Purchasers should obtain the latest relevant information on ST products before placing orders. ST products are sold pursuant to ST's terms and conditions of sale in place at the time of order acknowledgement.

Purchasers are solely responsible for the choice, selection, and use of ST products and ST assumes no liability for application assistance or the design of Purchasers' products.

No license, express or implied, to any intellectual property right is granted by ST herein.

Resale of ST products with provisions different from the information set forth herein shall void any warranty granted by ST for such product.

ST and the ST logo are trademarks of ST. All other product or service names are the property of their respective owners.

Information in this document supersedes and replaces information previously supplied in any prior versions of this document.

© 2016 STMicroelectronics – All rights reserved