

THIS DRAWING IS UNPUBLISHED. RELEASED FOR PUBLICATION .19  
 © COPYRIGHT 19 BY AMP INCORPORATED. ALL INTERNATIONAL RIGHTS RESERVED.

LOC		DIST		REVISIONS				DATE	APPD
ZONE	LTR			DESCRIPTION					
G	14	P	F	A	REV & REDRAWN PER 0720-0008-93	2-1-93	1 <sup>st</sup> DAP		

**METRIC**  
 DIMENSIONS LISTED IN mm [ INCHES ]

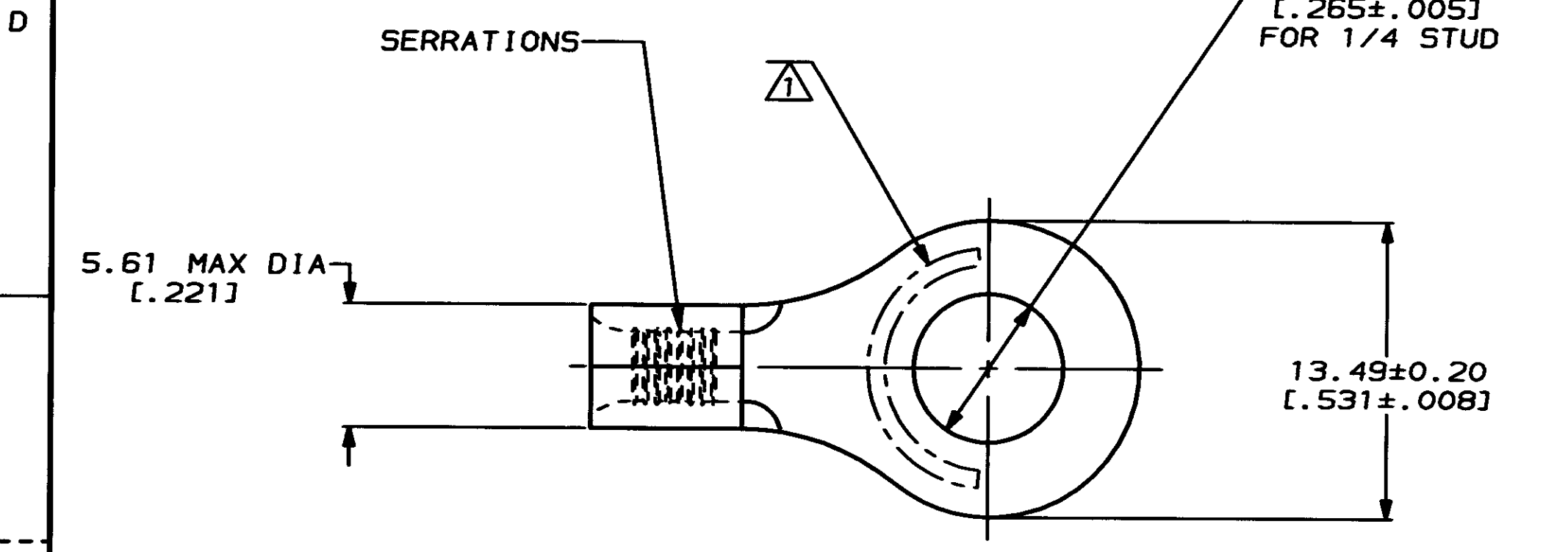

<b>AMP</b> WIRE RANGE	E13288 Listed
16-14HD AWG STRANDED	16-14HD AWG STRANDED
LR7189 Certified	MILITARY P/N AND CLASS
NOT CERTIFIED	NOT APPLICABLE

STAMP AMP 16-14HD\* APPROX AS SHOWN

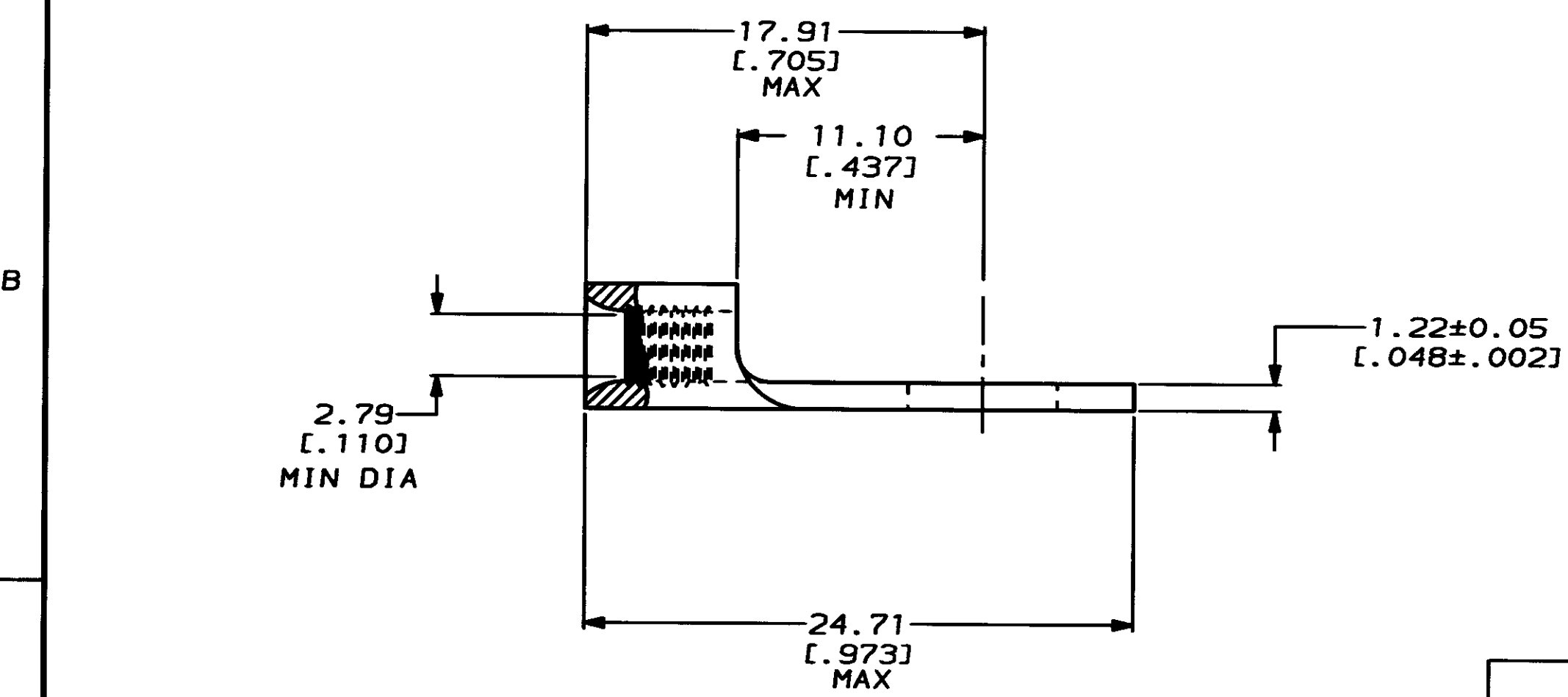

**AMP INCORPORATED**  
**CUSTOMER SERVICE SYSTEMS**

FOR ADDITIONAL PRODUCT INFORMATION OR COPIES OF DRAWINGS AND TECHNICAL DOCUMENTS	PRODUCT INFORMATION CENTER 1-800-522-6752
FOR APPLICATION TOOLING INFORMATION	TOOLING ASSISTANCE CENTER 1-800-722-1111
FOR ORDER ENTRY	1-800-526-5142

MAX RECOMMENDED OPERATING TEMPERATURE:  
 170°C MAX

VOLTAGE RATING:  
 NOT APPLICABLE

WIRE CROSS SECTIONAL AREA RANGE:  
 1.04-2.62mm<sup>2</sup> [2,050-5,180] CIR MILS  
 STRANDED

THIS DRAWING IS A CONTROLLED DOCUMENT FOR AMP INCORPORATED. IT IS SUBJECT TO CHANGE AND THE CONTROLLING ENGINEERING ORGANIZATION SHOULD BE CONTACTED FOR THE LATEST REVISION.

DO NOT SCALE PRINT. UNLESS SPECIFIED DIMENSIONS IN mm [INCHES] TOLERANCES ON:  
 2 PLC DEC ± -  
 3 PLC DEC ± -  
 ANGLES ± -

MATERIAL  
 COPPER PER ASTM B-152 ANNEALED

FINISH  
 TIN PLATE 0.00254 [.000100] MIN THK PER MIL-T-10727

DR 2-1-93 TA BRINKMAN  
 CHK 2-1-93 DA PATTERSON  
 APPD 2-1-93 DE MILLER  
 APPD 2-1-93 JL MECKLEY  
 PRODUCT SPEC -  
 APPLICATION SPEC -  
 WEIGHT -

33195  
 PART NO

**AMP** AMP Incorporated  
 Harrisburg, PA 17105-3608

NAME  
 TERMINAL, RING TONGUE,  
 HEAVY DUTY, BUDGET

SIZE CAGE CODE 00779 DRAWING NO 33195  
 SCALE 4:1 SHEET 1 OF 1