

LTC3577 and LTC3577-1 Highly Integrated 6-Channel Portable PMIC

DESCRIPTION

WARNING!

Do not look directly at operating LED.

This circuit produces light that can damage eyes.

Demo Circuit 1402 is a Highly Integrated 6-Channel Portable PMIC with a push button controller, two LDOs, three buck converters, a Li-Ion battery charger, a Power-Path controller, and high voltage buck controller interface featuring the LTC3577 and LTC3577-1.

The LTC3577 is a PowerPath™ manager with automatic load prioritization, battery charger, Bat-Track™ controller, push button controlled power up sequence and reset, and a 10 LED string controller with gradation and PWM control. The three buck regulators and the LED Boost controller have adjustable slew rates for EMI reduction.

The LTC3577 has a high temperature battery voltage reduction feature that reduces the battery voltage under high temperature conditions to improve safety and reliability.

The high voltage (HV) buck interface is designed to connect to and control an external HV buck regulator demo board via the Bat-Track control circuitry. Some of these demo boards are the DC1394A, DC1395A, and DC1325A, featuring the LT3480, LT3505, and the LT3563 HV bucks respectively.

Refer to the LTC3577 datasheet for more details on the electrical and timing specifications.

Design files for this circuit board are available. Call the LTC factory.

LT, LTC, LTM, LT are registered trademarks of Linear Technology Corporation. PowerPath and Bat-Track are trademarks of Linear Technology Corporation. All other trademarks are the property of their respective owners.

PERFORMANCE SUMMARY Specifications are at T_A = 25°C

PARAMETER	CONDITIONS	MIN	TYP	MAX	UNITS
Input Supply Range (V _{BUS})	NOTE: The input current limit is reduced when V _{BUS} falls below 4.45V (TYP).	4.35		5.5	V
Absolute Wall Input Threshold (V _W)	V _{WALL} Rising V _{WALL} Falling	3.1	4.3 3.2	4.45	V
DV _{CC} Operating Voltage		1.6		5.5	V
DV _{CC} UVLO (V _{DVCC,UVLO})			1		V
V _{BAT} Regulated Output Voltage (V _{FLOAT})	LTC3577 LTC3577-1	4.179 4.079	4.200 4.100	4.221 4.121	V
Constant Current Mode Charge Current (I _{CHRG})	R _{PROG} = 2KΩ, Input current limit = 1A	465	500	535	mA
V _{OUT} UVLO	V _{OUT} Falling V _{OUT} Rising	2.5	2.7 2.8	2.9	V
V _{OUT1}	0 to 500mA		3.3		V
V _{OUT2}	0 to 500mA		1.8		V
V _{OUT3}	0 to 800mA		1.2		V
LDO1	0 to 150mA		1.5		V
LDO2	0 to 150mA		2.5		V
Full-Scale LED Current			20		mA

QUICK START PROCEDURE

Demo Circuit 1402 is designed to be used with a USB input and/or an external HV buck demo board, such as the DC1325A, DC1394A, or DC1395A featuring the LT3653, LT3480 and the LT3505 respectively. Demo Circuit 1402 utilizes the DC590B, USB to I²C interface board, to control the LED boost driver, LDO enables, and buck modes. It is also used to monitor the buck and LDO outputs, plus battery charger status. This circuit may be evaluated using a lithium ion battery or a battery simulator consisting of a 0V-5V, 3A power supply and a 3.6Ω power resistor.

The DC1402 is easy to set up to evaluate the performance of the LTC3577 and LTC3577-1. Refer to Figure 1 and Figure 2 for proper measurement equipment setup and follow the procedure below to evaluate using the DC590B board:

NOTE. When measuring the input or output voltage ripple, care must be taken to avoid a long ground lead on the oscilloscope probe. Measure the input or output voltage ripple by touching the probe tip directly across the Vin or Vout and GND terminals. See Figure 2 for proper scope probe technique.

1. Refer to the DC590B Quick Start Guide for QuikEval™ setup and software installation details.
2. Set the VCCIO jumper, JP6, on the DC590B board to the 3.3V position.
NOTE. The DVCC voltage level may be selected on the DC590B. This is done by setting the VCCIO jumper, JP6, on the DC590B board to one of the following settings: 3.3V, 5V, removed for 2.7V or set to external if an external supply is desired to be used.
3. Make sure the USB cable is connected between the computer and the DC590B controller board.
4. Set the jumpers on the DC1402-2 board to the following settings:
 - JP1. PWR_ON CNTL to “SW” position.
 - JP2. ILIM1 to “1” position.
 - JP3. ILIM0 to “1” position.
 - JP4. STATUS PIN PULL-UP to “VOUT” position.
 - JP5. NTC to “INT” position.
 - JP6. VINLDO2 to “VOUT” position.
 - JP7. VINLDO1 to “VOUT” position.

5. Connect DC1402 to the DC590B USB Serial Controller using the supplied 14-conductor ribbon cable as shown in Figure 1.
6. With power off, connect a 5V, 1A power supply to VUSB and GND with a series ammeter and a voltmeter as shown in Figure 1.
7. Connect a battery or a battery simulator set to 3.6V between BAT and GND with a series ammeter and a voltmeter as shown in Figure 1.
8. Turn on and set the VUSB input power supply to 5V. The DC590B board gets its power from the USB cable.
NOTE. Make sure that the input voltage does not exceed 6V.
9. Run the QuikEval.exe program. The LTC3577 control window (shown in Figure 3) pops up.
NOTE. The Status indicators on the software control window may display “N/A” when an I²C ACK was not received. This occurs when the part is in the power down (PDN) state or when DVCC is missing. Please refer to the LTC3577 datasheet for more information on the PDN state.
10. On the LTC3577 control window, select the PWR_ON HI/LOW button. When “HI” is indicated on the button, the PWR_ON pin goes high and the VOUT1, VOUT2, and VOUT3 outputs sequence up. VOUT POWER GOOD for each output is indicated on the STATUS section on the control window.
11. Select the BUCK1 through BUCK3 MODE buttons to switch the bucks into Burst mode. Observe the output ripple and the quiescent current before and after switching modes.
12. Select the desired BUCK SW SLEW RATE option button to switch between a fast rise-time for best efficiency to a slower rise time with better EMI performance.
13. Select the LDO1 and LDO2 EN/DIS buttons to enable LDO1 and LDO2 via the I²C bus.
14. Set the LED DAC REG vertical slider to a desired current level. The LED current and the LED DAC register setting are displayed in the test boxes below the vertical slider. The LED full scale current (I_{LED(FS)}) for this circuit is 20mA.

$$I_{LED} = I_{LED(FS)} \cdot 10^{\left(3 \cdot \frac{DAC - 63}{63}\right)}$$

$$I_{LED(FS)} = \frac{0.8V}{R18} \cdot 500$$

15. Select the LED EN/DIS button to turn on the LEDs. Select the button again to turn off the LEDs.
16. Select the “460ms” GRADATION TIME option button then select the LED EN/DIS button. Observe how the LEDs turn on and off smoothly when the LED boost circuit is enabled and disabled.
17. Select the “PWM” LED MODE option button. This allows the LED intensity to be adjusted with the PWM controls as well as the DAC register.
18. Set the “PWM Numerator” and the “PWM Denominator” vertical sliders to their maximum position. The hexadecimal value of “F” is displayed in the setting text boxes below the sliders. The PWM duty cycle and frequency are also displayed below the setting text boxes.

$$Duty\ Cycle = \frac{PWMNUM}{PWMDEN}$$

$$Frequency = \frac{PWMCLK}{PWMDEN}$$

19. With the LED boost enabled, reduce the “PWM Numerator” vertical slider while observing the LED intensity. Notice that the LEDs dim as the numerator is decreased.
20. Select a different “PWM Clock Speed” option button and observe the PWM frequency changes accordingly.
21. If using an external HV buck demo board, connect it to demo circuit 1402-2 as indicated in Figure 1.
22. Refer to the appropriate HV buck Quick Start Guide to set the HV buck demo board jumpers to the appropriate settings. If using the DC1325A, LT3653EDCB HV buck demo board, set the “WALL” jumper, JP1, to the “HV BUCK” position. Then set jumpers JP2 and JP3 to the “1” position to obtain a 1.2A current setting.

23. With power off, connect a power supply to the input of the HV buck circuit. Turn on the power supply and set the voltage within the HV buck input operating range.

NOTE. If HV BUCK demo board has a \overline{SHDN} feature such as the DC1394, LT3480 demo board, select the “HV/SHDN HI/LOW” button on the LTC3577 Control Window to put the HV BUCK into and out of shutdown.

24. Observe that the input current is now coming from the HV buck input instead of the VUSB input and VOUT is about VBAT plus 0.3V.
25. Increase VBAT to 4.0V and observe how VOUT and the HV BUCK output tracks the battery voltage.
26. Refer to the “USING THE LTC3577 SOFTWARE” section for more information on how to control the device using the LTC3577 control window.
27. Set the “PWR_ON CNTL” jumper, JP1, to the “PB” position to power up/down the device with the “ \overline{ON} ” pushbutton, PB1.
28. Depress the “ \overline{ON} ” pushbutton, PB1 (minimum of 400ms). VOUT1, VOUT2, and VOUT3 outputs sequence up. VOUT POWER GOOD for each output is indicated on the STATUS section on the control window.
29. Wait at least five seconds from depressing PB1, then depress the “PWR_ON” pushbutton, PB2. VOUT1, VOUT2, and VOUT3 outputs shutdown.
30. Again depress PB1, the “ \overline{ON} ” pushbutton. VOUT1, VOUT2, and VOUT3 outputs sequence up.
31. Wait at least five seconds from depressing PB1, and then depress and hold PB1 for at least 5 seconds. The device enters the power down (PDN) state, VOUT1, VOUT2, and VOUT3 outputs shut down and the software control window STATUS indicators display “N/A”.
32. To return from the PDN state, depress PB1 again or change JP1 to the “SW” position and set the “PWR_ON HI/LOW” button on the software control window to “HI”.
33. The input current limit may be adjusted by changing the “ILIMO” and “ILIM1” jumpers, JP3 and JP2 respectively. See Table 1 for details.

Table 1. Input Current Limit Settings

ILIM1	ILIM0	CURRENT LIMIT
0	0	100mA (1X)
0	1	1A (10X)
1	0	0.5mA (SUSP)
1	1	500mA (5X)

34. Refer to the LTC3577 datasheet for more details on how the LTC3577 operates.
35. When done, turn off all loads and power supplies, then close the LTC3577 control window.

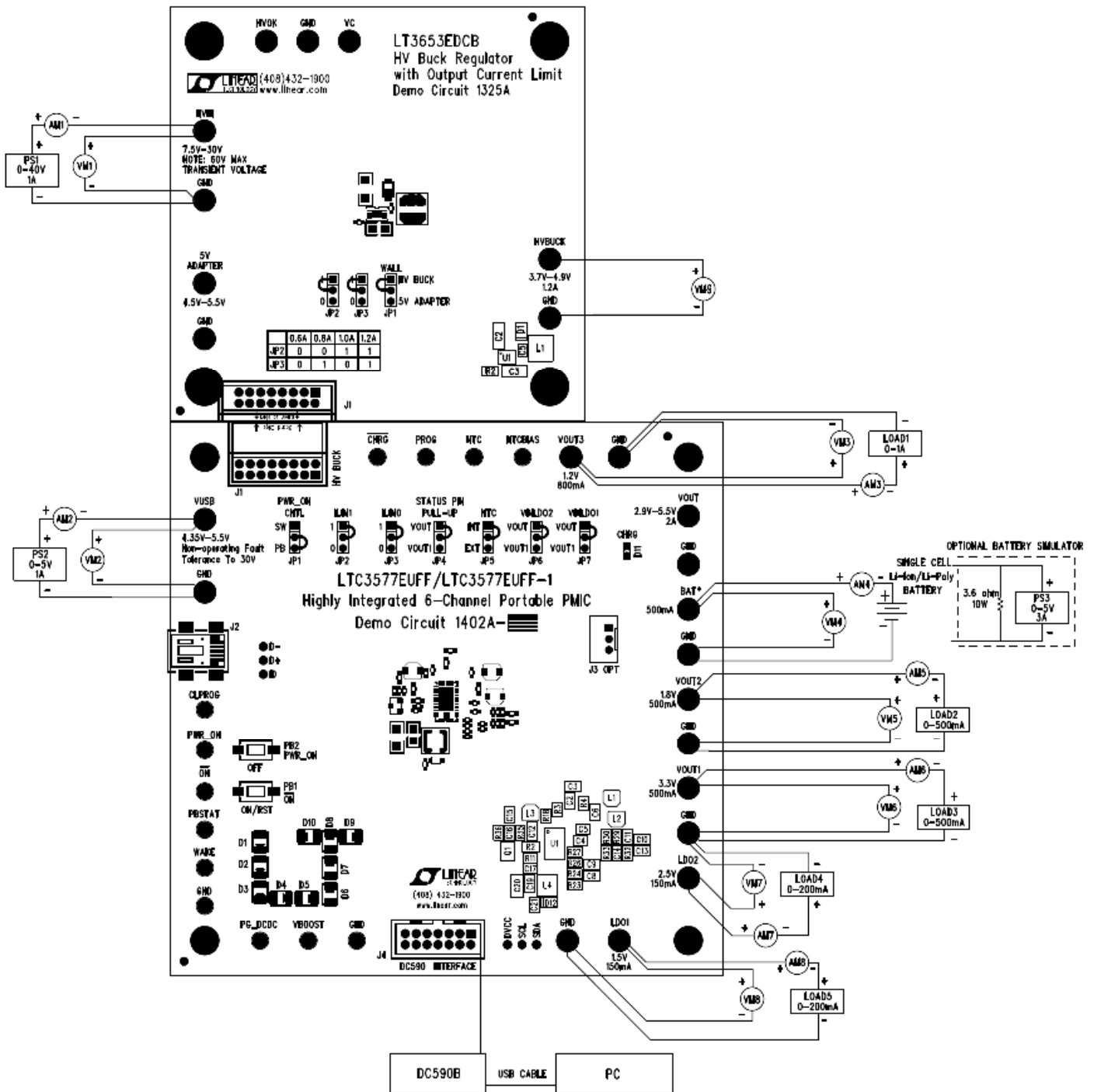

Figure 1. Proper Measurement Equipment Setup

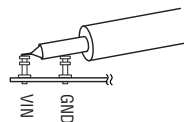

Figure 2. Measuring Input or Output Ripple

USING THE LTC3577 SOFTWARE

The LTC3577 program provides control of the mode and slew rate of the buck regulators, plus controls the intensity and slew rate of the LED boost controller. It also allows the user to view the contents of the status register. Refer to Figure 3 for an illustration of the LTC3577 control window.

VIEW LTC3577 PRODUCT PAGE button opens an internet browser and searches the Linear Technology Corporation web site for information on the LTC3577 when an internet connection is available.

REG0 through **REG3** text box windows display the hexadecimal value that has been written to the corresponding registers.

STATUS REG text box window displays the hexadecimal value that has been last read from the LTC3577 status register.

LDO1 and **LDO2 EN/DIS** buttons enable or disable LDO1 and LDO2 respectively via the I²C interface.

BUCK1 through **BUCK3 MODE** select buttons are used to individually set each buck regulator into Pulse Skip Mode for low noise or Burst Mode for high efficiency.

BUCK SW SLEW RATE option buttons are used to choose one of four slew rates for optimal EMI reduction or efficiency. Choose “1ns” for optimal efficiency.

HV/SHDN HI/LOW select button is used to turn on or shutdown the high voltage buck demo board with the shutdown feature.

PWR_ON HI/LOW select button is used to set the PWR_ON pin high or low to turn on or off VOUT1, VOUT2, and VOUT3.

AUTO READ BACK EN/DIS select button is used to automatically update the status register every 250ms when enabled. When disabled the read register may be updated by selecting the “Read Back Status” button.

Read Back Status button is used to update the status register when selected.

AUTO UPDATE EN/DIS select button is used to automatically update the LTC3577 I²C registers when any of the buck or LED buttons or sliders have been changed.

When auto update is disabled, the LTC3577 I²C registers may be updated by selecting the “Update All Registers” button.

Update All Registers button is used to update all of the LTC3577 I²C write registers when selected.

NOTE: When power is turned off or removed, the I²C registers are reset and the LTC3577 control window will not match the actual condition of the evaluation board. Use the “Update All Registers” button to set the device to the current settings selected on the LTC3577 control window.

LED EN/DIS select button is used to enable or disable the LED boost controller.

BOOST SW SLEW RATE FAST/SLOW button is used to turn on and off the LED switch faster or slower for optimal efficiency or EMI reduction. Choose “FAST” for optimal efficiency.

LED MODE option buttons are used to choose one of three Boost controller modes. CC Boost mode is a constant current mode where the LED current is controlled by the LED DAC REG vertical slider. HV Boost mode regulates the ILED pin to 0.8V to operate the Boost at a fixed voltage. **HV Boost mode should not be enabled unless the demo circuit has been modified to support this mode of operation.** PWM mode allows the LED intensity to be controlled by pulse width modulating the LEDs based on the LED DAC REG, PWM Numerator, PWM Denominator, and PWM Clock Speed settings.

NOTE: When in CC Boost or HV Boost LED modes, the PWM controls are disabled.

GRADATION TIME option buttons set the desired time to graduate up to or down from the selected intensity whenever the LED controller is enabled or disabled.

LED DAC REG vertical slider controls the LED current from 20uA to 20mA in 64 logarithmic steps. The intensity slider may be adjusted by clicking on the up or down arrows to increment or decrement by one LSB or by clicking and dragging the slide pointer. The hex code and LED current are displayed in the two text boxes below the slider.

PWM Clock Speed option buttons are used to select the PWM clock speed. The PWM clock speed is divided by the PWM denominator to determine the PWM frequency.

This can only be changed when the “PWM” “LED MODE” option button is selected.

PWM Numerator vertical slider is used to select a PWM numerator value. The PWM numerator is divided by the PWM denominator to determine the PWM duty cycle. This can only be changed when the “PWM” “LED MODE” option button is selected.

PWM Denominator vertical slider is used to select a PWM denominator value. The PWM denominator is used

in conjunction with the PWM numerator to determine the PWM duty cycle and with the PWM clock speed to determine the PWM frequency. This can only be changed when the “PWM” “LED MODE” option button is selected.

STATUS indicators display the charge, NTC, and power status determined by the LTC3577 status register. If an acknowledge was not received, the status indicators will display “N/A”. This may occur when DVCC is missing or during the PDN state.

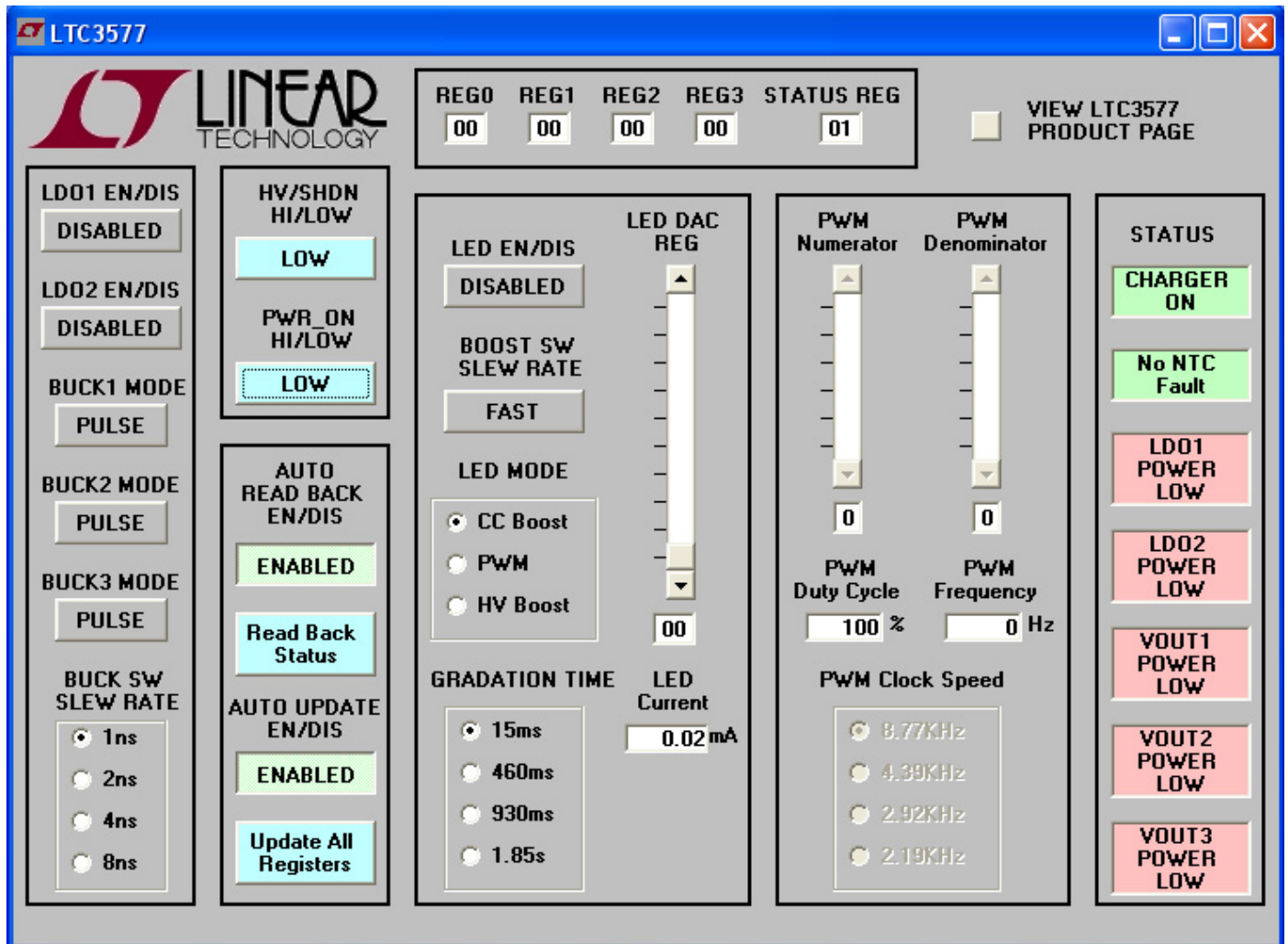
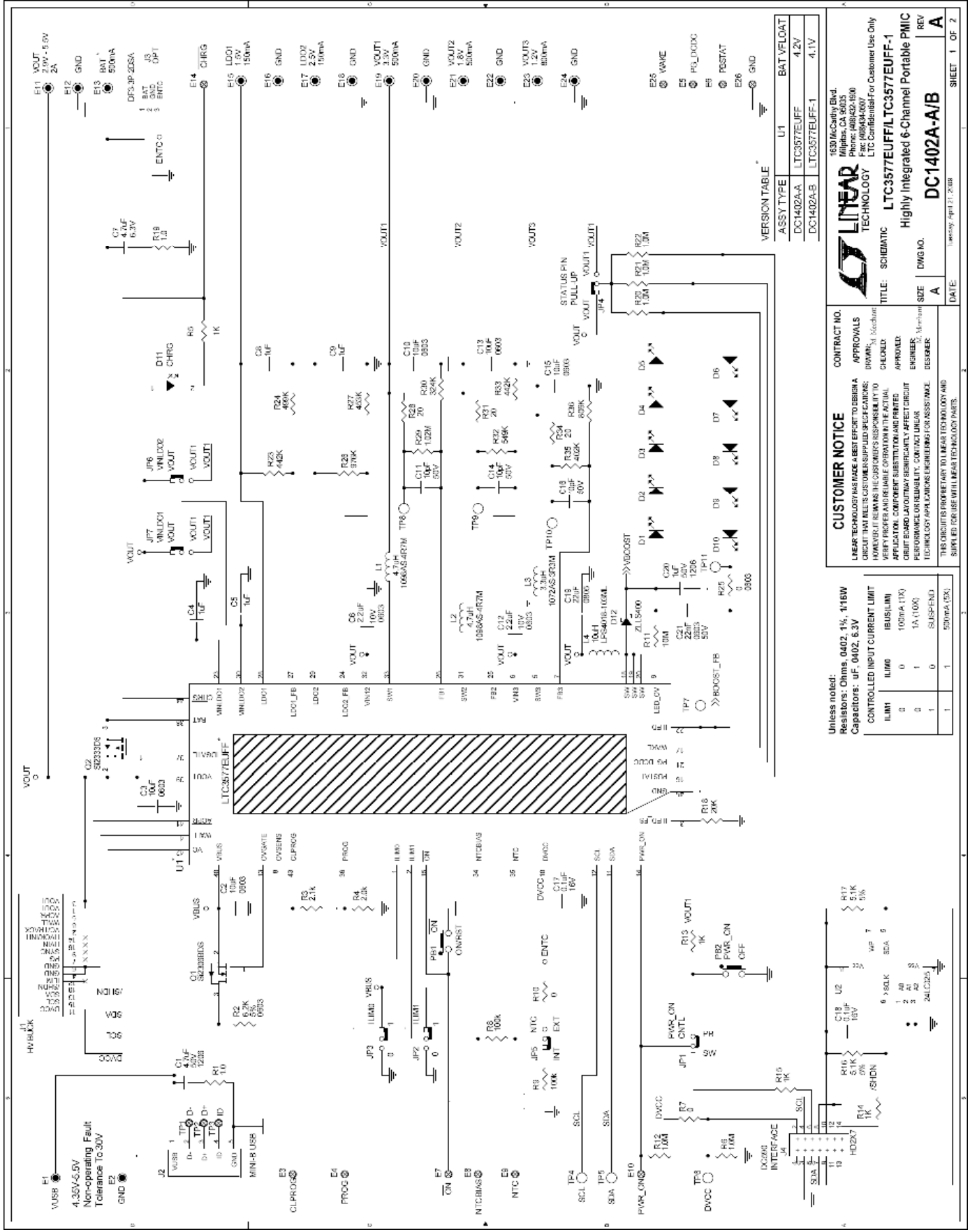

Figure 3. LTC3577 Control Window

LTC3577 AND LTC3577-1



Unless noted:
Resistors: Ohms, 0402, 1%, 1116W
Capacitors: μ F, 0402, 6.3V

CONTROLLED INPUT CURRENT LIMIT	
LIMIT	ILIMIT
0	IBUSILIM
0	1000A (IX)
0	1A (IOX)
1	0
1	SUSPEND
1	500mA (IO)

CUSTOMER NOTICE
LINEAR TECHNOLOGY MAKES NO REPRESENTATION OR WARRANTY AS TO THE SUITABILITY OF THIS PRODUCT FOR ANY PARTICULAR APPLICATION. CUSTOMERS ARE RESPONSIBLE FOR VERIFYING PROPER AND RELIABLE OPERATION IN THEIR APPLICATION. COMPONENT SUBSTITUTION AND PRINTED CIRCUIT BOARD LAYOUT MAY SIGNIFICANTLY AFFECT CIRCUIT PERFORMANCE OR RELIABILITY. CONTACT LINEAR TECHNOLOGY APPLICATIONS ENGINEERING FOR ASSISTANCE. DESIGNER.

APPROVALS
DRAWN BY: [Signature]
CHECKED: [Signature]
APPROVED: [Signature]

ENGINEER: [Signature]
DESIGNER: [Signature]

CONTRACT NO.
APPROVALS
DESIGNER
DATE

LINEAR TECHNOLOGY
1635 McCarthy Blvd.
Folsom, CA 95630
Phone: (916) 351-2000
Fax: (916) 351-2001
LTC Confidential For Customer Use Only

TITLE: SCHEMATIC
Highly Integrated 6-Channel Portable PMIC
LTC3577EUFF/LTC3577EUFF-1

DWG NO. DC1402A-A/B
REV A
DATE 10/20/04
SHEET 1 OF 2

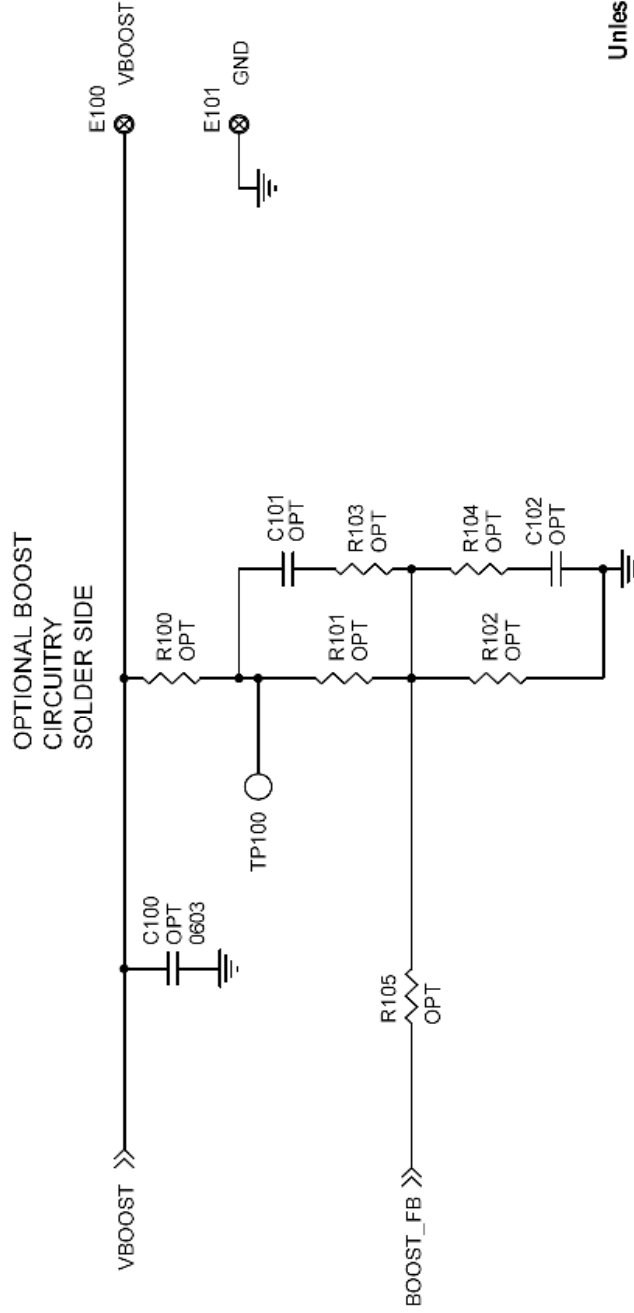

Unless noted:

Resistors: Ohms, 0402, 1%, 1/16W

Capacitors: uF, 0402, 6.3V

1630 McCarthy Blvd.
 Milpitas, CA 95035
 Phone: (408)432-1900
 Fax: (408)434-0507
 LTC Confidential-For Customer Use Only



TITLE: SCHEMATIC	
LTC3577EUFF/LTC3577EUFF-1	
Highly Integrated 6-Channel Portable PMIC	
SIZE	REV
A	A
DWG NO.	DC1402A-A/B
DATE:	SHEET 2 OF 2
Tuesday, April 21, 2009	

CONTRACT NO.	
APPROVALS	
DRAWN: M. Merchant	
CHECKED:	
APPROVED:	
ENGINEER: M. Merchant	
DESIGNER:	
<p>CUSTOMER NOTICE</p> <p>LINEAR TECHNOLOGY HAS MADE A BEST EFFORT TO DESIGN A CIRCUIT THAT MEETS CUSTOMER-SUPPLIED SPECIFICATIONS; HOWEVER, IT REMAINS THE CUSTOMER'S RESPONSIBILITY TO VERIFY PROPER AND RELIABLE OPERATION IN THE ACTUAL APPLICATION. COMPONENT SUBSTITUTION AND PRINTED CIRCUIT BOARD LAYOUT MAY SIGNIFICANTLY AFFECT CIRCUIT PERFORMANCE OR RELIABILITY. CONTACT LINEAR TECHNOLOGY APPLICATIONS ENGINEERING FOR ASSISTANCE.</p> <p>THIS CIRCUIT IS PROPRIETARY TO LINEAR TECHNOLOGY AND SUPPLIED FOR USE WITH LINEAR TECHNOLOGY PARTS.</p>	

LTC3577 AND LTC3577-1

Linear Technology Corp.
LTC3577EUFF/LTC3577EUF-1

Parts List

Bill Of Material
Demo Circuit: 1402A-A/B, Sch. Rev -A
5/6/2009

Item	Qty	Reference - Des	Part Description	Manufacturer, Part #
REQUIRED CIRCUIT COMPONENTS:				
1	1	C1	CAP, CHIP, X7R, 4.7µF, ±10%, 50V, 1206	MURATA, GRM31CR71H475KA12L
2	5	C2,C3,C10,C13,C15	CAP, CHIP, X5R, 10µF, ±20%, 6.3V, 0603	TDK, C1608X5R0J106M
3	4	C4,C5,C8,C9	CAP, CHIP, X5R, 1µF, ±10%, 6.3V, 0402	MURATA, GRM155R60J105KE15D
4	2	C6,C12	CAP, CHIP, X5R, 2.2µF, ±10%, 10V, 0603	MURATA, GRM188R61A225KE34D
5	3	C11,C14,C16	CAP, CHIP, NPO, 10pF, ±5%, 50V, 0402	AVX, 04025A100JAT
6	1	C17	CAP, CHIP, X7R, 0.1µF, ±10%, 16V, 0402	MURATA, GRM155R71C104KA88
7	1	C19	CAP, CHIP, X5R, 22µF, ±20%, 6.3V, 0805	TAIYO YUDEN, JMK212BJ226MG
8	1	C20	CAP, CHIP, X7R, 1µF, ±10%, 50V, 1206	MURATA, GRM31MR71H105KA88L
9	1	C21	CAP, CHIP, X7R, 22nF, ±10%, 50V, 0603	MURATA, GRM188R71H223KA01
10	10	D1-D10	DIODE, LED, WHITE, SMT, 1206	NICHIA, NSSW100BT
11	1	D12	DIODE, SCHOTTKY, 40V, 1A, SOD-323	ZETEX, ZLLS400
12	2	L1,L2	IND, SMT, 4.7µH, 90mΩ, ±20%, 1A, 3.2mmX2.5mm	TOKO, 1098AS-4R7M
13	1	L3	IND, SMT, 3.3µH, 53mΩ, ±20%, 1.1A, 3.6mmX3.0mm	TOKO, 1072AS-3R3M
14	1	L4	IND, SMT, 10µH, 200mΩ, ±20%, 1.1A, 4.4mmX4.4mm	COILCRAFT, LPS4018-103ML
15	1	Q1	MOSFET, 30V, 65mΩ, 3.5A, SOT-23	VISHAY, Si2306BDS-T1-E3
16	1	Q2	MOSFET, -12V, 35mΩ, -5.3A, SOT-23	VISHAY, Si2333DS
17	1	R2	RES, CHIP, 6.2KΩ, ±5%, 1/10W, 0603	VISHAY, CRCW06036K20JNED
18	1	R3	RES, CHIP, 2.1KΩ, ±1%, 1/16W, 0402	VISHAY, CRCW04022K10FKED
19	1	R4	RES, CHIP, 2.00KΩ, ±1%, 1/16W, 0402	VISHAY, CRCW04022K00FKED
20	1	R11	RES, CHIP, 10MΩ, ±1%, 1/16W, 0402	VISHAY, CRCW040210M0FKED
21	1	R18	RES, CHIP, 20KΩ, ±1%, 1/16W, 0402	VISHAY, CRCW040220K0FKED
22	2	R23,R33	RES, CHIP, 442KΩ, ±1%, 1/16W, 0402	VISHAY, CRCW0402442KFKED
23	1	R24	RES, CHIP, 499KΩ, ±1%, 1/16W, 0402	VISHAY, CRCW0402499KFKED
24	1	R26	RES, CHIP, 976KΩ, ±1%, 1/16W, 0402	VISHAY, CRCW0402976KFKED
25	1	R27	RES, CHIP, 453KΩ, ±1%, 1/16W, 0402	VISHAY, CRCW0402453KFKED
26	1	R29	RES, CHIP, 1.02MΩ, ±1%, 1/16W, 0402	VISHAY, CRCW04021M02FKED
27	1	R30	RES, CHIP, 324KΩ, ±1%, 1/16W, 0402	VISHAY, CRCW0402324KFKED
28	1	R32	RES, CHIP, 549KΩ, ±1%, 1/16W, 0402	VISHAY, CRCW0402549KFKED
29	1	R35	RES, CHIP, 402KΩ, ±1%, 1/16W, 0402	VISHAY, CRCW0402402KFKED
30	1	R36	RES, CHIP, 806KΩ, ±1%, 1/16W, 0402	VISHAY, CRCW0402806KFKED
31	1	U1 (DC1402-2-A)	Highly Integrated Portable Automotive PMIC 4.2V VFLOAT	LINEAR TECH., LTC3577EUFF
	1	U1 (DC1402-2-B)	Highly Integrated Portable Automotive PMIC 4.1V VFLOAT	LINEAR TECH., LTC3577EUFF-1
ADDITIONAL DEMO BOARD CIRCUIT COMPONENTS				
1	1	C7	CAP, CHIP, X5R, 4.7µF, +/-10% 6.3V, 0603	TDK, C1608X5R0J475K
2	1	C18	CAP, CHIP, X7R, 0.1µF, ±10%, 16V, 0402	MURATA, GRM155R71C104KA88
3	0	C100 (OPT)	CAP, CHIP, 0603	
4	0	C101,C102 (OPT)	CAP, CHIP, 0402	
5	1	D11	DIODE, LED, GREEN, SMT, 0603	PANASONIC, LNJ336W83RA
6	2	R1,R19	RES, CHIP, 1.0Ω, ±1%, 1/16W, 0402	VISHAY, CRCW04021R00FKED
7	4	R5,R13,R14,R15	RES, CHIP, 1KΩ, ±1%, 1/16W, 0402	VISHAY, CRCW04021K00FKED
8	5	R6,R12,R20,R21,R22	RES, CHIP, 1.0MΩ, ±1%, 1/16W, 0402	VISHAY, CRCW04021M00FKED
9	2	R7,R10	RES, CHIP, 0Ω jumper, 1/16W, 0402	VISHAY, CRCW04020000Z0ED
10	2	R8,R9	RES, CHIP, 100kΩ, ±1%, 1/16W, 0402	VISHAY, CRCW0402100KFKED
11	2	R16,R17	RES, CHIP, 5.1kΩ, ±5%, 1/16W, 0402	VISHAY, CRCW04025K10JNED
12	1	R25	RES, CHIP, 0Ω jumper, 1/16W, 0603	VISHAY, CRCW060320000Z0ED
13	3	R28,R31,R34	RES, CHIP, 20Ω, ±1%, 1/16W, 0402	VISHAY, CRCW040220R0FKED
14	0	R100-R105 (OPT)	RES, CHIP, 0402	
15	1	U2	I2C EEPROM	MICROCHIP, 24LC025-I/ST
HARDWARE FOR DEMO BOARD ONLY:				
1	1	J1	SOCKET, HV interface, 2x8 PIN	SAMTEC, SQT-108-01-F-D-RA
2	1	J2	CONN, USB Mini-B	TYCO, 1734035-2
3	0	J3 (OPT)	CONN, Battery	HIROSE, DF3-3P-2DSA
4	1	J4	CONN, I2C HEADER	MOLEX, 87831-1420
5	7	JP1-JP7	3 Pin Jumper, 2mm	SAMTEC, TMM-103-02-L-S
6	7	JP1-JP7	SHUNT, 2mm	SAMTEC, 2SN-KB-G
7	2	PB1,PB2	SWITCH, PUSH BUTTON, SMT	PANASONIC, EVQPPFA25
8	15	E1,E2,E11-E13,E15-E24	TURRET, 0.09 DIA	MILL-MAX, 2501-2-00-80-00-00-07-0
9	13	E3-E10,E14,E25,E26,E100,E101	TURRET, 0.061 DIA	MILL-MAX, 2308-2-00-80-00-00-07-0
10	4	MH1-MH4	STAND-OFF, NYLON 0.375" tall (SNAP ON)	KEYSTONE, 8832 (SNAP ON)