

6A Single High-Speed, CMOS Power MOSFET Driver

Features

- High Peak Output Current: 6A
- Wide Input Supply Voltage Operating Range:
 - 7V to 18V
- High-Impedance CMOS Logic Input
- Logic Input Threshold Independent of Supply Voltage
- Low Supply Current:
 - With Logic '1' Input – 5 mA max.
 - With Logic '0' Input – 0.5 mA max.
- Output Voltage Swing Within 25 mV of Ground or V_{DD}
- Short Delay Time: 75 nsec max
- Available in the Space-Saving 8-Pin SOIC Package.
- High Capacitive Load Drive Capability:
 - $t_{RISE}, t_{FALL} = 35$ nsec max with $C_{LOAD} = 2500$ pF

Applications

- Switch-Mode Power Supplies
- CCD Drivers
- Pulse Transformer Drive
- Class D Switching Amplifiers

Package Types

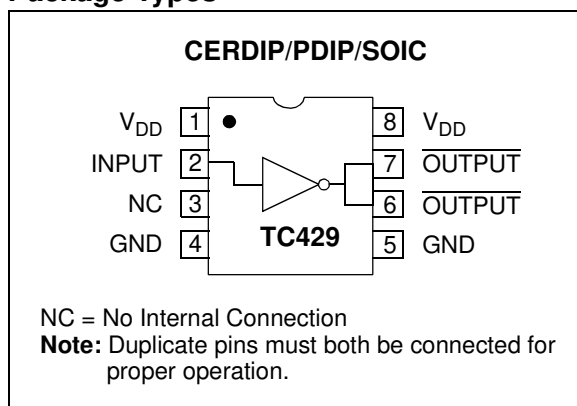

General Description

The TC429 is a high-speed, single output, CMOS-level translator and driver. Designed specifically to drive highly capacitive power MOSFET gates, the TC429 features a 2.5Ω output impedance and 6A peak output current drive.

A 2500 pF capacitive load will be driven to 18V in 25 nsec. The rapid switching times with large capacitive loads minimize MOSFET switching power losses.

A TTL/CMOS input logic level is translated into an output voltage swing that equals the supply voltage and will swing to within 25 mV of ground or V_{DD} . Input voltage swing may equal the supply voltage. Logic input current is under 10 μ A, making direct interface to CMOS/bipolar switch-mode power supply controllers easy. Input "speed-up" capacitors are not required.

The CMOS design minimizes quiescent power supply current. With a logic '1' input, power supply current is 5 mA maximum and decreases to 0.5 mA for logic '0' inputs.

For dual output MOSFET drivers, see the TC426/TC427/TC428 (DS21415), TC4426/TC4427/TC4428 (DS21422) and TC4426A/TC4427A/TC4428A (DS21423) data sheets.

For non-inverting applications, or applications requiring latch-up protection, see the TC4420/TC4429 (DS21419) data sheet.

TC429

Functional Block Diagram

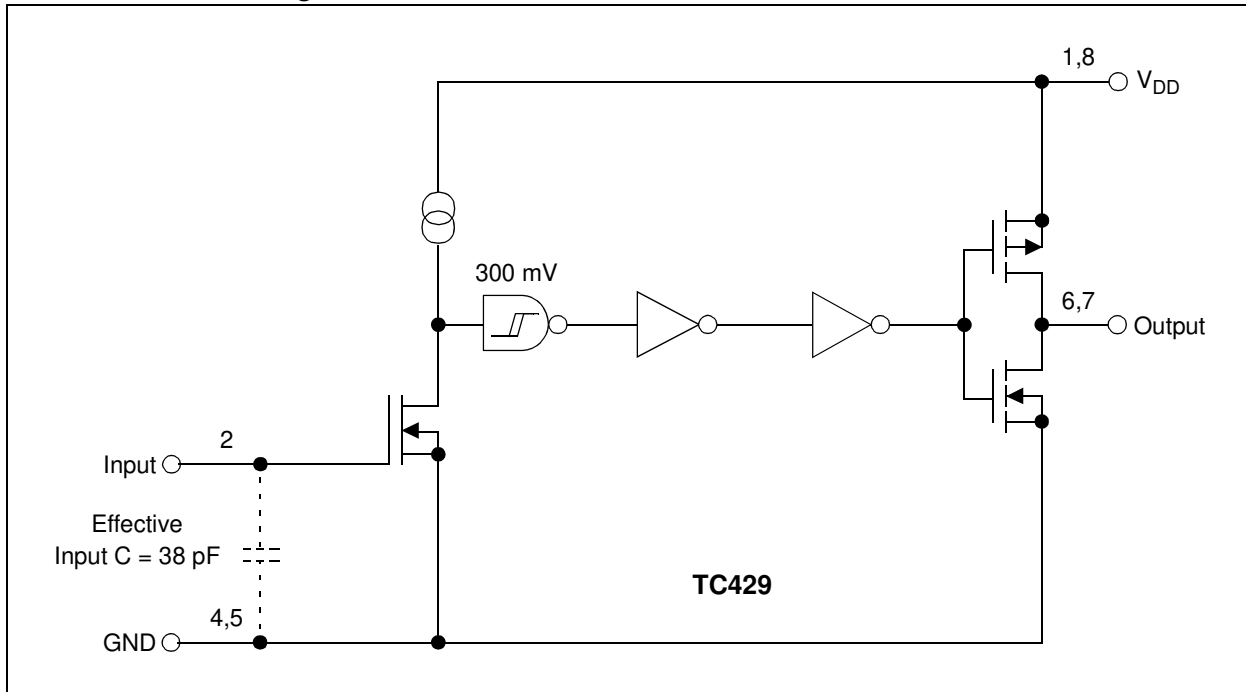

1.0 ELECTRICAL CHARACTERISTICS

Absolute Maximum Ratings †

Supply Voltage	+20V
Input Voltage, Any Terminal	$V_{DD} + 0.3V$ to $GND - 0.3V$
Power Dissipation ($T_A \leq 70^\circ C$)	
PDIP	730 mW
CERDIP	800 mW
SOIC	470 mW
Storage Temperature Range	$-65^\circ C$ to $+150^\circ C$
Maximum Junction Temperature, T_J	$+150^\circ C$

† Stresses above those listed under "Absolute Maximum Ratings" may cause permanent damage to the device. These are stress ratings only and functional operation of the device at these or any other conditions above those indicated in the operation sections of the specifications is not implied. Exposure to Absolute Maximum Rating conditions for extended periods may affect device reliability.

PIN FUNCTION TABLE

Symbol	Description
V_{DD}	Supply input, 7V to 18V
INPUT	Control input. TTL/CMOS compatible logic input
NC	No connection
GND	Ground
GND	Ground
$\overline{\text{OUTPUT}}$	CMOS push-pull, common to pin 7
$\overline{\text{OUTPUT}}$	CMOS push-pull, common to pin 6
V_{DD}	Supply input, 7V to 18V

DC ELECTRICAL CHARACTERISTICS

Electrical Specifications: Unless otherwise noted, $T_A = +25^\circ C$ with $7V \leq V_{DD} \leq 18V$.						
Parameters	Sym	Min	Typ	Max	Units	Conditions
Input						
Logic '1', High Input Voltage	V_{IH}	2.4	1.8	—	V	
Logic '0', Low Input Voltage	V_{IL}	—	1.3	0.8	V	
Input Current	I_{IN}	-10	—	10	μA	$0V \leq V_{IN} \leq V_{DD}$
Output						
High Output Voltage	V_{OH}	$V_{DD} - 0.025$	—	—	V	
Low Output Voltage	V_{OL}	—	—	0.025	V	
Output Resistance	R_O	—	1.8	2.5	Ω	$V_{IN} = 0.8V$, $V_{OUT} = 10 mA$, $V_{DD} = 18V$ $V_{IN} = 2.4V$, $V_{OUT} = 10 mA$, $V_{DD} = 18V$
Peak Output Current	I_{PK}	—	6.0	—	A	$V_{DD} = 18V$, Figure 4-4
Latch-Up Protection Withstand Reverse Current	I_{REV}	—	0.5	—	A	Duty cycle $\leq 2\%$, $t \leq 300 \mu sec$, $V_{DD} = 16V$
Switching Time (Note 1)						
Rise Time	t_R	—	23	35	nsec	$C_L = 2500 pF$, Figure 4-1
Fall Time	t_F	—	25	35	nsec	$C_L = 2500 pF$, Figure 4-1
Delay Time	t_{D1}	—	53	75	nsec	Figure 4-1
Delay Time	t_{D2}	—	60	75	nsec	Figure 4-1
Power Supply						
Power Supply Current	I_S	—	3.5	5.0	mA	$V_{IN} = 3V$ $V_{IN} = 0V$

Note 1: Switching times ensured by design.

TC429

DC ELECTRICAL CHARACTERISTICS (CONTINUED)

Electrical Specifications: Unless otherwise noted, over operating temperature range with $7V \leq V_{DD} \leq 18V$.						
Parameters	Sym	Min	Typ	Max	Units	Conditions
Input						
Logic '1', High Input Voltage	V_{IH}	2.4	—	—	V	
Logic '0', Low Input Voltage	V_{IL}	—	—	0.8	V	
Input Current	I_{IN}	-10	—	10	μA	$0V \leq V_{IN} \leq V_{DD}$
Output						
High Output Voltage	V_{OH}	$V_{DD} - 0.025$	—	—	V	
Low Output Voltage	V_{OL}	—	—	0.025	V	
Output Resistance	R_O	—	—	5.0	Ω	$V_{IN} = 0.8V$, $V_{OUT} = 10 mA$, $V_{DD} = 18V$
		—	—	5.0		$V_{IN} = 2.4V$, $V_{OUT} = 10 mA$, $V_{DD} = 18V$
Switching Time (Note 1)						
Rise Time	t_R	—	—	70	nsec	$C_L = 2500 pF$, Figure 4-1
Fall Time	t_F	—	—	70	nsec	$C_L = 2500 pF$, Figure 4-1
Delay Time	t_{D1}	—	—	100	nsec	Figure 4-1
Delay Time	t_{D2}	—	—	120	nsec	Figure 4-1
Power Supply						
Power Supply Current	I_S	—	—	12	mA	$V_{IN} = 3V$
		—	—	1.0		$V_{IN} = 0V$

Note 1: Switching times ensured by design.

TEMPERATURE CHARACTERISTICS

Electrical Specifications: Unless otherwise noted, $T_A = +25^\circ C$ with $7V \leq V_{DD} \leq 18V$.						
Parameters	Sym	Min	Typ	Max	Units	Conditions
Temperature Ranges						
Specified Temperature Range (C)	T_A	0	—	+70	$^\circ C$	
Specified Temperature Range (E)	T_A	-40	—	+85	$^\circ C$	
Specified Temperature Range (M)	T_A	-55	—	+125	$^\circ C$	
Maximum Junction Temperature	T_J	—	—	+150	$^\circ C$	
Storage Temperature Range	T_A	-65	—	+150	$^\circ C$	
Package Thermal Resistances						
Thermal Resistance, 8L-CERDIP	θ_{JA}	—	150	—	$^\circ C/W$	
Thermal Resistance, 8L-PDIP	θ_{JA}	—	125	—	$^\circ C/W$	
Thermal Resistance, 8L-SOIC	θ_{JA}	—	155	—	$^\circ C/W$	

2.0 TYPICAL PERFORMANCE CURVES

Note: The graphs and tables provided following this note are a statistical summary based on a limited number of samples and are provided for informational purposes only. The performance characteristics listed herein are not tested or guaranteed. In some graphs or tables, the data presented may be outside the specified operating range (e.g., outside specified power supply range) and therefore outside the warranted range.

Note: Unless otherwise indicated, $T_A = +25^\circ\text{C}$ with $7\text{V} \leq V_{DD} \leq 18\text{V}$.

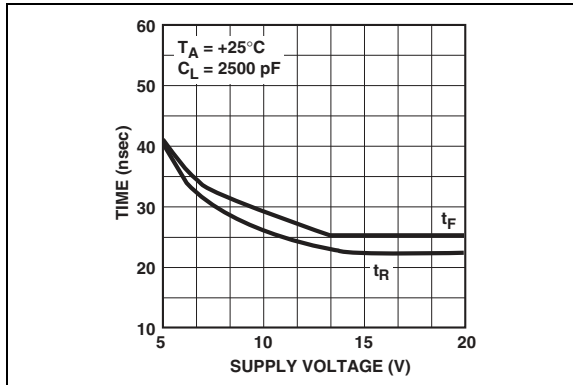

FIGURE 2-1: Rise/Fall Times vs. Supply Voltage.

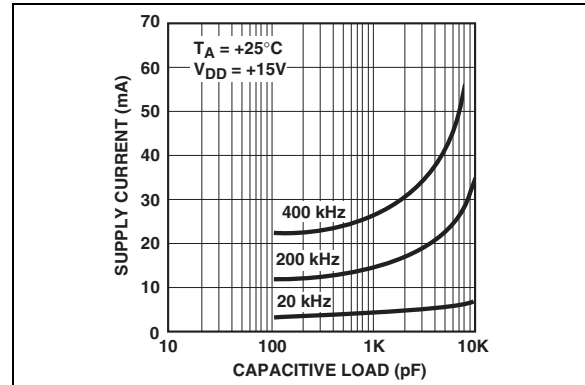

FIGURE 2-4: Supply Current vs. Capacitive Load.

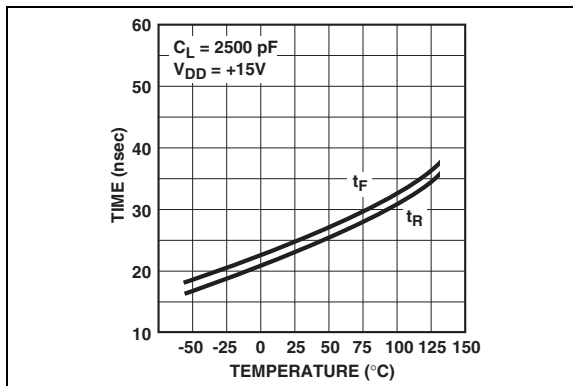

FIGURE 2-2: Rise/Fall Times vs. Temperature.

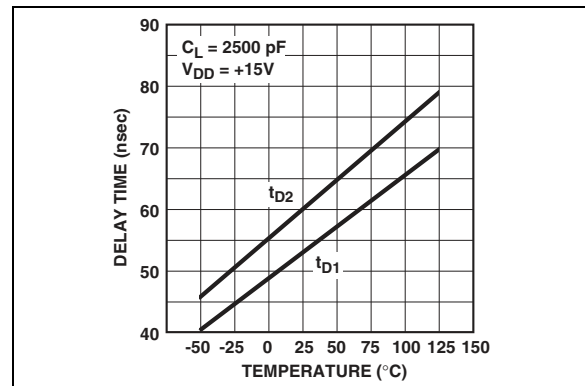

FIGURE 2-5: Delay Times vs. Temperature.

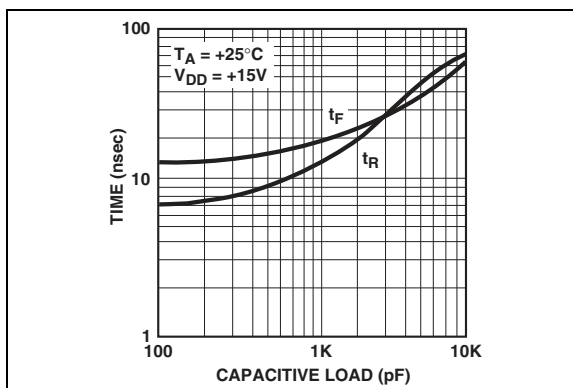

FIGURE 2-3: Rise/Fall Times vs. Capacitive Load.

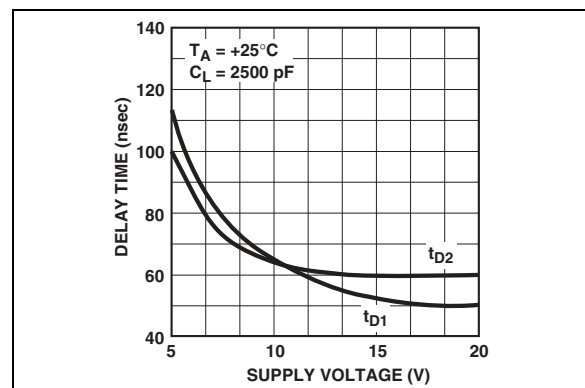

FIGURE 2-6: Delay Times vs. Supply Voltage.

TC429

Note: Unless otherwise indicated, $T_A = +25^\circ\text{C}$ with $7\text{V} \leq V_{DD} \leq 18\text{V}$.

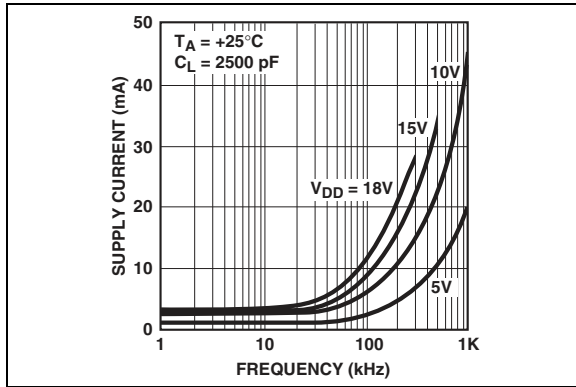

FIGURE 2-7: Supply Current vs. Frequency.

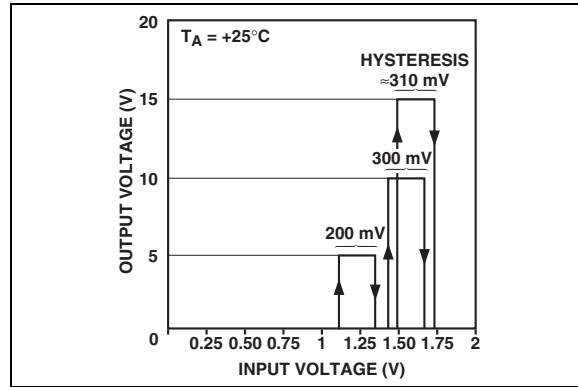

FIGURE 2-10: Voltage Transfer Characteristics.

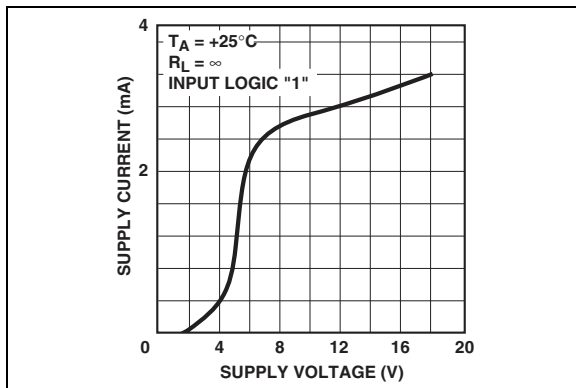

FIGURE 2-8: Supply Current vs. Supply Voltage.

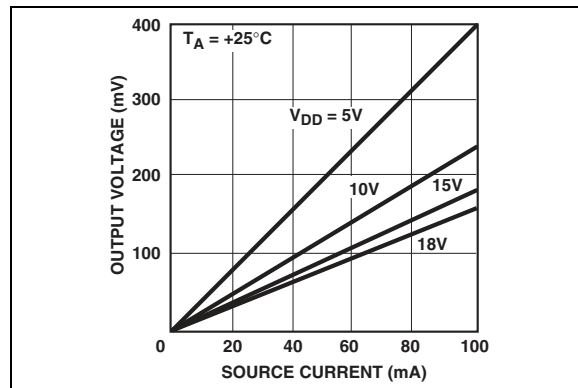

FIGURE 2-11: High Output Voltage ($V_{DD} - V_{OH}$) vs. Output Source Current.

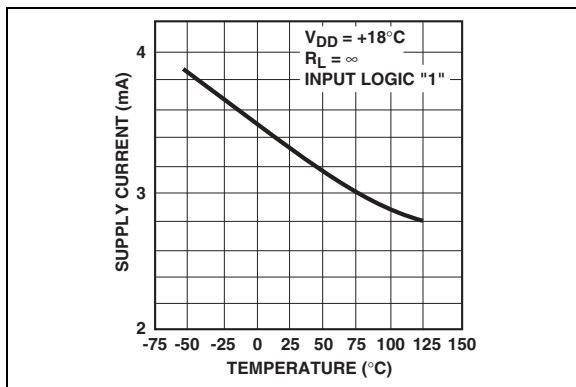

FIGURE 2-9: Supply Current vs. Temperature.

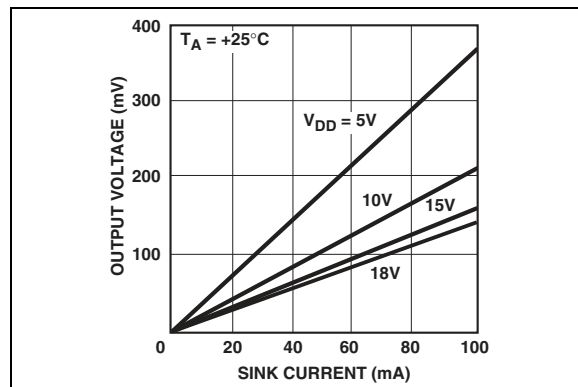

FIGURE 2-12: Low Output Voltage vs. Output Sink Current.

3.0 PIN DESCRIPTIONS

The descriptions of the pins are listed in Table 3-1.

TABLE 3-1: PIN FUNCTION TABLE

Pin No.	Symbol	Description
1	V_{DD}	Supply input, 7V to 18V
2	INPUT	Control input. TTL/CMOS compatible logic input
3	NC	No connection
4	GND	Ground
5	GND	Ground
6	$\overline{\text{OUTPUT}}$	CMOS push-pull output, common to pin 7
7	$\overline{\text{OUTPUT}}$	CMOS push-pull output, common to pin 6
8	V_{DD}	Supply input, 7V to 18V

3.1 Supply Input (V_{DD})

The V_{DD} input is the bias supply for the MOSFET driver and is rated for 7.0V to 18V with respect to the ground pin. The V_{DD} input should be bypassed to ground with a local ceramic capacitor. The value of the capacitor should be chosen based on the capacitive load that is being driven. A value of 1.0 μF is suggested.

3.2 Control Input (INPUT)

The MOSFET driver input is a high-impedance, TTL/CMOS compatible input. The input also has 300 mV of hysteresis between the high and low thresholds that prevents output glitching even when the rise and fall time of the input signal is very slow.

3.3 CMOS Push-Pull Output (OUTPUT)

The MOSFET driver output is a low-impedance, CMOS push-pull style output, capable of driving a capacitive load with 6.0A peak currents.

3.4 Ground (GND)

The ground pins are the return path for the bias current and for the high peak currents that discharge the load capacitor. The ground pins should be tied into a ground plane or have very short traces to the bias supply source return.

3.5 No Connect (NC)

No connection.

TC429

4.0 APPLICATIONS INFORMATION

4.1 Supply Bypassing

Charging and discharging large capacitive loads quickly requires large currents. For example, charging a 2500 pF load to 18V in 25 nsec requires a 1.8A current from the device's power supply.

To ensure low supply impedance over a wide frequency range, a parallel capacitor combination is recommended for supply bypassing. Low-inductance ceramic disk capacitors with short lead lengths (< 0.5 in.) should be used. A 1 μF film capacitor in parallel with one or two 0.1 μF ceramic disk capacitors normally provides adequate bypassing.

4.2 Grounding

The high-current capability of the TC429 demands careful PC board layout for best performance. Since the TC429 is an inverting driver, any ground lead impedance will appear as negative feedback that can degrade switching speed. The feedback is especially noticeable with slow rise-time inputs, such as those produced by an open-collector output with resistor pull-up. The TC429 input structure includes about 300 mV of hysteresis to ensure clean transitions and freedom from oscillation, but attention to layout is still recommended.

Figure 4-3 shows the feedback effect in detail. As the TC429 input begins to go positive, the output goes negative and several amperes of current flow in the ground lead. A PC trace resistance of as little as 0.05 Ω can produce hundreds of millivolts at the TC429 ground pins. If the driving logic is referenced to power ground, the effective logic input level is reduced and oscillations may result.

To ensure optimum device performance, separate ground traces should be provided for the logic and power connections. Connecting logic ground directly to the TC429 GND pins ensures full logic drive to the input and fast output switching. Both GND pins should be connected to power ground.

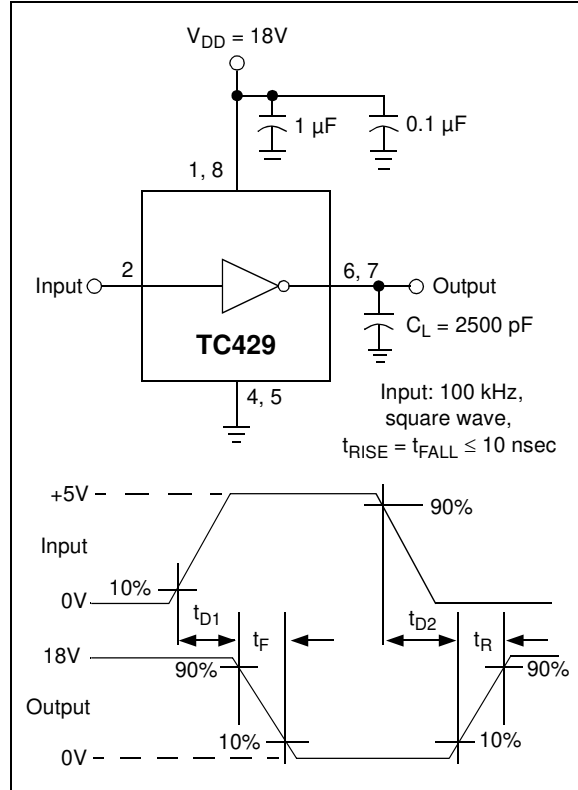

FIGURE 4-1: Inverting Driver Switching Time Test Circuit.

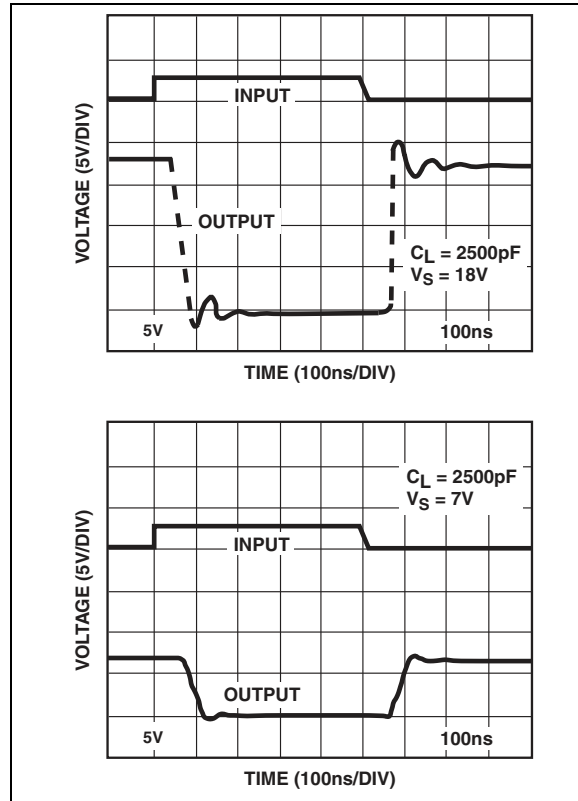

FIGURE 4-2: Switching Speed.

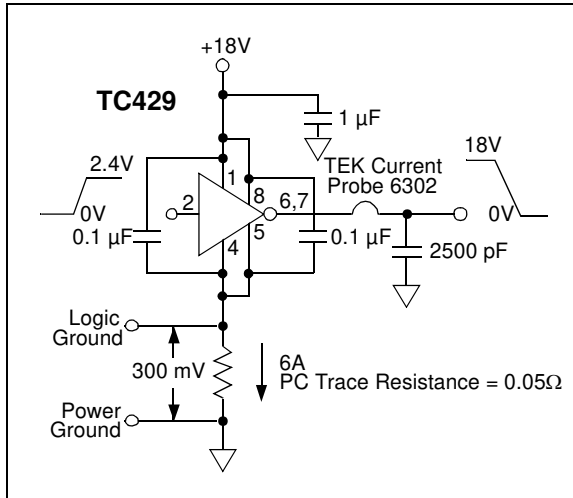

FIGURE 4-3: Switching Time Degradation Due To Negative Feedback.

4.3 Input Stage

The input voltage level changes the no-load or quiescent supply current. The N-channel MOSFET input stage transistor drives a 3 mA current source load. With a logic '1' input, the maximum quiescent supply current is 5 mA. Logic '0' input level signals reduce quiescent current to 500 μ A maximum.

The TC429 input is designed to provide 300 mV of hysteresis, providing clean transitions and minimizing output stage current spiking when changing states. Input voltage levels are approximately 1.5V, making the device TTL-compatible over the 7V to 18V operating supply range. Input pin current draw is less than 10 μ A over this range.

The TC429 can be directly driven by TL494, SG1526/1527, SG1524, SE5560 or similar switch-mode power supply integrated circuits. By off-loading the power-driving duties to the TC429, the power supply controller can operate at lower dissipation, improving performance and reliability.

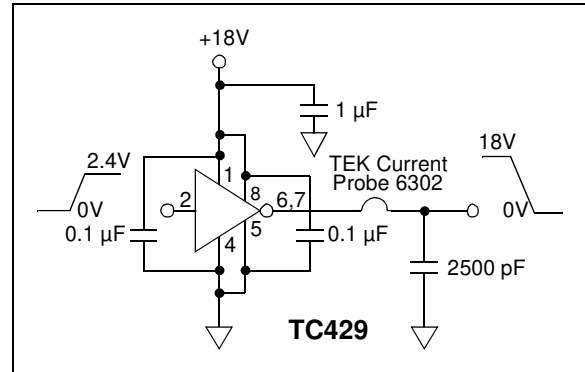

FIGURE 4-4: Peak Output Current Test Circuit.

4.4 Power Dissipation

CMOS circuits usually permit the user to ignore power dissipation. Logic families such as the 4000 and 74C have outputs that can only supply a few milliamperes of current, and even shorting outputs to ground will not force enough current to destroy the device. The TC429, however, can source or sink several amperes and drive large capacitive loads at high frequency. Since the package power dissipation limit can easily be exceeded, some attention should be given to power dissipation when driving low-impedance loads and/or operating at high frequency.

The supply current versus frequency and supply current versus capacitive load characteristic curves will aid in determining power dissipation calculations. Table 4-1 lists the maximum operating frequency for several power supply voltages when driving a 2500 pF load. More accurate power dissipation figures can be obtained by summing the three components that make up the total device power dissipation.

Input signal duty cycle, power supply voltage and capacitive load influence package power dissipation. Given power dissipation and package thermal resistance, the maximum ambient operation temperature is easily calculated. The 8-pin Cerdip junction-to-ambient thermal resistance is 150°C/W. At +25°C, the package is rated at 800 mW maximum dissipation. Maximum allowable junction temperature is +150°C.

Three components make up total package power dissipation:

- Capacitive load dissipation (P_C)
- Quiescent power (P_Q)
- Transition power (P_T)

The capacitive load-caused dissipation is a direct function of frequency, capacitive load and supply voltage.

TC429

The device capacitive load dissipation is:

EQUATION

$$P_C = fCV_S^2$$

Where:

f = Switching frequency
C = Capacitive load
V_S = Supply voltage

Quiescent power dissipation depends on input signal duty cycle. A logic low input results in a low-power dissipation mode with only 0.5 mA total current drain. Logic-high signals raise the current to 5 mA maximum.

The quiescent power dissipation is:

EQUATION

$$P_Q = V_S(D(I_H) + (1-D)I_L)$$

Where:

I_H = Quiescent current with input high
(5 mA max)
I_L = Quiescent current with input low
(0.5 mA max)
D = Duty cycle

Transition power dissipation arises because the output stage N- and P-channel MOS transistors are ON simultaneously for a very short period when the output changes.

The device transition power dissipation is approximately:

EQUATION

$$P_T = fV_S(3.3 \times 10^{-9} A \cdot Sec)$$

An example shows the relative magnitude for each item.

C = 2500 pF
V_S = 15V
D = 50%
f = 200 kHz
P_D = Package power dissipation:
= P_C + P_T + P_Q
= 113 mW + 10 mW + 41 mW
= 164 mW

Maximum ambient operating temperature:

= T_J - θ_{JA} (P_D)
= 150°C - (150°C/W)(0.164W)
= 125°C

Where:

T_J = Maximum allowable junction temperature
(+150°C)
θ_{JA} = Junction-to-ambient thermal resistance
(150°C/W, CERDIP)

Note: Ambient operating temperature should not exceed +85°C for EPA or EOA devices or +125°C for MJA devices.

TABLE 4-1: MAXIMUM OPERATING FREQUENCIES

V _S	f _{MAX}
18V	500 kHz
15V	700 kHz
10V	1.3 MHz
5V	>2 MHz

Conditions:

1. CERDIP Package (θ_{JA} = 150°C/W)
2. T_A = +25°C
3. C_L = 2500 pF

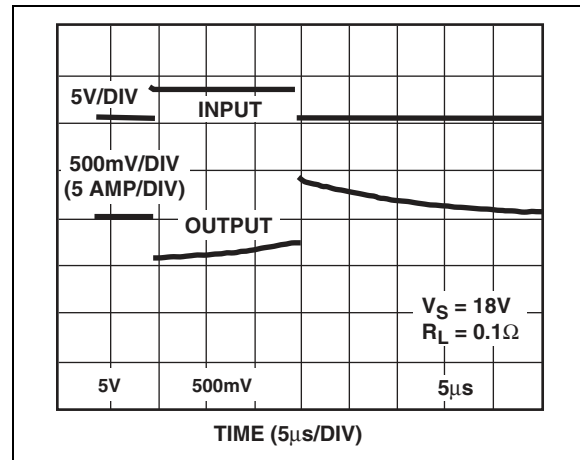

FIGURE 4-5: Peak Output Current Capability.

4.5 POWER-ON OSCILLATION

Note: It is extremely important that all MOSFET driver applications be evaluated for the possibility of having high-power oscillations occur during the power-on cycle.

Power-on oscillations are due to trace size, layout and component placement. A 'quick fix' for most applications that exhibit power-on oscillation problems is to place approximately 10 kΩ in series with the input of the MOSFET driver.

5.0 PACKAGING INFORMATION

5.1 Package Marking Information

8-Lead PDIP (300 mil)

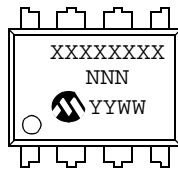

Example:

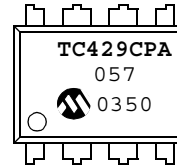

8-Lead CERDIP (300 mil)

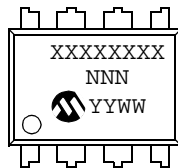

Example:

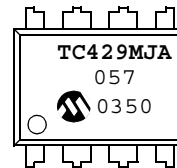

8-Lead SOIC (150 mil)

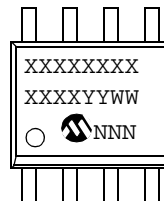

Example:

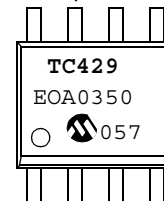

Legend:	XX...X	Customer-specific information
	Y	Year code (last digit of calendar year)
	YY	Year code (last 2 digits of calendar year)
	WW	Week code (week of January 1 is week '01')
	NNN	Alphanumeric traceability code
	(e3)	Pb-free JEDEC designator for Matte Tin (Sn)
	*	This package is Pb-free. The Pb-free JEDEC designator (e3) can be found on the outer packaging for this package.

Note: In the event the full Microchip part number cannot be marked on one line, it will be carried over to the next line, thus limiting the number of available characters for customer-specific information.

TC429

8-Lead Plastic Dual In-line (PA) – 300 mil (PDIP)

Note: For the most current package drawings, please see the Microchip Packaging Specification located at <http://www.microchip.com/packaging>

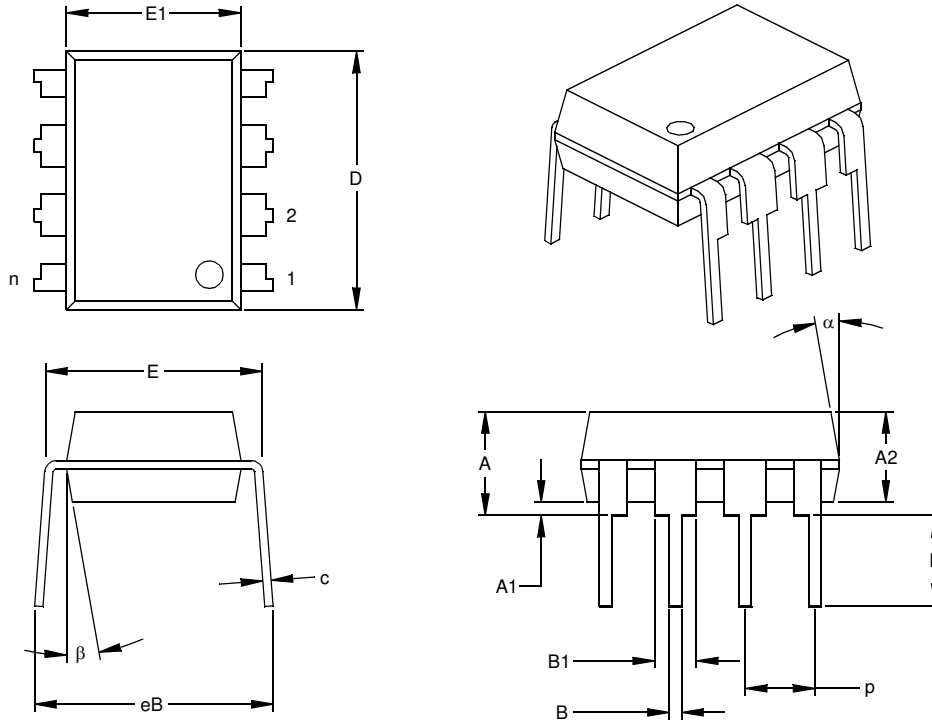

Units		INCHES*			MILLIMETERS		
Dimension Limits		MIN	NOM	MAX	MIN	NOM	MAX
Number of Pins	n		8			8	
Pitch	p		.100			2.54	
Top to Seating Plane	A	.140	.155	.170	3.56	3.94	4.32
Molded Package Thickness	A2	.115	.130	.145	2.92	3.30	3.68
Base to Seating Plane	A1	.015			0.38		
Shoulder to Shoulder Width	E	.300	.313	.325	7.62	7.94	8.26
Molded Package Width	E1	.240	.250	.260	6.10	6.35	6.60
Overall Length	D	.360	.373	.385	9.14	9.46	9.78
Tip to Seating Plane	L	.125	.130	.135	3.18	3.30	3.43
Lead Thickness	c	.008	.012	.015	0.20	0.29	0.38
Upper Lead Width	B1	.045	.058	.070	1.14	1.46	1.78
Lower Lead Width	B	.014	.018	.022	0.36	0.46	0.56
Overall Row Spacing	§ eB	.310	.370	.430	7.87	9.40	10.92
Mold Draft Angle Top	a	5	10	15	5	10	15
Mold Draft Angle Bottom	b	5	10	15	5	10	15

* Controlling Parameter

§ Significant Characteristic

Notes:

Dimensions D and E1 do not include mold flash or protrusions. Mold flash or protrusions shall not exceed .010" (0.254mm) per side.

JEDEC Equivalent: MS-001

Drawing No. C04-018

8-Lead Ceramic Dual In-line – 300 mil (CERDIP)

Note: For the most current package drawings, please see the Microchip Packaging Specification located at <http://www.microchip.com/packaging>

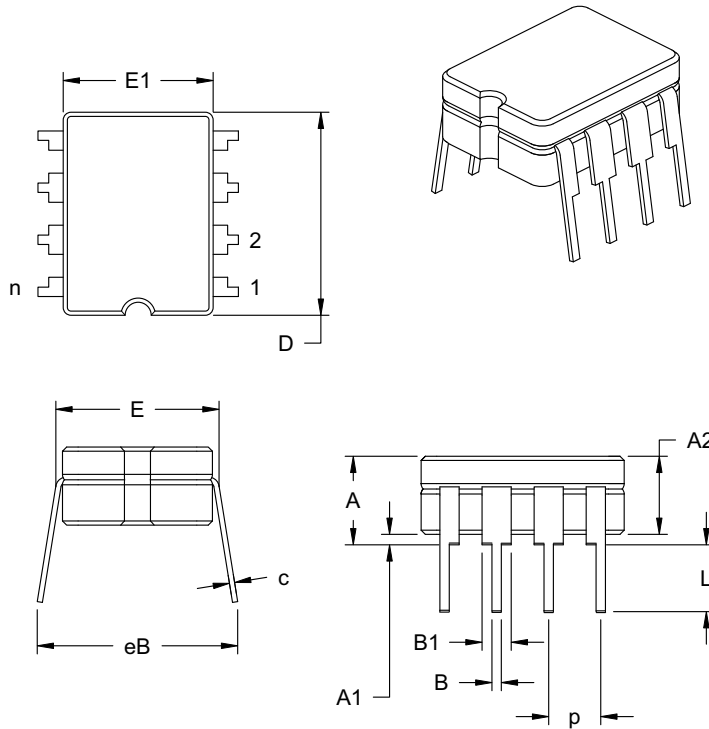

Dimension Limits	Units	INCHES*			MILLIMETERS		
		MIN	NOM	MAX	MIN	NOM	MAX
Number of Pins	n		8			8	
Pitch	p		.100			2.54	
Top to Seating Plane	A	.160	.180	.200	4.06	4.57	5.08
Standoff §	A1	.020	.030	.040	0.51	0.77	1.02
Shoulder to Shoulder Width	E	.290	.305	.320	7.37	7.75	8.13
Ceramic Pkg. Width	E1	.230	.265	.300	5.84	6.73	7.62
Overall Length	D	.370	.385	.400	9.40	9.78	10.16
Tip to Seating Plane	L	.125	.163	.200	3.18	4.13	5.08
Lead Thickness	c	.008	.012	.015	0.20	0.29	0.38
Upper Lead Width	B1	.045	.055	.065	1.14	1.40	1.65
Lower Lead Width	B	.016	.018	.020	0.41	0.46	0.51
Overall Row Spacing	eB	.320	.360	.400	8.13	9.15	10.16

*Controlling Parameter

JEDEC Equivalent: MS-030

Drawing No. C04-010

TC429

8-Lead Plastic Small Outline (OA) – Narrow, 150 mil (SOIC)

Note: For the most current package drawings, please see the Microchip Packaging Specification located at <http://www.microchip.com/packaging>

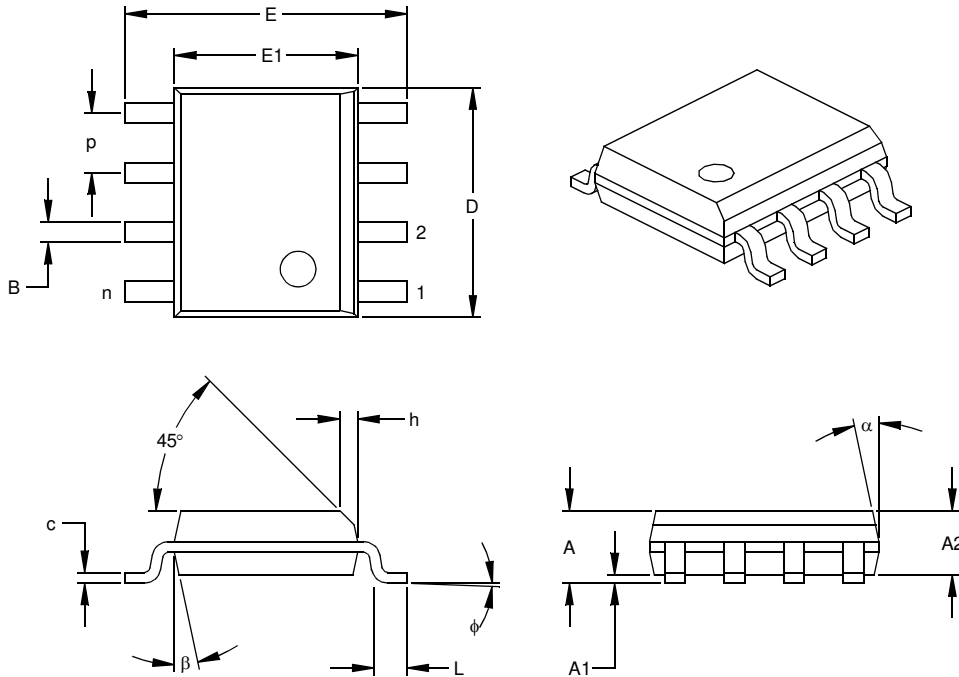

Dimension Limits	Units	INCHES*			MILLIMETERS		
		MIN	NOM	MAX	MIN	NOM	MAX
Number of Pins	n		8			8	
Pitch	p		.050			1.27	
Overall Height	A	.053	.061	.069	1.35	1.55	1.75
Molded Package Thickness	A2	.052	.056	.061	1.32	1.42	1.55
Standoff §	A1	.004	.007	.010	0.10	0.18	0.25
Overall Width	E	.228	.237	.244	5.79	6.02	6.20
Molded Package Width	E1	.146	.154	.157	3.71	3.91	3.99
Overall Length	D	.189	.193	.197	4.80	4.90	5.00
Chamfer Distance	h	.010	.015	.020	0.25	0.38	0.51
Foot Length	L	.019	.025	.030	0.48	0.62	0.76
Foot Angle	φ	0	4	8	0	4	8
Lead Thickness	c	.008	.009	.010	0.20	0.23	0.25
Lead Width	B	.013	.017	.020	0.33	0.42	0.51
Mold Draft Angle Top	α	0	12	15	0	12	15
Mold Draft Angle Bottom	β	0	12	15	0	12	15

* Controlling Parameter
 § Significant Characteristic

Notes:
 Dimensions D and E1 do not include mold flash or protrusions. Mold flash or protrusions shall not exceed .010" (0.254mm) per side.
 JEDEC Equivalent: MS-012
 Drawing No. C04-057

6.0 REVISION HISTORY

Revision D (December 2012)

Added a note to each package outline drawing.

TC429

NOTES:

PRODUCT IDENTIFICATION SYSTEM

To order or obtain information, e.g., on pricing or delivery, refer to the factory or the listed sales office.

<u>PART NO.</u>	<u>X</u>	<u>/XX</u>
Device	Temperature Range	Package
Device:	TC429:	6A Single MOSFET Driver
Temperature Range:	C =	0°C to +70°C
	E =	-40°C to +85°C
	M =	-55°C to +125°C (CERDIP only)
Package:	JA =	Plastic CERDIP, (300 mil Body), 8-lead
	OA =	Plastic SOIC, (150 mil Body), 8-lead *
	OA713 =	Plastic SOIC, (150 mil Body), 8-lead * (Tape and Reel)
	PA =	Plastic DIP (300 mil Body), 8-lead
	* SOIC package offered in E-Temp only	

Examples:

- a) TC429CPA: 6A Single MOSFET driver, PDIP package, 0°C to +70°C.
- b) TC429MJA: 6A Single MOSFET driver, CERDIP package, -55°C to +125°C.
- c) TC429EPA: 6A Single MOSFET driver, PDIP package, -40°C to +85°C.
- d) TC429EOA713: Tape and Reel, 6A Single MOSFET driver, SOIC package, -40°C to +85°C.

Sales and Support

Data Sheets

Products supported by a preliminary Data Sheet may have an errata sheet describing minor operational differences and recommended workarounds. To determine if an errata sheet exists for a particular device, please contact one of the following:

1. Your local Microchip sales office
2. The Microchip Worldwide Site (www.microchip.com)

Please specify which device, revision of silicon and Data Sheet (include Literature #) you are using.

Customer Notification System

Register on our web site (www.microchip.com/cn) to receive the most current information on our products.

TC429

NOTES:

Note the following details of the code protection feature on Microchip devices:

- Microchip products meet the specification contained in their particular Microchip Data Sheet.
- Microchip believes that its family of products is one of the most secure families of its kind on the market today, when used in the intended manner and under normal conditions.
- There are dishonest and possibly illegal methods used to breach the code protection feature. All of these methods, to our knowledge, require using the Microchip products in a manner outside the operating specifications contained in Microchip's Data Sheets. Most likely, the person doing so is engaged in theft of intellectual property.
- Microchip is willing to work with the customer who is concerned about the integrity of their code.
- Neither Microchip nor any other semiconductor manufacturer can guarantee the security of their code. Code protection does not mean that we are guaranteeing the product as “unbreakable.”

Code protection is constantly evolving. We at Microchip are committed to continuously improving the code protection features of our products. Attempts to break Microchip's code protection feature may be a violation of the Digital Millennium Copyright Act. If such acts allow unauthorized access to your software or other copyrighted work, you may have a right to sue for relief under that Act.

Information contained in this publication regarding device applications and the like is provided only for your convenience and may be superseded by updates. It is your responsibility to ensure that your application meets with your specifications. MICROCHIP MAKES NO REPRESENTATIONS OR WARRANTIES OF ANY KIND WHETHER EXPRESS OR IMPLIED, WRITTEN OR ORAL, STATUTORY OR OTHERWISE, RELATED TO THE INFORMATION, INCLUDING BUT NOT LIMITED TO ITS CONDITION, QUALITY, PERFORMANCE, MERCHANTABILITY OR FITNESS FOR PURPOSE. Microchip disclaims all liability arising from this information and its use. Use of Microchip devices in life support and/or safety applications is entirely at the buyer's risk, and the buyer agrees to defend, indemnify and hold harmless Microchip from any and all damages, claims, suits, or expenses resulting from such use. No licenses are conveyed, implicitly or otherwise, under any Microchip intellectual property rights.

Trademarks

The Microchip name and logo, the Microchip logo, dsPIC, FlashFlex, KEELOQ, KEELOQ logo, MPLAB, PIC, PICmicro, PICSTART, PIC³² logo, rPIC, SST, SST Logo, SuperFlash and UNI/O are registered trademarks of Microchip Technology Incorporated in the U.S.A. and other countries.

FilterLab, Hampshire, HI-TECH C, Linear Active Thermistor, MTP, SEEVAL and The Embedded Control Solutions Company are registered trademarks of Microchip Technology Incorporated in the U.S.A.

Silicon Storage Technology is a registered trademark of Microchip Technology Inc. in other countries.

Analog-for-the-Digital Age, Application Maestro, BodyCom, chipKIT, chipKIT logo, CodeGuard, dsPICDEM, dsPICDEM.net, dsPICworks, dsSPEAK, ECAN, ECONOMONITOR, FanSense, HI-TIDE, In-Circuit Serial Programming, ICSP, Mindi, MiWi, MPASM, MPF, MPLAB Certified logo, MPLIB, MPLINK, mTouch, Omniclient Code Generation, PICC, PICC-18, PICDEM, PICDEM.net, PICkit, PICtail, REAL ICE, rLAB, Select Mode, SQI, Serial Quad I/O, Total Endurance, TSHARC, UniWinDriver, WiperLock, ZENA and Z-Scale are trademarks of Microchip Technology Incorporated in the U.S.A. and other countries.

SQTP is a service mark of Microchip Technology Incorporated in the U.S.A.

GestIC and ULPP are registered trademarks of Microchip Technology Germany II GmbH & Co. & KG, a subsidiary of Microchip Technology Inc., in other countries.

All other trademarks mentioned herein are property of their respective companies.

© 2002-2012, Microchip Technology Incorporated, Printed in the U.S.A., All Rights Reserved.

 Printed on recycled paper.

ISBN: 9781620767917

QUALITY MANAGEMENT SYSTEM
CERTIFIED BY DNV
== ISO/TS 16949 ==

Microchip received ISO/TS-16949:2009 certification for its worldwide headquarters, design and wafer fabrication facilities in Chandler and Tempe, Arizona; Gresham, Oregon and design centers in California and India. The Company's quality system processes and procedures are for its PIC[®] MCUs and dsPIC[®] DSCs, KEELOQ[®] code hopping devices, Serial EEPROMs, microperipherals, nonvolatile memory and analog products. In addition, Microchip's quality system for the design and manufacture of development systems is ISO 9001:2000 certified.



MICROCHIP

Worldwide Sales and Service

AMERICAS

Corporate Office
2355 West Chandler Blvd.
Chandler, AZ 85224-6199
Tel: 480-792-7200
Fax: 480-792-7277
Technical Support:
<http://www.microchip.com/support>
Web Address:
www.microchip.com

Atlanta
Duluth, GA
Tel: 678-957-9614
Fax: 678-957-1455

Boston
Westborough, MA
Tel: 774-760-0087
Fax: 774-760-0088

Chicago
Itasca, IL
Tel: 630-285-0071
Fax: 630-285-0075

Cleveland
Independence, OH
Tel: 216-447-0464
Fax: 216-447-0643

Dallas
Addison, TX
Tel: 972-818-7423
Fax: 972-818-2924

Detroit
Farmington Hills, MI
Tel: 248-538-2250
Fax: 248-538-2260

Indianapolis
Noblesville, IN
Tel: 317-773-8323
Fax: 317-773-5453

Los Angeles
Mission Viejo, CA
Tel: 949-462-9523
Fax: 949-462-9608

Santa Clara
Santa Clara, CA
Tel: 408-961-6444
Fax: 408-961-6445

Toronto
Mississauga, Ontario,
Canada
Tel: 905-673-0699
Fax: 905-673-6509

ASIA/PACIFIC

Asia Pacific Office
Suites 3707-14, 37th Floor
Tower 6, The Gateway
Harbour City, Kowloon
Hong Kong
Tel: 852-2401-1200
Fax: 852-2401-3431

Australia - Sydney
Tel: 61-2-9868-6733
Fax: 61-2-9868-6755

China - Beijing
Tel: 86-10-8569-7000
Fax: 86-10-8528-2104

China - Chengdu
Tel: 86-28-8665-5511
Fax: 86-28-8665-7889

China - Chongqing
Tel: 86-23-8980-9588
Fax: 86-23-8980-9500

China - Hangzhou
Tel: 86-571-2819-3187
Fax: 86-571-2819-3189

China - Hong Kong SAR
Tel: 852-2943-5100
Fax: 852-2401-3431

China - Nanjing
Tel: 86-25-8473-2460
Fax: 86-25-8473-2470

China - Qingdao
Tel: 86-532-8502-7355
Fax: 86-532-8502-7205

China - Shanghai
Tel: 86-21-5407-5533
Fax: 86-21-5407-5066

China - Shenyang
Tel: 86-24-2334-2829
Fax: 86-24-2334-2393

China - Shenzhen
Tel: 86-755-8864-2200
Fax: 86-755-8203-1760

China - Wuhan
Tel: 86-27-5980-5300
Fax: 86-27-5980-5118

China - Xian
Tel: 86-29-8833-7252
Fax: 86-29-8833-7256

China - Xiamen
Tel: 86-592-2388138
Fax: 86-592-2388130

China - Zhuhai
Tel: 86-756-3210040
Fax: 86-756-3210049

ASIA/PACIFIC

India - Bangalore
Tel: 91-80-3090-4444
Fax: 91-80-3090-4123

India - New Delhi
Tel: 91-11-4160-8631
Fax: 91-11-4160-8632

India - Pune
Tel: 91-20-2566-1512
Fax: 91-20-2566-1513

Japan - Osaka
Tel: 81-66-152-7160
Fax: 81-66-152-9310

Japan - Yokohama
Tel: 81-45-471-6166
Fax: 81-45-471-6122

Korea - Daegu
Tel: 82-53-744-4301
Fax: 82-53-744-4302

Korea - Seoul
Tel: 82-2-554-7200
Fax: 82-2-558-5932 or
82-2-558-5934

Malaysia - Kuala Lumpur
Tel: 60-3-6201-9857
Fax: 60-3-6201-9859

Malaysia - Penang
Tel: 60-4-227-8870
Fax: 60-4-227-4068

Philippines - Manila
Tel: 63-2-634-9065
Fax: 63-2-634-9069

Singapore
Tel: 65-6334-8870
Fax: 65-6334-8850

Taiwan - Hsin Chu
Tel: 886-3-5778-366
Fax: 886-3-5770-955

Taiwan - Kaohsiung
Tel: 886-7-213-7828
Fax: 886-7-330-9305

Taiwan - Taipei
Tel: 886-2-2508-8600
Fax: 886-2-2508-0102

Thailand - Bangkok
Tel: 66-2-694-1351
Fax: 66-2-694-1350

EUROPE

Austria - Wels
Tel: 43-7242-2244-39
Fax: 43-7242-2244-393

Denmark - Copenhagen
Tel: 45-4450-2828
Fax: 45-4485-2829

France - Paris
Tel: 33-1-69-53-63-20
Fax: 33-1-69-30-90-79

Germany - Munich
Tel: 49-89-627-144-0
Fax: 49-89-627-144-44

Italy - Milan
Tel: 39-0331-742611
Fax: 39-0331-466781

Netherlands - Drunen
Tel: 31-416-690399
Fax: 31-416-690340

Spain - Madrid
Tel: 34-91-708-08-90
Fax: 34-91-708-08-91

UK - Wokingham
Tel: 44-118-921-5869
Fax: 44-118-921-5820

11/27/12