

Board Level Heat Sinks

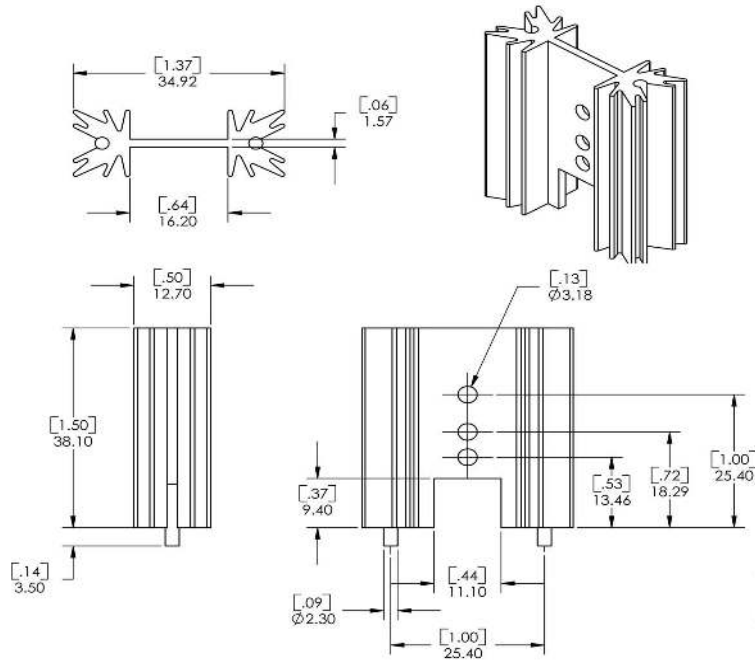

ThermaFlo

P/N: 411915B02500



PRODUCT SPECIFICATIONS

- Devices: TO-202 & TO-220
- Size: 12.7 x 34.9 x 38.1 mm
- Material: Aluminum
- Weight: 15.7 grams
- Type: Extruded
- PCB Mounting: Solderable Pins
- Finish: Black Anodized
- Package: Bulk
- Accessories: Hardware & Thermal Interface Material

FEATURES & BENEFITS

- Multiple Holes for Device Attachment
- Dual Device Cooling Heat Sink
- Vertical Mounting via Solderable Pins
- RoHS Compliant



CUSTOMIZED HEATSINKS

- Specialized Plating
- Specialized Body Configurations
- Contact Applications Engineering

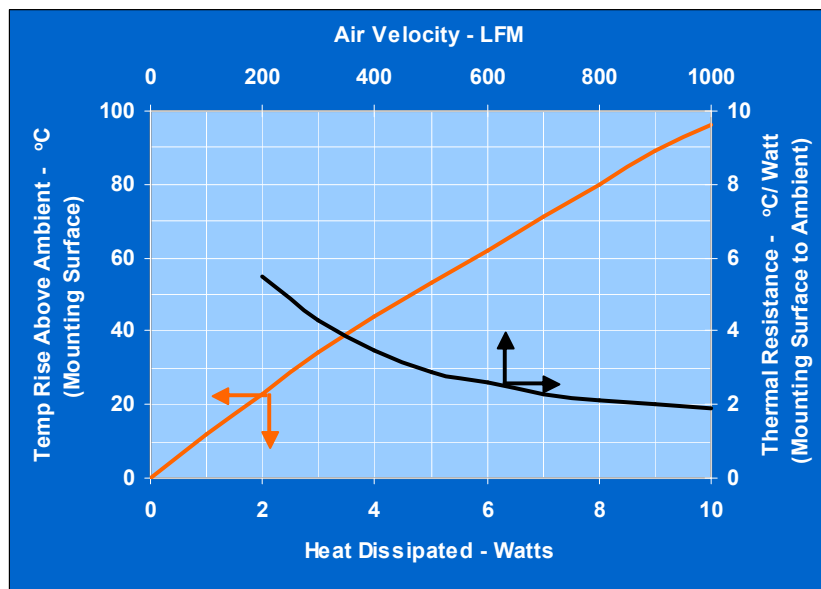

TO-202 & TO-220

COMAIR ROTRON, INC
 8929 Terman Court, San Diego, CA 92121
 Ph (858) 348-6200 Fax (858) 566-4577
 E-mail: sales@comairrotron.com,
 Web: www.comairrotron.com