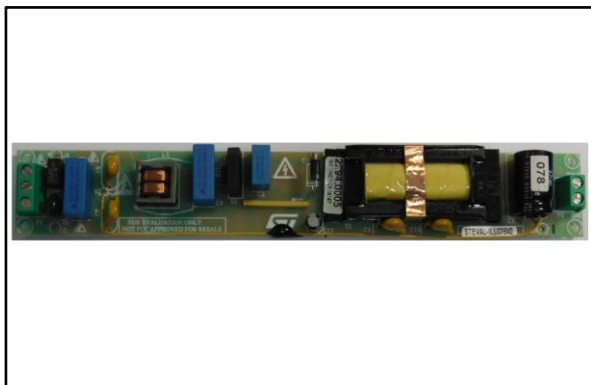

---

**18 W wide input range ultra slim flyback converter using HVLED001A quasi resonant flyback controller and STD8N80K5**

---

Data brief

**Features**

- Input voltage:  $V_{in}$ : 90 – 264 Vrms, f: 45 – 66 Hz
- Output power:
  - 18 W at wide input range
  - 40 W at European input range
- Output voltage: 56 V  $\pm$ 5 %
- High power factor, low THD
- No-load: better than 400 mW at 230 V<sub>in</sub>
- Full load efficiency: greater than 92 %
- Short circuit protection with auto restart
- EMI: pre-compliant with EN55022 (B) limits
- Safety: complies with EN60950
- Dimensions: 183 mm x 28 mm x 17 mm
- PCB: single sided, 35  $\mu$ m, FR4, mixed PTH/SMD
- RoHS compliant

**Description**

This board implements an offline power converter based on a single stage high-PF flyback topology using the HVLED001A controller.

A very slim form factor is achieved with innovative magnetic componentry.

The output voltage is controlled by the primary side, thus reducing the need for costly opto-couplers. The HVLED001A PSR precision and the innovative structure of the transformer makes for highly accurate output voltage regulation against load and line changes.

A very high efficiency is obtained and a full set of protections including output short circuit and input overvoltage is included.

Conducted EMI is pre-screened and clearances and creepage distances adhere to EN60950 safety requirements.

Power factor and THD are optimized to be respectively higher than 0.95 and lower than 10% at full load over the entire input voltage range.

The main application for this converter is for bus power supplies in a LED string driver providing 4 kV isolation.

# 1 Schematic diagram and bill of materials

Figure 1: STEVAL-ILL076V2 circuit schematic

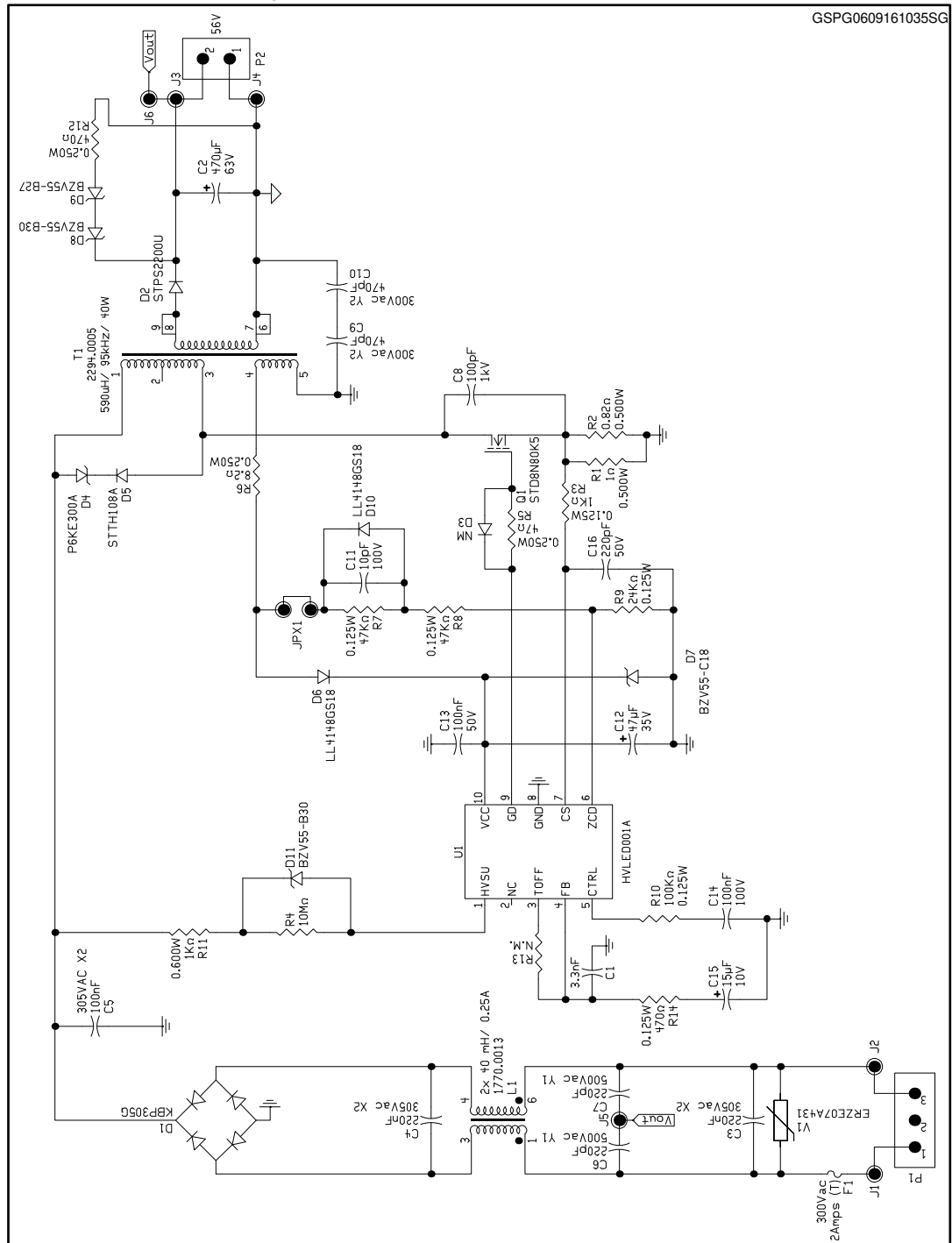

Table 1: Board bill of materials

Q.ty	Reference	Part / Value	Voltage / Watt / Ampere	Tolerance
1	C1	3.3 nF	50 V	10%
1	C2	470 $\mu$ F	63 V	10%
2	C3, C4	220 nF	305 Vac X2	10%
1	C5	100 nF	305 Vac X2	10%
2	C6, C7	220 pF	500 Vac Y1	10%
1	C8	100 pF	1 kV	10%
2	C9, C10	470 pF	300 Vac Y2	10%
1	C11	10 pF	100 V	10%
1	C12	47 $\mu$ F	35 V	10%
2	C13, C14	100 nF	100 V	10%
1	C15	15 $\mu$ F	10 V	10%
1	C16	220 pF	50 V	10%
1	D1	KBP305G	600 V / 3 A	
1	D2	STPS2200U	200 V / 2 A	
0	D3	NM		
1	D4	P6KE300A	300 V	
1	D5	STTH108A	800 V / 1 A	
2	D6, D10	LL4148GS18		
1	D7	BZV55-C18	Zener 18 V	
2	D8, D11	BZV55-B30	Zener 30 V	
1	D9	BZV55-B27	Zener 27 V	
1	F1	2 Amps (T)	300 Vac	
1	JPX1		20.5 mm	
1	JPX2		171 mm TIW	
1	L1	1770.0013	2x 40 mH/ 0.25 A	
1	P1	SIP header		
1	P2	SIP header		
1	Q1	STD8N80K5	800 V / 8 A	
1	R1	1 ohms	0.500 W	1%
1	R2	0.82 ohms	0.500 W	1%
1	R3	1 Kohms	0.125 W	1%
1	R4	10 Mohms	0.125 W	1%
1	R5	47 ohms	0.250 W	1%
1	R6	8.2 ohms	0.250 W	1%
1	R7, R8	47 Kohms	0.125 W	1%

Q.ty	Reference	Part / Value	Voltage / Watt / Ampere	Tolerance
1	R9	24 Kohms	0.125 W	1%
1	R10	100 Kohms	0.125 W	1%
1	R11	1 Kohms	0.600 W	1%
1	R12	470 ohms	0.250 W	1%
1	R13	N.M.		
1	R14	470 ohms	0.125 W	1%
1	T1	2294.0005	590 $\mu$ H/ 95k Hz/ 40 W	
1	U1	HVLED001A		
1	V1	ERZE07A431	MOV	

## 2 Mechanical drawing and connection

Figure 2: STEVAL-ILL076V2 – connections

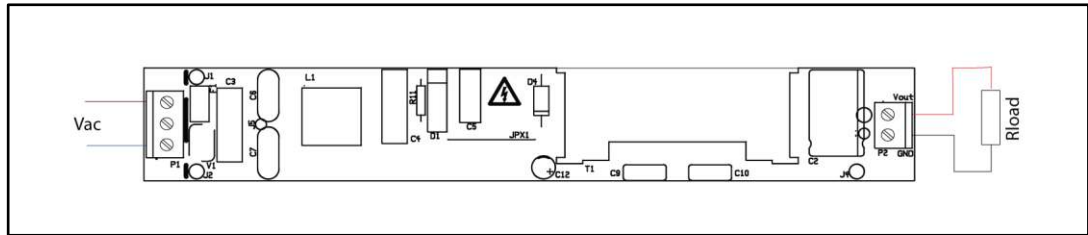

### 3 Revision history

Table 2: Document revision history

Date	Version	Changes
13-Sep-2016	1	Initial release.

**IMPORTANT NOTICE – PLEASE READ CAREFULLY**

STMicroelectronics NV and its subsidiaries ("ST") reserve the right to make changes, corrections, enhancements, modifications, and improvements to ST products and/or to this document at any time without notice. Purchasers should obtain the latest relevant information on ST products before placing orders. ST products are sold pursuant to ST's terms and conditions of sale in place at the time of order acknowledgement.

Purchasers are solely responsible for the choice, selection, and use of ST products and ST assumes no liability for application assistance or the design of Purchasers' products.

No license, express or implied, to any intellectual property right is granted by ST herein.

Resale of ST products with provisions different from the information set forth herein shall void any warranty granted by ST for such product.

ST and the ST logo are trademarks of ST. All other product or service names are the property of their respective owners.

Information in this document supersedes and replaces information previously supplied in any prior versions of this document.

© 2016 STMicroelectronics – All rights reserved